

# 966M/972M

## Wheel Loaders



### Engine

Engine Model	Cat® C9.3 ACERT™	
U.S. EPA Tier 4 Final/EU Stage IV		
966M – Maximum Gross Power – SAE J1995	232 kW	311 hp
972M – Maximum Gross Power – SAE J1995	251 kW	337 hp
U.S. EPA Tier 3/EU Stage IIIA equivalent		
966M – Maximum Gross Power – SAE J1995	230 kW	308 hp
972M – Maximum Gross Power – SAE J1995	246 kW	330 hp

### Weights

966M Operating Weight*	23 220 kg	51,176 lb
972M Operating Weight**	24 897 kg	54,871 lb

### Bucket Capacities

966M	2.5-9.2 m <sup>3</sup>	3.25-12.0 yd <sup>3</sup>
972M	2.9-9.9 m <sup>3</sup>	3.75-13.0 yd <sup>3</sup>

\*For 4.2 m<sup>3</sup> (5.5 yd<sup>3</sup>) general purpose buckets with BOCE.

\*\*For 4.8 m<sup>3</sup> (6.28 yd<sup>3</sup>) general purpose buckets with BOCE.

## RELIABLE, PRODUCTIVE AND FUEL EFFICIENT

- 10% more fuel efficient than the industry leading K Series\*
- Up to 25% more fuel efficient than H Series\*
- **Performance Series buckets** are easy to load and improve material retention
- **Cat Fusion™ coupler system and work tools** provide a wide range of work tools and allow the same work tool on different sizes of wheel loaders
- **Cat engine with ACERT Technology** meets Tier 3/Stage IIIA equivalent or Tier 4 Final/Stage IV emission standards and includes Cat Clean Emissions Module for continuous and efficient operation, if required
- **Advanced powershift transmission** with a standard lock up clutch torque converter and lock-to-lock shifting delivers smooth shifts, fast acceleration and speed on grade
- **Next generation axle** with standard on-the-go disc-type front manual differential locks to provide optimal traction in varying underfoot conditions for improved productivity
- **Next generation load-sensing hydraulic system** to provide optimal control of machine functions

## EASE OF OPERATION

- **Best-in-class operator environment** for unmatched operator comfort and efficiency
- **Advanced technology with Cat Connect** to monitor, manage and enhance job site operations

## SERVICE ACCESS

- **One-piece hood, centralized service centers, windshield cleaning platform and harness tie-off** to provide the best in class service access

## Contents

Reliable .....	4
Durable .....	5
Productive .....	6
Fuel Efficient .....	7
Easy to Operate .....	8
Versatile.....	10
Integrated Technologies.....	12
Owning Costs.....	14
Operating Costs.....	15
Serviceable .....	16
Sustainable .....	17
Customer Support.....	17
Specifications.....	18
Standard Equipment.....	34
Optional Equipment.....	35



*\*Fuel efficiency is measured in mass of material moved per volume of fuel burned. Average efficiency improvement as tested and analyzed for an average composite cycle and standard configuration with variations per comparable model with and without Economy Mode active. Factors influence result variation such as, but not limited to, machine configuration, operator technique, machine application, climate, etc.*



**The new 966M and 972M Wheel Loaders have a Tier 3/Stage IIIA equivalent or Tier 4 Final/Stage IV engine equipped with a combination of proven electronic, fuel, air and aftertreatment components, if required. Applying proven technologies systematically and strategically lets us meet our customer's high expectations for productivity and fuel efficiency. Deep system integration results in improved performance, improved fuel economy, and reduced emissions without interrupting machine performance making it seamless to operators. The reliability, durability, and versatility of both the 966M and 972M result in machines that are better built to meet your needs.**



# Reliable

Proven Components and Technology You Can Count On.

Every Tier 3/Stage IIIA equivalent or Tier 4 Final/Stage IV engine is equipped with a combination of proven electronic, fuel, air and aftertreatment components, if required.

## More Powerful, Reliable Engine Electronics

The electronics used in Cat Tier 3/Stage IIIA equivalent or Tier 4 Final/Stage IV engines are more powerful and robust than ever. Increased features and connection commonality improve the customer experience and increase quality and reliability. Over-foam wiring harness adds to reliability even in the most demanding applications.

## Hydraulics

The 966M and 972M hydraulic systems have significant design changes and customer value improvements. The main hydraulic valve is now a mono-block with an integrated ride control section. The mono-block design reduces weight, has forty percent fewer leak points and is common across all M Series models. Auxiliary third and fourth hydraulic functions can be easily added at the factory or in the field with the addition of a second remote valve.

## Equipment Monitoring

Cat Connect technologies and Cat dealer services take the guesswork out of equipment management. Product Link™ and the online VisionLink® application enable you to monitor real-time machine data and manage machines health. Your Cat dealer offers expert advice and S-O-S<sup>SM</sup> Services to maintain equipment reliability and efficiency.

## Cold Start Package

The new optional cold start package provides dependable starts in extreme cold weather and high altitudes.



## Durable

Better Designed to Meet Your Needs.

### Frames

The robotically welded two-piece structural frame design provides strong and rigid structures that absorb all the forces associated to penetration, loading and twisting.

The M Series articulating hitch system, joining the front and rear frames, provides increased bearing force capacity.

### Axles

The M Series axles are designed to handle extreme applications resulting in reliable performance and durable life. The rear axle can oscillate to  $\pm 13$  degrees helping to ensure all four wheels stay on the ground providing stability even in the roughest terrain, for excellent stability and traction.

# Productive

Work Smart and Move More.



The right technologies fine-tuned for the right applications result in:

- **Delivering Better Fuel Economy** with minimized maintenance costs while providing the same great power and response.
- **High Performance** across a variety of applications.
- **Enhanced Reliability** through commonality and simplicity of design.
- **Maximized Uptime and Reduced Cost** with world-class support from the Cat dealer network.
- **Durable Designs** with long life to overhaul.

## Hydraulics

The new ride control system now has two accumulators enabling it to be more effective over a greater payload range, increasing productivity and operator efficiency due to a better ride.

The next generation implement pump continuously and automatically balance hydraulic loads with the machine performance desired by the operator. Engine response is improved as is performance at higher altitudes.

## Transmission

The 966M and 972M power trains have been improved with the addition of a lock-up clutch torque converter standard. These new torque converters have been matched with the engine power and hydraulics to improve performance and fuel efficiency. These rugged planetary transmissions also have a new split-flow oil system which use new multi-viscosity oil to improve fuel economy.

## Axles

In addition to aggregates, sand and gravel and batch plants, these models are commonly used in heavy construction applications where poor underfoot conditions make traction difficult slowing production and challenging job deadlines. The new on-the-fly disc-type differential locks will improve tractive ability in these applications thereby increasing productivity. These models come standard with front axle differential locks which are manually activated by a switch on the floor. Optional fully automatic front and rear axle differential locks operate by measuring differences in axle speeds and require no operator intervention to activate. These disc-type differential locks will reduce tire scuffing compared to other traction aids further reducing operating costs for customers.

The axles have new external caliper disc parking brakes mounted to the input shaft of the front axles. Since they are external, they do not have the inefficiencies of enclosed wet parking brakes due to brake discs running in oil nor is there any oil to change reducing fuel and maintenance costs. External caliper parking brakes are easily accessible for inspection and service.

# Fuel Efficient Engineered to Lower Your Operating Costs.

## Engine and Emissions

The Cat C9.3 ACERT engine is designed for maximum fuel efficiency and increased power density, while meeting Tier 3/Stage IIIA equivalent or Tier 4 Final/Stage IV emission standards. This engine features innovative Cat electronics, a fuel injection process, air-management systems; an aftertreatment solution with Cat Selective Catalytic Reduction, and a fuel efficient regeneration system, if required. For Tier 4 Final/Stage IV emissions solutions, the Tier 4 Final C9.3 is a fully passive engine without the Cat Regeneration System.

## Efficient Systems and Components

Innovative systems intelligently lower the average working engine speeds and reduce the overall system heat loads which result in significantly improved performance and fuel efficiency.

## Advanced Systems with Innovative Integration

The deep system integration of the new engine and emissions system, power train, hydraulic system and cooling system result in lower fuel consumption on average as compared to previous generation machines.

## Productive Economy Mode

The productive economy mode automatically controls the engine torque and speed based on the machine's power train load and places engine speed and torque in the most efficient operating range. The result is improved fuel efficiency while delivering optimal performance.



## Tier 4 Final/Stage IV Engines

- **Next Generation Fuel Systems** – Cat injection timing precisely controls the fuel injection process through a series of carefully timed microbursts, providing more control of combustion for the cleanest, most efficient fuel burn. On the 966M and 972M, the High-Pressure Common Rail Fuel Systems boost performance and reduce soot for the C9.3 ACERT engine.
- **Cat NO<sub>x</sub> Reduction System** – The Cat NO<sub>x</sub> Reduction System (NRS) captures and cools a small quantity of exhaust gas, then routes it back into the combustion chamber where it drives down combustion temperatures and reduces NO<sub>x</sub> emissions.
- **Aftertreatment Technologies** – To meet the additional 80% reduction in NO<sub>x</sub> emissions required by Tier 4 Final/Stage IV emission standards, one new system, the Selective Catalytic Reduction (SCR), has been added to the already proven Cat Tier 4 Interim/Stage IIIB aftertreatment solution.

# Easy to Operate

Safe. Comfortable. Efficient.



Ensuring operators are safe, confident in the control of their machines, have a clean, comfortable and quiet operating environment with controls that are intuitive and low effort all contribute to lower operator fatigue and better performance.

## Cab Access

A switch has been added to the electronic service center which unlatches the door remotely (optional). The gas strut then swings the door open all while the operator is safely on the ground. The angle of the steps up to the cab have been increased to an optimal fifteen degrees enabling operators to walk up like stairs versus climbing more vertically like a ladder. Grab handles have been repositioned so a secure three points of contact can be maintained at all times.



## Visibility

Once in the cab, the new door securely seals against the new roll formed ROPS posts and the lower glass panel has been extended several inches to improve visibility to the left side of the machine. New larger convex mirrors improve visibility to the rear and integrated spot mirrors provide visibility close to both sides of the machine.

## Sound

Viscous cab mounts connect the cab to the frame of the machine, decreasing noise and vibration the operator is subjected to. The result is a sustainable work environment and well-rested operator, remaining efficient and productive.

## Central Display

The central display panel has a large text box, analog gauges, and LED warning indicators. The large text box provides in-language information about machine operation, feature activation and system troubleshooting and calibration. With the large analog gauges the operator can easily identify if key systems are within normal operating range.





## Touch Screen Display

A new multipurpose color touch screen display dramatically simplifies the operator interface; with machine controls, rear vision camera and new fully integrated Cat Production Measurement system. Intuitive navigation with in-language text enables operators to modify certain machine operating parameters and monitor machine conditions literally at the touch of their fingers.

## Control Panel

Sealed against moisture and dirt, the centralized switch panel with LEDs provides reliability and ready access to frequently required functions, even while wearing gloves. The ISO symbols located on each membrane switch are molded all the way through to ensure the image will not wear off over time.

The M Series maintains the “help” feature which explains the function of each membrane switch.

Focusing on operator efficiency, the control panel has been streamlined to include easy to reach highly utilized machine controls. The touch screen display enables the relocation of some expanded functions while eliminating the need for a second switch panel for further simplicity and easy machine operation.



## Electro-Hydraulic (EH) Joystick Steering with Force Feedback (Speed Sensitive)

Your operators will enjoy and quickly adopt the industry leading seat mounted EH joystick steering system, which provide precision control and dramatically decrease operator arm fatigue.

## Implement Controls (EH)

Seat mounted single axis implement control levers (joysticks, optional) provide your operator with precise control of the work tool, all while moving with the seat for maximum comfort. In-cab programmable kick-outs and automatic cylinder snubbing are easy to set on-the-go for tilt, lower and lift, ideal for repeatable cycles.



## Ride Control

The next generation of ride control works as a shock absorber, improving ride quality and smoothness over rough terrain, increasing your operator confidence, comfort and efficiency, ensuring excellent material retention.

# Versatile

Linkage and Guard Options to Meet Your Various Applications Needs.



## Standard Z-bar Linkage

The proven Z-bar linkage combines digging efficiency with excellent visibility to the tool resulting in excellent penetration into the pile, high breakout forces and superior production capabilities.

## High Lift Linkage

The optional high lift linkage offers increased hinge pin height to load more easily in a variety of applications with any type of bucket or fork.

## Aggregate Handler

Aggregate packages are specialized offerings for specific loose aggregate rehandling applications, such as truck loading, hopper charging, stockpiling, and load and carry. Rehandling loose aggregate is less stressful on the machine, therefore payloads can be increased above other applications by installing larger buckets, counterweights.

To do so, the Cat aggregate packages require conformance to Caterpillar payload policy. Misapplication of Aggregate Handlers may result in significant reliability and durability risk.

## Industrial and Waste Handler

The Industrial and Waste Packages offer integrated guards to preserve your machine from the harsh environment of a scrap or waste handling application.

## Forestry Arrangement

The 966M Forestry package includes a heavy duty linkage, a larger tilt cylinder and a heavier counterweight to safely handle the larger loads met in logging and millyard applications.

## Steel Mill Arrangement

The 972M Steel Mill package includes all the modifications required to allow the removal and handling of hot slag while providing additional protection for both machine and operator in these extreme applications.



# Versatile

## Do More Jobs with One Machine, Fusion Quick Coupler and Various Work Tools.

An extensive range of work tools and bucket styles are available to customize these machines for your operation. Work tools are available either with pin on or quick coupler interface.

### Performance Series Buckets

- **Load Easy, Fuel Efficient, Carry More** – Performance Series Buckets utilize a system-based approach to balance bucket shape with the machine’s linkage, weight, lift and tilt capacities. Operators benefit from reduced dig times and better material retention; ultimately translating into significant productivity and fuel efficiency improvements.
- **Lower Operating Costs** – Performance Series Buckets feature a longer floor that easily digs through the pile and provides excellent visibility for the operators to see when the bucket is full. Less time digging in the pile results in lower fuel consumption and improved tire life. A unique spill guard protects the cab and linkage components from material overflow.
- **Higher Productivity** – Performance Series Buckets achieve higher fill factors – ranging from 100% to 115% depending on the machine application and material type. The buckets feature a curved side profile to maximize material retention. The optimized design results in unsurpassed production capabilities.

## Fusion Quick Coupler

### Improved Machine Performance

Fusion is the patented wheel loader coupler system from Caterpillar. The Fusion Coupler System provides performance virtually identical to pin on – with all the flexibility of a quick coupler system. The Fusion Coupler sits back, close in to the loader arms – minimizing offset and increasing the machine’s performance.

### No Loss of Performance

Fusion is designed to integrate the work tool and the machine by pulling the coupler and tool closer in to the loader. As a result, the center of gravity is moved inward, towards the machine. This translates to increased lifting ability when compared to machines equipped with other coupler systems.

### Unsurpassed Durability

An advanced wedging mechanism creates a tight, rattle-free fit. This patented lock up system eliminates play and wear – resulting in a long service life.

### Increased Visibility

A new, open coupler frame design clears sight lines from the operator’s seat, making it easier than ever before to engage and disengage attachments with certainty.

### Common Interface Compatibility

The Fusion Coupler System not only allows one machine to use a range of work tools, but also allows one work tool to be picked up by machines of many different sizes.

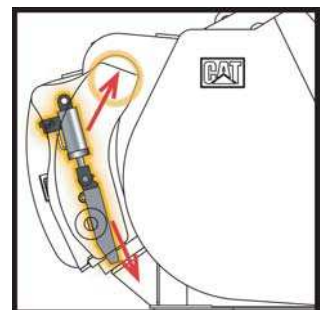
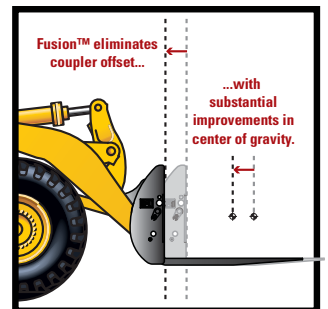



# Integrated Technologies

## Monitor, Manage, and Enhance Job Site Operations.

Cat Connect makes smart use of technology and services to improve your job site efficiency. Using the data from technology-equipped machines, you'll get more information and insight into your equipment and operations than ever before.

Cat Connect technologies offer improvements in these key areas:



EQUIPMENT  
MANAGEMENT

**Equipment Management** – increase uptime and reduce operating costs.



PRODUCTIVITY

**Productivity** – monitor production and manage job site efficiency.



SAFETY

**Safety** – enhance job site awareness to keep your people and equipment safe.

Featured Cat Connect technologies include:

### Cat Connect LINK Technologies

LINK technologies wirelessly connect you to your equipment giving you access to essential information you need to know to run your business. Link data can give you valuable insight into how your machine or fleet is performing so you can make timely, fact-based decisions that can boost job site efficiency and productivity.

### Product Link/VisionLink

Product Link is deeply integrated into your machine to take the guesswork out of equipment management. Easy access to timely information like machine location, hours, fuel usage, idle time and event codes via the online VisionLink user interface can help you effectively manage your fleet and lower operating cost.



## PAYLOAD Technologies

PAYLOAD technologies provide accurate weighing of materials being loaded and hauled. Payload data is displayed for loader operators in real-time to improve productivity, reduce overloading, and recorded to track material movement by shift.

- **Cat Production Measurement** – brings payload weighing to the cab, enabling operators to weigh loads “on-the-go” during loading operations. Loads are weighed as the bucket is raised during the lift cycle – eliminating the need to interrupt the load cycle, improving loading efficiency. Operators can view load weights on the integrated multi-function display and know precisely how much material is in the bucket and when trucks are filled to target payload – before leaving the loading zone. Instant feedback gives operators the confidence to work more effectively, maximizing the potential of the entire fleet. An optional in-cab printer provides the driver a printed receipt of truck payloads.

Operators can track recorded weights and cycles using the display. Site managers can wirelessly access data via the VisionLink web portal to measure production and monitor efficiency.

## DETECT Technologies

DETECT technologies enhance operator awareness of the environment around working equipment and provide alerts to help keep people and assets safe.

- **Rear Vision Camera** – enhances visibility behind the machine, helping the operator work confidently, at peak potential. A rear view and payload data is displayed on the multi-function monitor during reverse travel. An optional second display can be added to provide a dedicated rear view of the job site.

# Owning Costs

Proven Best Investment.



## Customer Support Agreements

A Customer Support Agreement (CSA) is an arrangement between you and your Cat dealer that helps you lower your total cost per ton. CSAs are flexible, allowing them to be tailored to your business needs. They can range from simple Preventive Maintenance Kits to elaborate Total Cost Performance Guarantees. Having a CSA with your Cat dealer enables more time for you to do what you do best – run your business.

## Monitoring Systems

Monitoring product health is key to optimizing the life of an investment into a Cat Wheel Loader.

- **Cat Product Link** – Cat Product Link allows remote monitoring of equipment to improve overall fleet management effectiveness. Product Link is deeply integrated into machine systems. Events and diagnostic codes, as well as hours, fuel, idle time and other detailed information are transmitted to a secure web based application, VisionLink. VisionLink includes powerful tools to convey information to users and dealers, including mapping, working and idle time, fuel level and more.
- **S-O-S Services** – Helps manage component life and decrease machine downtime, increasing productivity and efficiency. Regular fluid sampling can help track what is going on inside your machine. Wear related problems are predictable and easily repairable. Maintenance can be done to accommodate your schedule, resulting in increased uptime and flexibility in maintenance repairs before failure.

## Parts Availability

Caterpillar provides an unsurpassed level of personalized service to help you work more cost effectively and efficiently. By utilizing a worldwide parts network Cat dealers help minimize machine downtime and save money by delivering replacement parts within 24 hours.

## Resale Value

Owning quality equipment is an important factor in maintaining resale value. Caterpillar is not only known for machines that are better built, but provides product and dealer support to maintain the reliability and durability of your machine.



## Operating Costs

Save Time and Money by Working Smart.

Customer machine data shows Cat wheel loaders are the most fuel efficient machines in the industry with several features contributing to this excellent fuel efficiency:

- **Deep system integration between engine, hydraulics, transmission and ride control** results in reduced emissions, more productivity, and lower fuel consumption without interrupting machine performance.
- **Manual/automatic differential locks** increase traction and reduce tire scuffing lowering operating costs.
- **Productive economy mode** optimizes engine torque and speed further reducing fuel consumption.
- **Adjustable automatic idle engine shutdown system** significantly reduces idle time, overall operating hours and fuel consumption.
- **External caliper disc parking brakes** make maintenance easily accessible.

- **Lock-up clutch torque converter and shift strategy** increases driveline efficiency with reduced torque interruption conserving fuel. Auto 1-D transmission mode keeps engine speed low reducing fuel consumption while delivering optimal machine performance.
- **Performance Series buckets** deliver faster fill times and better material retention, ultimately reducing cycle times while improving productivity and fuel efficiency.

**Machine configuration, operator technique and job site layout can impact fuel consumption by as much as 30 percent.** Select the correct linkage, guarding, work tool and tire type based on machine application.

### Enabling Application Efficiency

- **Loading Bucket** – Load in first gear and keep engine rpm low. Raise and tilt bucket smoother, with Caterpillar’s multi-function capability, and do not use a “pumping” motion. Avoid lift lever detent and use of transmission neutralizer. Use programmable kick-outs and automatic cylinder snubbing during repeated cycles.
- **Loading Truck or Hopper** – Do not raise the work tool any higher than necessary. Keep engine rpm low and unload in controlled manner.
- **Idle** – Set the parking brake to engage Engine Idle Management System to conserve fuel.
- **Job Site Layout** – Spot loading targets in the right position. Avoid traveling more than twice the machine length during short cycle loading. Reduce transport distance for load and carry cycles by optimizing job site layout.

# Serviceable

Easy to Maintain. Easy to Service.

## Engine Access

The Cat sloped “one-piece” tilting hood provides industry leading access to the engine. Its design has further been improved on all M Series wheel loaders to provide the best-in-class service access to engine, oil levels and coolant sight gauge.

## Cooling System

The cooling system is readily accessible for clean out and maintenance. With nine cooling fins per 25.4 mm (1.0 in) and a perforated grill, most airborne debris entering the system passes through the cooler cores. The hydraulic and A/C cooler cores swing out providing easy access to both sides for cleaning. An access panel on the left side of the cooling package swings down to provide access to the back side of the engine coolant and Air-to-Air After Cooler (ATAAC). An optional variable pitch fan can automatically purge the cooler cores by periodically reversing the airflow when needed.

## Service Centers

The electrical and hydraulic service centers provide grouped ground level access to numerous features, enhancing safety and convenience for your operators and service technicians, while reducing service time.

The electrical service center, located beneath the left platform, contains the maintenance free batteries, a fuse relay panel, main disconnect switch, ground level engine shutdown switch, hood tilt switch, and the jump start receptacle.

Hydraulic system components on the 966M and 972M are protected by full flow and kidney-loop filtration. A filter in the hydraulic tank return line filters all of the oil returning to the tank. There is also a case drain screen for additional protection and finally, a separate kidney-loop filter with a finer micron rating continuously filters smaller particles out of the system. This multilevel design ensures the hydraulic oil is clean and thoroughly protects the rest of the hydraulic system from contamination. A new thermal bypass valve has been added to improve hydraulic system warm-up.

The hydraulic service centers are now virtually identical for the M Series product line. This new consistent layout makes it easier for service technicians who work on a variety of M Series models.





# Sustainable Conserving Resources.

The 966M and 972M are designed to compliment your business plan, reduce emissions and minimize the consumption of natural resources.

- Improved fuel efficiency – less fuel consumed results in lower emissions.
- Improved operator efficiency through enhanced visibility and reduced noise levels.
- Link technologies enable you to collect and analyze equipment and job site data so you can maximize productivity and reduce costs.
- Major components are rebuildable, eliminating waste and saving money by giving the machine and/or major components a second life – and even a third life.



## Customer Support Unmatched Support Makes the Difference.



### Renowned Cat Dealer Support

- Your Cat dealer is ready to help you every step of the way. From new or used machine sales, to rental or rebuild options, your Cat dealer can provide an optimal solution to your business needs.
- Unsurpassed worldwide parts availability, trained technicians and customer support agreements maximize your machine uptime.
- Financing options are offered to meet a variety of customer needs.

# 966M/972M Wheel Loaders Specifications

## Engine – 966M (Tier 3/Stage IIIA equivalent)

Engine Model	Cat C9.3 ACERT	
Maximum Gross Power (1,800 rpm)		
SAE J1995	230 kW	308 hp
Maximum Net Power (1,700 rpm)		
SAE J1349	207 kW	278 hp
Peak Gross Torque (1,200 rpm)		
SAE J1995	1600 N·m	1,180 lbf-ft
Maximum Net Torque (1,000 rpm)		
SAE J1349	1507 N·m	1,112 lbf-ft
Bore	115 mm	4.53 in
Stroke	149 mm	5.87 in
Displacement	9.3 L	568 in <sup>3</sup>

- Cat engine with ACERT Technology – meets Tier 3/Stage IIIA equivalent emission standards.

## Engine – 966M (Tier 4 Final/Stage IV)

Engine Model	Cat C9.3 ACERT	
Maximum Gross Power (1,800 rpm)		
SAE J1995	232 kW	311 hp
Maximum Net Power (1,700 rpm)		
SAE J1349	206 kW	276 hp
Peak Gross Torque (1,200 rpm)		
SAE J1995	1599 N·m	1,179 lbf-ft
Maximum Net Torque (1,000 rpm)		
SAE J1349	1527 N·m	1,126 lbf-ft
Bore	115 mm	4.53 in
Stroke	149 mm	5.87 in
Displacement	9.3 L	568 in <sup>3</sup>

- Cat engine with ACERT Technology meets Tier 4 Final/Stage IV emission standards.
- The power ratings apply at the stated speed when tested under the reference conditions for the specified standards.
- The net power advertised is the power available at the flywheel when the engine is equipped with fan, alternator, air cleaner and aftertreatment.
- The gross power advertised is with the fan at maximum speed.

## Engine – 972M (Tier 3/Stage IIIA equivalent)

Engine Model	Cat C9.3 ACERT	
Maximum Gross Power (1,800 rpm)		
SAE J1995	246 kW	330 hp
Maximum Net Power (1,700 rpm)		
SAE J1349	222 kW	298 hp
Peak Gross Torque (1,200 rpm)		
SAE J1995	1728 N·m	1,275 lbf-ft
Maximum Net Torque (1,000 rpm)		
SAE J1349	1632 N·m	1,204 lbf-ft
Bore	115 mm	4.53 in
Stroke	149 mm	5.87 in
Displacement	9.3 L	568 in <sup>3</sup>

- Cat engine with ACERT Technology – meets Tier 3/Stage IIIA equivalent emission standards.

## Engine – 972M (Tier 4 Final/Stage IV)

Engine Model	Cat C9.3 ACERT	
Maximum Gross Power (1,800 rpm)		
SAE J1995	251 kW	337 hp
Maximum Net Power (1,700 rpm)		
SAE J1349	223 kW	299 hp
Peak Gross Torque (1,200 rpm)		
SAE J1995	1728 N·m	1,275 lbf-ft
Maximum Net Torque (1,100 rpm)		
SAE J1349	1654 N·m	1,220 lbf-ft
Bore	115 mm	4.53 in
Stroke	149 mm	5.87 in
Displacement	9.3 L	568 in <sup>3</sup>

- Cat engine with ACERT Technology meets Tier 4 Final/Stage IV emission standards.
- The power ratings apply at the stated speed when tested under the reference conditions for the specified standards.
- The net power advertised is the power available at the flywheel when the engine is equipped with fan, alternator, air cleaner and aftertreatment.
- The gross power advertised is with the fan at maximum speed.

# 966M/972M Wheel Loaders Specifications

## Buckets – 966M

Bucket Capacities	2.5-9.2 m <sup>3</sup>	3.25-12.0 yd <sup>3</sup>
-------------------	------------------------	---------------------------

## Weight – 966M

Operating Weight	23 220 kg	51,176 lb
------------------	-----------	-----------

- Weight based on a machine configuration with Michelin 26.5R25 XHA2 L3 radial tires, full fluids, operator, standard counterweight, cold start, roading fenders, Product Link, manual diff lock/open axles (front/rear), power train guard, secondary steering, sound suppression and a 4.2 m<sup>3</sup> (5.5 yd<sup>3</sup>) general purpose bucket with BOCE.

## Operating Specifications – 966M

### Static Tipping Load – Full 37° Turn

With Tire Deflection	14 668 kg	32,329 lb
No Tire Deflection	15 822 kg	34,873 lb

Breakout Force	173 kN	38,984 lbf
----------------	--------	------------

- For a machine configuration as defined under “Weight.”
- Full compliance to ISO 143971:2007 Sections 1 thru 6, which requires 2% verification between calculations and testing.

## Transmission – 966M

Forward 1	6.5 km/h	4.0 mph
Forward 2	13.0 km/h	8.1 mph
Forward 3	23.5 km/h	14.6 mph
Forward 4	39.5 km/h	24.5 mph
Reverse 1	7.1 km/h	4.4 mph
Reverse 2	14.4 km/h	8.9 mph
Reverse 3	25.9 km/h	16.1 mph
Reverse 4	39.5 km/h	24.5 mph

- Maximum travel speed in standard vehicle with empty bucket and standard L3 tires with 826 mm (32.5 in) roll radius.

## Buckets – 972M

Bucket Capacities	2.9-9.9 m <sup>3</sup>	3.75-13.0 yd <sup>3</sup>
-------------------	------------------------	---------------------------

## Weight – 972M

Operating Weight	24 897 kg	54,871 lb
------------------	-----------	-----------

- Weight based on a machine configuration with Michelin 26.5R25 XHA2 L3 radial tires, full fluids, operator, standard counterweight, cold start, roading fenders, Product Link, manual diff lock/open axles (front/rear), power train guard, secondary steering, sound suppression and a 4.8 m<sup>3</sup> (6.28 yd<sup>3</sup>) general purpose bucket with BOCE.

## Operating Specifications – 972M

### Static Tipping Load – Full 37° Turn

With Tire Deflection	16 164 kg	35,626 lb
No Tire Deflection	17 421 kg	38,396 lb

Breakout Force	196 kN	44,075 lbf
----------------	--------	------------

- For a machine configuration as defined under “Weight.”
- Full compliance to ISO 143971:2007 Sections 1 thru 6, which requires 2% verification between calculations and testing.

## Transmission – 972M

Forward 1	6.7 km/h	4.2 mph
Forward 2	13.1 km/h	8.1 mph
Forward 3	23.2 km/h	14.4 mph
Forward 4	39.5 km/h	24.5 mph
Reverse 1	7.6 km/h	4.7 mph
Reverse 2	15.0 km/h	9.3 mph
Reverse 3	26.5 km/h	16.5 mph
Reverse 4	39.5 km/h	24.5 mph

- Maximum travel speed in standard vehicle with empty bucket and standard L3 tires with 826 mm (32.5 in) roll radius.

# 966M/972M Wheel Loaders Specifications

## Brakes

Brakes	Brakes meet ISO 3450 standards	
--------	--------------------------------	--

## Hydraulic System

Implement Pump Type	Variable Displacement Piston	
Implement System		
Maximum Pump Output (2,200 rpm)	360 L/min	95 gal/min
Maximum Operating Pressure	31 000 kPa	4,496 psi
Optional 3 <sup>rd</sup> /4 <sup>th</sup> Function Maximum Flow	240 L/min	63 gal/min
Optional 3 <sup>rd</sup> /4 <sup>th</sup> Function Maximum Pressure	21 780 kPa	3,159 psi
Hydraulic Cycle Time with Rated Payload	<b>966M</b>	<b>972M</b>
Raise from Carry Position	6.1 Sec.	6.1 Sec.
Dump, at Maximum Raise	1.4 Sec.	1.5 Sec.
Lower, Empty, Float Down	2.6 Sec.	3.1 Sec.
Total	10.1 Sec.	10.7 Sec.

## Axles

Front	Fixed	
Rear	Oscillating ±13 degrees	
Maximum Single-Wheel Rise and Fall	502 mm	19.5 in

## Cab

ROPS/FOPS	ROPS/FOPS meet ISO 3471 and ISO 3449 Level II standards	
-----------	---------------------------------------------------------	--

## Sound

- The sound values indicated below are for specific operating conditions only. Machine and operator sound levels will vary at different engine and/or cooling fan speeds. Hearing protection may be needed when the machine is operated with a cabin that is not properly maintained, or when the doors and/or windows are open for extended periods or in a noisy environment.

With Cooling Fan Speed at Maximum Value:

Operator Sound Pressure Level (ISO 6396:2008)	70 dB(A)
Exterior Sound Power Level (ISO 6395:2008)	109 dB(A)
Exterior Sound Pressure Level (SAE J88:2013)	76 dB(A)*

\*Distance of 15 m (49.2 ft), moving forward in second gear ratio.

## Service Refill Capacities

Fuel Tank	313 L	82.7 gal
DEF Tank*	16.8 L	4.4 gal
Cooling System	71.6 L	18.9 gal
Crankcase	24.5 L	6.5 gal
Transmission	58.5 L	15.5 gal
Differentials and Final Drives – Front	57 L	15.1 gal
Differentials and Final Drives – Rear	57 L	15.1 gal
Hydraulic Tank	125 L	33 gal

\*Must meet the requirements outlined in ISO 22241-1 for Tier 4 Final/Stage IV models.

# 966M/972M Wheel Loaders Specifications

## 966M Dimensions

All dimensions are approximate.

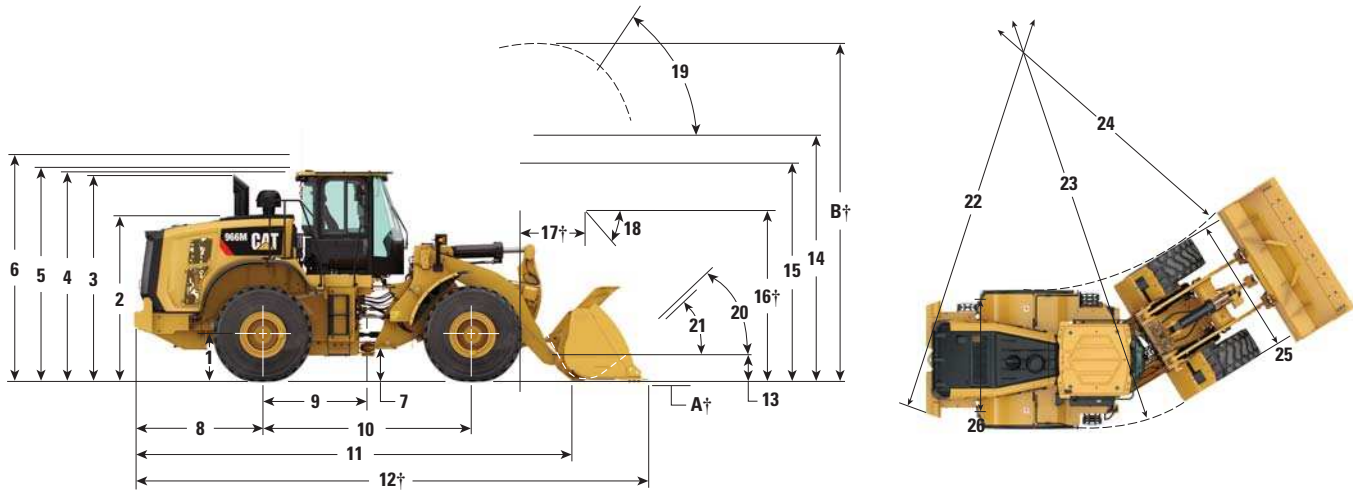

	Standard Lift		High Lift	
1 Height to Axle Centerline	799 mm	2'7"	799 mm	2'7"
2 Height to Top of Hood	2818 mm	9'3"	2818 mm	9'3"
3 Height to Top of Exhaust Pipe	3522 mm	11'7"	3522 mm	11'7"
4 Height to Top of ROPS	3587 mm	11'9"	3587 mm	11'9"
5 Height to Top of Product Link Antenna	3636 mm	11'11"	3636 mm	11'11"
6 Height to Top of Warning Beacon	3859 mm	12'8"	3859 mm	12'8"
7 Ground Clearance	434 mm	1'5"	434 mm	1'5"
8 Center Line of Rear Axle to Edge of Counterweight	2180 mm	7'2"	2500 mm	8'2"
9 Center Line of Rear Axle to Hitch	1775 mm	5'10"	1775 mm	5'10"
10 Wheelbase	3550 mm	11'8"	3550 mm	11'8"
11 Overall Length (without bucket)	7289 mm	23'11"	8109 mm	26'8"
12 Shipping Length (with bucket level on ground)*†	8750 mm	28'9"	9570 mm	31'5"
13 Hinge Pin Height at Carry Height	630 mm	2'1"	778 mm	2'7"
14 Hinge Pin Height at Maximum Lift	4235 mm	13'11"	4793 mm	15'9"
15 Lift Arm Clearance at Maximum Lift	3643 mm	11'11"	4140 mm	13'6"
16 Dump Clearance at Maximum Lift and 45° Discharge*†	2991 mm	9'9"	3549 mm	11'7"
17 Reach at Maximum Lift and 45° Discharge*†	1353 mm	4'5"	1328 mm	4'4"
18 Dump Angle at Maximum Lift and Dump (on stops)*	49 degrees		48 degrees	
19 Rack Back at Maximum Lift*	62 degrees		71 degrees	
20 Rack Back at Carry Height*	50 degrees		49 degrees	
21 Rack Back at Ground*	42 degrees		39 degrees	
22 Clearance Circle (diameter) to Counterweight	13 608 mm	44'8"	13 608 mm	44'8"
23 Clearance Circle (diameter) to Outside of Tires	13 522 mm	44'5"	13 522 mm	44'5"
24 Clearance Circle (diameter) to Inside of Tires	7706 mm	25'4"	7706 mm	25'4"
25 Width over Tires (unloaded)	2991 mm	9'10"	2991 mm	9'10"
26 Tread Width	2230 mm	7'4"	2230 mm	7'4"

\*With 4.2 m<sup>3</sup> (5.5 yd<sup>3</sup>) general purpose pin on bucket with BOCE (see Operating Specifications for other buckets).

†Dimensions are listed in Operating Specification charts.

All height and tire related dimensions are with Michelin 26.5R25 XHA2 L3 tires (see Tire Option Chart for other tires).

# 966M/972M Wheel Loaders Specifications

## 972M Dimensions

All dimensions are approximate.

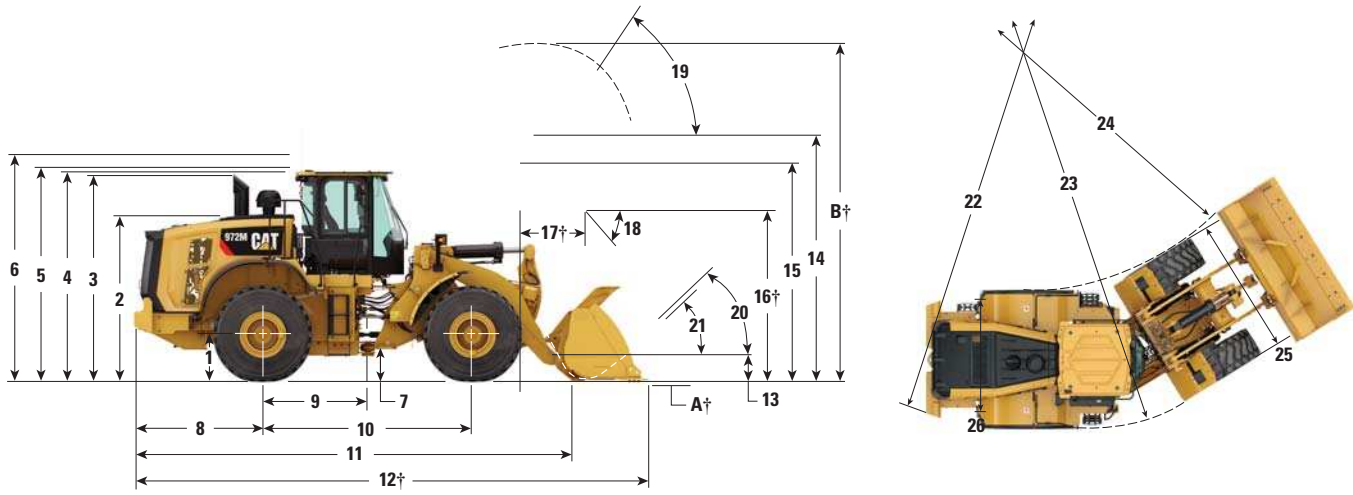

	Standard Lift		High Lift		Extended Capacity	
1 Height to Axle Centerline	799 mm	2'7"	2818 mm	9'3"	799 mm	2'7"
2 Height to Top of Hood	2818 mm	9'3"	2818 mm	9'3"	2818 mm	9'3"
3 Height to Top of Exhaust Pipe	3522 mm	11'7"	3522 mm	11'7"	3522 mm	11'7"
4 Height to Top of ROPS	3587 mm	11'9"	3587 mm	11'9"	3587 mm	11'9"
5 Height to Top of Product Link Antenna	3636 mm	11'11"	3636 mm	11'11"	3636 mm	11'11"
6 Height to Top of Warning Beacon	3859 mm	12'8"	3859 mm	12'8"	3859 mm	12'8"
7 Ground Clearance	434 mm	1'5"	434 mm	1'5"	434 mm	1'5"
8 Center Line of Rear Axle to Edge of Counterweight	2500 mm	8'2"	2500 mm	8'2"	2500 mm	8'2"
9 Center Line of Rear Axle to Hitch	1775 mm	5'10"	1775 mm	5'10"	1775 mm	5'10"
10 Wheelbase	3550 mm	11'8"	3550 mm	11'8"	3550 mm	11'8"
11 Overall Length (without bucket)	7774 mm	25'7"	8109 mm	26'8"	7609 mm	25'0"
12 Shipping Length (with bucket level on ground)*†	9315 mm	30'7"	9650 mm	31'8"	9164 mm	30'1"
13 Hinge Pin Height at Carry Height	680 mm	2'3"	778 mm	2'7"	631 mm	2'1"
14 Hinge Pin Height at Maximum Lift	4458 mm	14'8"	4793 mm	15'9"	4235 mm	13'11"
15 Lift Arm Clearance at Maximum Lift	3843 mm	12'7"	4140 mm	13'6"	3643 mm	11'11"
16 Dump Clearance at Maximum Lift and 45° Discharge*†	3154 mm	10'4"	3490 mm	11'5"	2920 mm	9'6"
17 Reach at Maximum Lift and 45° Discharge*†	1357 mm	4'5"	1380 mm	4'6"	1413 mm	4'7"
18 Dump Angle at Maximum Lift and Dump (on stops)*	48 degrees		48 degrees		48 degrees	
19 Rack Back at Maximum Lift*	56 degrees		71 degrees		62 degrees	
20 Rack Back at Carry Height*	50 degrees		49 degrees		50 degrees	
21 Rack Back at Ground*	41 degrees		39 degrees		42 degrees	
22 Clearance Circle (diameter) to Counterweight	13 608 mm	44'8"	13 608 mm	44'8"	13 608 mm	44'8"
23 Clearance Circle (diameter) to Outside of Tires	13 522 mm	44'5"	13 522 mm	44'5"	13 522 mm	44'5"
24 Clearance Circle (diameter) to Inside of Tires	7706 mm	25'4"	7706 mm	25'4"	7706 mm	25'4"
25 Width over Tires (unloaded)	2991 mm	9'10"	2991 mm	9'10"	2991 mm	9'10"
26 Tread Width	2230 mm	7'4"	2230 mm	7'4"	2230 mm	7'4"

\*Standard and High Lift are with 4.8 m<sup>3</sup> (6.3 yd<sup>3</sup>) general purpose pin on bucket with BOCE (see Operating Specifications for other buckets).  
 Extended Capacity is with a 4.9 m<sup>3</sup> (6.4 yd<sup>3</sup>) general purpose pin on bucket with BOCE (see Operating Specifications for other buckets).

†Dimensions are listed in Operating Specification charts.

All height and tire related dimensions are with Michelin 26.5R25 XHA2 L3 tires (see Tire Option Chart for other tires).

# 966M/972M Wheel Loaders Specifications

## Dimension Changes – Tires

Tire Brand	Michelin	Michelin	Michelin	Bridgestone	Bridgestone	Bridgestone
<b>Tire Size</b>	<b>26.5R25</b>	<b>26.5R25</b>	<b>26.5R25</b>	<b>26.5R25</b>	<b>26.5R25</b>	<b>775/65R29</b>
<b>Tread Type</b>	<b>L-4</b>	<b>L-5</b>	<b>L-5</b>	<b>L-3</b>	<b>L-5</b>	<b>L-3</b>
<b>Tread Pattern</b>	<b>XLDD1</b>	<b>XLDD2</b>	<b>XMINED2</b>	<b>VJT</b>	<b>VSDL</b>	<b>VTS</b>
Width over Tires – Maximum (empty)*	2987 mm 9'10"	2986 mm 9'10"	2970 mm 9'9"	2982 mm 9'9"	2874 mm 9'5"	3080 mm 10'1"
Width over Tires – Maximum (loaded)*	3019 mm 9'11"	3011 mm 9'11"	2994 mm 9'10"	3016 mm 9'11"	2900 mm 9'6"	3101 mm 10'2"
Change in Vertical Dimensions (average of front and rear)	44 mm 1.7"	39 mm 1.5"	53 mm 2.1"	15 mm 0.6"	50 mm 2"	17 mm 0.7"
Change in Horizontal Reach	-36 mm -1.4"	-34 mm -1.3"	-32 mm -1.3"	-3 mm -0.1"	-29 mm -1.1"	-5 mm -0.2"
Change in Clearance Circle (radius) to Outside of Tires	5 mm 0.2"	1 mm 0"	-7 mm -0.3"	3 mm 0.1"	-54 mm -2.1"	46 mm 1.8"
Change in Clearance Circle (radius) to Inside of Tires	-5 mm -0.2"	-1 mm 0"	7 mm 0.3"	-3 mm -0.1"	54 mm 2.1"	-46 mm -1.8"
Change in Operating Weight (without Ballast)	420 kg 926 lb	716 kg 1,578 lb	1068 kg 2,354 lb	164 kg 361 lb	1136 kg 2,504 lb	856 kg 1,886 lb

\*Width over bulge and includes tire growth.

## Changes Specific to the 966M

Tire Brand	Michelin	Michelin	Michelin	Bridgestone	Bridgestone	Bridgestone
<b>Tire Size</b>	<b>26.5R25</b>	<b>26.5R25</b>	<b>26.5R25</b>	<b>26.5R25</b>	<b>26.5R25</b>	<b>775/65R29</b>
<b>Tread Type</b>	<b>L-4</b>	<b>L-5</b>	<b>L-5</b>	<b>L-3</b>	<b>L-5</b>	<b>L-3</b>
<b>Tread Pattern</b>	<b>XLDD1</b>	<b>XLDD2</b>	<b>XMINED2</b>	<b>VJT</b>	<b>VSDL</b>	<b>VTS</b>
Change in Static Tipping Load – Straight	303 kg 669 lb	517 kg 1,140 lb	771 kg 1,700 lb	118 kg 261 lb	821 kg 1,809 lb	618 kg 1,362 lb
Change in Static Tipping Load – Articulated	271 kg 596 lb	461 kg 1,017 lb	688 kg 1,516 lb	106 kg 233 lb	732 kg 1,613 lb	551 kg 1,215 lb

## Changes Specific to the 972M

Tire Brand	Michelin	Michelin	Michelin	Bridgestone	Bridgestone	Bridgestone
<b>Tire Size</b>	<b>26.5R25</b>	<b>26.5R25</b>	<b>26.5R25</b>	<b>26.5R25</b>	<b>26.5R25</b>	<b>775/65R29</b>
<b>Tread Type</b>	<b>L-4</b>	<b>L-5</b>	<b>L-5</b>	<b>L-3</b>	<b>L-5</b>	<b>L-3</b>
<b>Tread Pattern</b>	<b>XLDD1</b>	<b>XLDD2</b>	<b>XMINED2</b>	<b>VJT</b>	<b>VSDL</b>	<b>VTS</b>
Change in Static Tipping Load – Straight	283 kg 623 lb	482 kg 1,062 lb	719 kg 1,584 lb	110 kg 243 lb	764 kg 1,685 lb	576 kg 1,269 lb
Change in Static Tipping Load – Articulated	252 kg 555 lb	429 kg 946 lb	640 kg 1,411 lb	98 kg 216 lb	680 kg 1,499 lb	513 kg 1,131 lb

# 966M/972M Wheel Loaders Specifications

## 966M Bucket Fill Factors and Selection Chart

The bucket size must be chosen based on the density of the material and on the expected fill factor. The new Cat Performance Series Buckets with longer floor, larger bucket opening, increased repository angle, rounded side boards and integrated spill guard, demonstrate fill factors significantly higher than previous generation or non Cat buckets. The actual volume handled by the machine is thus often larger than the rated capacity.

Loose Material		Material Density	Fill Factor (%)*
Earth/Clay		1500-1700 kg/m <sup>3</sup> (2,528-2,865 lb/yd <sup>3</sup> )	115
Sand and Gravel		1500-1700 kg/m <sup>3</sup> (2,528-2,865 lb/yd <sup>3</sup> )	115
Aggregate:	25-76 mm (1 to 3 in)	1600-1700 kg/m <sup>3</sup> (2,696-2,865 lb/yd <sup>3</sup> )	110
	19 mm (0.75 in) and smaller	1800 kg/m <sup>3</sup> (3,033 lb/yd <sup>3</sup> )	105
Rock:	76 mm (3 in) and larger	1600 kg/m <sup>3</sup> (2,696 lb/yd <sup>3</sup> )	100

\*As a % of ISO rated capacity.

**Note:** Fill Factors achieved will also depend on whether the product is washed or not washed.

Material Density	kg/m <sup>3</sup>	700 800 900 1000 1100 1200 1300 1400 1500 1600 1700 1800 1900 2000 2100 2200 2300 2400 2500																							
Standard Linkage	Pin On	General Purpose	3.80 m <sup>3</sup> (5.00 yd <sup>3</sup> )															4.37 m <sup>3</sup> (5.72 yd <sup>3</sup> )				3.80 m <sup>3</sup> (5.00 yd <sup>3</sup> )			
			4.00 m <sup>3</sup> (5.25 yd <sup>3</sup> )															4.60 m <sup>3</sup> (6.02 yd <sup>3</sup> )				4.00 m <sup>3</sup> (5.25 yd <sup>3</sup> )			
			4.20 m <sup>3</sup> (5.50 yd <sup>3</sup> )															4.83 m <sup>3</sup> (6.32 yd <sup>3</sup> )				4.20 m <sup>3</sup> (5.50 yd <sup>3</sup> )			
Standard Linkage	Fusion QC	General Purpose	3.80 m <sup>3</sup> (5.00 yd <sup>3</sup> )															4.37 m <sup>3</sup> (5.72 yd <sup>3</sup> )				3.80 m <sup>3</sup> (5.00 yd <sup>3</sup> )			
			4.20 m <sup>3</sup> (5.50 yd <sup>3</sup> )															4.83 m <sup>3</sup> (6.32 yd <sup>3</sup> )				4.20 m <sup>3</sup> (5.50 yd <sup>3</sup> )			
			4.20 m <sup>3</sup> (5.50 yd <sup>3</sup> )															4.83 m <sup>3</sup> (6.32 yd <sup>3</sup> )				4.20 m <sup>3</sup> (5.50 yd <sup>3</sup> )			
Standard Linkage	Pin On	Material Handling	4.20 m <sup>3</sup> (5.50 yd <sup>3</sup> )															4.83 m <sup>3</sup> (6.32 yd <sup>3</sup> )				4.20 m <sup>3</sup> (5.50 yd <sup>3</sup> )			
			3.80 m <sup>3</sup> (5.00 yd <sup>3</sup> )															4.37 m <sup>3</sup> (5.72 yd <sup>3</sup> )				3.80 m <sup>3</sup> (5.00 yd <sup>3</sup> )			
			4.00 m <sup>3</sup> (5.25 yd <sup>3</sup> )															4.60 m <sup>3</sup> (6.02 yd <sup>3</sup> )				4.00 m <sup>3</sup> (5.25 yd <sup>3</sup> )			
High Lift Linkage	Pin On	General Purpose	3.80 m <sup>3</sup> (5.00 yd <sup>3</sup> )															4.37 m <sup>3</sup> (5.72 yd <sup>3</sup> )				3.80 m <sup>3</sup> (5.00 yd <sup>3</sup> )			
			4.00 m <sup>3</sup> (5.25 yd <sup>3</sup> )															4.60 m <sup>3</sup> (6.02 yd <sup>3</sup> )				4.00 m <sup>3</sup> (5.25 yd <sup>3</sup> )			
			4.20 m <sup>3</sup> (5.50 yd <sup>3</sup> )															4.83 m <sup>3</sup> (6.32 yd <sup>3</sup> )				4.20 m <sup>3</sup> (5.50 yd <sup>3</sup> )			
High Lift Linkage	Fusion QC	General Purpose	3.80 m <sup>3</sup> (5.00 yd <sup>3</sup> )															4.37 m <sup>3</sup> (5.72 yd <sup>3</sup> )				3.80 m <sup>3</sup> (5.00 yd <sup>3</sup> )			
			4.20 m <sup>3</sup> (5.50 yd <sup>3</sup> )															4.83 m <sup>3</sup> (6.32 yd <sup>3</sup> )				4.20 m <sup>3</sup> (5.50 yd <sup>3</sup> )			
			4.20 m <sup>3</sup> (5.50 yd <sup>3</sup> )															4.83 m <sup>3</sup> (6.32 yd <sup>3</sup> )				4.20 m <sup>3</sup> (5.50 yd <sup>3</sup> )			
High Lift Linkage	Pin On	Material Handling	4.20 m <sup>3</sup> (5.50 yd <sup>3</sup> )															4.83 m <sup>3</sup> (6.32 yd <sup>3</sup> )				4.20 m <sup>3</sup> (5.50 yd <sup>3</sup> )			
			3.80 m <sup>3</sup> (5.00 yd <sup>3</sup> )															4.37 m <sup>3</sup> (5.72 yd <sup>3</sup> )				3.80 m <sup>3</sup> (5.00 yd <sup>3</sup> )			
			4.00 m <sup>3</sup> (5.25 yd <sup>3</sup> )															4.60 m <sup>3</sup> (6.02 yd <sup>3</sup> )				4.00 m <sup>3</sup> (5.25 yd <sup>3</sup> )			
Aggregate Handler Package	Pin On	General Purpose	3.80 m <sup>3</sup> (5.00 yd <sup>3</sup> )															4.37 m <sup>3</sup> (5.72 yd <sup>3</sup> )				3.80 m <sup>3</sup> (5.00 yd <sup>3</sup> )			
			4.00 m <sup>3</sup> (5.25 yd <sup>3</sup> )															4.60 m <sup>3</sup> (6.02 yd <sup>3</sup> )				4.00 m <sup>3</sup> (5.25 yd <sup>3</sup> )			
			4.20 m <sup>3</sup> (5.50 yd <sup>3</sup> )															4.83 m <sup>3</sup> (6.32 yd <sup>3</sup> )				4.20 m <sup>3</sup> (5.50 yd <sup>3</sup> )			
Aggregate Handler Package	Fusion QC	General Purpose	3.80 m <sup>3</sup> (5.00 yd <sup>3</sup> )															4.37 m <sup>3</sup> (5.72 yd <sup>3</sup> )				3.80 m <sup>3</sup> (5.00 yd <sup>3</sup> )			
			4.20 m <sup>3</sup> (5.50 yd <sup>3</sup> )															4.83 m <sup>3</sup> (6.32 yd <sup>3</sup> )				4.20 m <sup>3</sup> (5.50 yd <sup>3</sup> )			
			4.20 m <sup>3</sup> (5.50 yd <sup>3</sup> )															4.83 m <sup>3</sup> (6.32 yd <sup>3</sup> )				4.20 m <sup>3</sup> (5.50 yd <sup>3</sup> )			
Aggregate Handler Package	Pin On	Material Handling	4.20 m <sup>3</sup> (5.50 yd <sup>3</sup> )															4.83 m <sup>3</sup> (6.32 yd <sup>3</sup> )				4.20 m <sup>3</sup> (5.50 yd <sup>3</sup> )			
			3.80 m <sup>3</sup> (5.00 yd <sup>3</sup> )															4.37 m <sup>3</sup> (5.72 yd <sup>3</sup> )				3.80 m <sup>3</sup> (5.00 yd <sup>3</sup> )			
			4.00 m <sup>3</sup> (5.25 yd <sup>3</sup> )															4.60 m <sup>3</sup> (6.02 yd <sup>3</sup> )				4.00 m <sup>3</sup> (5.25 yd <sup>3</sup> )			
Material Density	lb/yd <sup>3</sup>	1,180	1,348	1,517	1,685	1,854	2,022	2,191	2,359	2,528	2,696	2,865	3,033	3,202	3,370	3,539	3,707	3,876	4,044	4,213					
Bucket Fill Factors	115% 110% 105% 100% 95%																								

**Note:** All buckets are showing Bolt-On Edges.



# 966M/972M Wheel Loaders Specifications

## 966M Operating Specifications with Buckets

Linkage		Standard Linkage			Standard Linkage			High Lift Linkage Change**
Bucket Type		General Purpose – Pin On						
Edge Type		Bolt-On Cutting Edges	Teeth and Segments	Tips	Bolt-On Cutting Edges	Teeth and Segments	Tips	
Capacity – Rated	m <sup>3</sup>	3.80	3.80	3.60	4.00	4.00	3.80	—
	yd <sup>3</sup>	5.00	5.00	4.75	5.25	5.25	5.00	—
Capacity – Rated at 110% Fill Factor	m <sup>3</sup>	4.18	4.18	3.96	4.40	4.40	4.18	—
	yd <sup>3</sup>	5.47	5.47	5.18	5.75	5.75	5.47	—
Width	mm	3220	3271	3271	3220	3271	3271	—
	ft/in	10'6"	10'8"	10'8"	10'6"	10'8"	10'8"	—
16† Dump Clearance at Maximum Lift and 45° Discharge	mm	3067	2915	2915	3058	2905	2905	558
	ft/in	10'0"	9'6"	9'6"	10'0"	9'6"	9'6"	1'10"
17† Reach at Maximum Lift and 45° Discharge	mm	1292	1432	1432	1299	1438	1438	-24
	ft/in	4'2"	4'8"	4'8"	4'3"	4'8"	4'8"	-0.9"
Reach at Level Lift Arm and Bucket Level	mm	2704	2908	2908	2715	2920	2920	405
	ft/in	8'10"	9'6"	9'6"	8'10"	9'6"	9'6"	1'4"
A† Digging Depth	mm	124	124	94	124	124	94	-25
	in	4.9"	4.9"	3.7"	4.9"	4.9"	3.7"	-1"
12† Shipping Length (with Bucket)	mm	8651	8876	8876	8663	8888	8888	820
	ft/in	28'5"	29'2"	29'2"	28'6"	29'2"	29'2"	2'8"
B† Overall Height with Bucket at Maximum Lift	mm	5788	5788	5788	5902	5902	5902	558
	ft/in	19'0"	19'0"	19'0"	19'5"	19'5"	19'5"	1'10"
Loader Clearance Circle with Bucket at Carry Position	mm	14 973	15 142	15 142	14 979	15 148	15 148	479
	ft/in	49'2"	49'9"	49'9"	49'2"	49'9"	49'9"	1'7"
Static Tipping Load, Straight (With Tire Deflection)*	kg	16 874	16 693	16 891	16 856	16 674	16 908	22
	lb	37,192	36,791	37,229	37,152	36,750	37,266	48
Static Tipping Load, Straight (No Tire Deflection)*	kg	18 045	17 860	18 048	18 037	17 851	18 088	-75
	lb	39,772	39,364	39,777	39,754	39,344	39,867	-165
Static Tipping Load, Articulated (With Tire Deflection)*	kg	14 876	14 693	14 883	14 855	14 671	14 890	-163
	lb	32,788	32,384	32,804	32,741	32,335	32,818	-359
Static Tipping Load, Articulated (No Tire Deflection)*	kg	16 029	15 844	16 023	16 017	15 831	16 052	-225
	lb	35,329	34,921	35,315	35,303	34,893	35,379	-496
Breakout Force	kN	187	185	199	185	183	197	-17
	lbf	42,151	41,781	44,901	41,695	41,326	44,390	-37
Operating Weight*	kg	23 112	23 250	23 087	23 164	23 302	23 139	1612
	lb	50,938	51,242	50,883	51,053	51,357	50,997	3,553

\*Static tipping loads and operating weights shown are based on a machine configuration with Michelin 26.5R25 XHA2 L3 radial tires, full fluids, operator, standard counterweight, cold start, roading fenders, Product Link, manual diff lock/open axles (front/rear), power train guard, secondary steering and sound suppression.

\*\*Maximum values.

(With Tire Deflection) Full compliance to ISO 14397-1 (2007) Sections 1 thru 6, which requires 2% verification between calculations and testing.

(No Tire Deflection) Compliance to ISO 14397-1 (2007) Sections 1 thru 5.

†Illustration shown with Dimension charts.

# 966M/972M Wheel Loaders Specifications

## 966M Operating Specifications with Buckets

Linkage		Standard Linkage			Standard Linkage			High Lift Linkage Change**
Bucket Type		General Purpose – Pin On			General Purpose – Fusion QC			
Edge Type		Bolt-On Cutting Edges	Teeth and Segments	Tips	Bolt-On Cutting Edges	Teeth and Segments	Tips	
Capacity – Rated	m <sup>3</sup>	4.20	4.20	4.00	3.80	3.80	3.60	—
	yd <sup>3</sup>	5.50	5.50	5.25	5.00	5.00	4.75	—
Capacity – Rated at 110% Fill Factor	m <sup>3</sup>	4.62	4.62	4.40	4.18	4.18	3.96	—
	yd <sup>3</sup>	6.04	6.04	5.75	5.47	5.47	5.18	—
Width	mm	3220	3271	3271	3220	3271	3271	—
	ft/in	10'6"	10'8"	10'8"	10'6"	10'8"	10'8"	—
16† Dump Clearance at Maximum Lift and 45° Discharge	mm	2991	2837	2837	3038	2886	2886	558
	ft/in	9'9"	9'3"	9'3"	9'11"	9'5"	9'5"	1'10"
17† Reach at Maximum Lift and 45° Discharge	mm	1353	1490	1490	1327	1466	1466	-25
	ft/in	4'5"	4'10"	4'10"	4'4"	4'9"	4'9"	-1"
Reach at Level Lift Arm and Bucket Level	mm	2803	3008	3008	2748	2953	2953	404
	ft/in	9'2"	9'10"	9'10"	9'0"	9'8"	9'8"	1'4"
A† Digging Depth	mm	124	124	94	124	124	94	-25
	in	4.9"	4.9"	3.7"	4.9"	4.9"	3.7"	-1"
12† Shipping Length (with Bucket)	mm	8750	8975	8975	8696	8921	8921	820
	ft/in	28'9"	29'6"	29'6"	28'7"	29'4"	29'4"	2'8"
B† Overall Height with Bucket at Maximum Lift	mm	5902	5902	5902	5803	5803	5803	558
	ft/in	19'5"	19'5"	19'5"	19'1"	19'1"	19'1"	1'10"
Loader Clearance Circle with Bucket at Carry Position	mm	15 022	15 193	15 193	14 988	15 160	15 160	487
	ft/in	49'4"	49'11"	49'11"	49'3"	49'9"	49'9"	1'7"
Static Tipping Load, Straight (With Tire Deflection)*	kg	16 656	16 473	16 714	16 299	16 118	16 461	51
	lb	36,711	36,307	36,839	35,923	35,524	36,281	112
Static Tipping Load, Straight (No Tire Deflection)*	kg	17 828	17 641	17 886	17 442	17 258	17 617	-44
	lb	39,293	38,881	39,421	38,444	38,038	38,828	-97
Static Tipping Load, Articulated (With Tire Deflection)*	kg	14 668	14 483	14 709	14 323	14 140	14 470	-137
	lb	32,329	31,921	32,420	31,568	31,166	31,892	-302
Static Tipping Load, Articulated (No Tire Deflection)*	kg	15 822	15 636	15 864	15 453	15 269	15 611	-196
	lb	34,873	34,461	34,964	34,059	33,653	34,408	-432
Breakout Force	kN	173	171	184	180	179	192	-16
	lbf	38,984	38,618	41,343	40,632	40,264	43,192	-35
Operating Weight*	kg	23 220	23 358	23 195	23 529	23 667	23 504	1612
	lb	51,176	51,480	51,121	51,857	52,161	51,802	3,553

\*Static tipping loads and operating weights shown are based on a machine configuration with Michelin 26.5R25 XHA2 L3 radial tires, full fluids, operator, standard counterweight, cold start, roading fenders, Product Link, manual diff lock/open axles (front/rear), power train guard, secondary steering and sound suppression.

\*\*Maximum values.

(With Tire Deflection) Full compliance to ISO 14397-1 (2007) Sections 1 thru 6, which requires 2% verification between calculations and testing.

(No Tire Deflection) Compliance to ISO 14397-1 (2007) Sections 1 thru 5.

†Illustration shown with Dimension charts.

# 966M/972M Wheel Loaders Specifications

## 966M Operating Specifications with Buckets

Linkage		Standard Linkage			Standard Linkage			High Lift Linkage Change**
Bucket Type		General Purpose – Fusion QC			Material Handling – Pin On			
Edge Type		Bolt-On Cutting Edges	Teeth and Segments	Tips	Bolt-On Cutting Edges	Teeth and Segments	Tips	
Capacity – Rated	m <sup>3</sup>	4.20	4.20	4.00	4.20	4.20	4.04	—
	yd <sup>3</sup>	5.50	5.50	5.25	5.50	5.50	5.30	—
Capacity – Rated at 110% Fill Factor	m <sup>3</sup>	4.62	4.62	4.40	4.62	4.62	4.44	—
	yd <sup>3</sup>	6.04	6.04	5.75	6.04	6.04	5.81	—
Width	mm	3220	3271	3271	3220	3271	3271	—
	ft/in	10'6"	10'8"	10'8"	10'6"	10'8"	10'8"	—
16† Dump Clearance at Maximum Lift and 45° Discharge	mm	2960	2806	2806	2949	2787	2787	559
	ft/in	9'8"	9'2"	9'2"	9'8"	9'1"	9'1"	1'10"
17† Reach at Maximum Lift and 45° Discharge	mm	1398	1536	1536	1245	1372	1372	-24
	ft/in	4'7"	5'0"	5'0"	4'1"	4'6"	4'6"	-0.9"
Reach at Level Lift Arm and Bucket Level	mm	2858	3062	3062	2774	2978	2978	405
	ft/in	9'4"	10'0"	10'0"	9'1"	9'9"	9'9"	1'4"
A† Digging Depth	mm	116	116	86	124	124	94	-25
	in	4.5"	4.5"	3.4"	4.9"	4.9"	3.7"	-1"
12† Shipping Length (with Bucket)	mm	8798	9024	9024	8721	8946	8946	822
	ft/in	28'11"	29'8"	29'8"	28'8"	29'5"	29'5"	2'8"
B† Overall Height with Bucket at Maximum Lift	mm	5960	5960	5960	5901	5901	5901	558
	ft/in	19'7"	19'7"	19'7"	19'5"	19'5"	19'5"	1'10"
Loader Clearance Circle with Bucket at Carry Position	mm	15 038	15 212	15 212	15 008	15 178	15 178	493
	ft/in	49'5"	49'11"	49'11"	49'3"	49'10"	49'10"	1'7"
Static Tipping Load, Straight (With Tire Deflection)*	kg	16 031	15 850	16 186	16 580	16 398	16 729	95
	lb	35,334	34,933	35,675	36,544	36,143	36,871	209
Static Tipping Load, Straight (No Tire Deflection)*	kg	17 173	16 988	17 339	17 731	17 546	17 890	34
	lb	37,850	37,442	38,216	39,080	38,672	39,430	75
Static Tipping Load, Articulated (With Tire Deflection)*	kg	14 075	13 892	14 216	14 605	14 421	14 738	-106
	lb	31,022	30,618	31,332	32,190	31,786	32,483	-234
Static Tipping Load, Articulated (No Tire Deflection)*	kg	15 204	15 019	15 355	15 740	15 555	15 883	-158
	lb	33,510	33,102	33,843	34,691	34,283	35,006	-348
Breakout Force	kN	166	164	176	177	175	188	-15
	lbf	37,382	37,023	39,561	39,834	39,468	42,297	-33
Operating Weight*	kg	23 592	23 730	23 567	23 217	23 355	23 192	1612
	lb	51,997	52,301	51,941	51,170	51,474	51,114	3,553

\*Static tipping loads and operating weights shown are based on a machine configuration with Michelin 26.5R25 XHA2 L3 radial tires, full fluids, operator, standard counterweight, cold start, roading fenders, Product Link, manual diff lock/open axles (front/rear), power train guard, secondary steering and sound suppression.

\*\*Maximum values.

(With Tire Deflection) Full compliance to ISO 14397-1 (2007) Sections 1 thru 6, which requires 2% verification between calculations and testing.

(No Tire Deflection) Compliance to ISO 14397-1 (2007) Sections 1 thru 5.

†Illustration shown with Dimension charts.

# 966M/972M Wheel Loaders Specifications

## 966M Operating Specifications with Buckets – Aggregate Handler

Package		Aggregate Handler			Aggregate Handler		Aggregate Handler
Bucket Type		General Purpose – Pin On			General Purpose – Fusion QC		Material Handling – Pin On
Edge Type		Bolt-On Cutting Edges	Bolt-On Cutting Edges	Bolt-On Cutting Edges	Bolt-On Cutting Edges	Bolt-On Cutting Edges	Bolt-On Cutting Edges
Capacity – Rated	m <sup>3</sup>	3.80	4.00	4.20	3.80	4.20	4.20
	yd <sup>3</sup>	5.00	5.25	5.50	5.00	5.50	5.50
Capacity – Rated at 110% Fill Factor	m <sup>3</sup>	4.18	4.40	4.62	4.18	4.62	4.62
	yd <sup>3</sup>	5.47	5.75	6.04	5.47	6.04	6.04
Width	mm	3220	3220	3220	3220	3220	3220
	ft/in	10'6"	10'6"	10'6"	10'6"	10'6"	10'6"
<b>16</b> † Dump Clearance at Maximum Lift and 45° Discharge	mm	3067	3058	2991	3038	2960	2967
	ft/in	10'0"	10'0"	9'9"	9'11"	9'8"	9'8"
<b>17</b> † Reach at Maximum Lift and 45° Discharge	mm	1292	1299	1353	1327	1398	1228
	ft/in	4'2"	4'3"	4'5"	4'4"	4'7"	4'0"
Reach at Level Lift Arm and Bucket Level	mm	2704	2715	2803	2748	2858	2749
	ft/in	8'10"	8'10"	9'2"	9'0"	9'4"	9'0"
<b>A</b> † Digging Depth	mm	124	124	124	124	116	124
	in	4.9"	4.9"	4.9"	4.9"	4.5"	4.9"
<b>12</b> † Shipping Length (with Bucket)	mm	8657	8669	8756	8702	8804	8702
	ft/in	28'5"	28'6"	28'9"	28'7"	28'11"	28'7"
<b>B</b> † Overall Height with Bucket at Maximum Lift	mm	5788	5902	5902	5803	5960	5874
	ft/in	19'0"	19'5"	19'5"	19'1"	19'7"	19'4"
Loader Clearance Circle with Bucket at Carry Position	mm	14 973	14 979	15 022	14 988	15 038	14 995
	ft/in	49'2"	49'2"	49'4"	49'3"	49'5"	49'3"
Static Tipping Load, Straight (With Tire Deflection)*	kg	18 475	18 459	18 247	17 880	17 595	18 199
	lb	40,719	40,684	40,217	39,408	38,780	40,111
Static Tipping Load, Straight (No Tire Deflection)*	kg	19 797	19 792	19 570	19 171	18 884	19 496
	lb	43,634	43,623	43,134	42,254	41,622	42,969
Static Tipping Load, Articulated (With Tire Deflection)*	kg	16 232	16 212	16 015	15 662	15 399	15 982
	lb	35,777	35,732	35,299	34,519	33,940	35,225
Static Tipping Load, Articulated (No Tire Deflection)*	kg	17 540	17 531	17 325	16 944	16 680	17 266
	lb	38,658	38,638	38,185	37,345	36,762	38,056
Breakout Force	kN	187	185	173	180	166	180
	lbf	42,151	41,695	38,984	40,632	37,382	40,629
Operating Weight*	kg	23 807	23 859	23 915	24 224	24 287	23 869
	lb	52,470	52,584	52,708	53,389	53,528	52,606

\*Static tipping loads and operating weights shown are based on a machine configuration with Michelin 26.5R25 XHA2 L3 radial tires, full fluids, operator, aggregate counterweight, cold start, roading fenders, Product Link, manual diff lock/open axles (front/rear), power train guard, secondary steering and sound suppression. If a rock bucket is added, those values are with Michelin 26.5R25 XLDD2 L5 tires.

(With Tire Deflection) Full compliance to ISO 14397-1 (2007) Sections 1 thru 6, which requires 2% verification between calculations and testing.

(No Tire Deflection) Compliance to ISO 14397-1 (2007) Sections 1 thru 5.

†Illustration shown with Dimension charts.



# 966M/972M Wheel Loaders Specifications

## 972M Operating Specifications with Buckets

Linkage		Standard Linkage			Standard Linkage			High Lift Linkage Change**
Bucket Type		General Purpose – Pin On						
Edge Type		Bolt-On Cutting Edges	Teeth and Segments	Tips	Bolt-On Cutting Edges	Teeth and Segments	Tips	
Capacity – Rated	m <sup>3</sup>	4.60	4.60	4.40	4.80	4.80	4.60	—
	yd <sup>3</sup>	6.00	6.00	5.75	6.25	6.25	6.00	—
Capacity – Rated at 110% Fill Factor	m <sup>3</sup>	5.06	5.06	4.84	5.28	5.28	5.06	—
	yd <sup>3</sup>	6.62	6.62	6.33	6.91	6.91	6.62	—
Width	mm	3220	3271	3271	3220	3271	3271	—
	ft/in	10'6"	10'8"	10'8"	10'6"	10'8"	10'8"	—
16† Dump Clearance at Maximum Lift and 45° Discharge	mm	3187	3033	3033	3154	2999	2999	336
	ft/in	10'5"	9'11"	9'11"	10'4"	9'10"	9'10"	1'1"
17† Reach at Maximum Lift and 45° Discharge	mm	1328	1465	1465	1357	1493	1493	23
	ft/in	4'4"	4'9"	4'9"	4'5"	4'10"	4'10"	0.9"
Reach at Level Lift Arm and Bucket Level	mm	2969	3174	3174	3014	3219	3219	274
	ft/in	9'8"	10'4"	10'4"	9'10"	10'6"	10'6"	11"
A† Digging Depth	mm	103	103	73	103	103	73	-5
	in	4"	4"	2.8"	4"	4"	2.8"	-0.2"
12† Shipping Length (with Bucket)	mm	9270	9494	9494	9315	9539	9539	335
	ft/in	30'5"	31'2"	31'2"	30'7"	31'4"	31'4"	1'1"
B† Overall Height with Bucket at Maximum Lift	mm	6195	6195	6195	6031	6031	6031	336
	ft/in	20'4"	20'4"	20'4"	19'10"	19'10"	19'10"	1'1"
Loader Clearance Circle with Bucket at Carry Position	mm	15 192	15 369	15 369	15 216	15 394	15 394	323
	ft/in	49'11"	50'6"	50'6"	50'0"	50'7"	50'7"	1'0.7"
Static Tipping Load, Straight (With Tire Deflection)*	kg	18 477	18 293	18 550	18 502	18 318	20 545	-1592
	lb	40,723	40,319	40,884	40,779	40,372	45,281	-3,508
Static Tipping Load, Straight (No Tire Deflection)*	kg	19 724	19 537	19 796	19 755	19 567	22 192	-1752
	lb	43,473	43,061	43,631	43,542	43,127	48,912	-3,863
Static Tipping Load, Articulated (With Tire Deflection)*	kg	16 135	15 950	16 188	16 164	15 978	17 927	-1423
	lb	35,563	35,155	35,680	35,626	35,215	39,512	-3,137
Static Tipping Load, Articulated (No Tire Deflection)*	kg	17 387	17 200	17 439	17 421	17 233	19 558	-1598
	lb	38,322	37,910	38,437	38,396	37,982	43,107	-3,521
Breakout Force	kN	202	201	214	196	194	207	-6
	lbf	45,482	45,173	48,227	44,075	43,766	46,655	-1,368
Operating Weight*	kg	24 969	25 106	24 943	24 897	25 034	24 871	84
	lb	55,030	55,334	54,974	54,871	55,175	54,816	186

\*Static tipping loads and operating weights shown are based on a machine configuration with Michelin 26.5R25 XHA2 L3 radial tires, full fluids, operator, standard counterweight, cold start, roading fenders, Product Link, manual diff lock/open axles (front/rear), power train guard, secondary steering and sound suppression.

\*\*Maximum values.

(With Tire Deflection) Full compliance to ISO 14397-1 (2007) Sections 1 thru 6, which requires 2% verification between calculations and testing.

(No Tire Deflection) Compliance to ISO 14397-1 (2007) Sections 1 thru 5.

†Illustration shown with Dimension charts.

# 966M/972M Wheel Loaders Specifications

## 972M Operating Specifications with Buckets

Linkage		Standard Linkage			Standard Linkage			High Lift Linkage Change**
Bucket Type		General Purpose – Pin On			General Purpose – Fusion QC			
Edge Type		Bolt-On Cutting Edges	Teeth and Segments	Tips	Bolt-On Cutting Edges	Teeth and Segments	Tips	
Capacity – Rated	m <sup>3</sup>	5.00	5.00	4.80	4.40	4.40	4.20	—
	yd <sup>3</sup>	6.50	6.50	6.25	5.75	5.75	5.50	—
Capacity – Rated at 110% Fill Factor	m <sup>3</sup>	5.50	5.50	5.28	4.84	4.84	4.62	—
	yd <sup>3</sup>	7.19	7.19	6.91	6.33	6.33	6.04	—
Width	mm	3220	3271	3271	3220	3271	3271	—
	ft/in	10'6"	10'8"	10'8"	10'6"	10'8"	10'8"	—
<b>16</b> † Dump Clearance at Maximum Lift and 45° Discharge	mm	3137	2982	2982	3200	3047	3047	336
	ft/in	10'3"	9'9"	9'9"	10'6"	9'11"	9'11"	1'1"
<b>17</b> † Reach at Maximum Lift and 45° Discharge	mm	1372	1508	1508	1327	1465	1465	23
	ft/in	4'6"	4'11"	4'11"	4'4"	4'9"	4'9"	0.9"
Reach at Level Lift Arm and Bucket Level	mm	3037	3242	3242	2958	3163	3163	274
	ft/in	9'11"	10'7"	10'7"	9'8"	10'4"	10'4"	11"
<b>A</b> † Digging Depth	mm	103	103	73	103	103	73	-5
	in	4"	4"	2.8"	4"	4"	2.8"	-0.2"
<b>12</b> † Shipping Length (with Bucket)	mm	9338	9562	9562	9259	9483	9483	335
	ft/in	30'8"	31'5"	31'5"	30'5"	31'2"	31'2"	1'1"
<b>B</b> † Overall Height with Bucket at Maximum Lift	mm	6284	6284	6284	6205	6205	6205	336
	ft/in	20'8"	20'8"	20'8"	20'5"	20'5"	20'5"	1'1"
Loader Clearance Circle with Bucket at Carry Position	mm	15 229	15 407	15 407	15 180	15 359	15 359	324
	ft/in	50'0"	50'7"	50'7"	49'10"	50'5"	50'5"	1'0.8"
Static Tipping Load, Straight (With Tire Deflection)*	kg	18 600	18 415	18 651	18 081	17 899	18 257	-1608
	lb	40,996	40,588	41,108	39,851	39,450	40,240	-3,545
Static Tipping Load, Straight (No Tire Deflection)*	kg	19 856	19 668	19 906	19 317	19 131	19 507	-1771
	lb	43,764	43,348	43,873	42,576	42,166	42,993	-3,903
Static Tipping Load, Articulated (With Tire Deflection)*	kg	16 264	16 076	16 297	15 749	15 565	15 907	-1444
	lb	35,845	35,433	35,919	34,712	34,307	35,060	-3,181
Static Tipping Load, Articulated (No Tire Deflection)*	kg	17 521	17 332	17 553	16 992	16 807	17 163	-1620
	lb	38,617	38,200	38,687	37,452	37,043	37,828	-3,570
Breakout Force	kN	198	197	210	203	202	216	-6
	lbf	44,634	44,325	47,205	45,788	45,479	48,572	-1,378
Operating Weight*	kg	25 010	25 147	24 984	25 327	25 464	25 301	84
	lb	55,120	55,424	55,065	55,819	56,123	55,763	186

\*Static tipping loads and operating weights shown are based on a machine configuration with Michelin 26.5R25 XHA2 L3 radial tires, full fluids, operator, standard counterweight, cold start, roading fenders, Product Link, manual diff lock/open axles (front/rear), power train guard, secondary steering and sound suppression.

\*\*Maximum values.

(With Tire Deflection) Full compliance to ISO 14397-1 (2007) Sections 1 thru 6, which requires 2% verification between calculations and testing.

(No Tire Deflection) Compliance to ISO 14397-1 (2007) Sections 1 thru 5.

†Illustration shown with Dimension charts.

# 966M/972M Wheel Loaders Specifications

## 972M Operating Specifications with Buckets

Linkage		Standard Linkage			High Lift Linkage Change**	Extended Linkage		
Bucket Type		Material Handling – Pin On				General Purpose – Fusion QC		
Edge Type		Bolt-On Cutting Edges	Teeth and Segments	Tips		Bolt-On Cutting Edges	Teeth and Segments	Tips
Capacity – Rated	m <sup>3</sup>	4.60	4.60	4.40	—	4.90	4.90	4.70
	yd <sup>3</sup>	6.00	6.00	5.75	—	6.41	6.41	6.15
Capacity – Rated at 110% Fill Factor	m <sup>3</sup>	5.06	5.06	4.84	—	5.39	5.39	5.17
	yd <sup>3</sup>	6.62	6.62	6.33	—	7.05	7.05	6.76
Width	mm	3220	3271	3271	—	3220	3271	3271
	ft/in	10'6"	10'8"	10'8"	—	10'6"	10'8"	10'8"
<b>16</b> † Dump Clearance at Maximum Lift and 45° Discharge	mm	3120	2957	2957	336	2899	2744	2744
	ft/in	10'2"	9'8"	9'8"	1'1"	9'6"	9'0"	9'0"
<b>17</b> † Reach at Maximum Lift and 45° Discharge	mm	1251	1378	1378	23	1449	1586	1586
	ft/in	4'1"	4'6"	4'6"	0.9"	4'9"	5'2"	5'2"
Reach at Level Lift Arm and Bucket Level	mm	2979	3184	3184	274	2940	3145	3145
	ft/in	9'9"	10'5"	10'5"	11"	9'7"	10'3"	10'3"
<b>A</b> † Digging Depth	mm	103	103	73	-5	115	115	85
	in	4"	4"	2.8"	-0.2"	4.5"	4.5"	3.3"
<b>12</b> † Shipping Length (with Bucket)	mm	9280	9504	9504	335	9200	9425	9425
	ft/in	30'6"	31'3"	31'3"	1'1"	30'3"	31'0"	31'0"
<b>B</b> † Overall Height with Bucket at Maximum Lift	mm	6162	6162	6162	336	6126	6126	6126
	ft/in	20'3"	20'3"	20'3"	1'1"	20'2"	20'2"	20'2"
Loader Clearance Circle with Bucket at Carry Position	mm	15 197	15 375	15 375	334	15 081	15 255	15 255
	ft/in	49'11"	50'6"	50' 6"	1'1"	49'6"	50'1"	50'1"
Static Tipping Load, Straight (With Tire Deflection)*	kg	18 412	18 229	18 468	-1598	19 411	19 225	19 590
	lb	40,580	40,177	40,704	-3,521	42,781	42,372	43,177
Static Tipping Load, Straight (No Tire Deflection)*	kg	19 640	19 453	19 695	-1757	20 885	20 695	21 079
	lb	43,286	42,875	43,409	-3,871	46,032	45,612	46,460
Static Tipping Load, Articulated (With Tire Deflection)*	kg	16 081	15 896	16 119	-1429	16 920	16 732	17 082
	lb	35,442	35,035	35,526	-3,149	37,293	36,878	37,649
Static Tipping Load, Articulated (No Tire Deflection)*	kg	17 313	17 127	17 351	-1601	18 387	18 197	18 562
	lb	38,159	37,749	38,242	-3,528	40,526	40,106	40,912
Breakout Force	kN	201	199	213	-7	198	196	209
	lbf	45,174	44,865	47,882	-1,647	44,570	44,204	47,022
Operating Weight*	kg	24 964	25 101	24 938	85	25 283	25 421	25 258
	lb	55,019	55,323	54,963	186	55,724	56,028	55,668

\*Static tipping loads and operating weights shown are based on a machine configuration with Michelin 26.5R25 XHA2 L3 radial tires, full fluids, operator, standard counterweight, cold start, roading fenders, Product Link, manual diff lock/open axles (front/rear), power train guard, secondary steering and sound suppression.

\*\*Maximum values.

(With Tire Deflection) Full compliance to ISO 14397-1 (2007) Sections 1 thru 6, which requires 2% verification between calculations and testing.

(No Tire Deflection) Compliance to ISO 14397-1 (2007) Sections 1 thru 5.

†Illustration shown with Dimension charts.



# 966M/972M Wheel Loaders Specifications

## 972M Operating Specifications with Buckets – Aggregate Handler

Linkage		Aggregate Handler		
Bucket Type		General Purpose – Pin On		
Edge Type		Bolt-On Cutting Edges	Bolt-On Cutting Edges	Bolt-On Cutting Edges
Capacity – Rated	m <sup>3</sup>	5.10	5.30	5.50
	yd <sup>3</sup>	6.67	6.93	7.19
Capacity – Rated at 110% Fill Factor	m <sup>3</sup>	5.61	5.83	6.05
	yd <sup>3</sup>	7.34	7.63	7.91
Width	mm	3357	3357	3357
	ft/in	11'0"	11'0"	11'0"
<b>16</b> † Dump Clearance at Maximum Lift and 45° Discharge	mm	3127	3100	3072
	ft/in	10'3"	10'2"	10'0"
<b>17</b> † Reach at Maximum Lift and 45° Discharge	mm	1375	1399	1424
	ft/in	4'6"	4'7"	4'8"
Reach at Level Lift Arm and Bucket Level	mm	3046	3083	3121
	ft/in	9'11"	10'1"	10'2"
<b>A</b> † Digging Depth	mm	108	108	108
	in	4.2"	4.2"	4.2"
<b>12</b> † Shipping Length (with Bucket)	mm	9037	9074	9112
	ft/in	29'8"	29'10"	29'11"
<b>B</b> † Overall Height with Bucket at Maximum Lift	mm	6235	6272	6293
	ft/in	20'6"	20'7"	20'8"
Loader Clearance Circle with Bucket at Carry Position	mm	15 362	15 382	15 403
	ft/in	50'5"	50'6"	50'7"
Static Tipping Load, Straight (With Tire Deflection)*	kg	19 316	19 242	19 172
	lb	42,574	42,409	42,255
Static Tipping Load, Straight (No Tire Deflection)*	kg	20 669	20 600	20 537
	lb	45,556	45,403	45,263
Static Tipping Load, Articulated (With Tire Deflection)*	kg	16 799	16 726	16 658
	lb	37,026	36,865	36,716
Static Tipping Load, Articulated (No Tire Deflection)*	kg	18 165	18 098	18 036
	lb	40,036	39,888	39,753
Breakout Force	kN	190	185	180
	lbf	42,755	41,650	40,573
Operating Weight*	kg	25 790	25 832	25 870
	lb	56,840	56,933	57,016

\*Static tipping loads and operating weights shown are based on a machine configuration with Michelin 26.5R25 XHA2 L3 radial tires, full fluids, operator, standard counterweight, cold start, roading fenders, Product Link, manual diff lock/open axles (front/rear), power train guard, secondary steering and sound suppression.

\*\*Maximum values.

(With Tire Deflection) Full compliance to ISO 14397-1 (2007) Sections 1 thru 6, which requires 2% verification between calculations and testing.

(No Tire Deflection) Compliance to ISO 14397-1 (2007) Sections 1 thru 5.

†Illustration shown with Dimension charts.

## Standard Equipment

Standard equipment may vary. Consult your Cat dealer for details.

### OPERATOR ENVIRONMENT

- Cab, pressurized and sound suppressed (ROPS/FOPS)
- Viscous mounts
- Multi-function 18 cm (7 in) color touch-screen display for rear vision camera, clock and machine parameters
- EH controls, SAL (single axis lever) lift and tilt function
- Steering, EH joystick, speed sensing with force feedback
- Radio ready (entertainment) includes antenna, speakers and converter (12V, 10-amp)
- Air conditioner, heater, and defroster (auto temp and fan)
- EH parking brake
- Beverage holders (2) with storage compartment for cell phone/MP3 player
- Bucket/work tool function lockout
- Coat hook (2)
- Cab air filter
- Ergonomic cab access ladders and handrails
- Horn, electric
- Light, two dome (cab)
- Mirrors, rearview external with integrated spot mirrors
- Post mounted membrane 16 switch keypad
- 2 receptacles, 12V
- Seat, Cat Comfort (cloth) air suspension
- Seat belt, 51 mm (2 in) retractable, with indicator
- Sun visor, front
- Wet-arm wipers/washers front and rear, intermittent front wiper
- Window, sliding (left and right sides)
- Cab tie-off

### COMPUTERIZED MONITORING SYSTEM

- With following gauges:
  - Speedometer/tachometer
  - Digital gear range indicator
  - Diesel Exhaust Fluid (DEF) level (Tier 4 Final/Stage IV models)
  - Temperature: engine coolant, hydraulic oil, transmission oil
  - Fuel level

- With following warning indicators:
  - Regeneration
  - Temperature: axle oil, engine intake manifold
  - Pressure: engine oil, fuel pressure hi/low, primary steering oil, service brake oil
  - Battery voltage hi/low
  - Engine air filter restriction
  - Hydraulic oil filter restriction
  - Hydraulic oil low
  - Parking brake
  - DEF low level (Tier 4 Final/Stage IV models)
  - Transmission filter bypass

### ELECTRICAL AND LIGHTING

- Batteries (2), maintenance free 1,400 CCA
- Ignition key; start/stop switch
- Starter, electric, heavy duty
- Starting and charging system (24V)
- Lighting system:
  - Four halogen work lights (cab mounted)
  - Two halogen roading lights (with signals)
  - Two halogen rear vision lights (hood mounted)
- Alarm, back-up
- Alternator, 145-amp brushed
- Main disconnect switch
- Receptacle start (cables not included)

### CAT CONNECT TECHNOLOGIES

- Link technologies: Product Link
- Detect technologies: rear vision camera

### POWER TRAIN

- Engine, Cat C9.3 ACERT – meets Tier 3/Stage IIIA equivalent or Tier 4 Final/Stage IV emission standards
- Cat Clean Emissions Module (CEM) with Diesel Particulate Filter (DPF) and remote Diesel Exhaust Fluid (DEF) tank and pump (Tier 4 Final/Stage IV models)
- Fuel priming pump (electric)
- Fuel/water separator
- Precleaner, engine air intake
- Economy Mode (selectable)
- Transmission, automatic planetary power shift (4F/4R)
- Torque converter, locking clutch with free wheel stator

- Switch, transmission neutralizer lockout
- Axles, manually actuated differential lock front axle, open differential rear axle
- Axles, ecology drains
- Brakes, full hydraulic enclosed wet-disc with Integrated Braking System (IBS)
- Brake wear indicators
- Parking brake, disc and caliper
- Fan, radiator, on demand

### LINKAGE

- Linkage, Z-bar, cast crosstube/tilt lever
- Kickout, lift and tilt, automatic

### HYDRAULICS

- Hydraulic system, load sensing
- Steering, load sensing
- Ride control, 2V
- Remote diagnostic pressure taps
- Hoses, Cat XT™
- Oil sampling valves

### FLUIDS

- Premixed extended life coolant with freeze protection to –34° C (–29° F)

### OTHER STANDARD EQUIPMENT

- Hood, non-metallic power tilting
- Service centers (electrical and hydraulic)
- Platform, window washing
- Auto idle shutdown
- Fenders, front with mud-flap/rear with extension
- Ecology drains for engine, transmission, and hydraulics
- Ether aid ready
- Grill, airborne debris
- Filters: fuel, engine air, engine oil, hydraulic oil, transmission
- Fuel cooler
- Grease zerks
- Hitch, drawbar with pin
- Precleaner rain cap
- Sight gauges: engine coolant, hydraulic oil, and transmission oil level
- Toolbox
- Vandalism protection caplocks

## Optional Equipment

Optional equipment may vary. Consult your Cat dealer for details.

### OPERATOR ENVIRONMENT

- Door, remote opening system
- Cover, HVAC metallic
- EH controls, SAL 3<sup>rd</sup> function
  - Additional roller switch for 4<sup>th</sup> function
- EH controls, joystick lift and tilt
  - Additional integrated roller switches for 3<sup>rd</sup> and 4<sup>th</sup> functions
- Filter, carbon fresh air
- Mirrors, heated rearview external with integrated spot mirrors
- Precleaner, HVAC
- Precleaner, HVAC (RESPA)
- Radio, AM/FM/USB/MP3 Bluetooth
- Radio, AM/FM/CD/USB/MP3 Bluetooth
- Radio, AM/FM/CD/USB/MP3 Bluetooth with Satellite Sirius and XM
- Radio, CB ready
- Seat, heated air suspension
- Seat belt, 76 mm (3 in) retractable, with indicator
- Steering, EH wheel with directional FNR shifter and gear selector
  - Additional FNR with implement controls
- Roof, metallic
- Steering, secondary
- Sun visor, rear
- Windows, rubber mounted
- Windows, with front guard
- Windows, with heavy duty front guard
- Windows, with full guards front, rear and sides

### ELECTRICAL AND LIGHTING

- Four additional auxiliary halogen cab mounted work lights or
- Two additional auxiliary front HI LED and two additional auxiliary rear LED cab mounted work lights with 2 LED work lights in the radiator grill and LED front turn signals also includes replacement of the standard four halogen cab mounted work lights with four LED work lights (the standard offering and only roading light available is the halogen roading light)
- Warning amber strobe beacon
- Reversing strobes
- External seat belt indicator light
- Speed limiter – 20 km/h (Europe only)

### STARTERS, BATTERIES, AND ALTERNATORS

- Cold start – 120V
- Cold start – 240V

### CAT CONNECT TECHNOLOGIES

- Link technologies: VIMS™
- Payload technologies:
  - Aggregate Autodig
  - Cat Production Measurement
  - Printer, Cat Production Measurement
- Detect technologies: dedicated display for rear vision camera, full-time activation
- Machine Security System
- Cat Object Detection

### POWER TRAIN

- Axles
  - Automatic front/rear differential locks
  - Axle oil cooler
  - Extreme temperature seals
  - Seal guards
- Fan, VPF (variable pitch fan), automatic and manual control
- Radiator, high debris with wider fin spacing

### LINKAGE

- High lift
- Forestry (966 only)
- Extended capacity (972 only)
- Quick coupler ready

### WORK TOOLS

- Performance Series buckets
- Fusion quick coupler
- Forks, pallet
- Forks, logging

### HYDRAULICS

- 3<sup>rd</sup> function with Ride Control
  - Standard linkage
  - High lift linkage
  - Forestry linkage
- 4<sup>th</sup> function with Ride Control
  - Standard linkage
  - High lift linkage
  - Forestry linkage

### FLUIDS

- Premixed extended life coolant with freeze protection to –50° C (–58° F)

### OTHER OPTIONAL EQUIPMENT

- Fenders, roading
- Guard, power train
- Oil change, high speed engine
- Precleaner, turbine
- Precleaner, trash
- Wheel chocks

### OTHER OPTIONAL CONFIGURATIONS

- Aggregate Handler
- Industrial and Waste Handler
- Forestry (966 only)
- Steel Mill (972 only)

For more complete information on Cat products, dealer services, and industry solutions, visit us on the web at [www.cat.com](http://www.cat.com)

© 2016 Caterpillar  
All rights reserved

Materials and specifications are subject to change without notice. Featured machines in photos may include additional equipment. See your Cat dealer for available options.

CAT, CATERPILLAR, SAFETY.CAT.COM, their respective logos, "Caterpillar Yellow" and the "Power Edge" trade dress, as well as corporate and product identity used herein, are trademarks of Caterpillar and may not be used without permission.

VisionLink is a trademark of Trimble Navigation Limited, registered in the United States and in other countries.

AEHQ7740-01 (03-2016)  
Replaces AEHQ7740  
(Brazil, ANZ, NACD)



*Courtesy of Machine.Market*