

973D

Track Loader

CATERPILLAR[®]



Engine

Engine Model	Cat [®] C9 ACERT [™]	
Net Power – SAE J1349	196 kW	263 hp

Weights

Operating Weight	28 058 kg	61,857 lb
------------------	-----------	-----------

- Operating Weight: Includes coolant, lubricants, 100% fuel tank, General Purpose Bucket with long bolt-on teeth and segments and 75 kg/165 lb operator.

Buckets

Capacity – General Purpose	3.21 m ³	4.2 yd ³
Capacity – Multi-Purpose	3.05 m ³	3.92 yd ³

- Bucket capacities are with long bolt-on teeth and segments.

973D Features

Cat® C9 engine with ACERT™

10% more horsepower than C-series. Offers better fuel efficiency and reduced wear. It works at the point of combustion to optimize engine performance and provide low exhaust emissions.

Powerful Hydraulic System

Load sensing system works on-demand and adjusts flow pressure to match for precise and efficient control.

Comfortable Operator Station

Large, spacious cab and low-effort and ergonomic controls provide the operator a convenient and comfortable working area. The 973D is equipped with a tiltable cab.

Custom Products

Specific arrangements are available to extend machine capability to work under severe environmental conditions such as sanitary landfill, recycling site, demolition site, steel mill or soft ground conditions.

Contents

Engine	3
Hydraulics	4
Operator Station.....	5
Undercarriage	6
Structures.....	6
Work Tools.....	7
The All-Purpose Performer	8
Value Package.....	9
Serviceability	10
Product Link.....	11
Support	11
973D Track Loader Specifications.....	12
973D Standard Equipment	16
973D Optional Equipment.....	17
Notes.....	18



The Cat® 973D Track Loader is the only track loader in this size class. Furthermore, it leads the industry in operator comfort, performance and versatility.

Designed to be productive, this machine will give you complete satisfaction in a wide range of tough applications in the most efficient and productive way. Its design also delivers strength and durability with excellent control and unmatched ease of operation.

Discover how much more you can get with this one work force machine ...



Engine

Compact design ... Heavy-duty performance.

Cat® C9 Diesel Engine

The Cat® C9 is an 8.8 liter (537 in³) displacement, six-cylinder, in-line configured engine with hydraulically actuated electronic fuel injection or HEUI™. The 196 kW (263 hp) rated net power engine meet the latest worldwide emissions standards (10% more than C-series).

It uses ACERT™ Technology that provides advanced electronic control, precision fuel delivery and refined air management. This proven technology with thousands of hours in field operations, results in outstanding performances with a constant net horsepower.

Electronic Control ADEM™ A4

The Advanced Diesel Engine Management System continuously monitors important engine conditions and functions. ADEM™ A4 manages fuel delivery to get the best performance per liter of fuel. The controller uses sensors in fuel, air intake, exhaust and cooling systems and provides flexible fuel mapping, allowing the engine to respond quickly to varying application needs. ADEM A4 is the electronic brain of the machine that ensures optimal performance.

On-Demand Fan

This system offers numerous benefits, including better cooling performance, reduced plugging, enhanced cold weather operation and improved fuel economy. To reduce fan noise, the cooling fan is driven from a friction disc clutch, which is electrically controlled.

Hydraulics

Work smart ... Move more.



Hydrostatic Drive

The electronically controlled Hystat drive provides quick response for shorter cycles times and increased productivity.

The Hystat drive also offers independent power and efficient control of each track, with fast acceleration and infinitely variable speeds. The operator can command smooth machine turns and counter-rotation.

Load-Sensing Hydraulics

The 973D features a load sensing hydraulic system that automatically adjusts to operating conditions to provide only the hydraulic flow required by the implement for improved fuel efficiency. This modular hydraulic system delivers precise control with low effort operation and allows simultaneous lift, tilt and travel.

Position Sensing Cylinder

Position Sensing Cylinders (PSCs) are designed to allow for “smart” hydraulic systems. PSCs improve productivity by enhancing operator control. Operator can set lift and tilt kickouts at any position according to the applications without leaving the cab.

Electronics within the cylinder allow the hydraulic system to be linked into the machine’s electronics. This link enables the system to track the cylinder stroke, reducing operator effort, and increasing productivity.

PSCs allows the machine to use advanced automatic features for smooth start and stop cylinder motion, reducing vibration in the cab.

Automatic Kickouts

The standard programmable automatic kickouts provide flexibility and productivity for precise load and dump target heights. Tilt and lift kickouts are set by positioning the bucket or work tool and setting a rocker switch in the cab.



Operator Station

Superior comfort keeps you productive all day long.

Designed for Comfort

The D-Series cab is designed for operator comfort, convenience and to provide an excellent view to the bucket, tracks and ripper.

In particular, the air-suspension seat is ergonomically designed, fully adjustable and vibration-isolated for maximum operator comfort and control. The seat-mounted electro-hydraulic controls provide less vibration for the operator, and they allow combined seat and controls adjustment.

The workstation is spacious, quiet and comfortable, assuring high productivity all day long.

Electro-Hydraulic Implements Controls

The new electro hydraulic implement controls provide the operator with responsive, smooth and precise control of bucket and lift arms. A choice of joystick or two-lever control for bucket lift and dump is available as an option.

Hydrostatic Drive System Controls

This accurate control system allows quick machine travel speed, on-the-go directional changes and counter rotation. A choice of V-lever and joystick for speed and steering control is available through the price list.

Messenger

The 973D comes standard with Cat Messenger, providing real-time machine performance and diagnostic data. Messenger uses a LCD screen to display graphic and text information on machine health, including operating hours, total fuel, fuel consumption rate and total distance. Through Messenger, operator can create his own profile and set Hystat, implement and steering reactions.

Undercarriage

Extended life ... lower owning and operating costs.



Oscillating Undercarriage

The undercarriage on the 973D features an oscillating track roller frame design which decreases ground shock to the machine, increases machine stability, and provides a smoother, more comfortable ride for the operator.

Proven Reliability

Track link design consists of specially heat-treated steel forgings with different degrees of hardness induced into the steel. This feature increases links' life and lowers owning and operating costs. A two-piece master link helps servicing the track chain and reduces down time. All those features help increase loader productivity throughout its life.

Maximize Your Productivity

The standard double grouser shoes are designed for good traction, easy turns and bending. However the 973D is available with several shoes options to best match to the job conditions. Any details count, and a single track shoe can make the difference.



Structures

Tough and durable.

Mainframe and Loader Tower

The D-series Main Frame and Loader Tower are made of single, slab rails with reinforced crossing, with castings and forgings incorporated at points of high stress. This particular design distributes those stresses over wider areas for longer structural life.

Durability Over Years

Structures are designed to provide durability and extended service life to support multiple rebuilds.

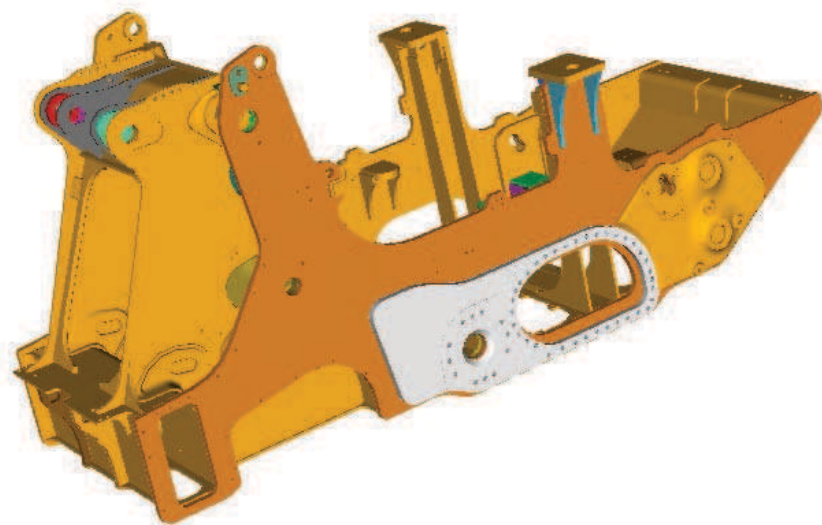



Work Tools

Make more with one machine.

Wide Range of Buckets

The combination of the right bucket with the right machine will provide the best possible performance in your particular application.

The General Purpose (GP) bucket is designed for excellent loadability and long life in applications such as hard bank excavating, stripping, and stockpile loading.

The Multipurpose (MP) bucket is designed for a broad range of applications, such as loading, stripping, clearing, bulldozing, picking up debris, and fine grading. The bucket clamps hydraulically to grip or handle other tough-to-grasp materials.

For special applications, Caterpillar also provides buckets with special features such as Landfill GP/MP Buckets, or Slag Bucket designed to work in the extreme conditions of a steel mill, including moving slag and skulls.

Parallelogram Ripper

The multi shank parallelogram ripper adds extra versatility and force to expand the machine's range of applications. The ripper beam has three pockets for holding ripper shanks, and its design allows the machine to rip frozen ground, asphalt and even hard soils or rock. Longer shanks deliver more work per pass making the machine more productive.

K Series™ Tooth System

The K Series tooth system matches customer expectations for tip retention, easy change-outs and long-term sharpness. The K Series tooth system also features a lower-profile shape that maintains better sharpness as it wears. This means better penetration, improved productivity and less strain on the machine.



The All-Purpose Performer

Unmatched versatility.

General Construction Package

973D is a one-machine workforce that can tackle any task in any jobsite, from general construction to industrial or quarries.

Waste Handling Standard and Extreme Service Packages

On both packages, substantial guarding, debris barriers, cooling system enhancements and precleaners are added to enhance the life and performance of the 973D. The WH standard package should be selected for jobs in landfills, transfer stations or material recovery facilities. The WH ES will be a better fit for transfer stations, demolition sites, severe applications, or when maximum protection is desired.

Steel Mill Package

The steel mill package protects the 973D and its operator against extreme conditions to allow the machine to handle hot slag in steel mill operations. This special package features additional guarding for critical components, sealed undercarriage, heat shields for fuel tank, power train and hydraulics, silicone seals and heat resistant windshield, remote parking brake release and fire-resistant fluids. The Steel Mill Arrangement provides the best protection available for this extremely difficult application.

Wide Gauge Package

The 973D Wide Gauge is designed to work in soft underfoot conditions. The track gauge is widened and wider track shoes installed. A wider bucket also increases productivity, especially in grading and backfilling.

Additional Solutions

Other custom solutions can be designed to address your specific need. Feel free to contact your Cat dealer for more information.

Value Package

Fitted for all earthmoving tasks.

Rear Protection Package

Includes standard rear grill and bumper for general construction.

Rear Protection Heavy Duty Package

Includes heavy duty grill and bumper for restricted working space.

Ripper Package

Includes three curved shanks parallelogram ripper with replaceable tips, and protection grill and steps to climb on the machine by the ripper.

Maintenance Deluxe Package

This package makes easy and allows fast engine oil change. Provide connection for quick evac and fuel sediment flush.

Lights Additional Package

This package includes four more lights guarded.

Protection Windshield and Lights

This package includes a windshield screen and four additional lights.

Striker Bar Package

Striker bar keeps trash from climbing on the tracks and damaging the fender and move back. Also includes steps for a safer access from the rear.

Counterweight Package

Provides counterweight to move back the machine center of gravity and steps for safer Striker bar keeps trash from climbing on the tracks and damaging the fender and move back. Also includes steps for a safer access from the rear.

Contact custom products for waste handling and other specific application requirements.



Serviceability

Designed with safety as the first priority.



Tiltable Cab

This feature makes the maintenance and the repairs easier. By tilting the cab, you can access to the drive train and perform complete service of the hydraulic system.

Standard cab offers 90° tilt capability using an external lifting device while a hydraulic jack is available enabling 30° tilt on the jobsite.

Convenient Service Features

All service points are accessible from ground level on the right side of the engine. Large doors give you an exceptional access to filters and service points. The following features help you to easily service your loader:

- Fuse panel with ET port: Located to the inside of the cab, on the rear right side console, the fuse panel also includes the ET port.
- Gauge control cluster and self-diagnosis Electronic Hydraulic control (EHC): They work together to warn against faults to reduce downtime.
- S•O•SSM Fluid Taps: Simplifies drawing fluid samples for Schedule Oil Sampling and reduces sample contamination.
- Quick-Connect Fittings: The quick-connect hydraulic grouped pressure taps allow quick diagnosis of the hydrostatic drive and the implement hydraulic systems.
- Ground Level Shutdown: Mounted behind a cover at the rear of the machine, a switch allows the machine to be shut down from ground level in emergency situation.

Product Link

Efficient feature to follow and support your machine anywhere.



Product Link

Product Link uses wireless and satellite technology to gather and transmit essential information, related to machine usage, maintenance and location. This information is easily accessible through Equipment Manager.

Product Link is able to:

- Report current equipment parameters (machine hours, location and fuel consumption).
- Show all elements of machine maintenance and keep machine history.
- Predict when a service is needed.
- Alert you to potential and immediate issues.

Benefits to Your Business

- Maximize machine uptime and maintain productivity.
- Simpler, more efficient fleet management.
- Faster service response and quicker resolution time.
- Better maintenance planning.

Your Cat dealer will help you manage your machine maintenance needs identified through equipment monitoring.

Support

Partners in your business.

Your Cat dealer is ready to assist you with your purchase decision and everything after.

- Make comparisons of machines, with estimates of component life, preventative maintenance and cost of production.
- Financing packages are flexible to meet your needs.
- Your Cat dealer can evaluate the cost to repair, rebuild and replace your machine, so you can make the right choice.
- For more information on Cat products, dealer services and industry solutions, visit us at www.cat.com.



Courtesy of Machine.Market

973D Track Loader Specifications

Engine

Engine Model	Cat® C9 ACERT™	
Flywheel Power	196 kW	263 hp
Net Power – Caterpillar	196 kW	263 hp
Net Power – ISO 9249	196 kW	263 hp
Net Power – SAE J1349	196 kW	263 hp
Net Power – EEC 80/1269	196 kW	263 hp
Bore	112 mm	4.41 in
Stroke	149 mm	5.86 in
Displacement	8.8 L	537 in ³

- Engine ratings at 1,900 rpm.
- Meets the U.S. EPA Tier 3, European Union Stage IIIA and Japan MOC exhaust emission regulations.
- Net power advertised is the power available at the flywheel when the engine is equipped with fan, air cleaner, muffler, and alternator.
- No derating required up to 1219 m (3,999 ft) altitude.

Undercarriage

Track Shoe Type	Double Grouser, Extreme Service	
Track Shoe Width – Standard	550 mm	21.6 in
Track Shoe Width – Optional	675 mm	26.6 in
Track Rollers – Each Side	7	
Number of Shoes – Each Side	40	
Track on Ground	2930 mm	115.3 in
Ground Contact Area – Standard Shoe	3.22 m ²	4,991 in ²
Ground Contact Area – Optional Shoe	3.96 m ²	6,138 in ²
Ground Pressure – Standard Shoe	85.5 kPa	12.4 psi
Ground Pressure – Optional Shoe	69.5 kPa	10.1 psi
Grouser Height – Double Grouser	49 mm	1.92 in
Track Gauge	2160 mm	85 in

- Ground pressure is calculated using operating weight of machine with GP bucket, teeth and segments.

Drive System

Type	Hydrostatic drive with infinite machine speeds up to 11 km/h (6.8 mph)	
Drive Pump	Two, variable-displacement, slipper-type axial piston pumps	
Track Motor	Two, variable-displacement, bent axis piston motors	
Max System Pressure	45 000 kPa	6,527 psi

Hydraulic System – Implement

Type	Closed Center Load Sensing	
Output – Maximum	346 L/mn	91.4 gal/mn
Relief Valve Setting	27 500 kPa	3,988 psi
Cycle Time – Raise	6.5 Seconds	
Cycle Time – Dump	1.4 Seconds	
Float Down	2.7 Seconds	

Service Refill Capacities

Fuel Tank	621 L	164 gal
Cooling System	44 L	11.6 gal
Crankcase (with Filter)	29 L	7.7 gal
Final Drives (each)	28.5 L	7.5 gal
Hydraulic system (Equipment, Power Train and Tank)	340 L	89.8 gal
Hydraulic Tank (refill)	189 L	49.9 gal
Pump Drive Box	3.8 L	1 gal
Pivot Shaft	3 L	0.8 gal

Electrical System

Type	24V DC	
Battery Capacity	1400 CCA	
Battery Voltage	12	
Battery Quantity	2	
Alternator	95 amp, Heavy-Duty, Brushless	

Weights

Operating Weight	28 058 kg	61,857 lb
Shipping Weight – without Bucket	25 400 kg	55,997 lb

- Operating Weight: Includes coolant, lubricants, 100% fuel tank, General Purpose Bucket with long bolt-on teeth and segments and 75 kg/165 lb operator.
- Shipping Weight: Includes coolant, lubricants, 10% fuel tank and no bucket.

Buckets

Capacity – General Purpose	3.21 m ³	4.2 yd ³
Capacity – Multi-Purpose	3.05 m ³	3.92 yd ³
Bucket Width – General Purpose	2910 mm	114.56 in
Bucket Width – Multi-Purpose	2868 mm	112.91 in

- Bucket capacities are with long bolt-on teeth and segments.
- Bucket widths are based on a bare bucket.

Operating Specifications

Max. Travel Speed	11 km/h	6.8 mph
-------------------	---------	---------

Ripper Specifications

Type	Parallelogram	
Number of pockets	3	
Overall Width/Beam	2200 mm	86.6 in
Shank cross section	74 × 175 mm 2.9 × 6.9 in	
Ground Clearance	888 mm	34.96 in
Penetration	397 mm	15.6 in
Ripping Width	1840 mm	72.4 in
Penetration Force at ground level	100 kN	22,500 lb
Cylinders – Bore	130 mm	5.1 in
Cylinders – Stroke	236 mm	9.3 in
Addition to Machine Length due to Ripper (in Transportation Position)	586 mm	23.1 in
Ramp Angle	28.5 Degrees	
Ripper weight (with 3 shanks)	1700 kg	3,747.8 lb

Standards

ROPS/FOPS	ROPS/FOPS
Brakes	Brakes
Cab	Cab

- ROPS (Rollover Protective Structure) offered by Caterpillar for the machine meets ROPS criteria SAE J1040 MAY94, ISO 3471-1994.
- FOPS (Falling Object Protective Structure) offered by Caterpillar for the machine meets FOPS criteria SAE J/ISO3449 APR98 level II, ISO 3449-1992 Level II.
- Brakes meet the standard ISO 10265-2008.
- The operator sound exposure Leq (equivalent sound pressure level) measured according to the work cycle procedures specified in ANSI/SAE J1166 OCT 98 is 83 dB(A), for cab offered by Caterpillar, when properly installed and maintained and tested with the doors and windows closed.
- Hearing protection is recommended when operating with open operator station and cab (when not properly maintained or doors/windows open) for extended periods or in noisy environment.
- The exterior sound pressure level for the standard machine measured at a distance of 15 meters (49.2 ft) according to the test procedures specified in SAE J88 APR95, mid-gear-moving operation, is 85 dB(A).
- The labeled sound power level is 112 dB(A) measured according to the test procedure and conditions specified in 2000/14/EC.
- The operator sound exposure Leq (equivalent sound pressure level) measured according to the work cycle procedures specified in ISO 6396:2008 is 77 dB(A) and in ISO 6394:2008 is 74 dB(A), for cab offered by Caterpillar, when properly installed and maintained and tested with the doors and windows closed.

973D Track Loader Specifications

Dimensions

All dimensions are subject to change without notice.

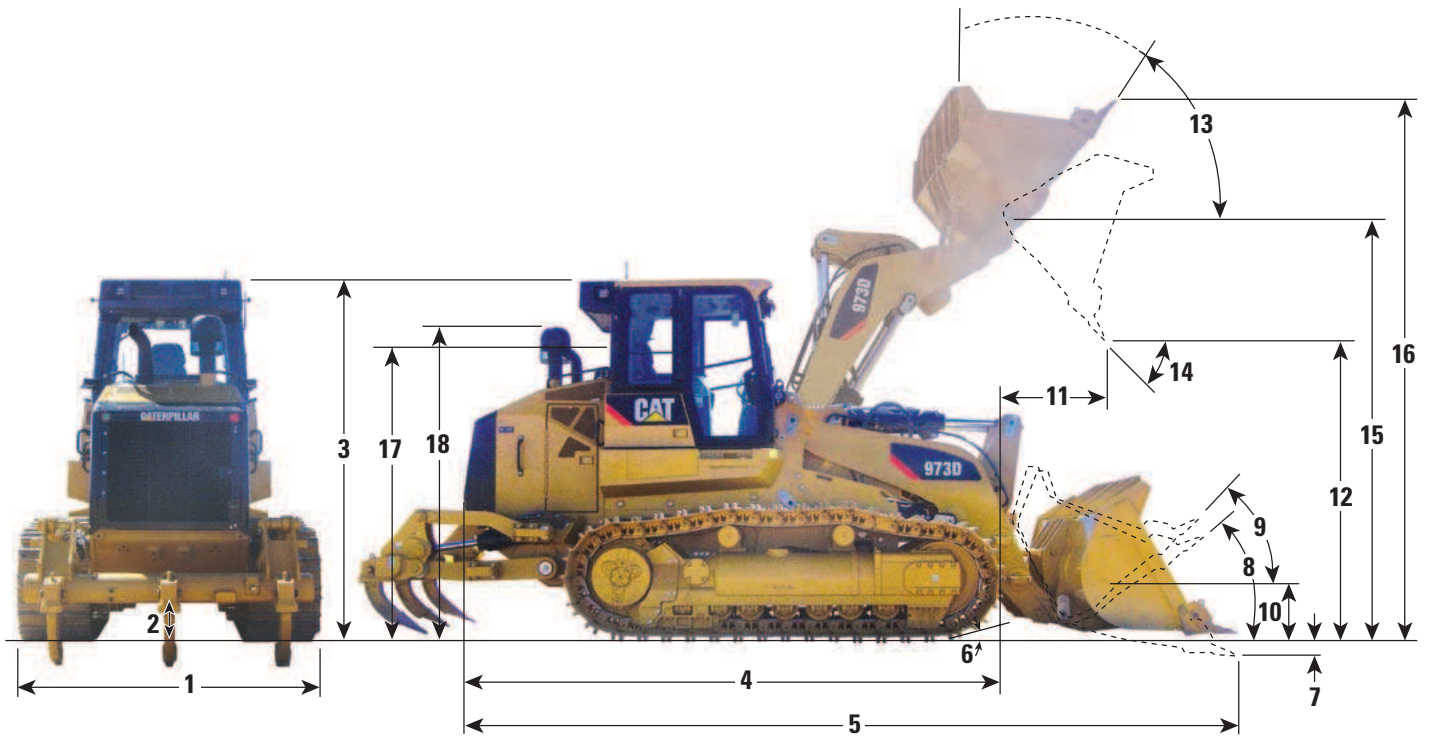

1	Overall machine width without bucket: with tracks – 550 mm (21.6 in shoes) with tracks – 675 mm (26.6 in shoes)	2710 mm 2835 mm	106.7 in 111.6 in
2	Ground clearance	482 mm	19 in
3	Machine height to top of cab	3510 mm	138.2 in
4	Length to front of track	5300 mm	208.6 in
5	Overall machine length*	7305 mm	287.6 in
6	Carry position approach angle	15°	
7	Digging depth*	159 mm	6.25 in
8	Maximum rollback at ground	42°	
9	Maximum rollback at carry position	49°	
10	Bucket height in carry position	483.5 mm	19 in
11	Reach at full lift height and 45° dump*	1473 mm	58 in
12	Clearance at full lift height and 45° dump*	3138 mm	123.5 in
13	Maximum rollback, fully raised	59°	
14	Maximum dump, fully raised Grading angle	59° 85°	
15	Height to bucket hinge pin	4234 mm	166.7 in
16	Overall machine height, bucket fully raised	5651 mm	222.5 in
17	Height to top of the seat with headrest	2975 mm	117.1 in
18	Height to top of the stack	3018 mm	118.8 in

* With general purpose bucket and extra duty teeth.

Dimensions vary with bucket. Refer to Operating Specifications chart.

Operating Specifications

		General Purpose Bucket		Multi Purpose Bucket		Flush Mounted Teeth	
Attachments on bucket cutting edge		None	Long teeth & segments	None	Long teeth & segments	None	Long Teeth
Bucket weight	kg	1716	2090	3083	3453	1810	1875
	lb	3,783.8	4,608.4	6,798.0	7,613.9	3,990.4	4,133.7
Rated load nominal heaped	kg	4919	5521	4730	5246	4919	5521
	lb	10,846.4	12,173.8	10,429.6	11,567.4	10,846.4	12,173.8
Rated capacity nominal heaped (advertised)	m ³	2.86	3.21	2.75	3.05	2.86	3.21
	yd ³	3.7	4.2	3.6	4.0	3.7	4.2
Struck capacity (advertised)	m ³	2.44	2.81	2.33	2.7	2.44	2.81
	yd ³	3.2	3.7	3.1	3.5	3.2	3.7
Bucket width overall	mm	2910	2910	2972	2972	2990	2990
	in	114.6	114.6	117.0	117.0	117.7	117.7
Cutting edge type		None	Straight	None	Straight	—	—
Teeth		None	8 bolt-on with replaceable tips	None	8 bolt-on with replaceable tips	None	8 bolt-on with replaceable tips
Dimensions and weights							
Overall operating height	mm	5765	5765	5918	5918	5765	5765
	in	227.0	227.0	233.0	233.0	227.0	227.0
Clearance at 45° dump maximum lift	mm	3261	3015	3060	2820	3155	3024
	in	128.4	118.7	120.5	111.0	124.2	119.1
Reach at 45° dump maximum lift	mm	1191	1191	1261	1261	1327	1327
	in	46.9	46.9	49.6	49.6	52.2	52.2
Reach at 45° dump 2133 mm (84 in) clearance	mm	1844	1751	1839	1729	1804	1751
	in	72.6	68.9	72.4	68.1	71.0	68.9
Ground Clearance	mm	483	483	483	483	483	483
	in	19.0	19.0	19.0	19.0	19.0	19.0
Overall length – bucket level on the ground	mm	7183	7474	7439	7721	7339	7490
	in	282.8	294.2	292.9	304.0	288.9361	294.881
Digging depth	mm	106	106	199	199	106	106
	in	4.2	4.2	7.8	7.8	4.2	4.2
Full dump at maximum lift	Deg	48	48	48	48	48	48
Carry height	mm	353	353	353	353	353	353
	in	13.9	13.9	13.9	13.9	13.9	13.9
Rackback at carry	Deg	46	46	47	47	46	46
Rackback at ground	Deg	41	41	43	43	41	41
Grading angle	Deg	85	85	85	85	85	85
Rear ramp angle	Deg	29	29	29	29	29	29
Static tipping load min	kg	20 831	21 179	19 810	19 455	—	21 006
	lb	45,932.4	46,699.7	43,681.1	42,898.3	—	46,318.2
Breakout with cylinders level at ground	N	281 887	220 224	236 920	193 125	—	—
	lbf	63,424.6	49,550.4	53,307.0	43,453.1	—	—
Lift capacity to full lift – bucket racked	kg	16 066	15 564	14 656	14 134	—	—
	lb	35,425.5	34,318.6	32,316.5	31,165.5	—	—
Lift capacity at ground line – bucket racked	kg	29 049	28 555	27 631	27 120	—	—
	lb	64,053	62,963.8	60,926.4	59,799.6	—	—
Shipping weight without bucket	kg	25 400	25 400	25 484	25 484	25 400	25 400
	lb	59,973.1	59,973.1	56,182.5	56,182.5	55,997.4	55,997.4
Operating weight with bucket	kg	27 699	28 058	29 194	29 553	27 758	27 824
	lb	61,065.8	61,857.2	64,361.7	65,153.1	61,195.8	61,195.8

973D Standard Equipment

Standard equipment may vary. Consult your Cat dealer for details.

ELECTRICAL

Alternator, 95 amps, 24 V, heavy duty brushless
Alarm, backup
Horn, electric
2 Maintenance free batteries, 1,400 amps
Converter 24V/12V
Switch, main disconnect
Starter, electric (24V)
Four halogen lights, two forward facing, roof mounted; two rearward facing, integrated in A/C unit

OPERATOR ENVIRONMENT

Pressurized, sound suppressed, ROPS/FOPS cab
Cab with tinted glass and side sliding window
Air conditioning and heating
Heater, defroster with automatic temperature control
Seat, fabric-covered, air suspended
Seat-mounted controls
Seat belt, retractable
Electronic Monitoring System
Gauges for:
• Engine coolant temperature
• Engine oil pressure
• Hydraulic oil temperature
• Fuel level
Electro-hydraulic implement control joystick

Radio ready, includes 24 to 12V converter, speakers, antenna and two 12 volts power outlets
Mirror rearview
Coat Hook
Adjustable armrest
Transmission control, Joystick or V-lever and steering pedals
Storage lockable compartment under armrests
Floor mat, rubber, heavy duty
Windshield washers and wipers, front and rear
Durable metal roof
Parking brake switch and “brake-on” indicator light

POWER TRAIN

Caterpillar C9 ACERT diesel engine
Modular cooling system for engine air intake, oil and water
24 volt electric starting
Electronically controlled, on-demand fan cooling system
Extended Life Coolant
Fuel priming pump electric
Electronic Hydrostatic Control (EHC) for transmission with travel and work modes
Closed Loop Hystat transmission with DSR Software
Muffler, under hood
Water separator

UNDERCARRIAGE

2160 mm/85 in track gauge
End Section Track Guiding guards
Hydraulic Track Adjuster
EWL track (40 sections, 215 mm /8.5 in pitch)
Five piece sprocket track
Seven track rollers, lifetime lubricated
Conventional idlers, lifetime lubricated.
Oscillating track roller frames
Two carrier rollers per track
Track Master Link
Guard, idler

OTHER STANDARD EQUIPMENT

Sound Suppression, Exterior
Z-bar loader linkage
Load sensing variable displacement implement pump
Implement cylinders with integrated positioning sensors
Operator programmable lift and tilt kickouts
Engine enclosure with lockable doors (5 mm/0.2 in perforated holes)
Hinged radiator grill
6.35 fins per inch radiator and cooler cores
Ecology Drains
Hydraulic Oil, HYDO Advanced 10
Cab, tilt jack, hydraulic

Optional equipment may vary. Consult your Cat dealer for details.

ELECTRICAL

Beacon, rotating

POWER TRAIN

Tank fuel, fast fill

HYDRAULIC

Hydraulic oil, biodegradable

BUCKET

General Purpose, Slag

BUCKET ATTACHMENTS

Teeth, extra duty, 8

Teeth, penetration, 8

Cutting edge, bolt-on

UNDERCARRIAGE

Track, 500 mm (19.7 in), flat

Track, 500 mm (19.7 in), alternates flat and DG GR shoes

Track, 675 mm (26.6 in), Trap Hole

DBL GR

Track, 500 mm (19.7 in)

Track, 550 mm (21.6 in)

Track, 675 mm (26.6 in)

Track, 830 mm (32.7 in)

Track, 500 mm (19.7 in), Trap Hole

Track, 675 mm (26.6 in), Trap Hole

TRPL GR

Track, 500 mm (19.7 in)

SGL GR ES

Tracks, 500 mm (19.7 in), Trap Hole

GUARDS

Guard, tilt cylinders

Guard, track roller

OTHER ATTACHMENTS

Radio AM/FM, CD

Heater, engine coolant, 120V

Heater, engine coolant, 240V

Product Link

Machine Security System

Antifreeze, -50° C (-58° F)

973D VALUE PACKAGES

Rear protection STD

Rear protection HD

Ripper package

Maintenance package, deluxe

Lights additional, package

Protection, windshield, lights

Striker bar package

Counterweight package

Hydraulic 2W, Joystick

Hydraulic 3W, MP Joystick

Hydraulic 3W, GP Joystick

Hydraulic 4W, MP joystick

Hydraulic, 2W, 2 levers

Bucket GP, 3.0 m³ (3.98 yd³), package

Bucket MP, 2.8 m³ (3.6 yd³), package

Bucket GP, 3.0 m³ (3.98 yd³), package

Bucket GP, landfill, package

Bucket wide, 3.3 m³ (4.37 yd³), package

Bucket GP, 3.0 m³ (3.98 yd³), HD, pack

Bucket MP ES, 2.8 m³ (3.6 yd³), package

Bucket MP, landfill, package

973D Track Loader

For more complete information on Cat products, dealer services, and industry solutions, visit us on the web at www.cat.com

© 2010 Caterpillar Inc.
All rights reserved

Materials and specifications are subject to change without notice. Featured machines in photos may include additional equipment. See your Caterpillar dealer for available options.

CAT, CATERPILLAR, SAFETY.CAT.COM, their respective logos, "Caterpillar Yellow" and the "Power Edge" trade dress, as well as corporate and product identity used herein, are trademarks of Caterpillar and may not be used without permission.

AEHQ5970-02 (01-2010)

Replaces AEHQ5970-01

CATERPILLAR[®]

Courtesy of Machine.Market