

973D

Waste Handler



Engine

Engine Model	Cat® C9 ACERT™	
Net Power – SAE J1349	196 kW	263 hp

Weights

Operating Weight	29 555 kg	65,157 lb
------------------	-----------	-----------

Buckets

Capacity		
General Purpose Landfill	4.9 m ³	6.4 yd ³
Multi-Purpose Landfill	4.6 m ³	6.0 yd ³

973D Waste Handler Features

Track-Type Loader Versatility

If you need a machine that can . . . Doze, Compact, Shred, Rip, Spread, Sort, Dig, Load Trucks – The new 973D waste handler can do it all.

Waste Protection – Reliability

The 973D WH offers field proven components and systems, high hour machine life standards and multiple rebuild options for continued uptime and long machine life.

Performance

Powered by the proven Cat C9 engine with ACERT Technology, the 973D has new levels of power for getting work done.

Serviceability

Designed to ensure minimal downtime with attention to ground level access and grouped service points, the 973D maximizes production and minimizes service time.

Comfort and Safety

The 973D WH offers a number of features that optimize visibility and sound levels, allow for safe machine service and enhance operator health and well-being.

Sustainability

Rebuild it with remanufactured parts or recycle the steel when the time comes. The 973D is governed to use only the fuel required to meet load demand, and with ACERT Technology onboard, is Tier 3/ Stage IIIA emissions friendly.



Contents

Value for your Investment	3
Waste Handler Guarding	4
Prevention	6
Track Shoe Options.....	7
Operator Environment.....	8
Cat Work Tools.....	9
Operation and Service	10
Customer Support.....	11
Sustainability	12
973D Waste Handler Specifications	13

Caterpillar built its first track loader in 1955. With its pedigree for digging, the track loader has excavated millions of building foundations all over the globe. It wasn't long before customers demanded that the strength and versatility of this machine be adapted to the forestry, demolition, steel mill and waste industries.

With Caterpillar built and designed waste handling features, the track loader is now considered the second most useful machines in a landfill (after the compactor).

The Cat® 973D is the largest, most powerful track loader in the world, and it's the safest, most environmentally friendly and efficient track loader Caterpillar has ever built. Put it to work in waste, it's designed for it. Read on for more information on the 973D's waste handling attributes, and how they can benefit your operation.



Value for your Investment

This machine will exceed your expectations

- **Versatility** – With the right work tool, the 973D has extreme versatility. It can sort waste, maintain haul roads, dig large quantities of dirt, then finely spread cover material. With a trash rack installed, it can doze large volumes of waste. Add a ripper to assist with haul road maintenance and loosen cover material. With its z-bar linkage, the 973D is a world class digging machine. It also excels at truck loading, feeding hoppers and maintaining dump areas and haul roads. With hystat drive and a new transmission joystick control, the machine is easy to run, highly maneuverable, quick to accelerate and can turn in extremely tight spaces.
- **Uptime** – With valuable input from our customers and Dealers, Caterpillar has been designing waste handling machines for decades. Our proven designs keep the machines running for thousands of reliable hours each year. The 973D takes machine availability to a higher level with the benefit of traction in bad weather. The 973D can keep trucks moving; work in sloppy underfoot conditions and keep the landfill operational. With its stability, it can work comfortably in loose waste, demolition debris or wet clay.
- **Machine Productivity** – Quick, maneuverable, and highly productive with simple to use, intuitive controls and bucket options to match production requirements. (See bucket details on page 9.)
- **Waste Handling Packages** – For your convenience, Caterpillar offers two waste handling guarding packages.
 - Waste Handler – designed for landfills, transfer stations and material recovery facilities
 - Waste Handler Extreme Service – intended for demanding demolition work and maximum protection
- **Safety** – Safety is paramount around people, equipment and waste. The 973D helps protect the operator with a front windshield screen, fresh, clean air inside the cab, and three points of contact when getting on and off the machine. For those working around the machine, the 973D WH will sound a back up alarm when reversing, the operator has improved visibility around the machine from the new cab and sloped hood design, and all daily inspection points can be viewed from ground level.

Waste Handler Guarding

Long-term protection for your machine and business

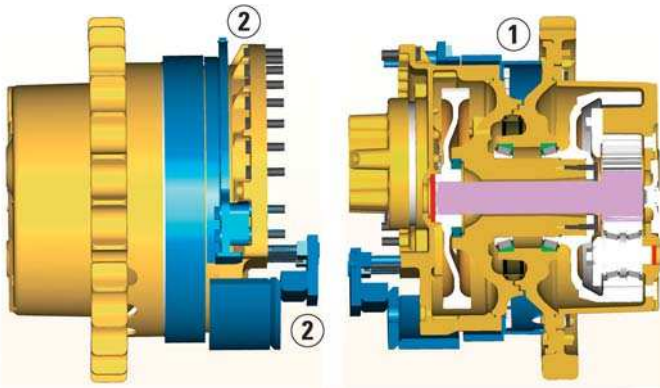

Seal Protection Guard Group

- Seals are a critical design element for protecting gears and lubricant fluids. In waste applications, these seals require additional protection against wire, nylon straps and other debris. The 973D WH has guarding for final drive, pivot shaft and idler seals.
- Heavy-Duty Final Drive Seal Guards prevent damage to Final Drive Duo-cone Seals by preventing wire, plastics and other debris from wrapping. (1)

Final Drive Abrasion Guards (2)

Final drive guarding protects two ways, first against debris impact loads and secondly from abrasive materials like waste and demolition materials. These drives are manufactured with an abrasion resistant steel for long life.

Front Idler Guard (3)

A front idler guard blocks material from affecting the yoke, link, recoil rod and idler in the drive train.

Lift Cylinder Lines and Position Sensor Guard (4)

Protects the lift cylinder, hydraulic lines and position sensor harness from mud and waste.

Heavy-Duty Hydraulic Tank Guard (5)

Deflects debris away from the hydraulic tank.

Fender Reinforcement

- Reinforced fenders protect cab and sheet metal by blocking and deflecting debris with a angled design. (6)
- A tapered front deflector pushes debris out and away from the machine when backing up.

Oil Gauge Guard (7)

Act as a debris barrier that prevents oil gauge damage and debris entry in the engine compartment.

Third Valve Lines Guards (not shown)

Protect steel hydraulic lines for Multi-Purpose Bucket from damage caused by material pushed upward between lift arms when back-dragging. The guards are located at the inner side of the lift arm.

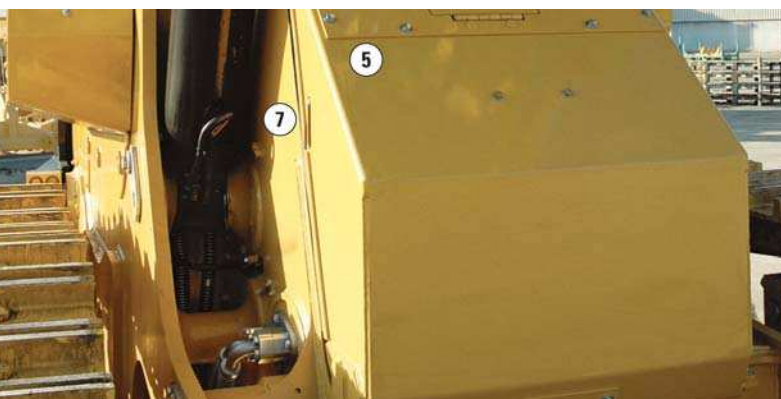
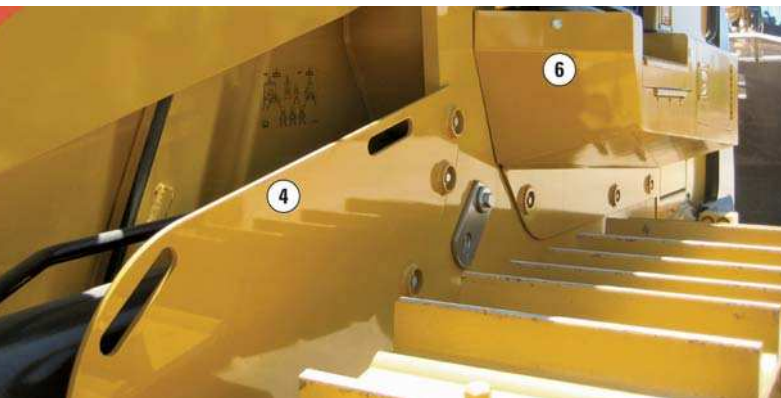



Waste Handler Guarding (cont.)

Heavy-Duty Bumper

- Protects the radiator and adds rigidity and strength to surrounding structures against debris.
- Designed to maintain excellent visibility to the rear.
- Includes heavy-duty hinged grill that protects the radiator. Easy to open and clean.
- Built strong to include a hitch point for pulling trucks or other equipment.

Rear Striker Bar

Designed to prevent large debris from riding up the track and damaging the machine. Also serves as a step for entering the cab.

Tilt Cylinder Guards

- Protect cylinder, cylinder rod and hydraulic lines from falling debris.
- Help extend cylinder seal life.

Heavy-Duty Swing Open Bottom Guards

- Help protect engine and drive train from damage.
- Hinged to provide easy access for servicing and cleanout.

Prevention

Designs to keep you running



While guarding will protect most of the machine from impact loads, additional protection is needed to keep smaller particles from clogging air circulation around and to the engine. Following are additional waste handling features that are important to machine uptime.

Windshield Screen

Designed to keep the operator safe from debris that could break the windshield. It's hinged to allow easy access to the glass for cleaning.

Debris Barrier Package

- A complete set of rubber baffles and seals safeguard the engine and power train compartment against build-up of debris and cooling package against plugging. This results in longer operating time between cleanouts, maximized machine uptime and reduced operating costs. Barriers are present at interfaces between the cab, chassis, fenders and engine enclosure doors.
- The cooling package requires air free of flying debris for optimum performance. In order to reduce debris entry and encourage air flow, 5 mm (0.2 in) diameter perforations are designed into hood and engine enclosure doors.

Prevention (cont.)



Precleaner with Prescreener

- Essential to all waste handlers, the precleaner with a prescreener attached prevents trash from entering the engine air intake.
- Integral to the system is a turbine-type dust ejection system that extends filter life.

Debris-Resistant Air Conditioner Condenser

- The air conditioning system is designed so that the air inlet is protected from falling debris.
- Provides excellent visibility to the rear of the machine.

Louvered Rear Grill

This grill is designed with louvers angled at 45° to deflect debris.

Trash Resistant Radiator and Coolers

Providing space between radiator fins allows smaller debris to pass through. This promotes better cooling performance and reduces the number of cleanouts. The 973D is equipped with a 6 fpi radiator and coolers.

On-Demand Fan

This feature reduces cooling package plugging, enhances cold weather operation, improves fuel economy and reduces exterior noise. In the waste handling applications, a lower air flow reduces the amount of garbage collected on air inlets which increases the maintenance interval.



Track Shoe Options

Double Grouser Track

- Provides good balance and traction with a smooth ride.
- Available with a trapezoidal center hole that resists track packing and track chain tightening.

Single Grouser Track

- Aggressive track for good chopping action in debris.
- Offers the best traction in poor underfoot conditions.
- Available with trapezoidal center hole that resists track packing and track chain tightening.



Operator Environment

Promoting safe, engaged, and productive operators

The 973D has a new cab that promotes comfort and focus on the job. Operators enjoy greater visibility around the machine fostering greater confidence and safety.

Safety

- ROPS/FOPS operator protection – integral to the cab structure.
- Greater glass throughout improves visibility around the machine.
- Sound reduction – the 973D has exceptional noise reduction in the cab, lowering operator dynamic noise to 77 dB(A) per ISO 6396. This reduces fatigue and promotes greater focus on the job.
- Rubber isolation mounts – dampen vibration transmitted from the machine into the cab for comfort and focus.
- Automatic temperature control and filtered air – is pressurized to keep dust out, and allows the operator to set cab air temperature to their preferred level.
- Heavy-duty hinged windshield screen – protects the operator from debris capable of breaking glass. Convenient to open when cleaning the windshield.
- A three-point seat belt is retractable (keeping it clean) and 75 mm (3 in) wide for comfortable restraint.
- Excellent coverage to the work area can be extended with an optional lighting adding illumination forward and to the rear.

Convenience

- Optional transmission joystick (see bottom RHS picture) offers low effort control of machine direction. Two joystick transmission control patterns are available to suit operator preference.
- The air suspension seat includes a removable headrest, lumbar adjustment and a rear seat document holder for the OMM.
- The seat and its armrests are fully adjustable allowing the operator to customize their operation of the machine.
- Power train controls on the left side will tilt for quick and easy access into the cab seat.

Cat Work Tools

Options that make the most of the 973D's strengths

For the greatest return on your investment, your 973D should be equipped specifically for the demands of your job site. The 973D comes with two bucket options, trash rack options and a ripper. Choosing the right bucket will make the most of the machine's versatility. Both buckets offer long life and durability in waste applications.



- **General Purpose Landfill bucket** – has a capacity of 4.9 m³ (6.4 yd³) and can be equipped with an optional trash rack for dozing lightweight materials. This bucket is designed for easy loading in stockpile or hard bank materials. Adding the trash rack helps prevent material from spilling over the top and increases dozing capacity by 52%.

- **Multi Purpose Landfill bucket** – has a capacity of 4.6 m³ (6.0 yd³) and can greatly expand the 973D's versatility. It can act as a typical bucket for loading trucks, dozing waste or digging. It can also instantly change into a dozer-type blade for spreading cover material, or it can sort material with the ability to clamp on to debris. By adding the trash rack to this bucket, its capacity to doze and load material increased 53%.



- **Ripper** – A 3-shank parallelogram ripper facilitates working in frozen ground and hard materials like asphalt, rocky ground and hard clay. Ripper shank options are available to help improve ripping productivity.



- **K Series™ Tooth System** – offers options that match the requirement of your job site. The system is easy to change, stays secure on the bucket, and offers long term sharpness.



Operation and Service

Service convenience and operator efficiency by design

Fast Fill Fuel System

In high-hour applications, pausing to fuel can be a drain on productivity. The 973D's fast fill system is capable of adding fuel at 568 L/min (150 gal/min).

Counterweight Package

Machine balance is critical in poor underfoot conditions, load and carry and truck loading applications. Caterpillar offers a counterweight package that provides 1460 kg (3,218 lb) to the rear of the machine. Counterweight is ideal for machines not equipped with a ripper.

Windshield Sealed

The front windshield is sealed to ease replacement in the field and maximize uptime.

Electronic Monitoring System

This system identifies the specific machine issue, displays the fault and facilitates quick resolution by service personnel.

Product Link Enabled

This option can keep vital personnel in contact with the machine, its performance including fuel use, its parts and service needs and out of spec operation or locations. Service is more efficient with advance notice of required parts, and timing can be arranged per your schedule.

Tilttable Cab

This feature allows service personnel to access important drive train and hydraulic components. The cab can tilt 30 degrees in the field with the aid of a hydraulic jack or tilt 90 degrees using an external lifting device.

Maintenance Package Deluxe

Choosing this option when purchasing the machine will add the convenience of quick evacuation for engine oil and sediment flushing of the fuel tank.

Customer Support

Caterpillar has the most experienced dealer network in the world

Commitment Makes the Difference

Cat dealers offer a wide range of solutions, services and products to help you lower costs, enhance productivity and manage your operation more efficiently. From the time you select a piece of Cat equipment until you trade or sell it, the support you get from your Cat dealer makes the difference.

Dealer Capability

Cat dealers provide the level of support you need on a global scale. Dealer expert technicians have the knowledge, experience, training and tooling necessary to handle your repair and maintenance needs, when and where you need them.

Product Support

When Cat products reach the field, they are supported by a worldwide network of parts distribution facilities, dealer service centers and technical training facilities to keep your equipment up and running. Cat customers rely on prompt, dependable parts availability through our global dealer network, meeting your needs 24/7.

Service Support

Cat equipment is designed and built to provide maximum productivity and operating economy throughout its working life. Cat dealers offer a wide range of service plans that will maximize uptime and return on your investment, including:

- Preventive Maintenance Programs
- Diagnostic Programs, such as Scheduled Oil Sampling and Technical Analysis
- Rebuild and Reman Options
- Customer Support Agreements

Application Awareness

Operating and maintenance costs are influenced by many application and site-specific factors, such as: material density, loading position, payload, grades, speeds, haul road design and maintenance. Your Cat dealer can provide you with an understanding of the effects application characteristics and operating techniques have on maintenance and operating costs.

Operation

Your Cat dealer offers training programs to help operators improve productivity, decrease downtime, reduce operating costs and enhance safety.

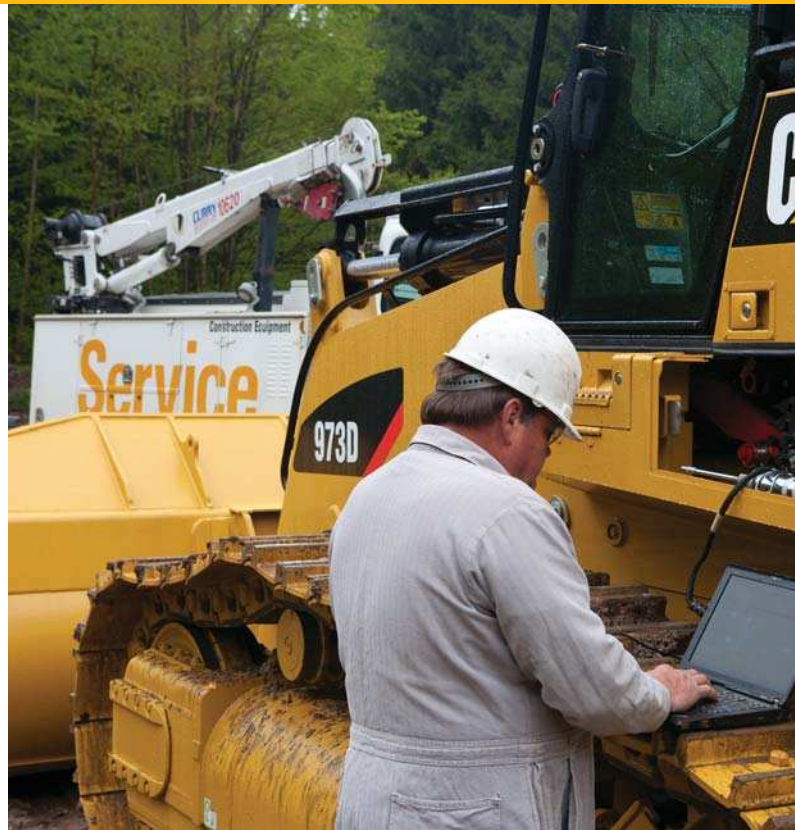



Sustainability

A commitment for future generations

Caterpillar is committed to building safe products that contribute to your business, promote efficient energy use and help protect the environment.

Greenhouse Gas Emissions

The 973D is a Tier 3/Stage IIIA emissions compliant machine with reduced levels of carbon dioxide and soot.

Sound

The 973D has reduced noise levels of 77 dB(A) dynamic with noise reduction technology throughout the cab.

Fuel Efficiency

- Cooler environments will see a fuel benefit from the on-demand cooling fan that uses energy only when it's needed.
- Electronic governing and the fine, accurate injection of fuel make the Cat C9 engine responsive to load yet mindful of fuel use.

Life Cycle Costs

Caterpillar and your Dealer can offer you remanufactured parts, customer service agreements and rebuild options. The machine is designed to limit downtime with 500 hour oil and filter changes, waste specific guarding and protection, and quick evacuation of engine oil and hydraulic oil. Scheduled oil sampling can monitor the health of your machine. Parts commonality with other Cat equipment reduces parts stocking requirements at either your shop or the Dealer's.

Recycle

When the time comes, all of the steel that makes up the 973D Waste Handler can be recycled and reused.

Engine

Engine Model	Cat® C9 ACERT™	
Net Power – SAE J1349	196 kW	263 hp
Bore	112 mm	4.41 in
Stroke	149 mm	5.86 in
Displacement	8.8 L	537 in ³

- Engine ratings at 1,900 rpm.
- Meets the U.S. EPA Tier 3, European Union Stage IIIA and Japan MOC exhaust emission regulations.
- Net power advertised is the power available at the flywheel when the engine is equipped with fan, air cleaner, muffler, and alternator.
- No derating required up to 1219 m (3,999 ft) altitude.

Undercarriage

Track Shoe Type	Double Grouser, Extreme Service	
Track Shoe Width – Standard	550 mm	21.6 in
Track Shoe Width – Optional	675 mm	26.6 in
Track Rollers – Each Side	7	
Ground Pressure – Standard Shoe	85.5 kPa	12.4 psi
Ground Pressure – Optional Shoe	69.5 kPa	10.1 psi
Grouser Height – Double Grouser	49 mm	1.92 in
Track Gauge	2160 mm	85 in

- Ground pressure is calculated using operating weight of machine with GP bucket, teeth and segments.

Drive System

Type	Hydrostatic drive with infinite machine speeds up to 11 km/h (6.8 mph)	
Drive Pump	Two, variable-displacement, slipper-type axial piston pumps	
Track Motor	Two, variable-displacement, bent axis piston motors	
Maximum System Pressure	45 000 kPa	6,527 psi

Hydraulic System – Implement

Type	Closed Center Load Sensing	
Output – Maximum	346 L/min	91.4 gal/min
Relief Valve Setting	27 500 kPa	3,988 psi
Cycle Time – Raise	6.5 Seconds	
Cycle Time – Dump	1.4 Seconds	
Float Down	2.7 Seconds	

Service Refill Capacities

Fuel Tank	621 L	164 gal
Cooling System	44 L	11.6 gal
Hydraulic System (Equipment, Power Train and Tank)	340 L	89.8 gal
Hydraulic Tank	189 L	49.9 gal

Electrical System

Type	24V DC	
Battery Capacity	1400 CCA	
Battery Voltage	12	
Battery Quantity	2	
Alternator	95 amp, Heavy-Duty, Brushless	

Weights

Operating Weight	29 555 kg	65,157 lb
Shipping Weight – without Bucket	29 430 kg	64,882 lb

- Operating Weight: Includes coolant, lubricants, 100% fuel tank, General Purpose Bucket with long bolt-on teeth and segments and 75 kg (165 lb) operator.
- Shipping Weight: Includes coolant, lubricants, 10% fuel tank and no bucket.

Buckets

Capacity		
General Purpose	3.21 m ³	4.2 yd ³
General Purpose Landfill	4.9 m ³	6.4 yd ³
Multi-Purpose	3.05 m ³	3.92 yd ³
Multi-Purpose Landfill	4.6 m ³	6.0 yd ³
Width		
General Purpose	2910 mm	114.56 in
General Purpose Landfill	2910 mm	114.56 in
Multi-Purpose	2868 mm	112.91 in
Multi-Purpose Landfill	2868 mm	112.91 in

- Bucket capacities are with long bolt-on teeth and segments.
- Bucket widths are based on a bare bucket.

Ripper Specifications

Type	Parallelogram	
Number of Pockets	3	
Overall Width/Beam	2200 mm	86.6 in
Ground Clearance	888 mm	34.96 in
Penetration	397 mm	15.6 in
Ripping Width	1840 mm	72.4 in
Penetration Force at Ground Level	100 kN	22,500 lb
Addition to Machine Length (in Transportation Position)	586 mm	23.1 in
Ramp Angle	28.5 Degrees	
Ripper Weight (with 3 shanks)	1700 kg	3,747.8 lb

Standards

- ROPS (Rollover Protective Structure) offered by Caterpillar for the machine meets ROPS criteria SAE J1040 MAY94, ISO 3471-1994.
- FOPS (Falling Object Protective Structure) offered by Caterpillar for the machine meets FOPS criteria SAE J/ISO 3449 APR98 Level II, ISO 3449-1992 Level II.
- Brakes meet the standard ISO I0265-2008.
- The operator sound exposure Leq (equivalent sound pressure level) measured according to the work cycle procedures specified in ISO 6396:2008 is 77 dB(A), in ISO 6394:2008 is 74 dB(A) and in ANSI/SAE J1166 OCT98 is 83 dB(A), for cab offered by Caterpillar, when properly installed and maintained and tested with the doors and windows closed.
- Hearing protection is recommended when operating with open operator station and cab (when not properly maintained or doors/windows open) for extended periods or in noisy environment.
- The exterior sound pressure level for the standard machine measured at a distance of 15 meters (49.2 ft) according to the test procedures specified in SAE J88 APR95, mid-gear-moving operation, is 85 dB(A).
- The labeled sound power level is 112 dB(A) measured according to the test procedure and conditions specified in 2000/14/EC.

973D Waste Handler Specifications

Dimensions

All dimensions are subject to change without notice.

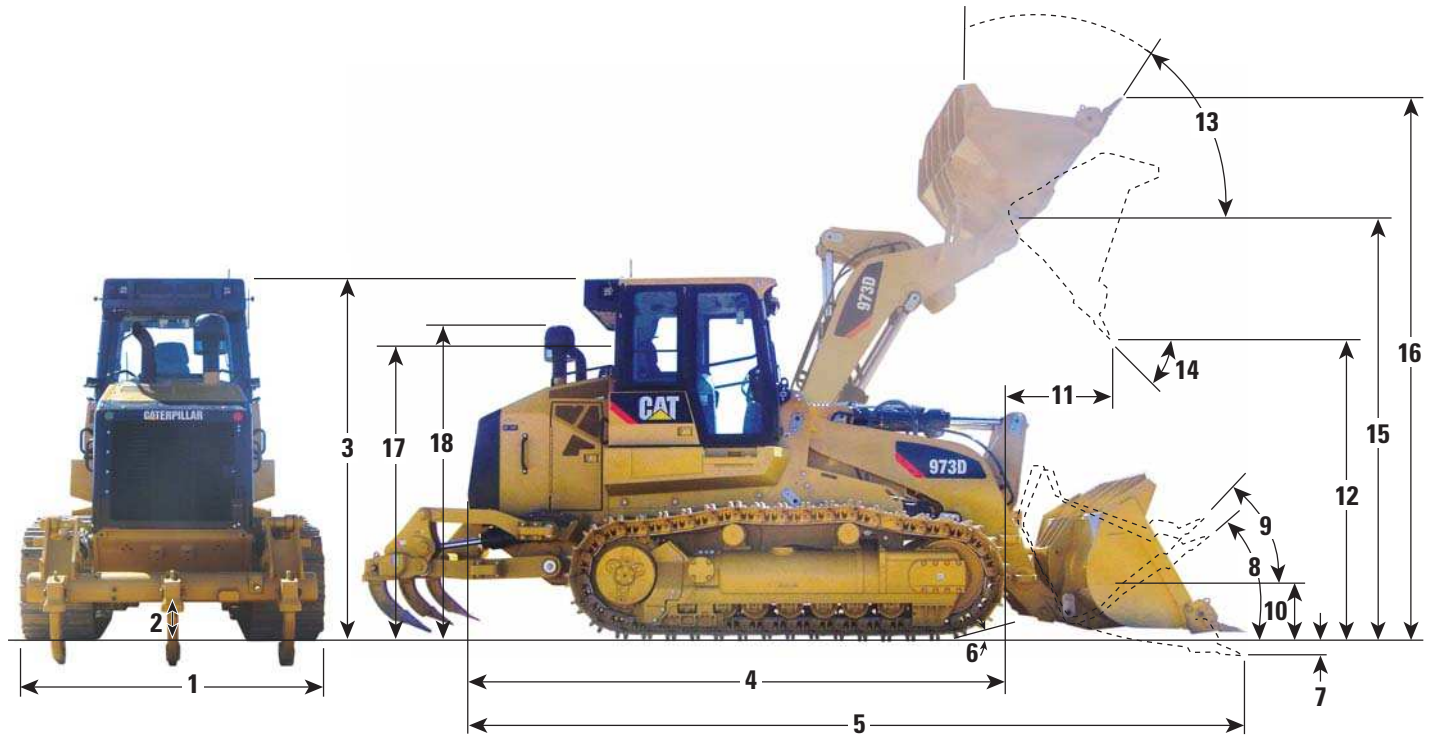

1 Overall Machine Width without Bucket:		
with Tracks – 550 mm (21.6 in shoes)	2710 mm	106.7 in
with Tracks – 675 mm (26.6 in shoes)	2835 mm	111.6 in
2 Ground Clearance	482 mm	19 in
3 Machine Height to Top of Cab	3510 mm	138.2 in
4 Length to Front of Track	5300 mm	208.6 in
5 Overall Machine Length*	7305 mm	287.6 in
6 Carry Position Approach Angle		15°
7 Digging Depth*	159 mm	6.25 in
8 Maximum Rollback at Ground		42°
9 Maximum Rollback at Carry Position		49°
10 Bucket Height in Carry Position	483.5 mm	19 in
11 Reach at Full Lift Height and 45° Dump*	1473 mm	58 in
12 Clearance at Full Lift Height and 45° Dump*	3138 mm	123.5 in
13 Maximum Rollback, Fully Raised		59°
14 Maximum Dump, Fully Raised		59°
Grading Angle		85°
15 Height to Bucket Hinge Pin	4234 mm	166.7 in
16 Overall Machine Height, Bucket Fully Raised	5651 mm	222.5 in
17 Height to Top of the Seat with Headrest	2975 mm	117.1 in
18 Height to Top of the Stack	3018 mm	118.8 in

* With general purpose bucket and extra duty teeth.

Dimensions vary with bucket. Refer to Operating Specifications chart.

Features

	D Series Application Packages		
	Construction	Waste	Waste ES
Cast Stellite Duo-Cone® Seals	X	X	X
Final Drive Seal Guards	X	X	X
Heavy-Duty Final Drive Seal Guards		X	X
Pivot Shaft Seal Guards	X	X	X
Final Drive Abrasion Guards for Bottom Bolts	N/A	X	N/A
Final Drive Abrasion Guards for Top and Bottom Bolts	N/A	N/A	X
Idler Seal Guards	X	X	X
Front Idler Guard	X	X	X
Lift Cylinder Lines and Position Sensor Guard	X	X	X
Heavy-Duty Hydraulic Tank Guard (at front)	X	X	X
Guard Oil Gauge	N/A	X	X
Heavy-Duty Fender with Deflector and Battery Box	X	X	X
Rear Protection Heavy-Duty; Bumper and Grill	O	N/A	R
Rear Striker Bars	O	O	X
Heavy-Duty Swing Open Bottom Guards	X	X	X
Tilt Cylinder Rod Guards	O	O	X
Multi-Purpose Bucket Line Guards	O	O	O
Track Roller Guards	O	O	O
Front Light Guards	O	O	O
Track Groups with Center Holes	O	O	O
Cat Turbine Air Precleaner	O	X	X
Swing-Out Radiator Grill	X	X	X
Trash Resistant Radiator	X	X	X
Variable Speed Fan (demand fan)	X	X	X
Screened Hood	X	X	X
Debris Barrier Package	X	X	X
Front Windshield Sealed	X	X	X
Heavy-Duty Hinged Windshield Screen with Latch	O	O	O
Four Halogen Lights, Two Facing Forward, Roof Mounted; Two Facing Rearward; Integrated in Air Conditioning Unit	X	X	X
Four Additional Lights, Two Facing Frontward and Two Facing Sideways	O	O	O
Maintenance Package Deluxe (engine oil quick evac)	O	O	O
Fuel Tank Fast Fill	O	O	O
Counterweight	O	O	N/A
General Purpose Bucket with Trash Rack	O	O	O
Multi-Purpose Bucket with Trash Rack	O	O	O
Parallelogram Ripper	O	O	O
Hydraulic Oil Bio	O	O	O
Beacon Rotating	O	O	O

X: Feature present either inside the package or in the base machine

R: Feature required by the package

O: Option

N/A: Not Available

973D Waste Handler

For more complete information on Cat products, dealer services, and industry solutions, visit us on the web at www.cat.com

© 2010 Caterpillar Inc.
All rights reserved

AEHQ6137 (08-2010)

Materials and specifications are subject to change without notice. Featured machines in photos may include additional equipment. See your Cat dealer for available options.

CAT, CATERPILLAR, SAFETY.CAT.COM, their respective logos, "Caterpillar Yellow" and the "Power Edge" trade dress, as well as corporate and product identity used herein, are trademarks of Caterpillar and may not be used without permission.

