

980H

Wheel Loader



Engine

Engine Model	Cat® C15 ACERT™	
Gross Power – SAE J1995	293 kW	393 hp
Net Power – ISO 9249	260 kW	349 hp

- Caterpillar® engine with ACERT Technology – EPA Tier 3, EU Stage III Compliant

Buckets

Bucket Capacities	3.8-6.1 m ³	5.0-8.0 yd ³
-------------------	------------------------	-------------------------

Weights

Operating Weight	30 519 kg	67,294 lb
------------------	-----------	-----------

- For 5.7 m³ (7.5 yd³) general purpose bucket with BOCE

Operating Specifications

Static Tipping Load, Full Turn	19 496 kg	42,989 lb
--------------------------------	-----------	-----------

- For 5.7 m³ (7.5 yd³) general purpose bucket with BOCE

980H Wheel Loader

The new standard for midsize wheel loaders.

Reliability

- Proven Technologies
- Dealer Support You Can Count On
- Unmatched Parts Availability
- Extensive Rebuild Program
- Exceptional Service Capabilities **pg. 4**

Durability

- Structures Built To Last
- Proven Planetary Transmission
- C15 Engine With ACERT™ Technology
- Integrated Systems **pg. 6**

Productivity

- Consistent Level Of Power
- Standard And Optional Features To Increase Productivity **pg. 8**

Serviceability

- Simple, Easy Daily Maintenance
- Minimal Downtime For Service
- Detect Problems Before They Happen
- Complete Customer Support **pg. 16**

Performance you can feel with the capability to work in the most demanding applications. Unmatched operator comfort and efficiency in a world class cab. Revolutionary electronics and hydraulics for low-effort operation. Increased productivity with lower owning and operating costs.



Versatility

- Customize The 980H For Your Operation
- Large Variety Of Cat® Work Tools
- Machine Arrangements For Specialized Applications **pg. 10**

Operator Comfort

- Quiet, Comfortable Cab
- Easy Entry And Exit
- Excellent Visibility
- Reduced Operator Effort
- Comfortable Seating **pg. 12**

Owning and Operating Costs

- Proven Fuel Efficiency
- Simple, Convenient Maintenance
- Unsurpassed Parts Availability
- Excellent Resale Value
- Financing Tailored To Your Operation **pg. 14**



Reliability

The Cat® 980H midsize loader – ready to work any time, any season.

- Proven technology that provides reliability from day one
- Cat design and manufacture of systems that work together as a unit
- Excellent uptime provided by the best dealer support network in the industry
- Unmatched genuine Cat parts availability
- Outstanding Cat dealer service capabilities on your job site or in the dealer shop

Proven Technology. The Cat 980H is built on the legendary 980 platform. Many of the systems designed for and proven on the 980G Series II and previous models are still in use today for the 980H. Planetary powershift transmission, cab, separated cooling system, integrated braking system, free wheel stator torque converter, frames – all contribute to the proven reliability of the 980H.

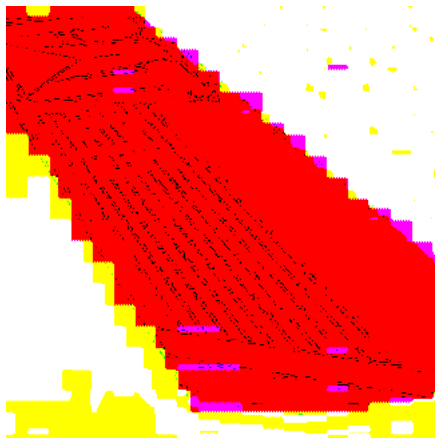

ACERT™ Technology. ACERT Technology has been proving itself in on-highway trucks since March 2003, and more recently in field tests of off-highway equipment. This technology allows Cat engines to meet durability and reliability expectations without sacrificing fuel economy or performance.



Dealer Support. The first priority of the Caterpillar® dealer is to keep your loader up and running when you need it. The entire global network of 206 independently-owned Cat dealers is the best in the world at distributing parts and equipment. They are there when and where you need them.

Parts Availability. Caterpillar provides an unsurpassed level of personalized service for your wheel loader. With 23 parts distribution centers in 11 countries, most parts can be delivered in 24 hours.

All parts supplied by Caterpillar are manufactured to original equipment specifications. Retrofit kits are available to update machines to current technology. Cat Classic™ Parts for older machines are specially made to Cat specifications at a lower cost.

All parts to repair your machine – batteries, seals, filters, fluids, hydraulics, engine parts – are designed and manufactured to work together efficiently and effectively as a system.



Remanufactured Parts. Cat engines and major components are designed to be remanufactured and provide multiple life cycles. The Cat Reman program is more extensive than most rebuild programs. Components are actually remanufactured in the factory to original specifications with necessary product updates.

Strict reuse guidelines and unparalleled quality control ensure that reman products provide the reliability and durability that you expect from Caterpillar. Reman products are stocked in distribution centers around the world and are ready to install to minimize downtime, maintain productivity and profitability.

Service Capabilities. Need routine maintenance or unplanned repair? Cat field service technicians have the experience and tools necessary to service your loader on site. Field service trucks are fully loaded with state-of-the-art tools and diagnostic equipment as well as specifications and schematics for every Cat machine. Technical experts at the dealer shop and at Caterpillar provide assistance to every field service technician.

When on-site repair isn't enough, Cat dealer shops are fully-equipped to service your loader quickly.

Dealer Support Programs. Caterpillar dealers support you with a variety of programs from financing a purchase to complete after-sale support.

- Purchase/Lease/Rent
- Caterpillar Insurance
- Investment Options
- Cat Equipment Training
- Customer Support Agreements
- S•O•SSM Services

Purchase, Lease or Rent? Your Cat dealer can help you decide the best acquisition options for your operation. They can help you calculate owning and operating costs and how the available financing options can contribute to your bottom line.



Durability

Durability built in, not added on.

- Strong, solid structures built to last
- Major components designed and manufactured to provide long hours of use and to be rebuilt for additional life
- Cat C15 engine with ACERT Technology maintains engine performance, efficiency and durability while reducing emissions
- Improved hood strength and faster lift and lower times
- Main ladder integrated into side of machine to protect steps from debris build-up



Structures. The 980H retains the same basic structures as the 980G Series II. Full box section engine end frame absorbs shock loads and twisting forces while supporting the drive line for rigid component alignment. The frame is over 90 percent robotically welded providing deep weld penetration for maximum durability and fatigue strength.

The non-engine end frame provides a solid base for the front axle, lift arms and tilt cylinders. The fabricated four-plate loader tower resists shock loads and loading stresses.

Lift arms are solid steel, providing superior strength, excellent dump clearance and reach while maintaining visibility to the bucket. The cast steel cross tube is heat treated for maximum resistance to torsion and impact loads. Z-bar linkage generates exceptional breakout forces and good rack back angle for better bucket loading and material retention.

The spread hitch design of the 980H articulation joint reduces stress loads on the hitch pin and roller bearings for long service life.



New Hood. A new hood has been designed for the 980H. Two layers thick, the new hood provides improved durability while maintaining visibility to the ground. The reinforced hood is more resistant to wind and mud build-up. The actuation system has also been improved. Electrohydraulically activated twin lift cylinders significantly reduce lift and lower time.

New Ladder. The ladder on the 980H is integrated into the side of the machine. The self-cleaning steps are protected from debris build-up. A five-degree incline allows easy entry and exit to the cab.

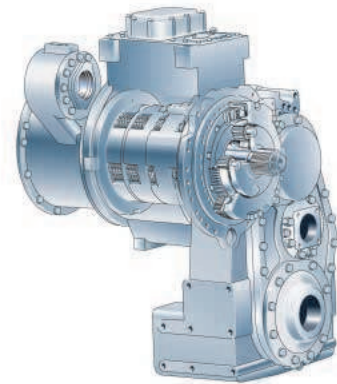

Powershift Transmission. The 980H is equipped with a transmission that has proven itself for over 40 years. And the addition of the Electronic Clutch Pressure Control (ECPC) system adds a new level of durability to the transmission.

ECPC modulates clutch engagement individually to allow smoother speed and directional shifts and provide longer component life than the transmission in the 980G Series II.



Engine. ACERT Technology combines proven systems with innovative new technologies to precisely deliver fuel to the combustion chamber. It maintains engine performance, efficiency and durability while dramatically reducing emissions.

The C15 engine used in the 980H has a strong track record of reliability, durability and power density in both off-highway equipment and on-highway trucks. In fact, millions of reliable road miles have garnered it the J.D. Power & Associates award for customer reliability. The robust design of the C15 required very few modifications to accommodate the higher cylinder pressures associated with ACERT Technology.

Although ACERT Technology itself is new, much of the componentry is the same as used in previous engines. Electronic controllers are the brains of ACERT Technology. The advanced electronic controllers used in Cat engines were first introduced in the early 1990s and have a proven track record of performance and reliability.

The C15 engine features the Cat Mechanically Actuated Electronic Unit Injection (MEUI) fuel system. The MEUI fuel system is a highly evolved system with proven reliability and durability in the field.



Integrated Systems. The Caterpillar Monitoring System (CMS) tracks critical machine systems to alert the operator to potential need for service. Three levels of warning allow the operator to assess the situation more accurately. CMS is tied to the engine, transmission, hydraulics and brakes – connecting all major systems allows the loader to work as a fully integrated system – from the linkage to the engine.

Productivity

Move more material.

- Transmission features that optimize machine performance
- Engine maintains a consistent level of productivity
- Standard and optional features that increase productivity

Autoshift. Choose between manual or automatic shift modes in the cab. This flexible feature increases operator efficiency and optimizes machine performance.

Variable Shift Control (VSC). Match transmission shifting patterns to machine applications requirements. Variable Shift Control improves shift quality and fuel efficiency in certain applications by allowing the transmission to upshift at lower engine RPMs.

Engine Idle Management System (EIMS). Four idle control settings help maximize fuel efficiency and provide flexibility in managing idle speeds based on application requirements.

Hibernate Mode allows idle speed to drop after a preset time to provide lower fuel consumption, reduced sound and emissions.

Work Mode provides flexibility in working engine idle speeds.

Warm Up Mode is designed to keep the machine consistently warm in cold conditions.

Low Voltage Mode prevents battery drain due to high electrical loads from attachments.

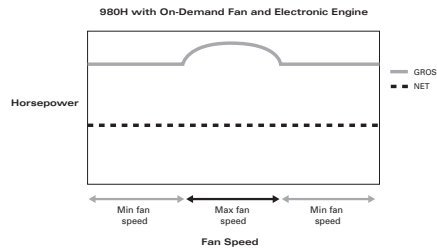

Constant Net Horsepower. The engine automatically compensates for parasitic loads, like the fan and air conditioner, to maintain a consistent level of productivity.



Command Control Steering. Reduce steering movements by a factor of 14 with Command Control Steering as compared to conventional steering. A conventional steering wheel requires two to three 360° turns to complete one turn of the loader – the Command Control wheel moves $\pm 70^\circ$ with only 26 N (6 lb) steering pressure to complete a turn – reducing operator fatigue.



Ride Control. The optional Ride Control System improves ride, performance and load retention when traveling over rough terrain. Operators gain confidence moving at higher speeds in load and carry operations decreasing cycle time and increasing productivity.

Payload Control System. Scales, designed specifically for Cat machines, are built into the lift arms to allow on-the-go weighing of material in the bucket. Operators load trucks more accurately and efficiently. Loading trucks right the first time equates to quicker cycles for the operator, increased efficiency at the scale house and more productivity for your operation.

Payload Control is available as a factory-installed option. A printer is also available for printing driver tickets and a variety of reports.



Autolube. The optional Caterpillar Autolube System provides precise, automatic lubrication of pins and bushings – during loader operation. Automatic lubrication reduces time spent on daily maintenance and downtime for unplanned repairs due to inadequate greasing – improving productivity.



Aggregate Autodig. Well-received by both experienced and novice operators, the optional Aggregate Autodig is available to automate the loading process. Operators get consistently full payloads without touching the controls.

Versatility

Build a 980H to fit your operation.

- A variety of buckets and other work tools for many different applications make the 980H a very versatile wheel loader
- Many options can be ordered factory-installed to customize the 980H for your operation
- Special machine arrangements can be provided from the factory for aggregate, forestry, scrap, steel mill and waste applications
- A high lift arrangement is available for special dump clearance needs

Work Tools and Quick Couplers.

A variety of buckets, work tools and couplers are available from the factory or your Caterpillar dealer to customize the 980H for your operation.

Quick Couplers. Quick couplers provide unmatched versatility for wheel loaders. Buckets and work tools can be changed in seconds without leaving the cab for maximum productivity.



General Purpose Buckets. General purpose buckets provide good all-around performance for stockpiling, rehandling, excavating and bank loading. A heavy duty general purpose bucket can be used for more abrasive applications.

Material Handling Buckets. The material handling bucket is a flat-floor bucket used for handling stockpiled materials such as aggregates or other easy-to-load materials requiring moderate breakout force.



Rock Buckets. Rock buckets are designed for face or bank loading in mining or quarry applications. The straight-edge rock bucket provides higher breakout force and increased dump clearance. The spade-edge rock bucket offers better penetration.

Waste Buckets. Waste buckets are designed for long life in the harsh world of refuse applications. The high capacity bucket is well-suited for loading, sorting and other transfer station work.

Coal Buckets. Coal buckets maximize productivity in loading and stockpiling applications of coal and other materials of the same density.

Heavy Duty Quarry Buckets. The heavy duty quarry bucket is available for high-impact or high-abrasion quarry applications.

Woodchip and Clean-Up Buckets. Woodchip and clean-up buckets are available for forestry and millyard applications.

Forks. Logging, millyard and pallet forks are available for forestry and material handling applications.

Specialty Work Tools. Other specialty work tools, such as material handling arms and snow plows, are available for the 980H. Contact your local Caterpillar dealer for application and availability information.



Ground Engaging Tools (GET).

Several GET options are available from Caterpillar for the 980H buckets. A cast corner adapter is incorporated into the design of the buckets that allows a tooth to be placed on the extreme corner for protection against base bucket wear.

Reversible bolt-on cutting edges (BOCE) and a bolt-on half-arrow cutting edge are also available for the 980H buckets.

The Cat K Series™ tooth system features an easier-to-install tip and provides very secure tooth retention. No special tools are required for installation or removal.

Special Machine Arrangements.

When you have a specialized operation, you need a specialized wheel loader to be productive. A variety of machine arrangements are available for the 980H.

Aggregate Applications. Looking to increase productivity in your quarry? Two packages are available for the 980H to provide that increase. The Aggregate Loader Package provides the 6.1 m³ (8 yd³) general purpose bucket.

The Premium Yard Loader Package provides the ultimate in productivity and convenience options at an exceptional value. Autolube, Aggregate Autodig, Payload Control and Ride Control will reduce operator fatigue and make your wheel loader the most productive aggregate loader available.

Forestry. The Forest Machine Arrangement equips the 980H with an extreme service transmission, heavy duty tilt cylinders and 2041 kg (4,500 lb) counterweight for the strength and durability required to be productive in this tough application. Logging and millyard forks, woodchip and clean-up buckets can be added to equip the 980H for forestry applications.

Industrial Loader. Heavy duty guarding and special features designed specifically for industrial applications, such as waste and scrap handling, allow the 980H to withstand the harshest of conditions. Work tools designed specifically for these applications can be added to the machine.



Steel Mill Applications. The Steel Mill Arrangement gives the added protection needed for extended life and lower operating costs in this rugged environment. The arrangement includes steel guarding for critical components, an extreme service transmission, heavy-duty engine and transmission mounts, hydraulic hose protection, insulated battery mounting, remote engine shutdown, remote parking brake release, transmission override, steel cable ladder, steel command control

steering shaft cover, seal mounted windshield for quick replacement, narrow steel front fenders, EcoSafe FR46 hydraulic fluid (optional), and the front access platform (optional). Slag buckets are also available.

High Lift Arrangements. A high lift arrangement is available for applications where additional dump clearance is required. All 980H buckets fit both the standard and high lift arrangements.

Operator Comfort

Comfort and convenience increase efficiency.

- Cab sound levels of 76 dB(A) provide quiet operation and reduce fatigue through the long work day
- Vibration is controlled to improve operator comfort
- Doors on both sides of the machine provide easy entry and exit
- Excellent visibility – front and rear – is provided by distortion-free flat glass, wet-arm wipers, roof channels that drain water off the ROPS posts instead of the windows and a roof overhang that keeps glare out of the operator's eyes
- Centrally located, easy to access controls and switches with clear, graphical symbols for more intuitive operation
- Cat Comfort Seat provides strong, durable seating for operators of all shapes and sizes
- Command Control Steering reduces operator effort significantly

Sound. The operator sound level for the 980H has been reduced by 4 dB(A) – to 76 dB(A) – a 50 percent improvement over the 980G Series II. The improvement in sound level was made possible by the addition of insulation to the doors and front panels, as well as the rear and floor of the cab. Cab pressurization has been improved which also contributes to the lower sound level. Also, an optional low sound attachment reduces spectator sound levels to 107 dB(A) and operator sound pressure to 72 dB(A).

Vibration. Caterpillar understands that midsize wheel loaders work in some of the harshest environments. By controlling normal machine vibrations caused by these harsh conditions, operator efficiency and productivity are improved. From the ground up, the Cat 980H is designed with many features, both standard and optional, that reduce vibration.

- The oscillating rear axle follows the contour of the ground while allowing the cab to stay steady.
- The cab is attached to the frame with rubber mounts designed to reduce shock loads from the ground.
- The articulation joint is equipped with a hydraulic valve that modulates the force of impact when the machine reaches the end of its turning radius.
- Dump stop snubbing is available to slow the bucket as it reaches the limits of travel.
- Ride Control is an option designed to reduce jolting and bouncing during load and carry operations. An accumulator acts as a shock absorber to reduce machine pitching and provide a smoother ride over rough terrain.
- Electronic sensors and hydraulics precisely match implement lever position to the speed and position of the lift arms and bucket cylinder. This precision provides smooth valve actuation and cylinder travel while virtually eliminating abruptness of movement.
- Automatic lift and lower kickouts and bucket position can be set by the operator from the cab. These electronically controlled cushioned stops eliminate the jerking and bouncing associated with abrupt stops.

Entry and Exit. An integrated ladder with self-cleaning steps keeps debris build-up to a minimum. The ladder is at a 5-degree incline for easy entry and exit.

Platforms are wide allowing safe movement to the front or rear of the machine. The main cab door opens a full 180 degrees and latches in place to allow safe navigation to the rear of the machine.



Visibility. The 980H provides excellent visibility to both the front and rear of the machine. Distortion-free flat glass stretches to the floor of the cab for excellent visibility to the bucket. Wet-arm wipers on both front and back keep the windows clean in any condition. The cab roof has channels that direct rain off the corners of the cab keeping windows clear. An overhang on all sides protects the operator from glare.

An optional windshield cleaning package provides additional steps and handrails to provide easy access for cleaning the windows.

An optional rear vision camera is available to more closely monitor movement behind the wheel loader.



Controls. The main control panel on the 980H is located high on the right ROPS post – keeping everything within reach of the operator while maintaining visibility to the ground. Clear graphical symbols make the switches easy to understand and operate.

Keeping all switches and controls conveniently placed allows better efficiency and improved productivity all while minimizing operator fatigue.

Seats. The Cat C-500 Series Comfort seat is built strong and durable and is 6-way adjustable to accommodate all-sized operators. The cast one-piece back and seat pan prevent protrusions under the cushions. The seat features an automotive-style lumbar support for maximum comfort. The right hand armrest with integrated implement controls adjusts for comfortable convenient operation.

A heated seat option is available for additional comfort in cold conditions.



Ease of Operation. Command Control Steering is a load-sensing system that links the steering wheel and frame angle positions to provide the proper amount of steering control. The speed the machine turns is proportional to the steering wheel position. Less than 26 N (6 lb) steering effort is required by the operator, regardless of conditions. Full machine articulation is accomplished with a $\pm 70^\circ$ turn of the wheel – versus two to three 360° turns of a conventional steering wheel.

The Command Control Steering wheel contains the forward/neutral/reverse switch and the upshift/downshift button – allowing the left hand to shift while remaining on the steering wheel at all times. Implement controls are integrated into the right armrest so they move with the operator.

Owning and Operating Costs

The Cat 980H – best value for your operation.

- More work for the money with proven Cat fuel efficiency
- Simplified daily maintenance with sight gauges, ground level maintenance, easy engine access, ecology drains, maintenance-free batteries increase machine uptime
- Unsurpassed parts availability reduces downtime
- Excellent resale value provided by genuine Cat quality, outstanding dealer service and unmatched dealer support programs
- Caterpillar Financial Services and Cat dealers understand your business and provide financing and customer support programs to enhance the value of your acquisition



Fuel Economy. With the 980H, horsepower and shift points can be tailored to match application requirements in turn improving fuel economy. Caterpillar allows operators to choose between two horsepower settings through the Variable Shift Control (VSC) dial. When the dial is positioned in the Standard Mode (1), operators will realize 349 constant net horsepower and shifts occurring at higher engine rpm's. In the Intermediate Mode (2) operators will experience 319 constant net horsepower and transmission shifting at lower rpm's. Using the Economy Mode (3) engine rpm's at which shifting occurs will be further reduced while constant net horsepower remains at 319.



ACERT Technology Fuel Economy.

Based on Caterpillar testing, the fuel economy of Cat engines with ACERT Technology is 3 to 5 percent better than current competing technologies. This fuel economy is directly related to the complete combustion of fuel due to the integration between the electronic control that monitors conditions, the air management system that controls air volume and the fuel injection system that delivers just the right amount of fuel as needed.

Maintenance. Proper maintenance of your wheel loader can help control expenses and lower your owning and operating costs. Using key features from the 980G Series II and adding a few of its own, the 980H provides unmatched serviceability.

- Well protected, easily visible sight gauges
- Ground level maintenance points
- Easy access to engine compartment
- Ecology drains for simple and clean fluid drainage
- Brake wear indicators for ease of inspection
- Maintenance-free batteries
- Long oil and filter change intervals
- Swing-out grill for easy access and more efficient airflow

Parts Availability. Caterpillar provides an unsurpassed level of personalized service for your wheel loader. With 23 parts distribution centers in 11 countries, most parts can be delivered in 24 hours. Easy access to parts reduces downtime waiting for parts delivery – and allows your wheel loader to be more productive.

Resale Value. Owning quality equipment is a very important factor in maintaining resale value. Cat not only supplies quality equipment but also provides the product and dealer support to ensure the reliability and durability of your machine. The high level of expertise of the Cat dealer service department ensures that repairs are done properly with genuine Caterpillar parts.

Customer Support Agreements can help you control the cost of machine ownership. Dealer support programs, like S-O-S Fluid Analysis, monitor machine condition providing more consistent uptime and machine availability. Genuine Cat quality, a known machine condition and documented service history all contribute to the high resale value of Cat equipment.



Financing. Buy, lease or rent; Cat Financial has an acquisition plan that fits your operation. The advantage of working with Cat Financial to arrange the financing of your machine is that Cat understands your business.



Serviceability

Ease of service increases productivity.

- Daily maintenance made easy with sight gauges and ground level service points
- Service is simplified with brake wear indicators, ecology drains, grouped sampling ports and easily replaceable components
- Monitoring systems and analysis programs that can detect problems before they happen

Daily Maintenance. Sight gauges and ground level maintenance points make daily maintenance simple and easy. Sight gauges are provided for transmission oil, hydraulic oil and radiator coolant. All are easily visible and eliminate the risk of contamination from opening reservoirs daily.

Ground level access to maintenance points reduces daily start-up time, ensures that daily maintenance gets done and reduces operator fatigue from climbing on the machine to do daily checks.

Grease fittings for both the non-engine end frame and engine end frame lubrication points are contained in the front hitch area. Remote grease lines come together in two convenient central lube banks on the left side of the machine. U-joints are lifetime lubricated.

Batteries are maintenance free and easy to access in slide-out battery boxes on both sides of the machine.

Brake Wear Indicators. A port on the axle contains a visual indicator to determine brake wear. A service technician can easily measure and track brake wear at a glance.

Ecology Drains. Simple, clean draining of engine oil, transmission oil and hydraulic oil is standard on the 980H with the ecology drain. The axle oil ecology drain is optional.



S•O•S Fluid Sampling. Oil sampling valves allow quick access to engine, transmission and hydraulic oils for S•O•S analysis. Sampling ports for steering, transmission, and brakes are grouped in lockable service compartments behind the cab. The S•O•S program enables problems to be detected before they occur and allows more convenient scheduling of service.



Autolube. Reduce time spent on daily maintenance and downtime for unplanned repairs due to inadequate greasing with the optional Caterpillar Automatic Lubrication System. Precise lubrication of pins and bushings at specific intervals improves component wear and reduces ground contamination from excessive greasing.



Cooling. The Next Generation Modular Radiator (NGMR) cores are a modular design permitting replacement of a single core without removing the entire radiator – reducing repair costs and downtime. A sight gauge located on the shunt tank allows quick service checks. The perforated, corrugated grill swings out for easy access to the cooling cores.

Full width air conditioner condenser and oil cooler cores also swing out 45° to allow easy cleaning of the rear radiator face. Hinged panels on either side of the radiator support structure provide access to the front face of the radiator and ATAAC for easy cleaning.

Cab. The entire operator station can be removed in about 45 minutes and is easily replaceable. Four wiring harnesses, two heater lines, the steering drive shaft and two bolts for the brake valve are all that need to be disconnected – no wires need to be cut. The air conditioner is unhooked using the quick disconnects so no refrigerant is lost.

An optional windshield cleaning package consists of two steps for the loader front frame and two additional handrails. This optional package allows access to the full front windshield.



Caterpillar Monitoring System.

Trust the Caterpillar Monitoring System to watch out for your machine. Continuous monitoring of critical systems ensures that you'll be warned of problems before they turn serious. Three categories of warnings – from visual to visual/audible – will be provided to the operator, depending on the severity of the situation.

Complete Customer Support. Cat field service technicians have the experience and tools necessary to service your loader on site. Field service trucks are fully loaded with state-of-the-art tools and diagnostic equipment as well as specifications and schematics for every Cat machine. Technical experts at the dealer shop and at Caterpillar provide assistance to every field service technician.

When on-site repair isn't enough, Cat dealer shops are fully-equipped to service your loader quickly.

Engine

Engine Model	Cat® C15 ACERT™	
Gross Power – SAE J1995	293 kW	393 hp
Net Power – ISO 9249	260 kW	349 hp
Net Power – SAE J1349	260 kW	349 hp
Net Power – 80/1269/EEC	263 kW	353 hp
Peak Torque (Net) @ 1,200 rpm	1619 N-m	1,244 ft-lb
Bore	137 mm	5.4 in
Stroke	171.5 mm	6.75 in
Displacement	15.2 L	928 in ³

- Caterpillar engine with ACERT Technology – EPA Tier 3, EU Stage III Compliant
- These ratings apply at 1,800 rpm when tested under the specified standard conditions.
- Power rating conditions for net power advertised is the power available when the engine is equipped with alternator, air cleaner, muffler and on-demand hydraulic fan drive at maximum fan speed.

Weights

Operating Weight	30 519 kg	67,294 lb
------------------	-----------	-----------

- For 5.7 m³ (7.5 yd³) general purpose bucket with BOCE

Buckets

Bucket Capacities	3.8-6.1 m ³	5.0-8.0 yd ³
Max Bucket Capacity	6.1 m ³	8 yd ³

Operating Specifications

Static Tipping Load, Full Turn	19 496 kg	42,989 lb
Breakout Force	199 kN	44,775 lb

- For 5.7 m³ (7.5 yd³) general purpose bucket with BOCE

Transmission

Forward 1	6.6 km/h	4.1 mph
Forward 2	11.8 km/h	7.3 mph
Forward 3	20.7 km/h	12.9 mph
Forward 4	36.3 km/h	22.6 mph
Reverse 1	7.6 km/h	4.7 mph
Reverse 2	13.5 km/h	8.4 mph
Reverse 3	23.6 km/h	14.7 mph
Reverse 4	41.5 km/h	25.8 mph

- Maximum travel speeds (29.5-25 tires).

Hydraulic System

Bucket/Work Tool System – Pump Output	464 L/min	123 gal/min
Bucket/Work Tool System – Relief Valve Setting	20 700 kPa	3,000 psi
Hydraulic Cycle Time – Raise	6 Seconds	
Hydraulic Cycle Time – Dump	2.1 Seconds	
Hydraulic Cycle Time – Lower, Empty, Float Down	3.4 Seconds	
Hydraulic Cycle Time – Total	11.5 Seconds	
Pilot System – Pump Output	464 L/min	122.58 gal/min

- Implement System (Standard), Gear-Type Pump – Rated at 2,100 rpm and 6900 kPa (1,000 psi).

Brakes

Brakes	Meets required standards.
--------	---------------------------

- Meet OSHA, SAE J1473 OCT90 and ISO 3450-1996 standards.

Axles

Front	Fixed front	
Rear	Oscillating ±13°	
Maximum Single-Wheel Rise and Fall	550 mm	21.7 in

Tires

Tires	Choose from a variety of tires to match your application.
<ul style="list-style-type: none">Choice of:<ul style="list-style-type: none">29.5R25, L229.5R25, L329.5R25, L3 (STL2+)29.5R25, L3 (STL3)29.5R25, L3 (VSDL)29.5R25, L3 (VMT)29.5R25, L529.5-25, L329.5-25, L429.5-25, L5NOTE: In certain applications (such as load and carry) the loader's productive capabilities might exceed the tires' tonnes-km/h (ton-mph) capabilities. Caterpillar recommends that you consult a tire supplier to evaluate all conditions before selecting a tire model.	

Cab

ROPS/FOPS	Meets SAE and ISO standards.
<ul style="list-style-type: none">Caterpillar cab with integrated Rollover Protective Structure (ROPS) are standard in North America and Europe.ROPS meets SAE J1040 APR88 and ISO 3471:1994 criteria.Falling Objects Protective Structure (FOPS) meets SAE J231 JAN81 and ISO 3449:1992 Level II criteria.The operator sound pressure level measured according to the procedures specified in ISO 6394:1998 is 76 dB(A) for the cab offered by Caterpillar, when properly installed and maintained and tested with the doors and windows closed.Hearing protection may be needed when operating with an open operator station and cab (when not properly maintained or doors/windows open) for extended periods or in noisy environment.The sound pressure level is 112 dB(A) measured according to the static test procedure and conditions specified in ISO 6395:1998 for a standard machine configuration.	

Service Refill Capacities

Fuel Tank – Standard	479 L	127 gal
Cooling System	83 L	22 gal
Crankcase	64 L	17 gal
Transmission	62 L	16 gal
Differentials and Final Drives – Front	87 L	23 gal
Differentials and Final Drives – Rear	87 L	23 gal
Hydraulic System (Including Tank)	250 L	66 gal
Hydraulic Tank	125 L	33 gal

Operating Specifications

		Standard Machine with General Purpose Buckets						
		Teeth	Teeth and Segments	Bolt-On Edges	Flushmounted Teeth with Tips	Teeth	Teeth and Segments	Bolt-On Edges
Rated bucket capacity (§)	m ³	4.2	4.5	4.6	5.4	4.7	4.9	5.0
	yd ³	5.5	5.75	6.0	7.0	6.0	6.25	6.5
Struck capacity (§)	m ³	3.66	3.81	3.87	4.61	4.03	4.19	4.25
	yd ³	4.78	4.98	5.06	6.03	5.27	5.48	5.56
Width (§)	mm	3533	3533	3447	3513	3533	3533	3447
	ft/in	11'7"	11'7"	11'4"	11'6"	11'7"	11'7"	11'4"
Dump clearance at full lift and 45° discharge (§)	mm	3305	3305	3458	3138	3229	3229	3385
	ft/in	10'10"	10'10"	11'4"	10'4"	10'7"	10'7"	11'1"
Reach at full lift and 45° discharge (§)	mm	1554	1554	1407	1739	1601	1601	1457
	ft/in	5'1"	5'1"	4'7"	5'8"	5'3"	5'3"	4'9"
Reach with lift arm horizontal and bucket level (§)	mm	3000	3000	2790	3260	3090	3090	2880
	ft/in	9'10"	9'10"	9'2"	10'8"	10'2"	10'2"	9'5"
Digging depth (§)	mm	90	125	125	91	90	125	125
	in	3.5	4.9	4.9	3.6	3.5	4.9	4.9
Overall length (§)	mm	9480	9480	9248	9700	9570	9570	9338
	ft/in	31'1"	31'1"	30'4"	31'10"	31'5"	31'5"	30'8"
Overall height with bucket at full raise (§)	mm	6141	6141	6141	6216	6217	6217	6217
	ft/in	20'2"	20'2"	20'2"	20'5"	20'5"	20'5"	20'5"
Loader clearance circle with bucket in carry position (§)	mm	15 925	15 925	15 716	16 006	15 972	15 972	15 762
	ft/in	52'3"	52'3"	51'7"	52'6"	52'5"	52'5"	51'9"
Static tipping load straight*	kg	22 767	22 310	22 341	22 174	22 417	22 063	22 093
	lb	50,201	49,194	49,262	48,894	49,429	48,649	48,715
Static tipping load full 37° turn	kg	20 380	20 034	20 069	19 742	20 439	19 801	19 836
	lb	44,938	44,175	44,252	43,531	45,068	43,661	43,738
Breakout force** (§)	kN	273	251	252	227	252	233	234
	lb	61,425	56,475	56,700	51,075	56,700	52,425	52,650
Operating weight* (§)	kg	30 156	30 334	30 261	30 351	30 253	30 432	30 359
	lb	66,494	66,886	66,726	66,924	66,708	67,103	66,942

* Static tipping loads and operating weights shown are based on standard machine configuration with 29.5R25, L-3 Michelin tires, full fuel tank, coolant, lubricants and operator.

** Measured 102 mm (4.0 in) behind tip of cutting edge with bucket hinge pin as pivot point in accordance with SAE J732C.

(§) Specifications and ratings conform to all applicable standards recommended by the Society of Automotive Engineers, including SAE Standards J732C governing loader ratings.

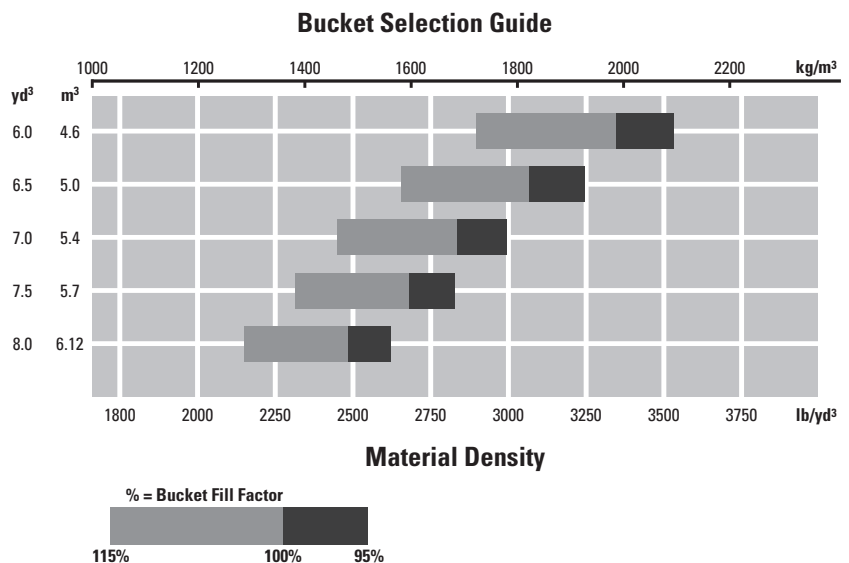

		Standard Machine with General Purpose Buckets								
		Teeth	Teeth and Segments	Bolt-On Edges	Teeth	Teeth and Segments	Bolt-On Edges	Teeth	Teeth and Segments	Bolt-On Edges
Rated bucket capacity (§)	m ³	5.0	5.3	5.4	5.4	5.6	5.7	5.73	6.0	6.12
	yd ³	6.5	6.75	7.0	7.0	7.25	7.5	7.5	7.75	8.0
Struck capacity (§)	m ³	4.38	4.55	4.61	4.68	4.85	4.92	4.85	5.1	5.2
	yd ³	5.73	5.95	6.03	6.12	6.34	6.44	6.34	6.67	6.8
Width (§)	mm	3533	3533	3447	3533	3533	3447	3533	3533	3447
	ft/in	11'7"	11'7"	11'4"	11'7"	11'7"	11'4"	11'7"	11'7"	11'4"
Dump clearance at full lift and 45° discharge (§)	mm	3165	3165	3322	3124	3124	3272	3075	3075	3238
	ft/in	10'5"	10'5"	10'11"	10'3"	10'3"	10'9"	10'1"	10'1"	10'7"
Reach at full lift and 45° discharge (§)	mm	1647	1647	1505	1675	1675	1534	1729	1729	1594
	ft/in	5'5"	5'5"	4'11"	5'6"	5'6"	5'0"	5'8"	5'8"	5'3"
Reach with lift arm horizontal and bucket level (§)	mm	3170	3170	2960	3220	3220	3010	3292	3292	3083
	ft/in	10'5"	10'5"	9'9"	10'7"	10'7"	9'11"	10'10"	10'10"	10'1"
Digging depth (§)	mm	90	125	125	90	125	125	99	125	125
	in	3.5	4.9	4.9	3.5	4.9	4.9	3.9	4.9	4.9
Overall length (§)	mm	9650	9650	9418	9700	9700	9468	9778	9778	9540
	ft/in	31'8"	31'8"	30'11"	31'10"	31'10"	31'1"	32'1"	32'1"	31'4"
Overall height with bucket at full raise (§)	mm	6287	6287	6287	6360	6360	6360	6451	6451	6451
	ft/in	20'8"	20'8"	20'8"	20'10"	20'10"	20'10"	21'2"	21'2"	21'2"
Loader clearance circle with bucket in carry position (§)	mm	16 015	16 015	15 803	16 041	16 041	15 829	16 087	16 087	15 868
	ft/in	52'7"	52'7"	51'10"	52'8"	52'8"	51'11"	52'9"	52'9"	52'1"
Static tipping load straight*	kg	22 201	21 848	21 880	22 052	21 711	21 735	23 328	22 939	22 971
	lb	48,953	48,175	48,245	48,625	47,873	47,926	51,438	50,581	50,651
Static tipping load full 37° turn	kg	19 933	19 598	19 634	19 952	19 467	19 496	20 860	20 493	20 532
	lb	43,952	43,214	43,293	43,994	42,925	42,989	45,996	45,187	45,273
Breakout force** (§)	kN	236	219	220	227	211	212	213	198	199
	lb	53,100	49,275	49,500	51,075	47,475	47,700	47,925	44,550	44,775
Operating weight* (§)	kg	30 343	30 522	30 448	30 415	30 593	30 519	31 287	31 462	31 370
	lb	66,906	67,301	67,138	67,065	67,458	67,294	68,988	69,374	69,171

Operating Specifications

		Heavy Duty General Purpose			Material Handling			Rock Bucket		
		Teeth	Teeth and Segments	Bolt-On Edges	Teeth	Teeth and Segments	Bolt-On Edges	Teeth	Teeth and Segments	Teeth and Segments
Rated bucket capacity (§)	m ³	5.4	5.6	5.7	5.5	5.7	5.9	4.2	4.5	4.5
	yd ³	7.0	7.25	7.5	7.25	7.5	7.75	5.49	5.89	5.89
Struck capacity (§)	m ³	4.68	4.85	4.92	4.7	4.8	5.0	3.53	3.73	3.73
	yd ³	6.12	6.34	6.44	6.15	6.28	6.54	4.61	4.88	4.88
Width (§)	mm	3533	3533	3447	3533	3533	3447	3504	3504	3504
	ft/in	11'7"	11'7"	11'4"	11'7"	11'7"	11'4"	11'6"	11'6"	11'6"
Dump clearance at full lift and 45° discharge (§)	mm	3142	3142	3296	2943	2943	3110	3183	3183	3184
	ft/in	10'4"	10'4"	10'10"	9'8"	9'8"	10'2"	10'5"	10'5"	10'5"
Reach at full lift and 45° discharge (§)	mm	1693	1693	1547	1610	1610	1478	1792	1792	1792
	ft/in	5'7"	5'7"	5'1"	5'3"	5'3"	4'10"	5'11"	5'11"	5'11"
Reach with lift arm horizontal and bucket level (§)	mm	3220	3220	3009	3320	3320	3109	3258	3258	3258
	ft/in	10'7"	10'7"	9'10"	10'11"	10'11"	10'2"	10'8"	10'8"	10'8"
Digging depth (§)	mm	78	118	118	111	191	151	90	125	125
	in	3.1	4.6	4.6	4.4	7.5	5.9	3.5	4.9	4.9
Overall length (§)	mm	9691	9691	9461	9816	9816	9586	9725	9725	9725
	ft/in	31'10"	31'10"	31'0"	32'2"	32'2"	31'5"	31'11"	31'11"	31'11"
Overall height with bucket at full raise (§)	mm	6287	6287	6287	6382	6382	6382	6383	6383	6383
	ft/in	20'8"	20'8"	20'8"	20'11"	20'11"	20'11"	20'11"	20'11"	20'11"
Loader clearance circle with bucket in carry position (§)	mm	16 033	16 033	15 823	16 111	16 111	15 901	16 023	16 023	16 023
	ft/in	52'7"	52'7"	51'11"	52'10"	52'10"	52'2"	52'7"	52'7"	52'7"
Static tipping load straight*	kg	21 299	20 951	21 098	20 960	20 612	20 648	21 939	21 345	21 602
	lb	46,964	46,197	46,521	46,217	45,449	45,529	48,375	47,066	47,632
Static tipping load full 37° turn	kg	19 031	18 700	18 852	18 733	18 416	18 458	19 669	19 094	19 332
	lb	41,963	41,234	41,569	41,306	40,607	40,700	43,370	42,102	42,627
Breakout force** (§)	kN	225	209	210	207	182	194	223	205	205
	lb	50,625	47,025	47,250	46,575	40,950	43,650	50,175	46,125	46,125
Operating weight* (§)	kg	31 154	31 330	31 148	30 868	31 044	30 953	30 494	30 776	30 745
	lb	68,695	69,083	68,681	68,064	68,452	68,251	67,239	67,861	67,793

* Static tipping loads and operating weights shown are based on standard machine configuration with 29.5R25, L-3 Michelin tires, full fuel tank, coolant, lubricants and operator.

** Measured 102 mm (4.0 in) behind tip of cutting edge with bucket hinge pin as pivot point in accordance with SAE J732C.

(§) Specifications and ratings conform to all applicable standards recommended by the Society of Automotive Engineers, including SAE Standards J732C governing loader ratings.

		Rock Bucket – Spade		HD Quarry	Waste	Coal	High Lift Change in Specs
		Bolt-On Edges	Bolt-On Edges	Teeth and Segments	Bolt-On Edges	Bolt-On Edges	
Rated bucket capacity (§)	m ³	4.5	4.8	4.5	9.75	8.0	—
	yd ³	5.89	6.28	5.89	12.75	10.46	
Struck capacity (§)	m ³	3.7	4.0	3.79	9.4	7.2	—
	yd ³	4.84	5.23	4.96	12.29	9.42	
Width (§)	mm	3516	3670	3500	3886	3607	—
	ft/in	11'6"	12'0"	11'6"	12'9"	11'10"	
Dump clearance at full lift and 45° discharge (§)	mm	3351	3719	3167	2903	2933	221
	ft/in	11'0"	12'2"	10'5"	9'6"	9'7"	9"
Reach at full lift and 45° discharge (§)	mm	1591	1994	1821	1686	1662	2.8
	ft/in	5'3"	6'7"	6'0"	5'6"	5'5"	0.1"
Reach with lift arm horizontal and bucket level (§)	mm	2997	3097	3291	3402	3364	160
	ft/in	9'10"	10'2"	10'10"	11'2"	11'0"	6"
Digging depth (§)	mm	125	385	117	151	146	(2)
	in	4.9	15.2	4.6	5.9	5.7	(0.08)
Overall length (§)	mm	9455	9035	9755	9879	9837	199
	ft/in	31'0"	29'8"	32'0"	32'5"	32'3"	8"
Overall height with bucket at full raise (§)	mm	6377	6377	6383	6994	6526	221
	ft/in	20'11"	20'11"	20'11"	22'11"	21'5"	9"
Loader clearance circle with bucket in carry position (§)	mm	15 886	15 678	16 034	16 458	16 180	168
	ft/in	52'1"	51'5"	52'7"	54'0"	53'1"	7"
Static tipping load straight*	kg	22 015	21 349	20 658	20 805	20 574	(1774)
	lb	48,543	47,075	45,551	45,875	45,366	(3912)
Static tipping load full 37° turn	kg	19 728	19 094	18 413	18 516	18 398	(1620)
	lb	43,500	42,102	40,601	40,828	40,568	(3572)
Breakout force** (§)	kN	213	194	203	160	163	3.5
	lb	47,925	43,650	45,675	36,000	36,675	787.5
Operating weight* (§)	kg	30 565	30 830	31 389	31 599	30 975	129
	lb	67,396	67,980	69,213	69,676	68,300	284

Dimensions

All dimensions are approximate.

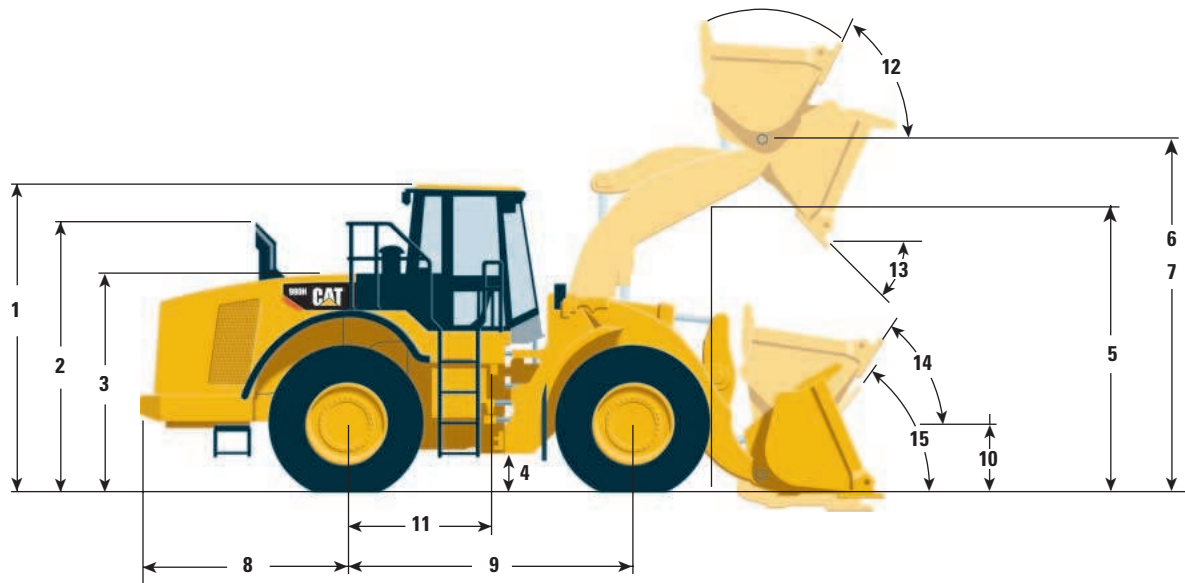

1	Height to top of ROPS	3765 mm	12'4"
2	Height to top of exhaust pipe	3716 mm	12'2"
3	Height to top of hood	2716 mm	8'11"
4	Ground clearance with 29.5R25 L-3 Michelin (see Tire Options chart for other tires)	442 mm	1'5"
5	Lift arm clearance @ maximum lift	3764 mm	12'4"
6	B-Pin height	4505 mm	14'9"
7	Optional lift height	4726 mm	15'6"
8	Center line of rear axle to edge of counterweight	2493 mm	8'2"
9	Wheelbase	3700 mm	12'2"
10	Height to center line of axle	867 mm	2'10"
11	Center line of rear axle to hitch	1850 mm	6'1"
12	Rack back @ maximum lift	61°	
13	Dump angle @ maximum lift	47°	
14	Rack back @ carry	49°	
15	Rack back @ ground	41°	

Tread width for 29.5-25 is 2440 mm (8'0")

Tires	Width over tires		Ground clearance		Change in vertical dimensions		Change in operating weight		Change in static tipping load	
	mm	inches	mm	inches	mm	inches	kg	lb	kg	lb
29.5R25, (L-2/L-3), Goodyear	3269	128.7	463	18.2	21	0.8	-91	-200.7	129	284.4
29.5R25, (L-3), Michelin	3227	127.0	442	17.4	0	0.0	0	0	0	0
29.5R25, (L-3 STL2+), Continental	3264	128.5	452	17.8	10	0.4	71	156.6	509	1,122.3
29.5R25, (L-3 STL3), Continental	3264	128.5	450	17.7	8	0.3	-16	-35.3	441	972.4
29.5R25, (L-3 VMT), Bridgestone	3211	126.4	469	18.5	27	1.1	93	205.1	-43	94.8
29.5R25, (L-3 VSDL), Bridgestone	3202	126.1	479	18.9	37	1.5	1311	2,890.8	1245	2,745.2
29.5R25, (L-5), Michelin	3212	126.5	458	18.0	16	0.0	836	1,843.4	587	1,294.3
29.5R25, (L-5), Michelin	3231	127.2	467	18.4	25	1.0	1318	2,906.2	1058	2,332.9
29.5-25, (L-3), Goodyear	3253	128.1	444	17.5	2	0.0	-297	-654.9	-206	454.2
29.5-25, (L-4), Firestone	3194	125.7	481	18.9	39	1.5	75	165.4	-460	-1,014.3
29.5-25, (L-4), Goodyear	3284	129.3	483	19.0	41	1.6	330	727.7	411	906.3
29.5-25, (L-5), Firestone	3197	125.9	488	19.2	46	1.8	613	1,351.7	859	1,894.1
29.5-25, (L-5), Goodyear	3266	128.6	488	19.2	46	1.8	942	2,077.1	943	2,079.3

Standard Equipment

Standard equipment may vary. Consult your Caterpillar dealer for details.

Electrical

- Alarm, back-up
- Alternator (80-amp, brushless)
- Batteries, maintenance-free (4) 1000 CCA
- Lighting system, halogen (6 total)
- Main disconnect switch
- Starter, electric, heavy-duty
- Starting and charging system (24-volt)
- Starting receptacle for emergency start

Operator Environment

- Air conditioner/HVAC system
- Bucket/Work Tool function lockout
- Cab, pressurized and sound suppressed
 - ROPS/FOPS, radio ready (entertainment) includes antenna, speakers, converter (12-volt, 10-amp) and power port
- Cigar lighter and ashtray
- Coat hooks (2) with straps
- Command Control Steering
- Controls, bucket/work tool electro-hydraulic
- Heater and defroster
- Horns, electric (steering wheel mounted)
- Computerized Monitoring System
 - Instrumentation, Gauges:
 - Digital gear range indicator
 - Engine coolant temperature
 - Fuel level
 - Hydraulic oil temperature
 - Speedometer/Tachometer
 - Transmission oil temperature
 - Instrumentation, Warning Indicators:
 - Axle oil temperature
 - Electrical, alternator output
 - Engine air filter restriction
 - Engine oil pressure
 - Fuel level and pressure
 - Hydraulic filter bypass
 - Hydraulic oil level
 - Parking brake
 - Service brake oil pressure
 - Primary steering oil pressure
 - Transmission filter bypass
- Lunchbox and beverage holders
- Mirrors, rearview (externally mounted)
- Seat, Cat Comfort (cloth) air suspension
- Seat belt, retractable, 51 mm (2 in) wide
- Steering column, adjustable, tilt and telescope
- Wet-arm, wipers/washers (front and rear)
 - Intermittent front wiper
- Window, sliding (left and right side)

Power Train

- Brakes, full hydraulic enclosed wet-disc
 - with Integrated Braking System (IBS) and brake wear indicator pin
- Engine, Cat C15 with ACERT Technology and ATAAC
- Fan, radiator, hydraulically driven, variable speed (temperature sensing)
- Filters, fuel/engine air, primary/secondary
- Fuel priming pump (electric)
- Fuel/water separator
- Muffler, sound suppressed
- Precleaner, engine air intake
- Radiator, Next Generation Modular (NGMR)
- Starting aid (ether)
- Switch, transmission neutralizer lockout
- Torque converter (free wheel stator)
- Transmission, automatic planetary power shift (4F/4R)
- Variable Shift Control (VSC)

Other

- Automatic bucket positioner, in-cab adjustable
 - Counterweight
 - Couplings, Caterpillar O-ring face seals
 - Doors, service access (locking)
 - Ecology drains for engine, transmission and hydraulics
 - Fenders, steel front with mud flaps/rear with extensions
 - Guard, power train and crankcase
 - Hitch, drawbar with pin
 - Hood, non-metallic power tilting
 - Hoses, Cat XT™
 - Hydraulic oil cooler (swing-out)
 - Kickout, lift and tilt, automatic (in-cab adjustable)
 - Linkage, Z-bar, cast crosstube/tilt lever
 - Oil sampling valves
 - Product Link ready
 - Remote diagnostic pressure taps
 - Sight Gauges:
 - Engine coolant
 - Hydraulic oil level
 - Transmission oil level
 - Steering, load sensing
 - Vandalism protection caplocks
- ### Tires, Rims and Wheels
- A tire must be selected from the mandatory attachments section. Base machine price includes a tire allowance.
- ### Antifreeze
- Premixed 50% concentration of Extended Life Coolant with freeze protection to -34° C (-29° F).

Optional Equipment

Optional equipment may vary. Consult your Caterpillar dealer for details.

Aggregate Autodig
Alternator, 95-amp
Autolube
Axle ecology drain
Axle oil cooler ready
Axle oil cooler
Buckets and work tools
Bucket Ground Engaging Tools (GET) – see Cat dealer for details
Camera, rear vision (custom product)
CB radio ready (20-amp)
Cooling package, high ambient 50° C (122° F)
Differentials, limited slip (front or rear), No-SPIN (rear axle only)
Fan, auto-reversing
Fast fill system, fuel
Fenders, roading
Fenders, narrow
Guard, front window
Guard, front window, forestry
Guard, front window, waste
Heater, engine coolant
High lift arrangement, two- and three-valve
Hydraulic arrangement, three-valve
Joystick control
Lights, directional
Lights, high intensity discharge (HID)
Light, warning beacon
Machine Security System
Mirrors, heated, external
Mirrors, rearview, interior
Payload Control System
 Payload Control System printer
Platform, window cleaning
Precleaner, turbine
Precleaner, turbine/trash
Radio, AM/FM Weatherband (CD)
Ride Control System, two- and three-valve
Rubber-mounted cab glass
Seat, heated
Seat belt, 76 mm (3 in) wide
Steering, secondary
Sun visor, front
Transmission, extreme service
Special Machine Arrangements
 8-yd Aggregate Loader
 Aggregate Yard Loader
 Forest Machine
 Industrial Loader Arrangement
 Steel Mill Arrangement

Notes

980H Wheel Loader

For more complete information on Cat products, dealer services,
and industry solutions, visit us on the web at www.cat.com

© 2008 Caterpillar
All Rights Reserved
Printed in U.S.A.

Materials and specifications are subject to change without notice.
Featured machines in photos may include additional equipment.
See your Caterpillar dealer for available options.

AEHQ5631-04 (4-08)

Replaces AEHQ5631-03

CAT, CATERPILLAR, SAFETY.CAT.COM, their respective logos, "Caterpillar Yellow"
and the POWER EDGE trade dress, as well as corporate and product identity used
herein, are trademarks of Caterpillar and may not be used without permission.

CATERPILLAR[®]