

988H/990H

Large Wheel Loader Millyard Arrangements



Engine – 988H

Engine Model	Cat® C18 ACERT™	
Gross Power	414 kW	555 hp
Net Power – EEC 80/1269	373 kW	501 hp
Net Power – ISO 14396	393 kW	532 hp

Operating Specifications – 988H

Tipping Load – Straight	34 338 kg	75,702 lb
Tipping Load – Articulated 37°	29 819 kg	65,740 lb
Operating Weight	58 330 kg	128,328 lb

Engine – 990H

Engine Model	Cat® C27 ACERT™	
Gross Power	512 kW	687 hp
Net Power – EEC 80/1269	468 kW	627 hp
Net Power – ISO 9249	468 kW	627 hp

Operating Specifications – 990H

Tipping Load – Straight	40 059 kg	88,315 lb
Tipping Load – Articulated 37°	35 289 kg	77,799 lb
Operating Weight	89 963 kg	198,334 lb

Millyard Features

Productivity

Productivity is critical to your bottom line. Cat large wheel loaders offer features and systems that help improve performance and lower your costs.

Reliability

Cat large wheel loaders offer field proven components and systems, high hour machine life standards and multiple rebuild options for continued uptime and long machine life.

Safety

Caterpillar continues to be proactive in developing machines that meet or exceed safety standards. Safety is an integral part of all machines and system designs, and can be seen throughout the wheel loaders models.

Serviceability

Easy access to the engine and other key serviceability features make servicing customer machines and in-field component exchange quick, easy, and efficient.

Versatility

An extensive range of work tools and bucket styles are available including woodchip buckets, forks, and other attachments to customize these machines for your operation.



Contents

Productivity	3
Fuel Efficiency	4
Reliability	5
Safety	6
Serviceability	7
Operator Comfort	8
Versatility	9
Customer Support	10
Specifications	11
Notes	15

In the harsh environment of a millyard application, you need a wheel loader designed for the job. Since 1963, the Cat® Large Wheel Loaders have helped more customers than any other manufacturer's model in this wheel loader size class. Read on to learn more about how Cat log loaders deliver sustainable productivity, fuel efficiency, serviceability, reliability and versatility.



Productivity

Improving your bottom line

Purpose Built Linkage

The 988H and 990H log loader arrangements include a purpose built linkage designed to optimize machine performance for the log loading application. Larger lift and tilt cylinders with extra counterweight allow the machines to unload an on-highway truck with a single pass. Third valve hydraulics allow for top clamp operation to secure the log load.

The optional Ride Control attachment cushions the lift arms when operating with a log load, improving operator comfort and productivity.

Positive Flow Control (PFC) (988 only)

PFC has concurrent pump and valve control and a force feedback system that keeps displacement where it is required for optimized pump control. By optimizing pump control, hydraulic oil flow is proportionate to implement lever stroke. The benefits include:

- Lowered fuel consumption
- Improved hydraulic response, giving the operator a better feel and control of the forks
- Improved power efficiency and lower system heat

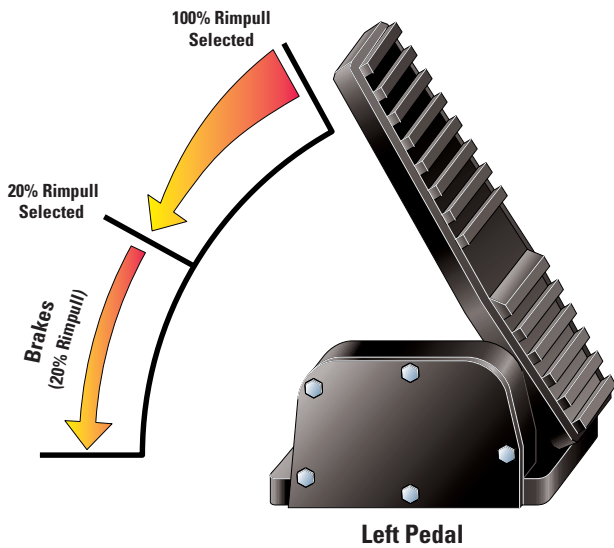

Fuel Efficiency

Minimizing costs

Auto Idle Kickdown (988 only)

If an operator is not actively operating a machine for a period of time, the AIK system will temporarily reduce engine speed to save fuel. The system will automatically resume the engine speed at the previous setting when the operator engages the implement control pod, the F-N-R switch or the STIC steer.

Idle Shutdown (988 only)

The engine will automatically shut down after the machine has been in a safe idling state for an extended amount of time. The operator in the cab will be audibly and visually warned before the system shuts down.

Impeller Clutch Torque Converter (ICTC) and Rimpull Control System

ICTC combined with the RCS allows the operator maximum flexibility in modulating rimpull

Left brake pedal modulates rimpull from 100 to 25 percent for reduced tire slippage and wear. After 25 percent is achieved, further pedal travel applies the brakes.

RCS reduces the potential for wheel slippage without reducing the hydraulic efficiency. An in-cab switch allows the operator to set a percentage of maximum rimpull to meet operating conditions. Four settings are available, and operators can set rimpull at 60, 70, 80 or 90 percent.

Torque Converter Lock-Up Clutch

A lock-up clutch torque converter provides direct drive efficiency which translates into improved fuel economy in a millyard application.

Reliability

Maximizing uptime, long life – it's what you expect from your Cat Wheel Loader

Structures

Cat Large Wheel Loader structures are designed with superior durability for multiple machine rebuilds by combining the use of robotic welding and castings in critical high stress areas. More than 80 percent of the machine structure is robotically welded to provide highly consistent welds and increased strength. Castings are also used in several areas to increase strength by helping spread the loads and reduce the number of parts.

Front Frame and Rear Frame

Highly engineered and a field proven combination, Cat Large Wheel Loaders use high strength plates and castings which distribute loads and increase structural robustness. A key differentiator from other manufactures machines is the box section rear frame and box section loader tower. The box section absorbs tensional forces generated in a loading cycle, maintaining alignment for hitch pins and driveline. The box shaped loader tower resists shock and torsional loads, maintaining hitch and loader linkage pin alignment, maximizing pin life.

Axle-Shaft, Oil Disc Brakes

These brakes are adjustment free, fully hydraulic and completely sealed. Disc face grooves provide cooling even when brakes are applied for a longer component life.

Location of brakes allow for improved serviceability. The axle shaft brake design allows for brake service while leaving the final drive intact.

Axle-shaft brakes require less force by operating on the low torque side of the axle. Combined with improved axle oil circulation for increased cooling, the oil-enclosed, multiple disc brake design improves durability.

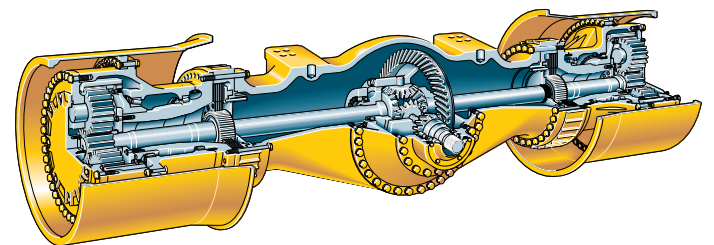
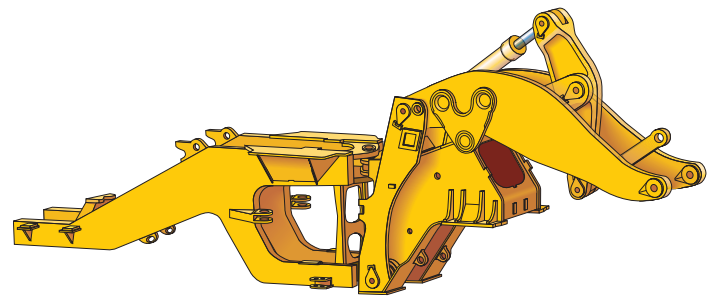

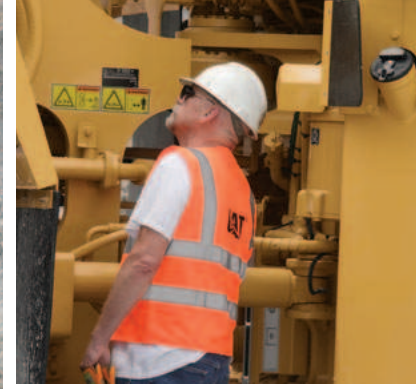

Safety

Built to protect you

Entry and Exit

Getting on and off the machine is one of the leading causes of injury on a job site. Cat Large Wheel Loaders have a number of features to ensure your operator gets safely on and off the machine. Cat Large Wheel Loaders include primary and secondary stairwell exits, punch stamped tread plates, ground level nighttime stairwell light switch, full perimeter railings on upper platforms, side platform emergency egress and toe kicks and optional roading fenders.

Rearview Camera

With the new optional rearview camera, visibility is greatly enhanced. The camera is located in a pocket on the grill to protect it from damage and the elements. The camera can be set to activate only when the transmission is in reverse to help eliminate distractions in the cab, especially when in dark environments.

Visibility

Cat Large Wheel Loaders offer a number of standard and optional features to enhance job site visibility. Standard and optional features include long life LED lights, articulated wiper/washer system with intermittent features, optional rear vision camera, optional high intensity discharge lights, optional warning beacon and optional turn signals. The rearview camera display can accommodate up to three cameras which can be configured in a variety of ways by your local Cat dealer. Object detection kits are also available through your local Cat dealer.

Serviceability

Easy to maintain. Easy to service.

Optional Swing Out Radiator Fan (988 only)

The optional swing out radiator fan provides for easy access to the radiator cores for easy cleaning and inspection.

Auto Reversing, Hydraulically Driven Demand Fan (988 only)

The demand fan automatically adjust fan speed for optimal cooling, resulting in reduced power draw on the engine, better fuel efficiency and more power for hydraulics and rimpull. The fan reverses automatically at preset intervals to remove debris from the inlet screen. It can also be reversed manually from the cab.

Component Access

Swing out doors on both sides of the engine compartment provide easy access to the engine oil dipstick and filler spout, S·O·SSM ports, fuel filters air conditioner compressor, engine oil filters, alternators, starting receptacle, air filter service indicator, cooler fill and ether starting aid. There are also ground level viewable sight gauges on all major systems and centralized remote pressure taps.

Shutdown and Lockout Features

An electrical disconnect switch and hydraulic lockout switch allow service technicians to perform maintenance while the machine stays static. Other shutdown or lockout devices include ground level engine shutdown and ground level steering hitch lock lever.





Operator Comfort

Best-in-class working environment

Best-in-Class Working Environment

A comfortable operator is a productive operator, which is why Caterpillar has designed the 988H and 990H with a best in-class working environments for this size wheel loader class.

- Ergonomic controls are fully adjustable and designed for low-effort comfort. Switches and controls for various systems are located within easy reach of the operator.
- Caterpillar Monitoring System (EMS-III) provides information on machine's major components. This includes gauge displays for the fuel tank level; temperature gauges for the engine coolant, torque converter and hydraulic oil; tachometer analog gauge with digital readout for gear selection and ground speed and a monitoring system.
- Optional features are available for improved visibility. These options include a rear vision camera to clearly monitor movement behind the wheel loader and high intensity discharge (HID) lights for greater visibility at night.

Versatility

Work Tool options to meet your needs

Forks and Buckets

Available for both the 988H and 990H, Millyard and Logging Forks are designed to move wood in the millyard. Woodchip Buckets are designed with performance characteristics to bring productivity and fuel efficiency to load-and-carry work in the yard.

- 1 Millyard Forks:** A single top clamp closes down between the tines, allowing individual logs to be picked and placed with ease. An open, high visibility design allows operators to see the job at hand, work faster and more efficiently.
- 2 Logging Forks:** Dual top clamps close down to the tine tips, their curvature maximizes carry capacity. Built to match the task of unloading trucks. An open, high visibility design allows operators to see the job at hand, work faster and more efficiently.
- 3 Woodchip Buckets:** Extra capacity and loading characteristics make this bucket style perfect for handling woodchips. Available in direct pin on models or for use with the Cat Quick Coupler System.
- 4 Cat Full Width Forks:** Dual top clamps are connected to allow maximum capacity while still closing between the tines allowing partial loads to be handled.

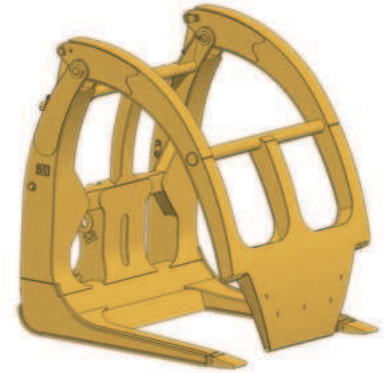

1



2

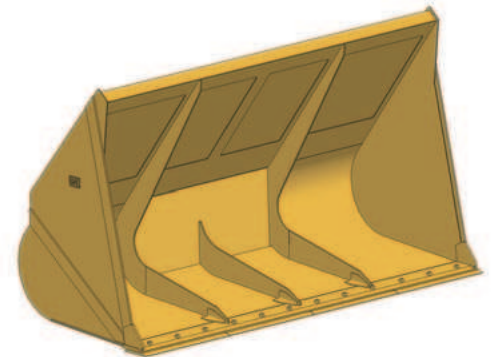

3



4



Customer Support

Count on Cat dealers for business solutions

Selection

Cat dealers can help customers compare and choose the right machine for their business.

Financing

Cat dealers offer financing options to meet a variety of needs.

Operation

Improve operating technique for better productivity and profit with the latest Cat dealer training resources.

Product Support

Cat dealers are with customers every step of the way with unsurpassed worldwide parts support, trained technicians and customer support agreements.

Cat Product Link

Cat Product Link enables convenient remote monitoring of equipment. Get usable information to keep jobs on schedule, maintain machine health and reduce fleet owning and operating costs.

- Simplify fleet management and monitor machine use
- Link all machines regardless of brands
- Three levels of insight to meet specific business requirements.

Operating Specifications – 988H

Attachment Type	Cat Logging Forks	
Hinge Pin Height, Unloaded	4909 mm	16.11 ft
Overall Length	12 465 mm	40.90 ft
Turning Radius at SAE Carry	9253 mm	30.36 ft
Tipping Load:		
Straight	34 338 kg	75,702 lb
Articulated 37°	29 819 kg	65,740 lb
Operating Weight	58 330 kg	128,328 lb

Engine – 988H

Engine Model	Cat® C18 ACERT™	
Gross Power	414 kW	555 hp
Net Power – ISO 14396	393 kW	532 hp
Net Power – EEC 80/1269	373 kW	501 hp
Net Power – ISO 9249	373 kW	501 hp
Gross Power – ISO 3046-2	388 kW	520 hp
Bore	145 mm	5.7 in
Stroke	183 mm	7.2 in
Displacement	18.1 L	1,104.5 in ³

Transmission – 988H

Converter Drive – Forward 1	6.7 km/h	4.2 mph
Converter Drive – Forward 2	11.8 km/h	7.3 mph
Converter Drive – Forward 3	20.8 km/h	12.9 mph
Converter Drive – Forward 4	36 km/h	22.3 mph
Converter Drive – Reverse 1	7.6 km/h	4.7 mph
Converter Drive – Reverse 2	13.5 km/h	8.4 mph
Converter Drive – Reverse 3	23.7 km/h	14.7 mph
Direct Drive – Forward 1	Lock-up disabled	
Direct Drive – Forward 2	12.3 km/h	7.7 mph
Direct Drive – Forward 3	21.9 km/h	13.6 mph
Direct Drive – Forward 4	38.6 km/h	24 mph
Direct Drive – Reverse 1	7.9 km/h	4.9 mph
Direct Drive – Reverse 2	14.1 km/h	8.8 mph
Direct Drive – Reverse 3	25.1 km/h	15.6 mph

Axles – 988H

Maximum Single – Wheel Rise and Fall	568 mm	22.4 in
Front	Fixed	
Rear	Oscillating ±13°	

Brakes

Brakes	Meet SAE/ISO 3450:1996
--------	------------------------

Steering – 988H

Steering	Meets SAE and ISO standards
Total Steering Angle	74 Degrees

Cab

Cab – ROPS/FOPS	Meets SAE and ISO standards
Sound Performance	Meets ANSI, SAE and ISO standards

Service Refill Capacities – 988H

Fuel Tank	712 L	188 gal
Cooling System	103 L	27.2 gal
Crankcase	60 L	15.9 gal
Transmission	70 L	18.5 gal
Differentials and Final Drives – Front	186 L	49 gal
Differentials and Final Drives – Rear	186 L	49 gal
Hydraulic System (factory fill)	470 L	124.2 gal
Hydraulic System (tank only)	267 L	70.5 gal

988H/990H Specifications

Operating Specifications – 990H

Attachment Type	Cat Millyard Forks	
Hinge Pin Height, Unloaded	5866 mm	19.25 ft
Overall Length	13 659 mm	44.81 ft
Turning Radius at SAE Carry	10 096 mm	33.12 ft
Tipping Load:		
Straight	40 059 kg	88,315 lb
Articulated 37°	35 289 kg	77,799 lb
Operating Weight	89 963 kg	198,334 lb

Engine – 990H

Engine Model	Cat® C27 ACERT™	
Gross Power	512 kW	687 hp
Flywheel Power	468 kW	627 hp
Net Power – EEC 80/1269	468 kW	627 hp
Net Power – ISO 9249	468 kW	627 hp
Gross Power – ISO 3046-2	468 kW	627 hp
Bore	137 mm	5.4 in
Stroke	152 mm	6 in
Displacement	27.1 L	1,666 in ³

Transmission – 990H

Converter Drive – Forward 1	7 km/h	4.3 mph
Converter Drive – Forward 2	12.1 km/h	7.5 mph
Converter Drive – Forward 3	20.8 km/h	12.9 mph
Converter Drive – Reverse 1	7.7 km/h	4.8 mph
Converter Drive – Reverse 2	13.4 km/h	8.3 mph
Converter Drive – Reverse 3	22.8 km/h	14.2 mph
Direct Drive – Forward 1	Lock-up disabled	
Direct Drive – Forward 2	12.8 km/h	7.9 mph
Direct Drive – Forward 3	22.4 km/h	13.9 mph
Direct Drive – Reverse 1	7.9 km/h	4.9 mph
Direct Drive – Reverse 2	14.1 km/h	8.8 mph
Direct Drive – Reverse 3	24.8 km/h	15.4 mph

Axles – 990H

Maximum Single – Wheel Rise and Fall	572 mm	22.5 in
Front	Fixed	
Rear	Oscillating	
Oscillation Angle	±11°	

Brakes

Brakes	Meet SAE/ISO 3450:1996
--------	------------------------

Steering – 990H

Steering	Meets SAE and ISO standards
Total Steering Angle	70 Degrees

Cab

Cab – ROPS/FOPS	Meets SAE and ISO standards
Sound Performance	Meets ANSI, SAE and ISO standards

Service Refill Capacities – 990H

Fuel Tank	1074 L	284 gal
Cooling System	190 L	50.2 gal
Crankcase	95 L	25 gal
Transmission	110 L	29 gal
Differentials and Final Drives – Front	271 L	71.6 gal
Differentials and Final Drives – Rear	261 L	68.9 gal
Hydraulic System (tank only)	174 L	45.97 gal
Hydraulic System – Lift/Tilt and Brakes	435 L	113 gal
Hydraulic System – Steering and Engine Cooling Fan	194 L	50.5 gal
Hydraulic System (including tank)	435 L	114.91 gal

Dimensions – 988H

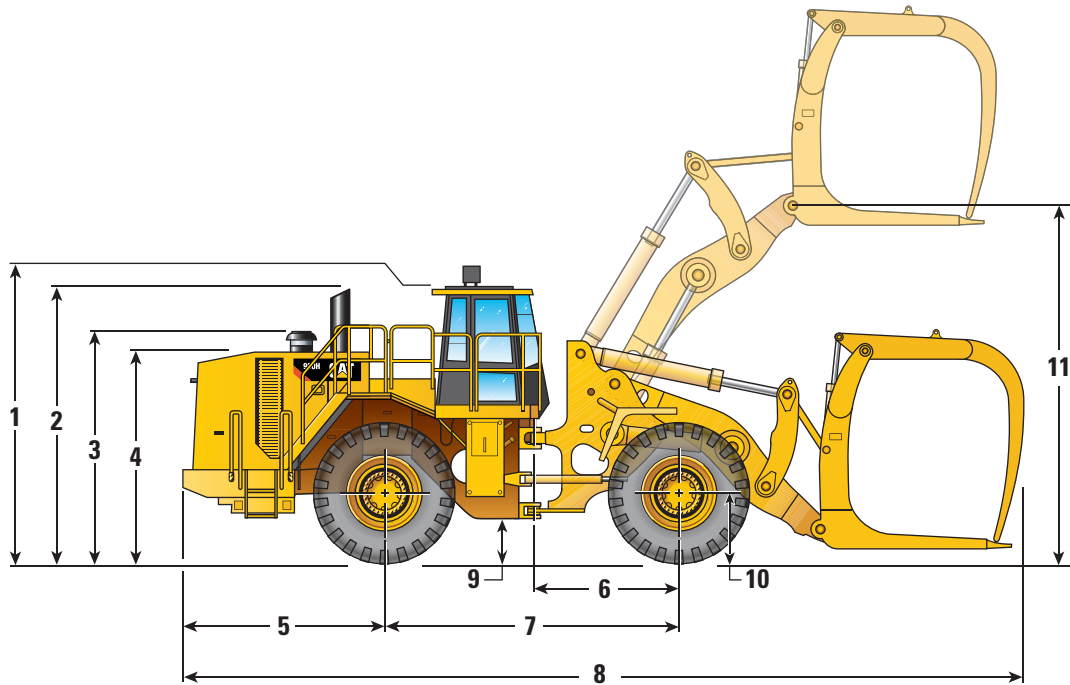

1	Height to Top of Cab	4105 mm	13 ft 6 in
2	Height to Top of Exhaust Stacks	4089 mm	13 ft 5 in
3	Height to Top of Air Cleaner	3359 mm	11 ft 0 in
4	Height to Top of Hood	3133 mm	10 ft 3 in
5	Center Line of Rear Axle to Edge of Rear Bumper	3132 mm	10 ft 3 in
6	Center Line of Front Axle to Hitch	2275 mm	7 ft 6 in
7	Wheel Base Length	4550 mm	14 ft 11 in
8	Length with Forks on Ground	12 464.6 mm	40 ft 11 in
9	Ground Clearance	526 mm	1 ft 9 in
10	Height to Center of Wheel	955 mm	3 ft 2 in
11	Hinge-Pin Height	4909 mm	16 ft 1 in

988H/990H Specifications

Dimensions – 990H

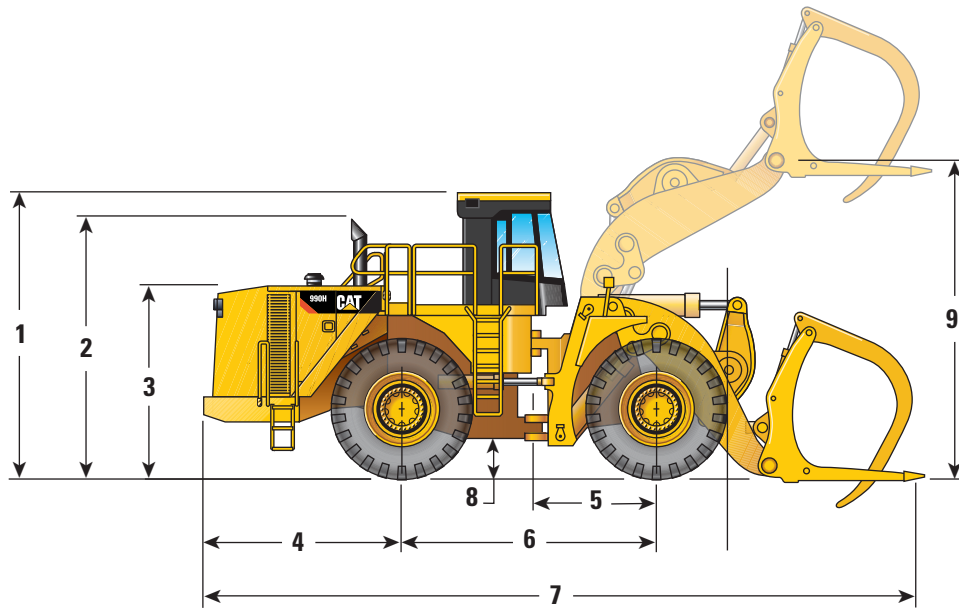

1	Height to Top of Cab	5070 mm	16 ft 8 in
2	Height to Top of Exhaust Stacks	4726 mm	15 ft 6 in
3	Height to Top of Hood	3515 mm	11 ft 6 in
4	Center Line of Rear Axle to Edge of Rear Bumper	3615 mm	11 ft 10 in
5	Center Line of Front Axle to Hitch	2300 mm	7 ft 7 in
6	Wheel Base Length	4600 mm	15 ft 1 in
7	Length with Forks on Ground	13 369.6 mm	43 ft 10 in
8	Ground Clearance	478 mm	19 in
9	Hinge-Pin Height	5866 mm	19 ft 3 in

988H/990H Large Wheel Loader Millyard Arrangements

For more complete information on Cat products, dealer services, and industry solutions, visit us on the web at www.cat.com

© 2011 Caterpillar Inc.
All rights reserved

Materials and specifications are subject to change without notice. Featured machines in photos may include additional equipment. See your Cat dealer for available options.

CAT, CATERPILLAR, SAFETY.CAT.COM, their respective logos, "Caterpillar Yellow" and the "Power Edge" trade dress, as well as corporate and product identity used herein, are trademarks of Caterpillar and may not be used without permission.

AEHQ6379 (11-2011)

