

# 988H

## Wheel Loader



### Engine

Engine Model	Cat® C18 ACERT®	
Gross Power	414 kW	555 hp
Flywheel Power	373 kW	501 hp

### Operating Specifications

Operating Weight	49 546 kg	109,249 lb
Rated Payload	11.4 tonnes	12.5 tons

### Buckets

Bucket Capacities	6.3 m <sup>3</sup> –7.0 m <sup>3</sup>	8.2 yd <sup>3</sup> –9.2 yd <sup>3</sup>
-------------------	--	--



# 988H Wheel Loader

*Improved performance and rugged durability combine with operator comfort for maximum productivity.*

---

## Structures and Fabricated Box Boom

The articulated frame design features a high-torsion, compact, load-absorbing, front frame and a large, box-section, engine-end frame. Fabricated boom and linkage geometry increase dump clearance, provide improved breakout and lift forces and increase the viewing area to the bucket corners. **pg. 4**

---

## Application Truck Match

Increased performance and good pass matching make the 988H a versatile performer. **pg. 14**

*Revolutionary design, Caterpillar® quality. Electro-hydraulic controls, increased power and torque rise, front linkage and unmatched operator comfort work together for increased performance and added durability to make the 988H an innovative, 21st Century large wheel loader geared for maximum production in the toughest conditions.*

---

## Power Train

- ✓ The Cat C18 engine with ACERT® Technology is U.S. EPA Tier 3/EU Stage III compliant. The Cat transmission and impeller clutch torque converter offer smooth, consistent shifting with fingertip control. Electronic controls help increase productivity. **pg. 6**

---

## Maintenance and Serviceability

Most daily maintenance checks are performed from the machine's left side, facilitating quick start up. Case drain filters for main hydraulic, steering and fan pumps protect against contamination, and remote pressure taps contribute to improved serviceability. Easy access to major components enhance serviceability and increase uptime. **pg. 15**

---

## Hydraulics and Electronic Monitoring

Innovative electro-hydraulics play a key role in performance of the 988H and provide lower operator effort. Increased hydraulic efficiency improves lift and tilt cycle time for reduced overall cycle time. The tradition of reliable, high-performance Cat hydraulics continues. **pg. 8**



---

### Operator Station

Experience a high level of efficiency, comfort and productivity with one-hand STIC operation, a large cab, low-effort fingertip lift and tilt controls, improved operator visibility, reduced sound levels, improved ventilation and easier entry and exit. **pg. 10**

---

### Buckets and Ground Engaging Tools (GET)

Choose between 6.3 m<sup>3</sup> (8.2 yd<sup>3</sup>) and 7.0 m<sup>3</sup> (9.2 yd<sup>3</sup>) capacity buckets, spade edge and straight edge buckets and various GET to match job conditions. Cat buckets retain the proven shell-tine construction design for unmatched durability. **pg. 12**

---

### Bucket Match

Improve machine performance and increase stability by selecting the right bucket for your application and material density. **pg. 13**

---

### Customer Support

Your Cat dealer offers a wide range of services that help you operate longer with lower costs. **pg. 16**



✓ *New Feature*

## Structures and Fabricated Box Boom

*Superior design of structures, along with the bold, box-section front linkage provide superior strength.*



**Structures.** Combine the use of robotic welding and castings in critical high-stress areas. More than 90 percent of the 988H structure is robotically welded to provide highly consistent welds and increased strength. Castings are also used in several areas to increase strength by helping to spread the loads and reduce the number of parts.

**1 Full Box-Section Frame.** Has been improved for maximum strength and minimum weight. The frame rail is now extended further forward, improving rail to hitch strength.

**2 Box-Shaped Tower.** Is designed for improved resistance to twisting for maximum strength. The tilt cylinder tower's high-strength steel plates direct stress down to the lift cylinder case mounting tube, absorbing impact and loading forces. This design results in a narrower tower which gives a better operator viewing area.



**3 Upper and Lower Hitch Pins.** Pivot on double-tapered roller bearings. The hitch plates are shaped to direct stress away from the end of the weld, resulting in a smoother transition of stress loads into the frame.

**4 Spread-Hitch Design.** Increases the spread 26 percent to help square-up the frame and provide increased clearance for access to the hitch and hydraulic lines.

**5 Steering Cylinder Mounts.** Are located on the axle pads to provide efficient transfer of steering loads to the axle.

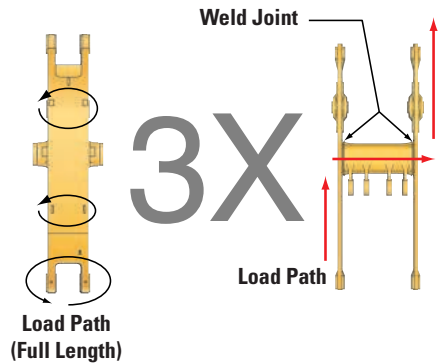

**6 Fabricated Box Boom.** Replaces the traditional steel plate lift arms found on wheel loaders. This design features forked ends for easier service, faster assembly and increased reliability. Castings in high stress areas smooth the transition of stress distribution for excellent service life. The boom and dual bucket links work together for increased breakout force, better torsional resistance and higher lift capacity.



**Fabricated Boom Box-Section Design.**

Has more torsional stiffness than a Z-bar design. With the parallel lift arm design, corner loading the bucket sends stresses up the lift arm, through the cross tube welding and up the other lift arm. The box-section design spreads stresses over the full length and perimeter of the boom, allowing stress transfer through parent material. This resists twisting and prevents stress paths that can lead to cracking.

## Power Train

*The Cat power train delivers top performance and durability in tough applications. Changes to the aftercooler, injectors, bearings and pistons help improve startability, response, power, emissions and fuel consumption.*

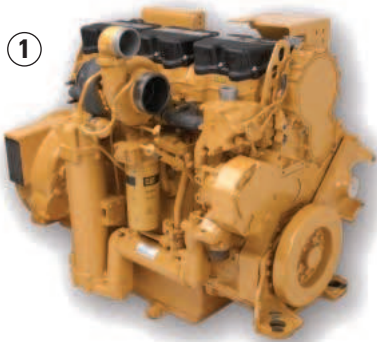
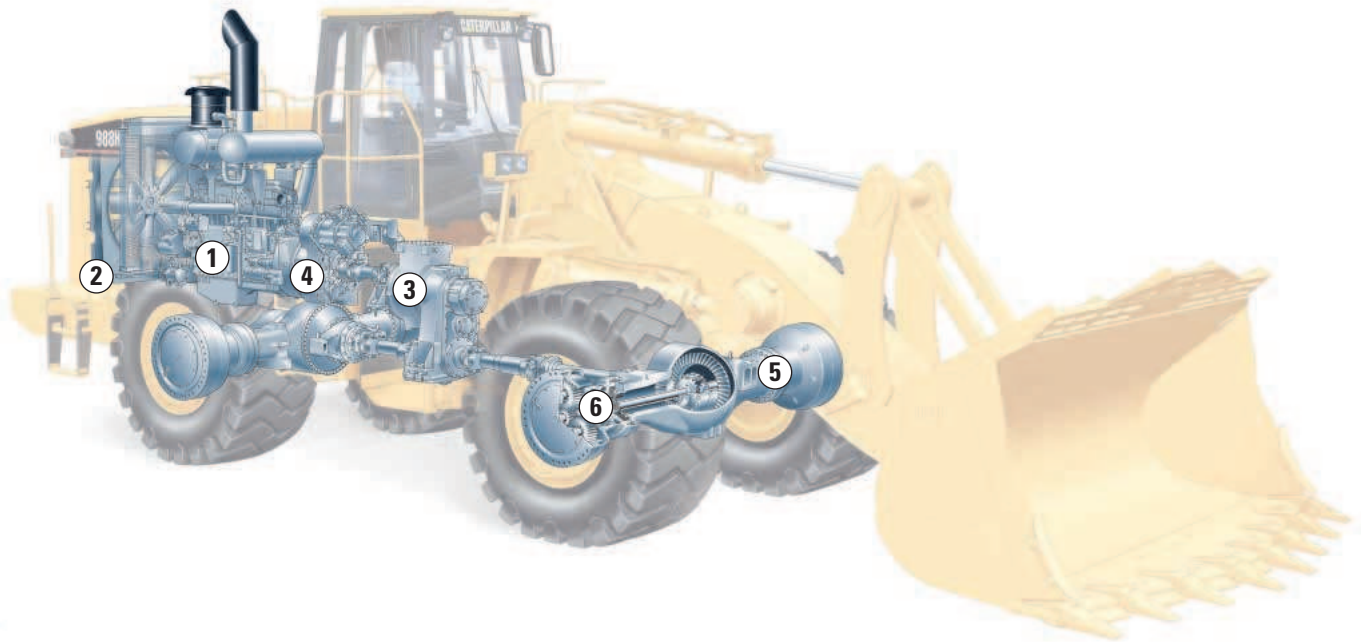

### 1 Cat C18 Engine with ACERT®

**Technology.** Is U.S. EPA Tier 3 and EU Stage III compliant. It features increased horsepower and efficient fuel management for quick response, high productivity and exceptional service life. A new, sculptured cylinder block provides greater strength and lighter weight.

**Mechanically Actuated, Electronic Unit Injection (MEUI).** Proven high-pressure, direct injection fuel system electronically monitors operator demands and sensor inputs to optimize engine performance.

**Air Cleaners.** Are dry-type radial seal with primary and secondary elements and precleaner.

**ADEM™ IV.** Controls the fuel injector solenoids to monitor fuel injection. This system provides automatic altitude compensation, air filter restriction indication and it will not allow the engine to fire until it has oil pressure, acting as cold start protection and a form of pre-lube.

### Air-to-Air Aftercooler (ATAAC).

Provides a separate cooling system for the intake manifold air. The ATAAC system routes hot, compressed air from the turbo and cools it with a single pass, air-to-air aluminum heat exchanger. The cooled compressed air greatly reduces the emissions produced, meeting the EPA Tier 3/EU Stage III requirements.

### 2 Separate Engine Cooling System.

Isolates the radiator and fan from the engine compartment for more efficient cooling and allows for a sloped hood for an increased viewing area.

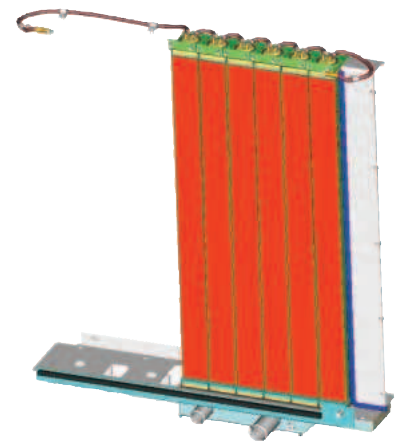

### Next Generation Modular Radiator

**(NGMR).** Improves cooling capabilities by using a parallel flow system with six cores. Serviceability is improved with NGMR since there is no top tank to remove.

### 3 Electronically Controlled Cat Planetary Power Shift Transmission.

Features perimeter-mounted, large diameter clutch packs that control inertia for smooth shifting and increased component life.

**Demand Fan.** The Cat C18 electronic engine continuously gathers information to control the demand fan speed and provides constant net horsepower regardless of operating conditions. This compensates for varying fan loads and enables the machine to maintain normal system temperatures and reduce fuel consumption.

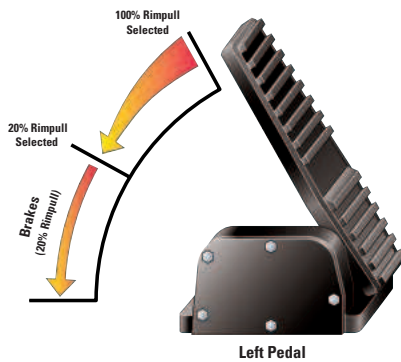

**4 Impeller Clutch Torque Converter (ICTC).** Combined with the Rimpull Control System (RCS) allows the operator maximum flexibility in modulating rimpull.

- Calibration procedure improved.
- Left pedal modulation improved.
- Wear compensated for by providing the ability to recalibrate for optimum left pedal modulation regardless of torque converter wear.
- Left brake pedal modulates rimpull from 100 to 25 percent for reduced tire slippage and wear. After 25 percent is achieved, further pedal travel applies the brake.

- RCS allows operator to select from four preset maximum rimpull settings, other than 100 percent, that are available in first gear (90, 80, 70 and 60 percent).
- A lock-up clutch torque converter provides direct drive efficiency. Translates into improved fuel efficiency in certain applications.

**Final Drives.** Feature planetary reduction at each wheel. Torque is developed at the wheel, which offers less stress at the axle shafts. The planetary units can be removed independently from the wheels and brakes.

**5 Heavy-Duty Axles.** Feature optional axle oil coolers, permanently lubed universal joints and stronger axle components in both the differentials and final drives for increased performance, serviceability and durability. Conventional differential is standard.

**Free-Floating Axle Shafts.** Can be removed independent of the wheels and planetaries for quick and easy serviceability.

**Optional Axle Oil Cooling System.** Features two circuits that circulate oil from the differentials through an oil-to-air cooler and filter and back to the brakes. This system provides increased oil life and improves component performance and durability. The system automatically turns on and off at a preset oil temperature.

#### **6 Axle-Shaft, Oil Disc Brakes.**

Are adjustment-free, fully hydraulic and completely sealed. Disc face grooves provide cooling even when brakes are applied for long, fade-resistant service life.

- Location of the brakes improves serviceability. The axle shaft brake design allows brake service while leaving the final drive intact.
- Axle-shaft brakes require less force by operating on the low torque side of the axle. Combined with improved axle oil circulation for increased cooling, the oil-enclosed, multiple-disc brake design improves durability.
- Parking brake is spring-applied, oil-released and dry disc. It is mounted on the transfer gear output shaft. Manual override is possible to allow movement of the machine.

**Secondary Brakes.** Are fully modulated and the front and rear service brake circuits are isolated so one circuit can operate if pressure drops in the other circuit.

**Service Brakes.** Are four-wheel, hydraulic, oil-dipped, multiple disc brakes that are adjustment-free, completely enclosed and allow modulated engagement without slack adjusters.



## Hydraulics and Electronic Monitoring

*Efficient, well-balanced hydraulics and low-effort electronic controls mean high performance and exceptional durability.*

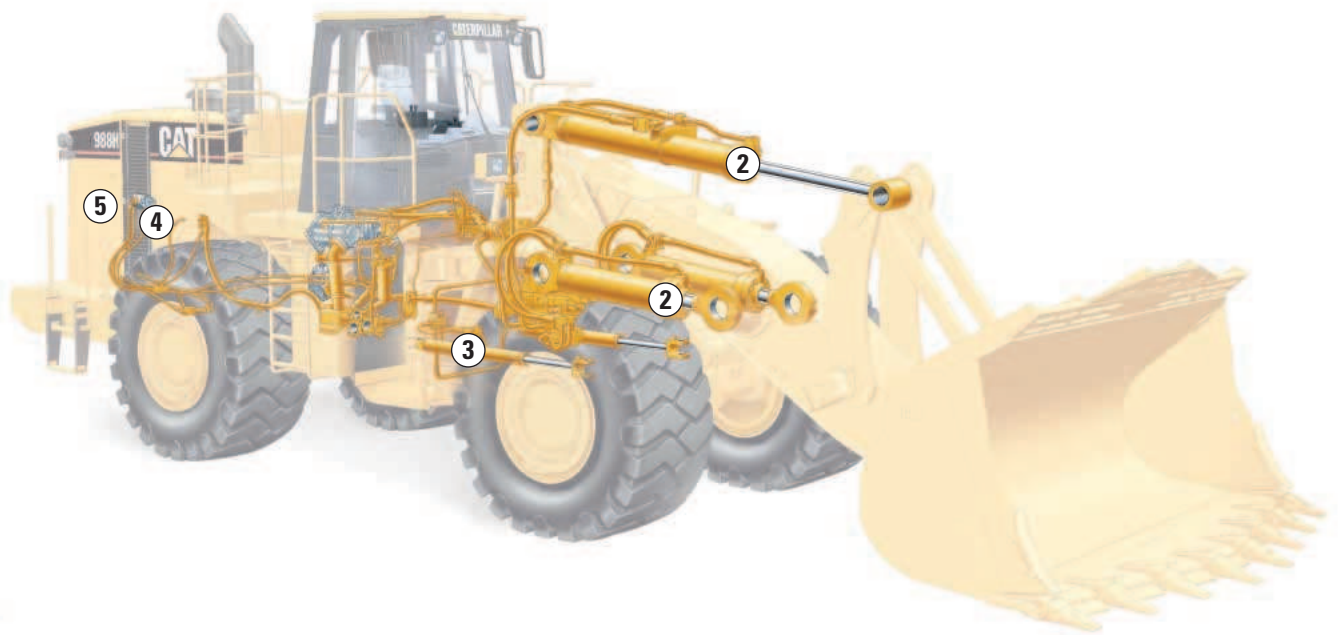

### **1 Electro-Hydraulic Control System.**

Increases hydraulic efficiency and enhances operator comfort through low-effort, fingertip controls. XT-3™ and XT-5™ hose along with reliable components reduce the risk of leaks and blown lines, helping protect the environment.

**2 Lift and Tilt System.** Consists of larger bore lift and tilt cylinders and a two position main hydraulic pump, contributing to increased performance and serviceability.

### **Two Position Main Hydraulic Pump.**

Is controlled by the Electronic Control Module (ECM). A solenoid valve controls the pump displacement, allowing the ECM to adjust hydraulic flow during the loader cycle. This strategy results in fast hydraulics and greater lift forces, leading to optimized performance.

**3 Load Sensing Steering.** The STIC control system integrates the steering and transmission into a single controller. A STIC operated, pilot valve controls the flow to steering cylinders. The steering system utilizes a variable displacement pump for maximum machine performance by directing power through the steering system only when needed.

**4 Case Drain Filtration.** A total of three filters for the main hydraulic, steering and fan pumps protect against contamination with easy access for service.





**5 Demand Fan.** A speed controlled, hydraulic fan provides maximum cooling efficiency by directing the appropriate amount of power through the fan system based on the system's temperature.

**Advanced Electronics.** Play a major role in the operation of the 988H. Productivity improvements, enhanced serviceability, increased operator efficiency and lower costs are direct benefits of the 988H advanced electronics.

**6 Caterpillar Monitoring System (EMS-III).** Continually monitors various machine systems through three instrument clusters and provides a three-level warning system to alert the operator of immediate or pending problems. It shares information with the engine, hydraulic and transmission controls that can be used during servicing to simply service and troubleshooting. The Caterpillar Monitoring System also allows for new software to be uploaded directly into the cab.

**Optional Payload Control System.**

Tracks data regarding the load in the bucket. It also features a numeric keypad and easy to view display. An available printer makes onboard ticket printing possible.

**Optional Ride Control.** Provides a boom suspension system by placing two accumulators in the boom circuit, reducing fore and aft pitch over rough terrain. This results in a smoother, more comfortable ride, allowing higher load and carry speeds, increased load retention and component life.

**Loose Material Mode.** Provides maximum hydraulic speed and efficiency for loading in easily penetrated loose material.

## Operator Station

*An industry standard for comfort and efficiency.*



**World Class Cab.** Over 3.18 m<sup>3</sup> (112 ft<sup>3</sup>) of volume incorporates innovations for operator comfort, maneuverability and productivity. Features include outstanding

viewing area, excellent cab ventilation, interior sound levels below 77 dB(A), standard coat hook, cup holder, storage bin, intermittent wet-arm wipers, room

for a large lunch cooler and radio and Cat Product Link ready.



**1 STIC Control System.** Combines gear selection and steering into one control lever that requires less effort and provides smooth shifting. Side-to-side motions for steering, finger operator direction control and thumb operator buttons for gear selection combine to provide a fluid motion that reduces effort and allows the operator to work the machine for long periods of time with little or no fatigue.

**2 Left Pedal.** Operates the impeller clutch torque converter/braking while the right pedal operates standard braking.

**3 Cat Comfort Seat.** An ergonomic design with thick foam in key parts of the seat back, thick seat cushions and an automotive-style lumbar support translates into great operator comfort, reduced fatigue and consistent productivity throughout the work shift. The six-way adjustable, air suspension seat has a retractable seatbelt, headrest and adjustable armrests for optimum comfort.

**4 Electro-Hydraulic Controls and Armrests.** Provide low effort, fingertip control for enhanced comfort and stability.

Floor-mounted controls and armrests are fore, aft and height adjustable to accommodate operators of any size in a comfortable operating position.

**5 Caterpillar Monitoring System (EMS-III).** Provides information on machine's major components and systems.

- Gauge displays fuel tank level and temperatures for engine coolant, torque converter and hydraulic oil. Tachometer is an analog gauge with digital readout for gear selection and ground speed.
- Alerts operator if transmission is engaged while parking brake is applied. If pressure drops, the parking brake applies automatically.



Main module consists of 10 fault indicators and one display panel. If any critical engine condition is detected, the engine will derate power.

**6 Throttle Lock.** Allows operator to pre-set the engine speed for a variety of applications, resulting in faster cycle times and increased productivity.

**7 Rimpull Control System (RCS).** Has four factory preset, reduced rimpull settings (90, 80, 70 and 60 percent of rimpull). Reduced rimpull settings can be modified by your Cat dealer to better match ground conditions.

**8 Rimpull Control System (RCS) Switch.** Turns RCS on and off.

**9 Kickout Positioner Control.** Allows the operator to set customized upper, lower and bucket dig angle kickouts for maximum operating efficiency.

**10 Optional Ride Control Switch.** Turns ride control to off or automatic position.

**11 Autoshift.** Allows the operator to set the maximum gear into which the transmission will be allowed to shift. This feature contributes to additional comfort and focus on the job. The switch also offers a manual position for operator controlled shifting.

**12 Optional Lock-up Clutch Torque Converter Switch.** Activates the lock-up clutch for direct drive efficiency.

**13 Loose Material Operating Mode.** Tailors hydraulics to provide maximum loose material loading efficiency.

**14 Front and Rear Window Wiper/Washer.** Are within easy reach to help maintain a clear field of vision.

**15 Viewing Area.** Bonded front windshield eliminates distracting metal frames for excellent bucket and work site operator visibility. An internal ROPS improves peripheral viewing by eliminating the large structure outside the cab.

**16 Electro-Hydraulic Lock-out Switch.** Disables hydraulic controls.

**17 Optional Reversible Fan.**

**18 Optional Hazard Lights.**

**19 Optional Rotary Beacon.**

**20 Optional Autolube.**



## Buckets and Ground Engaging Tools (GET)

*Cat buckets and GET provide the flexibility to match the machine to your application.*

**Buckets.** Ranging from 6.3 m<sup>3</sup> (8.2 yd<sup>3</sup>) to 7.6 m<sup>3</sup> (10 yd<sup>3</sup>) may be configured for a variety of impact and abrasive conditions. All buckets are built with shell-tine construction (1) that resist twisting and distortion and feature replaceable, weld-on wear plates to protect the bottom of the bucket. The integral rock guard (2) helps retain large loads while heavy-duty pins and retainers (3) provide durability.

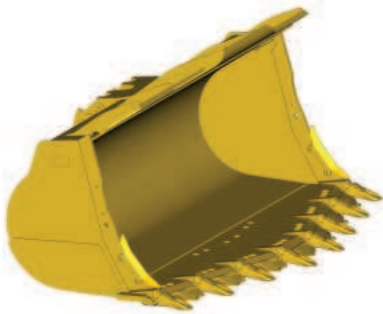

**Spade Edge Rock Buckets.** With bolt-on segments, are available in 6.4 m<sup>3</sup> (8.33 yd<sup>3</sup>), 6.9 m<sup>3</sup> (9.0 yd<sup>3</sup>) and 7.6 m<sup>3</sup> (10 yd<sup>3</sup>). Each accepts up to two sets of sidebar protectors (4), feature shouldered, double-strap adapters, easily changed bolt-on segments and several tip options.



**Straight Edge Buckets.** Are available in 6.3 m<sup>3</sup> (8.2 yd<sup>3</sup>) Straight Edge Rock as well as 7.0 m<sup>3</sup> (9.2 yd<sup>3</sup>) and 7.6 m<sup>3</sup> (10 yd<sup>3</sup>) General Purpose configurations. The Straight Edge Rock bucket features double strap adapters and accepts two sets of sidebar protectors, bolt-on segments and tips. The General Purpose bucket is available with bolt-on cutting edge, bolt-on adapters or bolt-on adapters with segments.

**High Abrasion Bucket.** Is available with 6.4 m<sup>3</sup> (8.33 yd<sup>3</sup>) capacity and is recommended for use in face loading where high abrasion and moderate impact is encountered. This bucket features additional wear protection items including independently attached edge and adapter covers, additional liners and wear plates, one set of sidebar protectors and a thicker base edge.

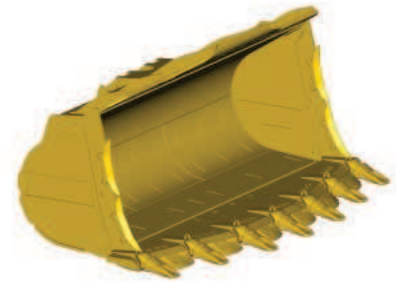

**Heavy Duty Quarry Bucket.** Is available as a 6.4 m<sup>3</sup> (8.33 yd<sup>3</sup>) capacity bucket and is recommended for use in face loading where moderate abrasion and high impact is encountered. It features additional wear protection items including four sidebar protectors (4), thicker base edge and adapters (5), additional liners and wear plates (6) and bolt-on half arrow segments (7).

**Bucket Controls.** Feature electro-hydraulic lift and tilt circuits for lower lever effort.

**Lift Circuit.** Has four positions: raise, hold, lower and float and can adjust automatic upper and lower kickouts from the cab.

**Tilt Circuit.** Features three positions: tilt back, hold and dump. It can adjust automatic bucket positioner to desired loading angle from the cab and does not require visual spotting.

**Mechanically Attached Wear Plates (MAWP).** Are available as a Custom attachment.

# Bucket Match

*Proper bucket and application match deliver increased stability and peak performance.*

**Buckets and GET.** The 988H offers a variety of bucket types and available GET configurations to properly configure the machine based on material density, impact and abrasion.

Depending on your material densities, the 988H has available a 6.4 m<sup>3</sup> (8.33 yd<sup>3</sup>) Spade Nose bucket with teeth and bolt-on segments for improved performance and edge protection.

Increased full turn static tipping load, horsepower and hydraulic capabilities allow the 988H to effectively utilize the 6.6 m<sup>3</sup> (8.7 yd<sup>3</sup>) and 6.9 m<sup>3</sup> (9.0 yd<sup>3</sup>) bucket size in lighter materials such as limestone.

To better match your 988H to material conditions, contact your Cat dealer for specialty bucket needs.



## Bucket Selection Guide and Matrix

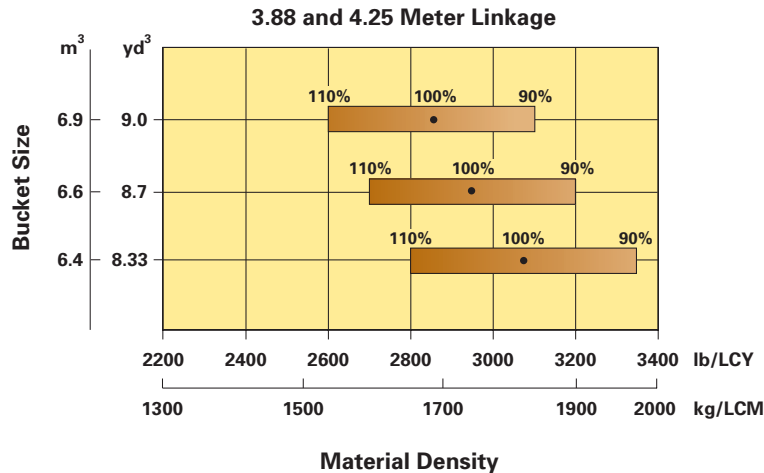

**NOTE:** Percentages shown represent bucket fill factor  
 ● - Center point at 100% fill

Changes in bucket weight, including field installed wear iron, can impact rated payload. Consult your Caterpillar dealer for assistance in selecting and configuring the proper bucket for the application. The Caterpillar Large Wheel Loader Payload Policy is a guideline intended to maximize wheel loader structural and component life.

## Application Truck Match

*Matched payloads and matched buckets ensure optimum performance.*



**Performance.** The 988H is an aggressive first gear loader for face and bank excavation. With increased dump clearance, the 988H can easily load 37-63 tonnes (40-70 ton) off-highway trucks. Increased performance and good pass match make the 988H a versatile performer with a cost per ton that will help your bottom line.

The versatility of a material handler is designed into this wheel loader. With balanced rimpull and hydraulics, the 988H is an aggressive loader and gets the job done quickly and efficiently in loose or stock-pile material and in load and carry work.

## Large Wheel Loader/Truck Application Match

988H Rated Payload: 11.4 metric ton (12.5 short ton)

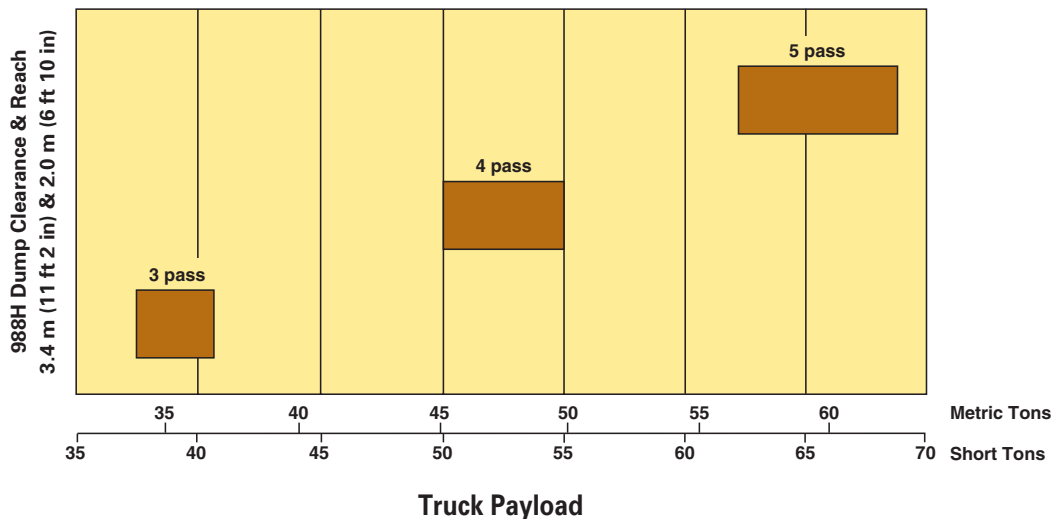

- 769D = 36 Metric Tons (40 Short Ton) nominal payload
- 771D = 41 Metric Tons (45 Short Ton) nominal payload
- 773E = 54 Metric Tons (60 Short Ton) nominal payload
- 775E = 63 Metric Tons (70 Short Ton) nominal payload



## Maintenance and Serviceability

*Easier maintenance and enhanced serviceability give you more time in the pile.*

**Maintenance and Repair.** Is easier through monitoring key functions and logging critical indicators. Electronic diagnostic access is possible with a single tool, the Cat Electronic Technician (ET). In addition to the servicing features built into the engine, the 988H includes:

- **Daily Maintenance Checks.** Most can be performed from the left side of the machine, making it part of an easy pre-start routine. Routine maintenance promotes long service life and durability.

- **Next Generation Modular Radiator (NGMR).** Allows service technicians to replace individual cores for enhanced serviceability. Maintenance is also simplified since NGMR is isolated from the engine compartment.

- **U-joints and Slipshaft.** Are permanently lubricated.

- **Lube Points.** Are centralized in accessible locations. Fuel fill is located on the left side. Both lube points and fuel fill are accessible from ground level, making lube and fuel service quicker and easier.

- **Swing-out Doors.** On both sides of the engine compartment provide easy access to the engine oil dipstick and filler spout, S-O-S<sup>SM</sup> port, fuel filters, air conditioner compressor, engine oil filters, alternator, starting receptacle, air filter service indicator, coolant fill and ether starting aid. The disconnect switch and diagnostic connectors are located on the rear platform.

- **Hinged Doors.** In the platform provide access to the hydraulic tank fill, lift and tilt and steering filters. The transmission sight glass and filler spout are serviced from the hitch area.



- **Case Drain Filters.** Protect the hydraulic system from contamination and are conveniently located behind the cab in the service platform.

- **Batteries (1,000 CCA).** Sit in a built-in battery box and are accessible through tread plates on the right platform.

- **Shock Resistant Lights.** Are replaceable by hand, not requiring the use of any tools.

- **Caterpillar Monitoring System (EMS-III).** Provides operators and service technicians with diagnostic information on the machine's major components and systems. It also allows for a flashable software using a laptop and Cat ET instead of replacing a chip that contains the new software.

- **Remote Mounted ECPC Pressure Taps.** Are easily accessible behind the cab under the platform.

- **500 Hour Oil Change Interval.** Uptime and production are increased with a longer time between engine oil changes.

## Customer Support

*Cat dealer services help you operate longer with lower costs.*



**Machine Selection.** Make detailed comparisons of the machines under consideration before purchase. Cat dealers can estimate component life, preventive maintenance cost and the true cost of lost production.

**Purchase.** Look past initial price. Consider the financing options available as well as the day-to-day operating costs. Look at dealer services that can be included in the cost of the machine to yield lower equipment owning and operating costs over the long run.

### **Customer Support Agreements.**

Cat dealers offer a variety of product support agreements and work with customers to develop a plan that best meets specific needs. These plans can cover the entire machine, including work tools, to help protect the customer's investment.

**Product Support.** You will find nearly all parts at our dealer parts counter. Cat dealers use a world-wide computer network to find in-stock parts to minimize machine down time. Save money with genuine Cat Remanufactured parts. You receive the same warranty and reliability as new products but at a cost savings of 40-70 percent.

**Operation.** Improving operator techniques can boost your profits. Your Cat dealer has training videotapes, literature, classes and other ideas to help you increase productivity.

**Maintenance Services.** More and more equipment buyers are planning for effective maintenance before buying equipment. Choose from your dealer's wide range of maintenance services at the time you purchase your machine. Repair option programs guarantee the cost of repairs up front. Diagnostic programs such as S-O-S<sup>SM</sup> and Coolant Sampling and Technical Analysis help you avoid unscheduled repairs.

**Replacement.** Repair, rebuild or replace? Your Cat dealer can help you evaluate the cost involved so you can make the right choice.

## Engine

Engine Model	Cat C18 ACERT®	
Gross Power	414 kW	555 hp
Flywheel Power	373 kW	501 hp
Net Power – EEC 80/1269	373 kW	501 hp
Net Power – ISO 9249	373 kW	501 hp
Gross Power – ISO 3046-2	388 kW	520 hp
Bore	145 mm	5.7 in
Stroke	183 mm	7.2 in
Displacement	18.1 L	1,104.5 in <sup>3</sup>

- These ratings apply at 1,800 rpm when tested under the specific standard conditions for the specified standard.
- Power rating conditions based on standard air conditions of 25° C (77° F) and 99 kPa (29.32 in Hg) dry barometer, using 35° API gravity fuel having an LHV of 42 780 kJ/kg (18,390 Btu/lb) when used at 30° C (86° F) [reference a fuel density of 838.9 g/L (7.001 lb/gal)].
- Net power advertised is the power available when the engine is equipped with alternator, air cleaner, muffler and hydraulic fan drive.
- No derating required up to 3048 m (10,000 ft) altitude.
- Direct-electric, 24-volt starting system with 100 amp alternator and four high performance maintenance-free batteries with 1,000 cold cranking amps.

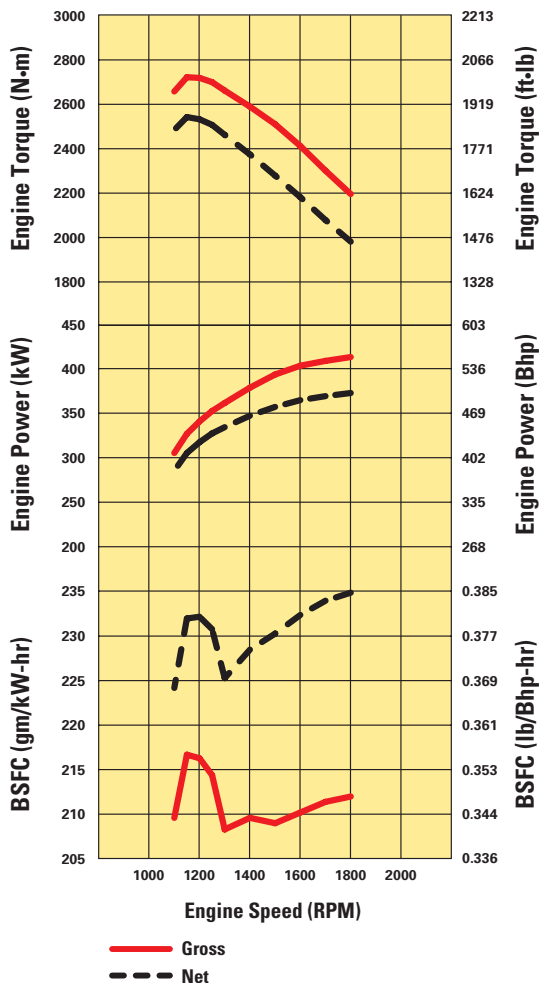

## Operating Specifications

Rated Payload	11.4 tonnes	12.5 tons
Operating Weight	49 546 kg	109,249 lb
Rated Payload – Standard	11.4 tonnes	12.5 tons

## Transmission

Converter Drive – Forward 1	6.7 kph	4.2 mph
Converter Drive – Forward 2	11.8 kph	7.3 mph
Converter Drive – Forward 3	20.8 kph	12.9 mph
Converter Drive – Forward 4	36 kph	22.3 mph
Converter Drive – Reverse 1	7.6 kph	4.7 mph
Converter Drive – Reverse 2	13.5 kph	8.4 mph
Converter Drive – Reverse 3	23.7 kph	14.7 mph
Direct Drive – Forward 1	Lock-up disabled	
Direct Drive – Forward 2	12.3 kph	7.7 mph
Direct Drive – Forward 3	21.9 kph	13.6 mph
Direct Drive – Forward 4	38.6 kph	24 mph
Direct Drive – Reverse 1	7.9 kph	4.9 mph
Direct Drive – Reverse 2	14.1 kph	8.8 mph
Direct Drive – Reverse 3	25.1 kph	15.6 mph

- Travel speeds based on two percent rolling resistance and 35/65-33 tires.

## Hydraulic Cycle Time

Raise	9.4 Seconds
Dump	2.4 Seconds
Lower Float Down (Empty)	3.8 Seconds
Total Hydraulic Cycle Time	15.6 Seconds

## Service Refill Capacities

Fuel Tank	712 L	188 gal
Cooling System	103 L	27.2 gal
Crankcase	60 L	15.9 gal
Transmission	70 L	18.5 gal
Differentials and Final Drives – Front	186 L	49 gal
Differentials and Final Drives – Rear	186 L	49 gal
Hydraulic System (factory fill)	470 L	124.2 gal
Hydraulic System (tank only)	267 L	70.5 gal

## Buckets

Bucket Capacities	6.3 m <sup>3</sup> –7.0 m <sup>3</sup>	8.2 yd <sup>3</sup> –9.2 yd <sup>3</sup>
Max. Bucket Capacity	7 m <sup>3</sup>	9.2 yd <sup>3</sup>



## Axles

Maximum Single-Wheel Rise and Fall	568 mm	22.4 in
Front	Fixed	
Rear	Oscillating $\pm 13^\circ$	

## Brakes

Brakes	Meet SAE ISO 3450:1996
--------	------------------------

## Cab

Cab – ROPS/FOPS	Meets SAE and ISO standards
Sound Performance	Meets ANSI, SAE and ISO standards

- Cat cab with integrated Rollover Protective Structure (ROPS) and Falling Object Protective Structure (FOPS) is standard.
- ROPS meets SAE J1040 APR99 and ISO 3471:1994 criteria.
- FOPS meets SAE J231 JAN 81 and ISO 3449:1992 Level II criteria.
- The operator sound exposure  $Leq$  (equivalent sound pressure level) measured according to the work cycle procedures specified in ANSI/SAE J1166 OCT 98 is 77 dB(A), for the cab offered by Caterpillar, when properly installed, maintained and tested with the doors and windows closed.
- Hearing protection may be needed when operating with an open operator station and cab (when not properly maintained or doors/windows open) for extended periods or in noisy environment.
- The exterior sound pressure level for the standard machine measured at a distance of 15 m (49.2 ft) according to the test procedures specified in SAE J88 JUN 86 mid-gear-moving operation is 81 dB(A).
- The sound power level is 115 dB(A) measured according to the dynamic test procedure and conditions specified in ISO 6395:1998/AMD. 1:1996 for a standard machine configuration.
- For “CE” marked configurations, the labeled sound power level is 110 dB(A) measured according to the test procedures and conditions specified in 2000/14/EC.

## Steering

Steering	Meets SAE and ISO standards
Total Steering Angle	$86^\circ$

- Full hydraulic, load-sensing steering system meets SAE J1511 FEB94 and ISO 5010:1992 specified standards.
- Center point frame articulation.
- Front and rear wheels track.

## Loader Hydraulic System

Main Hydraulic System Output at 2,010 rpm and 6900 kPa (1,000 psi)	492 L/min	130 gal/min
Relief Valve Setting	31 000 kPa	4,500 psi
Cylinders, Double Acting: Lift, Bore and Stroke	220 × 911 mm	8.7 × 35.9 in
Cylinder, Double Acting: Tilt, Bore and Stroke	220 × 1770 mm	8.7 × 69.7 in
Pilot System, Gear-Type Pump Output at 2,010 rpm and 2500 kPa (363 psi)	76 L/min	20.1 gal/min
Relief Valve Setting (low idle)	2400 kPa	348.1 psi

- With SAE 10W oil at  $66^\circ\text{C}$  ( $150^\circ\text{F}$ ).

# Dimensions

All dimensions are approximate.

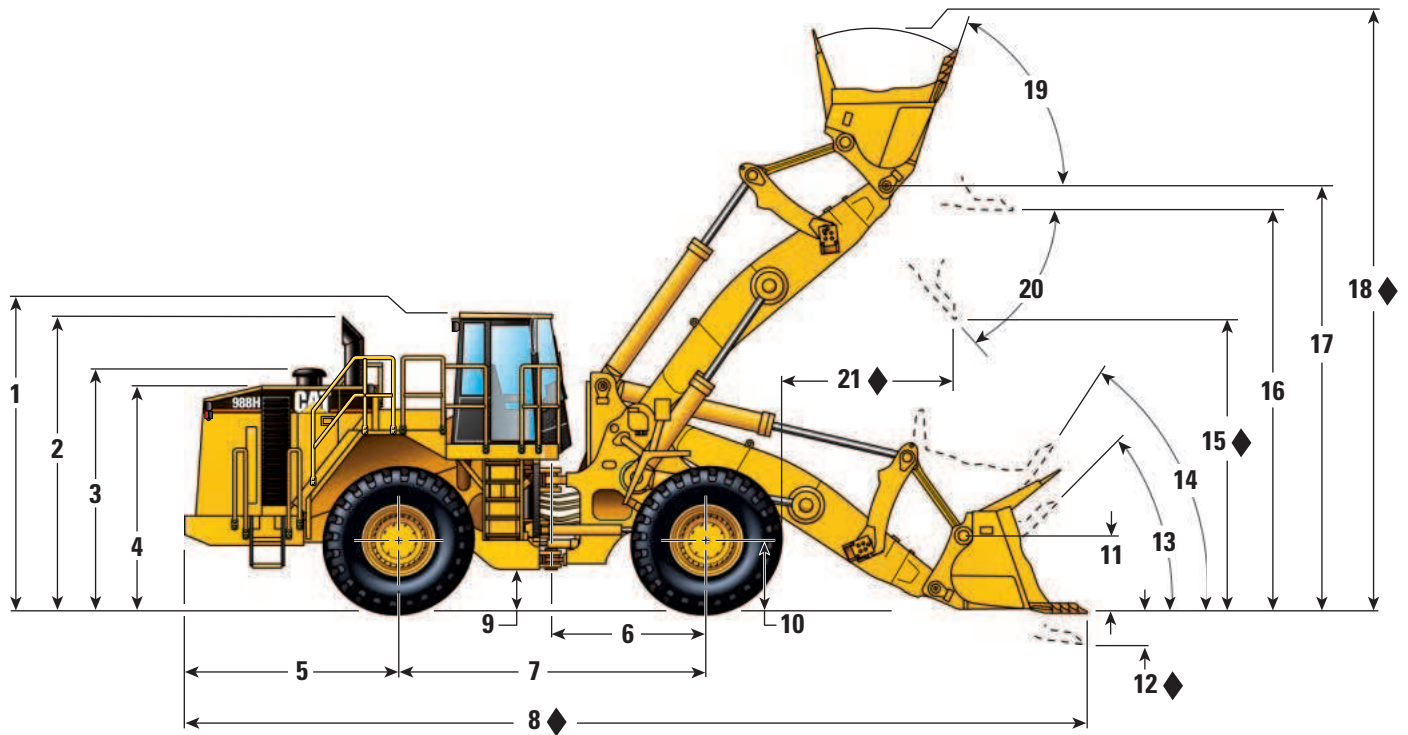

4.25 Meter Linkage

◆ Dimensions vary with bucket. Refer to Operation/Bucket Specifications.

1	Height to Top of Cab	4128 mm	13.54 ft		
2	Height to Top of Exhaust Stacks	4112 mm	13.49 ft		
3	Height to Top of Air Cleaner	3382 mm	11.1 ft		
4	Height to Top of Hood	3156 mm	10.35 ft		
5	Center Line of Rear Axle to Edge of Rear Bumper	3132 mm	10.28 ft		
6	Center Line of Front Axle to Hitch	2275 mm	7.46 ft		
7	Wheel Base Length	4550 mm	14.93 ft		
8	Length with Bucket on Ground	◆	◆		
9	Ground Clearance	549 mm	1.8 ft		
10	Height to Center of Wheel	978 mm	3.21 ft		
11	C-Pin Height	1009 mm	3.31 ft		
		899 mm*	2.95 ft*		
12	Dig Depth	226 mm	0.74 ft		
		195 mm*	0.64 ft*		
13	Rack Back Angle at Ground	47.8°			
		45.7°*			
14	Rack Back Angle at Carry	56.5°			
		54°*			
15	Clearance at Maximum Lift/Dump	3879 mm	12.73 ft		
		3466 mm*	11.37 ft*		
16	Height to Spillguard	5432 mm	17.82 ft		
		5019 mm*	16.47 ft*		
17	B-Pin Height	5853 mm	19.2 ft		
		5440 mm*	17.85 ft*		
18	Overall Height with Bucket Raised	◆	◆		
		◆*	◆*		
19	Rack Back Angle at Maximum Lift	65°			
		73°*			
20	Dump Angle at Maximum Lift	45°			
		45°*			
21	Reach	◆	◆		

\*3.88 Meter Linkage

## Operation/Bucket Specifications

Bucket Type		3.88 Meter Linkage		
		Spade Rock (Standard Bucket)	Wide Spade Rock	Spade Rock
GET		Teeth & Segments	Teeth & Segments	BOCE
Rated Capacity	m <sup>3</sup> (yd <sup>3</sup> )	6.4 (8.33)	6.9 (9.0)	6.9 (9.0)
Struck Capacity	m <sup>3</sup> (yd <sup>3</sup> )	5.3 (6.9)	5.7 (7.5)	5.7 (7.5)
Heaped Capacity	m <sup>3</sup> (yd <sup>3</sup> )	6.4 (8.33)	6.9 (9.0)	6.9 (9.0)
Bucket Width	mm (ft/in)	3810 (12'6")	3980 (13'1")	3964 (13'0")
Overall Height	mm (ft/in)	7699 (25'3")	7772 (25'6")	7772 (25'6")
Dump Clearance at 45° dump				
Bare	mm (ft/in)	3742 (12'3")	3682 (12'1")	3638 (11'11")
Teeth	mm (ft/in)	3466 (11'4")	3410 (11'2")	—
Reach at 45° dump				
Bare	mm (ft/in)	1494 (4'11")	1554 (5'1")	1881 (6'2")
Teeth	mm (ft/in)	2028 (6'8")	2084 (6'10")	—
Overall Length				
Bare	mm (ft/in)	11 877 (39'0")	11 962 (39'3")	11 982 (39'4")
Teeth	mm (ft/in)	12 215 (40'1")	12 294 (40'4")	—
Turning Radius at SAE Carry				
Bare	mm (ft/in)	8543 (28'0")	8641 (28'4")	8644 (28'4")
Teeth	mm (ft/in)	8597 (28'2")	8689 (28'6")	—
Reach at 45° dump and 2.13 m (7'0") HGT				
Bare	mm (ft/in)	2389 (7'10")	2427 (8'0")	2840 (9'4")
Teeth	mm (ft/in)	2924 (9'7")	2957 (9'8")	—
Reach with level boom level bucket				
Bare	mm (ft/in)	3435 (11'3")	3520 (11'7")	3972 (13'0")
Teeth	mm (ft/in)	4198 (13'9")	4277 (14'0")	—
Digging Depth – Bucket Level	mm (in)	195 (7.7")	195 (7.7")	185 (7.3")
Full Dump at Maximum Lift	degrees	51.4	51.4	51.4
Tipping Load				
Straight	kg (lb)	34 825 (76,776)	34 355 (75,740)	34 635 (76,357)
Articulated 43°	kg (lb)	29 368 (64,745)	28 923 (63,764)	29 182 (64,335)
Breakout Force	kN (lb-f)	378.4 (85,068)	360.6 (81,066)	383.9 (86,304)
Operating Weight	kg (lb)	49 546 (109,230)	49 816 (109,825)	49 716 (109,605)
Weight Distribution at SAE Carry				
Front	kg (lb)	25 265 (55,700)	25 746 (56,760)	25 540 (56,306)
Rear	kg (lb)	24 281 (53,530)	24 070 (53,065)	24 176 (53,299)



<b>3.88 Meter Linkage</b>			
<b>Straight Rock</b>	<b>Heavy Duty Quarry</b>	<b>High Abrasion</b>	<b>General Purpose</b>
<b>Teeth &amp; Segments</b>	<b>Teeth &amp; Segments</b>	<b>Teeth &amp; Segments</b>	<b>BOCE</b>
6.3 (8.2)	6.4 (8.33)	6.4 (8.33)	7.0 (9.2)
5.2 (6.8)	5.3 (6.9)	5.3 (6.9)	5.88 (7.7)
6.3 (8.2)	6.4 (8.33)	6.4 (8.33)	7.0 (9.2)
3800 (12'6")	3862 (12'8")	3926 (12'11")	3695 (11'2")
7699 (25'3")	7698 (25'3")	7699 (25'3")	7698 (25'3")
4011 (13'2")	3728 (12'3")	3811 (12'6")	3790 (12'5")
3735 (12'3")	3376 (11'1")	3447 (11'4")	—
1526 (5'0")	1543 (5'1")	1577 (5'2")	1720 (5'8")
1765 (5'9")	2076 (6'10")	2047 (6'9")	—
11 497 (37'9")	11 917 (39'1")	11 779 (38'8")	11 765 (38'7")
11 839 (38'10")	12 333 (40'6")	12 242 (40'2")	—
8550 (28'0")	8605 (28'3")	8625 (28'4")	8573 (28'2")
8634 (28'4")	8678 (28'6")	8682 (28'6")	—
2518 (8'3")	2401 (7'11")	2464 (8'1")	2729 (8'11")
2757 (9'1")	2934 (9'8")	2935 (9'8")	—
3480 (11'5")	3535 (11'7")	3552 (11'8")	3751 (12'0")
3822 (12'6")	4295 (14'1")	4225 (13'10")	—
195 (7.7")	225 (8.9")	195 (7.7")	191 (7.5")
51.4	51.4	51.4	51.4
35 257 (77,728)	32 650 (71,981)	33 833 (74,589)	35 026 (77,219)
29 816 (65,733)	27 239 (60,052)	28 383 (62,574)	29 568 (65,186)
467.4 (105,076)	360.7 (81,089)	389.2 (87,496)	433.1 (97,365)
49 261 (108,602)	51 181 (112,835)	51 016 (112,471)	49 401 (108,910)
24 616 (54,269)	28 161 (62,084)	27 367 (60,334)	24 988 (55,089)
24 645 (54,333)	23 020 (50,750)	23 649 (52,137)	24 413 (53,821)

## Operation/Bucket Specifications

Bucket Type		4.25 Meter Linkage		
		Spade Rock (Standard Bucket)	Wide Spade Rock	Spade Rock
GET		Teeth & Segments	Teeth & Segments	BOCE
Rated Capacity	m <sup>3</sup> (yd <sup>3</sup> )	6.4 (8.33)	6.9 (9.0)	6.9 (9.0)
Struck Capacity	m <sup>3</sup> (yd <sup>3</sup> )	5.3 (6.9)	5.7 (7.5)	5.7 (7.5)
Heaped Capacity	m <sup>3</sup> (yd <sup>3</sup> )	6.4 (8.33)	6.9 (9.0)	6.9 (9.0)
Bucket Width	mm (ft/in)	3810 (12'6")	3980 (13'1")	3964 (13'0")
Overall Height	mm (ft/in)	8112 (26'7")	8186 (26'10")	8186 (26'10")
Dump Clearance at 45° dump				
Bare	mm (ft/in)	4155 (13'8")	4095 (13'5")	4051 (13'3")
Teeth	mm (ft/in)	3879 (12'9")	3823 (12'7")	—
Reach at 45° dump				
Bare	mm (ft/in)	1591 (5'3")	1652 (5'5")	1699 (5'7")
Teeth	mm (ft/in)	2126 (7'0")	2182 (7'2")	—
Overall Length				
Bare	mm (ft/in)	12 321 (40'5")	12 406 (40'8")	12 426 (40'9")
Teeth	mm (ft/in)	12 658 (41'6")	12 738 (41'9")	—
Turning Radius at SAE Carry				
Bare	mm (ft/in)	8731 (28'8")	8828 (29'0")	8803 (28'11")
Teeth	mm (ft/in)	8787 (28'10")	8879 (29'2")	—
Reach at 45° dump and 2.13 m (7'0") HGT				
Bare	mm (ft/in)	2785 (9'2")	2825 (9'3")	2951 (9'8")
Teeth	mm (ft/in)	3320 (10'11")	3355 (11'0")	—
Reach with level boom level bucket				
Bare	mm (ft/in)	3805 (12'6")	3890 (12'9")	3947 (12'11")
Teeth	mm (ft/in)	4568 (15'0")	4647 (15'3")	—
Digging Depth – Bucket Level	mm (in)	226 (8.9")	226 (8.9")	216 (8.5")
Full Dump at Maximum Lift	degrees	48.5	48.5	48.5
Tipping Load				
Straight	kg (lb)	32 445 (71,529)	32 014 (70,579)	32 264 (71,130)
Articulated 43°	kg (lb)	27 191 (59,946)	26 780 (59,040)	27 012 (59,551)
Breakout Force	kN (lb-f)	409.2 (91,992)	390.1 (87,698)	415.3 (93,363)
Operating Weight	kg (lb)	50 574 (111,497)	50 844 (112,092)	50 744 (111,871)
Weight Distribution at SAE Carry				
Front	kg (lb)	25 583 (56,401)	26 088 (57,514)	25 874 (57,042)
Rear	kg (lb)	24 991 (55,096)	24 756 (54,578)	24 870 (54,829)

<b>4.25 Meter Linkage</b>			
<b>Straight Rock</b>	<b>Heavy Duty Quarry</b>	<b>High Abrasion</b>	<b>General Purpose</b>
<b>Teeth &amp; Segments</b>	<b>Teeth &amp; Segments</b>	<b>Teeth &amp; Segments</b>	<b>BOCE</b>
6.3 (8.2)	6.4 (8.33)	6.4 (8.33)	7.0 (9.2)
5.2 (6.8)	5.3 (6.9)	5.3 (6.9)	5.88 (7.7)
6.3 (8.2)	6.4 (8.33)	6.4 (8.33)	7.0 (9.2)
3800 (12'6")	3862 (12'8")	3926 (12'11")	3695 (11'2")
8112 (26'7")	8112 (26'7")	8112 (26'7")	8111 (26'7")
4424 (14'6")	4141 (13'7")	4225 (13'10")	4203 (13'9")
4148 (13'7")	3790 (12'5")	3860 (12'8")	—
1623 (5'4")	1641 (5'5")	1674 (5'6")	1818 (6'0")
1863 (6'1")	2173 (7'2")	2145 (7'0")	—
11 941 (39'2")	12 358 (40'7")	12 223 (40'1")	12 209 (40'1")
12 283 (40'4")	12 774 (41'11")	12 686 (41'7")	—
8738 (28'8")	8795 (28'10")	8812 (28'11")	8763 (28'9")
8824 (28'11")	8871 (29'1")	8873 (29'1")	—
2904 (9'6")	2801 (9'2")	2861 (9'5")	3114 (10'3")
3144 (10'4")	3334 (10'11")	3332 (10'11")	—
3850 (12'8")	3905 (12'10")	3922 (12'10")	4121 (13'6")
4192 (13'9")	4665 (15'4")	4595 (15'1")	—
226 (8.9")	256 (10.1")	226 (8.9")	222 (8.7")
48.5	48.5	48.5	48.5
32 867 (72,459)	30 346 (66,901)	31 421 (69,271)	32 650 (71,981)
27 628 (60,909)	25 130 (55,402)	26 172 (57,699)	27 394 (60,393)
505.1 (113,551)	390.5 (87,788)	421.6 (94,779)	468.3 (105,278)
50 289 (110,868)	52 209 (115,101)	52 044 (114,737)	50 429 (111,177)
24 907 (54,910)	28 634 (63,127)	27 811 (61,313)	25 293 (55,761)
25 382 (55,958)	23 575 (51,974)	24 233 (53,425)	25 136 (55,415)



## Tire Dimensions/Specifications

	Width over tires		Ground clearance		Change in vertical dimensions		Change in operating weight		Change in full turn static tipping load	
	mm	inches	mm	inches	mm	inches	kg	lb	kg	lb
35/65R33 (L-4) Michelin XLDD1	3579	140.9	445	17.5	—	—	—	—	—	—
35/65-33 42 PR (L-5) Bridgestone D-Lug	3541	139.4	544	21.4	-99	-3.9	2259	4980	1310	2888
35/65R33 (L-4) Bridgestone V-Steel N Traction VSNT	3566	140.4	483	19.0	-38	-1.5	664	1464	385	849
35/65R33 (L-5) Bridgestone V-Steel D-Lug VSDL	3566	140.4	498	19.6	-53	-2.1	1257	2772	729	1608
35/65-33 42PR (L-5) General LD 250 Belted	3487	137.3	506	19.9	-61	-2.4	1510	3328	876	1930
875/65R33 (L-4) Goodyear RL-4K Hi Stability	3487	137.3	506	19.9	-61	-2.4	552	1217	320	705
35/65R33 (L-5) Goodyear RL-5K 20 20 6S	3574	140.7	508	20.0	-64	-2.5	974	2148	565	1246
35/65-33 42PR (L-5) Goodyear NRL D/L 5A	3574	140.7	508	20.0	-64	-2.5	1646	3628	954	2104
875/65R33 (L-5) Goodyear RL-5K Hi Stability	3574	140.7	508	20.0	-64	-2.5	1486	3276	862	1900
35/65R33 (L-5) Michelin XLDD2	3579	140.9	463	18.2	-18	-0.7	648	1428	376	828
35/65R33 (L-5) Michelin XMINED2	3579	140.9	478	18.8	-33	-1.3	1404	3096	815	1796

**NOTE:** In certain applications (such as load-and-carry work), the loader's productive capabilities might exceed the tires tonnes-km/f (ton-mph) capabilities. Caterpillar recommends that you consult a tire supplier to evaluate all conditions before selecting a tire model. Other special tires are available on request.

## Standard Equipment

*Standard equipment may vary. Consult your Caterpillar dealer for details.*

### Electrical

- Alarm, back-up
- Alternator (100-amp)
- Batteries, maintenance-free (four 1,000 CCA)
- Deutsch terminal connectors
- Diagnostic connector
  - Starting and charging system
- Electrical converter, 12-volt
- Electrical system, 24-volt
- Lighting system, Halogen
  - (Front and Rear)
- Starter, electric (heavy-duty)
- Starter receptacle for emergency start

### Operator Environment

- Air Conditioner
- Cab, sound-suppressed, pressurized
  - Internal four-post rollover protective structure (ROPS/FOPS)
  - Radio ready for (entertainment) includes antenna, speakers and converter (12-volt 15-amp)
- 12V cigar lighter, 12V power port and ashtray
- Coat hook
- Electro-hydraulic tilt and lift controls
- Heater and defroster
- Horn, electric
- Lights, (interior cab)
- Lunchbox and beverage holders
- Loose Material Mode
- Monitoring system (Caterpillar Monitoring System [EMS-III])
  - Action alert system, three category
- Instrumentation, Gauges:
  - Engine coolant temperature
  - Fuel level
  - Hydraulic oil temperature
  - Transmission temperature
  - Speedometer/tachometer
- Instrumentation, Warning Indicators:
  - Axle oil temperature (front/rear)
  - Brake oil pressure
  - Engine intake/combustion air temperature
  - Electrical system, low voltage
  - Engine oil pressure
  - Engine overspeed
  - Fuel pressure
  - Hydraulic oil filter status
  - Parking brake status
  - Transmission filter status
- Mirrors, rearview (exterior mounted)
- Seat (cloth), Cat Comfort, air suspension
- Seat belt, retractable, 76 mm (3 in) wide
- STIC control system with steering lock

- Tilt and lift control system lock
- Tinted glass
- Transmission gear (indicator)
- Wet-arm wiper/washers (front and rear)
  - Intermittent front wiper

### Power Train

- Brakes, full hydraulic, enclosed, wet multiple disc service brakes
- Case drain filtration
- Demand fan
- Electric fuel priming aid
- Engine, Cat C18 MEUI Direct Injected Diesel with ACERT<sup>®</sup> Technology and ADEM<sup>™</sup> IV controller
- Guard, three piece transmission
- Parking brake
- Precleaner, engine air intake
- Radiator, Next Generation Modular Radiator (NGMR)
- Remote Electronic Clutch Pressure Control (ECPC)
  - pressure taps
- Separated cooling system
- Starting aid (ether)/automatic
- Throttle lock
- Torque converter, impeller clutch with rimpull control system
- Transmission, planetary, auto shift with 4F/3R speed range control

### Other Standard Equipment

- Automatic bucket tilt/lift kickouts, electronically adjustable from cab
- Cab tilt support
- Counterweight
- Doors, service access (locking)
- Engine, crankcase, 500 hour interval with CH4 oil
- Ground level fuel fill
- Hitch, drawbar with pin
- Hydraulic oil cooler
- Lower cab cover
- Muffler (under hood)
- Oil sampling valves
- Stairway, left side rear access
- Vandalism protection caplocks
- Venturi stack

### Tires, Rims and Wheels

- An allowance for tires is included in the base machine price.
- Tire selections are shown in the Tire/Supplemental Specifications list.

### Antifreeze

- Premixed 50 percent concentration of extended life coolant with freeze protection to -34° C (-29° F)

## Optional Equipment

*Optional equipment may vary. Consult your Caterpillar dealer for details.*

Auto Lube	Lights, HID
Auxiliary lights	Linkage, 4.25 meter
Axle oil-coolers	Lock-up clutch
Block handler configuration (Custom)	Mid-ambient cooling
Buckets	No-SPIN differential, rear only
Bulk loader configuration (Custom)	Oil change, high-speed
Computer Aided Earthmoving System (CAES) ready	Payload Control System (PCS)
Directional lights	Product Link
Engine Brake	QuickLube
Extended Life Coolant -50° C (-58° F)	Rear intermittent wiper
Forestry configuration (Custom)	Rear chain clearance
Fuel, fast fill	Ride control
Fuel, heater	Right-hand stairway
Fuel, fast fill and heater	Roading fenders, front and rear
Guards	Roof, extended
Crankcase	Secondary steering
Steering cylinders	Sound suppression, exterior
Heater, engine coolant, 120-volt	Steel mill configuration (Custom)
Heater, engine coolant, 220-volt	Tires
High ambient cooling	
Hydraulic, three valve	



---

## Notes

# 988H Wheel Loader

For more complete information on Cat products, dealer services,  
and industry solutions, visit us on the web at [www.cat.com](http://www.cat.com)

© 2006 Caterpillar  
All Rights Reserved  
Printed in U.S.A.

Materials and specifications are subject to change without notice.  
Featured machines in photos may include additional equipment.  
See your Caterpillar dealer for available options.

AEHQ5618-01 (3-06)  
Replaces AEHQ5618

CAT, CATERPILLAR, their respective logos and "Caterpillar Yellow,"  
as well as corporate and product identity used herein, are  
trademarks of Caterpillar and may not be used without permission.

**CATERPILLAR**<sup>®</sup>