

# D10T

Track-Type Tractor

**CATERPILLAR**<sup>®</sup>



#### **Engine**

Engine Model	Cat <sup>®</sup> C27 ACERT <sup>™</sup>	
Flywheel Power	433 kW	580 hp
Gross Power	482 kW	646 hp

#### **Weights**

Operating Weight	66 451 kg	146,499 lb
Shipping Weight	48 263 kg	106,402 lb

*Courtesy of Machine.Market*

## D10T Features

### C27 Engine with ACERT Technology

*Tier 3 certified, optimizes engine performance and provides low exhaust emissions.*

### Drive Train

*Electronically controlled powershift transmission, efficient clutch/brake steering and durable planetary final drives deliver outstanding power transfer and longer life.*

### Operator Station

*Designed for operator comfort, convenience, and productivity. Machine controls and displays are all at the operator's fingertips to maximize operator productivity.*

### Serviceability and Customer Support

*Combine easy access, modular components with the Cat Dealer repair and rebuild capability ensures rapid machine repair and minimum downtime.*

## Contents

C27 Engine with ACERT™ Technology .....	3
Operator Station.....	4
Implement and Steering Controls .....	5
Drive Train .....	6
Undercarriage .....	7
Structure.....	8
Work Tools.....	9
Serviceability.....	10
Customer Support.....	11
D10T Track-Type Tractor Specifications .....	12
D10T Standard Equipment.....	15
D10T Optional Equipment.....	16
Notes.....	17



**Strength from the past. Power for the future.™ The D10T combines power and efficiency with advanced technology for outstanding production at a lower cost-per-yard.**

**Engineered for demanding work.**

**The durable construction of the D10T is well suited for tough working conditions. Combined with the C27 engine for superior performance, fuel economy and meeting emission targets with the help of ACERT Technology, it keeps material moving with the reliability and low operating costs you expect from Cat tractors.**



# C27 Engine with ACERT™ Technology

Optimizes engine performance and meets emission regulations.

## C27

Performing at full-rated net power of 433 kW (580 hp) at 1800 rpm with a torque rise of 21 percent, the D10T can doze through the toughest material. Matched to the high efficiency torque divider and electronically controlled power shift transmission, it will provide years of reliability.

## ADEM™ A4 Engine Controller

The ADEM A4 electronic control module manages fuel delivery and airflow to get the best performance per liter (gallon) of fuel used. It provides flexible fuel mapping, allowing the engine to respond quickly to varying application needs.

## MEUI Fuel System

Through the use of multiple injection fuel delivery, combustion chamber temperatures are lower, generating fewer emissions and optimized fuel efficiency. This is accomplished with the MEUI fuel system, which strikes the proper balance between the precision of the electronic control system and the simplicity of mechanically controlled unit fuel injectors. The result is more productivity and lower fuel consumption.

## Air-to-Air Aftercooling

Air-to-air aftercooling provides cooled compressed air to the engine intake manifold, thus reducing emissions and maximizing fuel efficiency.

## Overhead Cams

Two, single overhead cams are driven by gears on the flywheel end of the engine. Placing them on the flywheel end significantly reduces noise and vibration. To reduce wear, two pendulum absorbers are mounted at the front of the camshafts. Together, these features contribute to the long-life and durability of this engine.

## Service

Easier maintenance and repair through monitoring key functions and logging critical indicators. Electronic diagnostic access is possible with the Cat Electronic Technician.

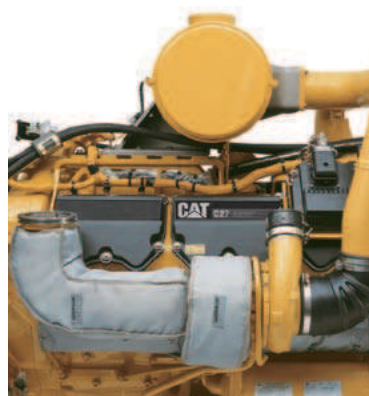



# Operator Station

Designed for operator comfort, convenience, and productivity.

## **Operator Controls**

Power train and implement controls are conveniently placed for low operator fatigue and ease of control.

## **Cat Monitoring Display System**

The combination dash mounted instrument cluster and the Advisor Monitoring System provide key machine operating information and give the operator and service technician insight into the machine's operation and maintenance needs.

## **Wide Panoramic View**

A large view hole in the single-shank ripper frame provides a view of the ripper tip. The tapered hood, notched fuel tank, and narrow ripper carriage gives the operator a clear line of sight to the front and rear work areas. The single-pane door windows provide an excellent view to the sides and blade.

## **Fuse Panel and Diagnostic Access**

The new compartment features a single location fuse panel that includes a diagnostic port for the Cat ET to connect for rapid machine diagnostics.

## **Comfortable Operation**

Standard isolation-mounted cab reduces noise and vibration. The Cat Comfort Series Seat is fully adjustable and designed for comfort and support. Conveniently located air circulation vents evenly distribute airflow within the cab. Optional air conditioning available.



# Implement and Steering Controls

Reduced operator fatigue for increased performance.

## Dozer Control Lever

A low-effort, electronic dozer control handle gives the operator control of all dozer functions with one hand. Fore/aft movement of the lever lowers and raises the blade. Left/right movement directionally tilts the blade. The thumb lever at the top of the handle controls blade pitch fore and aft. The trigger switch toggles between single and dual tilt. Blade response and blade float can be set/adjusted using the Advisor Panel.

The left and right side thumb buttons provide control over the semi-automated blade pitch functions (load, carry, and spread) that the dual tilt attachment provides.

The two buttons also provide control over the AccuGrade™ blade control attachment when the machine is so equipped. The buttons turn on AccuGrade, provide manual increment and decrement control, and turn off AccuGrade.

## Electronic Ripper Control

A rigidly mounted handgrip provides firm support for the operator even when ripping in the roughest terrain. The low effort thumb lever controls raising and lowering. The finger lever controls shank-in and shank-out positioning. Programmable features, such as Auto Lift, Shank-out, and Auto Stow, increase efficiency for the operator.

## Finger Tip Controls (FTC)

Clustered for easy, one-hand operation to the operator's left. They control steering, machine direction and gear selection.

## AutoCarry (optional)

AutoCarry provides automatic blade control during the carry segment of dozing cycle. It is intended to enhance the operator's productivity in high production earthmoving with carry distances over 30.5 m (100 ft).

## Computer Aided Earthmoving System (CAES) (optional)

This on-board electronic site plan directs machine operators, in real-time, where to cut and fill. A graphical map of the design plan and a view of the machine's horizontal and vertical position simplify operation and enhance production.

This advanced information tool combines GPS technology (centimeter-level) and in-cab computing capabilities for precise grade and slope control. Ideal applications include benches, roads, leach pads, dump areas, and reclamation sites.

## AccuGrade (optional)

Automated blade control system that allows operators to grade with increased accuracy. Machine-mounted sensors are used to calculate precise blade slope and elevation.



# Drive Train

Provides maximum efficiency in combination with the C27 engine.



## Torque Divider

A single-stage torque converter with output torque divider sends 75 percent of engine torque through the converter and 25 percent through a direct drive shaft for greater driveline efficiency and higher torque multiplication. The torque converter shields the driveline from sudden torque shocks and vibration.

## Planetary Power Shift Transmission

Three speeds forward and three speeds reverse, utilizing large diameter, high-capacity, oil-cooled clutches.

- Modulation system permits fast speed and direction changes.
- Modular transmission and bevel gear slide into rear case for servicing ease, even with ripper installed.
- Oil-to-water cooler for maximum cooling capacity.
- Forced oil flow lubricates and cools clutch packs to provide maximum clutch life.

## Electronic Clutch Pressure Control

Provides smoother shifting by modulating individual clutches.

## Steering Clutch and Brake

Fade resistant and adjustment free. The multi-disc, oil-cooled steering clutches are hydraulically applied and electronically controlled. The brakes are applied by springs and hydraulically released for safe and reliable braking performance.

## Drawbar Pull vs. Ground Speed

As loads on the tractor increase, the D10T offers unmatched lugging capability and smooth shifting as the need occurs to change gears under varying loads. The 3-speed forward, 3-speed reverse transmission offers excellent runout speeds.

## Elevated Final Drives

Isolated from ground and equipment induced impact loads for extended power train life. Crown-shaved drive gears provide smooth, quiet, low maintenance operation. Splash lubrication and Duo-Cone™ Seals extend service life.

## Modular Power Train

The modular power train design permits quick removal and installation of major components such as the engine, transmission and final drives.

## Power Shift with Steering Clutch and Brake

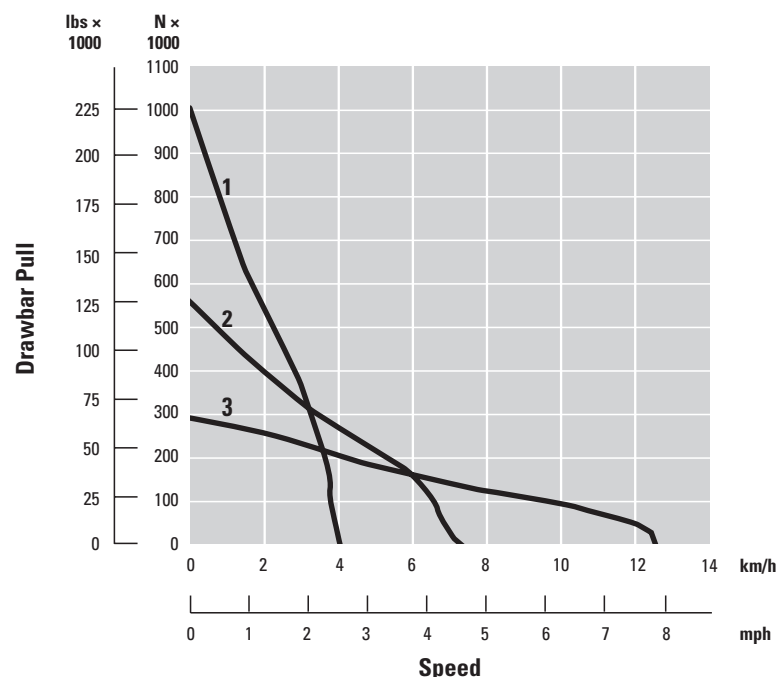

- 1 – 1st Gear Forward
- 2 – 2nd Gear Forward
- 3 – 3rd Gear Forward



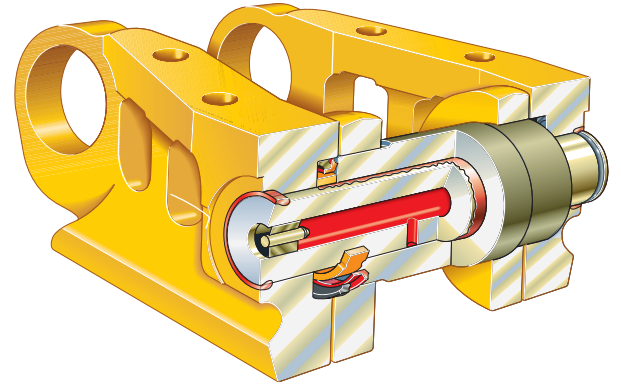
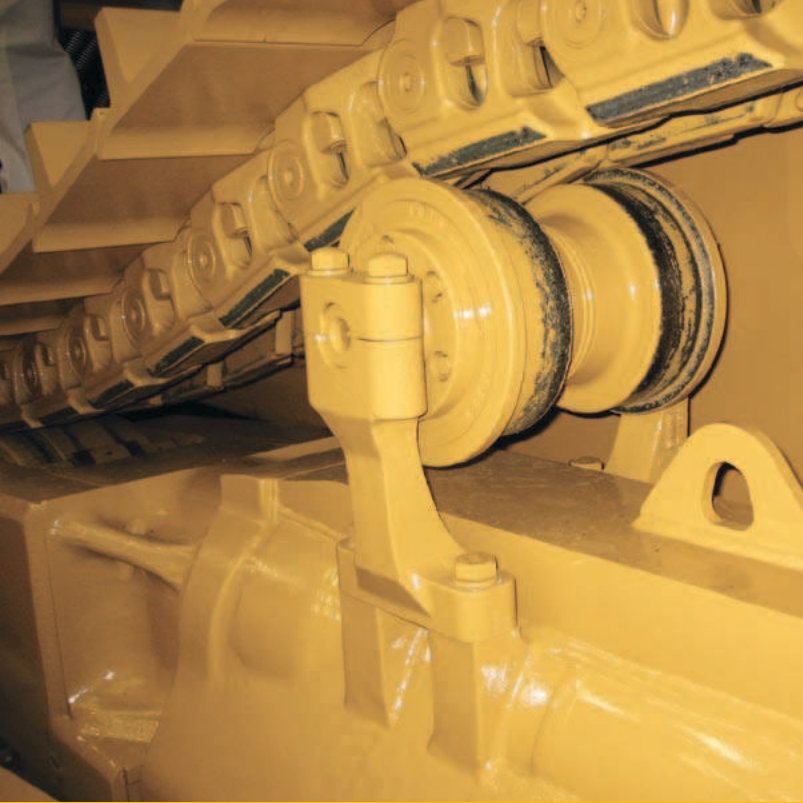

# Undercarriage

Designed for optimized machine balance and the best performance.

## **Suspended Undercarriage Design**

Absorbs impact loads, to reduce the shock loads transferred to the undercarriage, by up to 50%.

## **Bogie Suspension**

Bogie suspension conforms closely to the ground providing up to 15 percent more ground contact, especially in uneven terrain. Higher traction means less slippage, better balance, and a smoother ride.

## **Integrated Carrier Roller Mount**

The carrier roller mount is cast into the track roller frame making it easier to add the optional carrier roller in the field, if conditions require it.

## **Rollers and Idlers**

Feature symmetric Duo-Cone seals for long sealing life to prevent oil loss and dirt entry. Toric rings maintain performance over a wide range of temperatures.

## **Roller Frames**

Roller frames are tubular to resist bending and twisting, with added reinforcement.

## **Positive Pin Retention (PPR) Sealed and Lubricated Track**

Designed for high-impact and high load applications, the Caterpillar design locks the link to the pin.

## **Sprocket Segments**

Made exclusively of Cat Tough Steel™ for longer wear life and precision machined for fit.

## **Track Shoes**

Track shoes are available in a variety of sizes and styles to match the working conditions.

# Structure

Engineered for maximum production and service life.



## Mainframe Strength

The D10T mainframe is built to absorb high impact shock loads and twisting forces.

## Frame Rails

Full box section, designed to keep components rigidly aligned.

## Heavy Steel Castings

Add strength to the main case, equalizer bar saddle, front cross member and tag-link trunnion.

## Top and Bottom Rails

Continuous rolled sections, with no machining or welding, to provide superior mainframe durability.

## Main Case

Elevates the final drives well above the ground level work area to protect them from impact loads, abrasion and contaminants.

## Pivot Shaft

The D10T pivot shaft runs through the mainframe and connects to the roller frames, allowing independent oscillation. The full-length pivot shaft distributes impact loads throughout the case, reducing the bending stress on the case.

## Equalizer Bar

The equalizer bar features limited slip seals and an oil-lubricated joint for better oil flow. Remote lube passages simplify maintenance. Large forged pads reduce wear on the mainframe and extend sealed joint life.

## Engine and Radiator Guard Mount

The new fabricated common front engine and rear radiator mount feature heavy castings.

## Tag-Link

The Tag-Link brings the blade closer to the machine for more precise dozing and load control.

The Tag-Link design provides solid lateral stability and better cylinder positions for constant break out force, independent of blade height.





# Work Tools

Provide the flexibility to match the machine to the job.

## **Bulldozers**

All blades feature a strong box-section design that resists twisting and cracking. Blades are made of Cat DH-2™ steel that has high tensile strength and stands up to the most severe applications. Heavy moldboard construction and hardened bolt-on cutting edges and end bits add strength and durability.

- Semi-Universal Blade – Built for tough applications where penetration is important.
- High-Capacity Universal Blade – Maximizes capacity for moving big loads over long distances.
- Optional Dual Tilt – Allows the operator to optimize the blade pitch angle.
- Cutting Edges and End Bits – Cutting edges are made of DH-2 steel. End bits are made of DH-3 steel for maximum service life.
- Cat Work Tools offer a range of special application blades.

## **Rippers**

- Multi-Shank Ripper – Tailors the tractor to the material by using one, two or three shanks.
- Single-Shank Ripper – Operator can adjust the shank depth from the seat using an optional single-shank pin puller. Large one-piece shank is available in deep ripping configuration.

## **Rear Counterweights**

Provide proper tractor balance to maximize dozing production. Recommended if not equipped with any other rear attachment.

## **Winches**

Several options are available. Contact your Cat Dealer.





# Serviceability

The most serviceable machines from the most committed dealers.

## **Serviceability**

Minimizes maintenance and repair downtime. New sight gauges, filter locations, improved access to oil and coolant sampling ports, and an engine compartment mounted work lamp, make daily and periodic service faster and easier. Equipped with a dozer and ripper, there are only 18 lube points.

## **Engine Oil Filters**

Engine oil filters are located on the engine for easy servicing access and minimal downtime. Further time is saved with fast fuel and quick oil change attachments.

## **Quick Disconnect Fittings**

Allow for fast diagnosis of the power train, hydraulics and attachment oil systems.

## **S-O-S<sup>SM</sup> Analysis**

Scheduled Oil Sampling made easier through live sampling ports for the engine oil, hydraulics and coolant.

## **Cat Product Link**

Product Link allows the customer or dealer to obtain machine diagnostics and location information from their offices. It provides updates on service meter hours, machine condition and machine location, as well as integrated mapping/route planning. Built-in flexibility allows for future technology development.



# Customer Support

The Cat Dealer network keeps your fleet up and running.

## Machine Selection

Make detailed comparisons of the machines you are considering before you buy. How long do components last? What is the cost of preventive maintenance? What is the true cost of lost production? Your Cat Dealer can give you answers to these very important questions.

## Purchase

Consider the financing options available as well as day-to-day operating costs. This is also the time to look at dealer services that can be included in the cost of the machine to yield lower equipment owning and operating costs over the long run.

## Product Support

Plan for effective maintenance before buying equipment. Choose from your dealer's wide range of maintenance services at the time you purchase your machine. Programs such as Custom Track Service (CTS), S•O•S analysis, Technical Analysis and guaranteed maintenance contracts give peak life and performance to your machine.

## Parts Program

You will find nearly all parts at your dealer parts counter. Cat Dealers use a world-wide computer network to find in-stock parts to minimize machine downtime.

Ask about your Cat Dealer's exchange program for major components. This can shorten repair time and lower costs.

## Remanufactured Components

Genuine Cat Remanufactured parts save you money. You receive the same warranty and reliability as new products at cost savings of 40 to 70 percent. Components are available for the drive train, engine, and hydraulics.

## Operation

Improving operating techniques can boost your profits. Your Cat Dealer has training videotapes, literature, and other ideas to help you increase productivity.



# D10T Track-Type Tractor Specifications

## Engine

Engine Model	Cat® C27 ACERT™	
Gross Power		
SAE J1995	482 kW	646 hp
ISO 14396	471 kW	632 hp
Net Power		
SAE J1349/ ISO 9249 Min Fan	450 kW	603 hp
SAE J1349/ ISO 9249	433 kW	580 hp
80/1269/EEC	433 kW	580 hp
Bore	137.2 mm	5.4 in
Stroke	152.4 mm	6 in
Displacement	27 L	1,647.6 in <sup>3</sup>

- Engine ratings apply at 1,800 rpm.
- Net power advertised is the power available at the flywheel when the engine is equipped with fan at max speed (unless otherwise noted), air cleaner, muffler and alternator.
- No derating required up to 4572 m (15,000 ft) altitude.

## Service Refill Capacities

Fuel Tank	1204 L	318 gal
Cooling System	151 L	39.9 gal
Engine Crankcase*	76 L	20.1 gal
Power Train	193 L	51 gal
Final Drives (each)	23 L	6.1 gal
Roller Frames (each)	64 L	16.9 gal
Pivot Shaft Compartment	33 L	8.7 gal

\*With oil filters.

## Weights

Operating Weight	66 451 kg	146,499 lb
Shipping Weight	48 263 kg	106,402 lb

- Operating Weight: Includes hydraulic controls, blade tilt cylinder, coolant, lubricants, 100% fuel, ROPS, FOPS cab, SU-Blade, Single-Shank Ripper, 610 mm (24 in) ES shoes, and operator.
- Shipping Weight: Includes coolant, lubricants, 20% fuel, ROPS, FOPS cab, and 610 mm (24 in) ES shoes.

## Undercarriage

Shoe Type	Extreme Service	
Width of Shoe	610 mm	24 in
Shoes/Side	44	
Grouser Height	93 mm	3.7 in
Pitch	260 mm	10.2 in
Ground Clearance	615 mm	24.2 in
Track Gauge	2550 mm	100.4 in
Length of Track on Ground	3885 mm	12 ft 9 in
Ground Contact Area	4.7 m <sup>2</sup>	7,326 in <sup>2</sup>
Track Rollers/Side	8	
Number of Carrier Rollers	1 per side (optional)	

- Positive Pin Retention Track.

## Track Roller Frame

Oscillation	351 mm	13.8 in
-------------	--------	---------

## Hydraulic Controls

Pump Type	Gear	
Lift Cylinder Flow	404 L/min	107 gal/min
Tilt Cylinder Flow	112 L/min	30 gal/min
Bulldozer Relief Valve Setting	18 790 kPa	2,725 psi
Tilt Cylinder Relief Valve Setting	20 340 kPa	2,950 psi
Ripper (Lift) Relief Valve Setting	18 790 kPa	2,725 psi
Ripper (Pitch) Relief Valve Setting	18 790 kPa	2,725 psi
Tank Capacity	144 L	38 gal

- Pump output measured at 1,800 rpm and 6895 kPa (1,000 psi).
- Electro-hydraulic pilot valve assists operations of ripper and dozer controls. Hydraulic system includes four valves for use with blade and ripper.
- Complete system consists of pump, tank with filter, oil cooler, valves, lines, linkage and control levers.

## Steering and Brakes

Hydraulically applied multiple- disk clutches diameter	392 mm	15.4 in
---	--------	---------

## Transmission

1 Forward	4 km/h	2.5 mph
2 Forward	7.2 km/h	4.5 mph
3 Forward	12.7 km/h	7.9 mph
1 Reverse	5.2 km/h	3.2 mph
2 Reverse	9 km/h	5.6 mph
3 Reverse	15.8 km/h	9.8 mph
1 Forward – Max Drawbar Pull (1000)	1000.9 N	225 lbf
2 Forward – Max Drawbar Pull (1000)	556 N	125 lbf
3 Forward – Max Drawbar Pull (1000)	306.9 N	69 lbf



## Blades

Type	10SU	
Capacity (SAE J1265)	18.5 m <sup>3</sup>	24.2 yd <sup>3</sup>
Width (over end bits)	4860 mm	15 ft 11 in
Height	2120 mm	6 ft 11 in
Digging Depth	674 mm	26.5 in
Ground Clearance	1497 mm	58.9 in
Maximum Tilt	993 mm	39.1 in
Weight* (without hydraulic controls)	10 229 kg	22,551 lb
Total Operating Weight** (with Blade and Single-Shank Ripper)	66 451 kg	146,499 lb

Type	10U	
Capacity (SAE J1265)	22 m <sup>3</sup>	28.8 yd <sup>3</sup>
Width (over end bits)	5260 mm	17 ft 3 in
Height	2120 mm	6 ft 11 in
Digging Depth	674 mm	26.5 in
Ground Clearance	1497 mm	58.9 in
Maximum Tilt	1074 mm	42.3 in
Weight* (without hydraulic controls)	10 784 kg	23,775 lb
Total Operating Weight** (with Blade and Single-Shank Ripper)	67 006 kg	147,723 lb

\*Includes blade tilt cylinder.

Add 840 kg (1,852 lb) for 10SU ABR blade.

Add 1629 kg (3,591 lb) for 10U ABR blade.

\*\*Total Operating Weight: Includes hydraulic controls, blade tilt cylinder, coolant, lubricants, 100% fuel, ROPS, FOPS cab, Blade, Single-Shank Ripper, 610 mm (24 in) ES shoes, and operator.

## Rippers

Type	Single-Shank, Adjustable Parallelogram	
Added Length	1760 mm	5 ft 9 in
Number of Pockets	1	
Maximum Clearance Raised (under tip, pinned in bottom hole)	1058 mm	41.7 in
Maximum Penetration (standard tip)	1494 mm	58.8 in
Maximum Penetration Force (shank vertical)	205 kN	46,086 lb
Pry out Force	415.3 kN	93,363 lb
Weight (without hydraulic controls)	7117 kg	15,690 lb
Total Operating Weight* (with SU-Blade and Ripper)	66 451 kg	146,499 lb

Type	Multi-Shank, Adjustable Parallelogram	
Number of Pockets	3	
Added Length	1760 mm	5 ft 10 in
Overall Beam Width	2920 mm	115 in
Maximum Clearance Raised (under tip, pinned in bottom hole)	1045 mm	41.1 in
Maximum Penetration (standard tip)	876 mm	34.5 in
Maximum Penetration Force (shank vertical)	205 kN	46,086 lb
Pry out Force (Multi-Shank Ripper with one tooth)	415.3 kN	93,363 lb
Weight (one shank, without hydraulic controls)	7968 kg	17,566 lb
Additional Shank	526.2 kg	1,160 lb
Total Operating Weight* (with SU-Blade and Ripper)	67 302 kg	148,375 lb

\*Total Operating Weight: Includes hydraulic controls, blade tilt cylinder, coolant, lubricants, 100% fuel, ROPS, FOPS cab, SU-Blade, Ripper, 610 mm (24 in) ES shoes, and operator.

## Winches

Winch Model	Consult your Cat Dealer for installation arrangements.
-------------	--

## Standards

- ROPS (Rollover Protective Structure) offered by Caterpillar for the machine meets ROPS criteria SAE J1040 MAY94, ISO 3471:1994.
- FOPS (Falling Object Protective Structure) meets SAE J/ISO 3449 APR98 Level II, and ISO 3449:1992 Level II.
- The operator Equivalent Sound Pressure Level (Leq) is 80 dB(A) when “ISO 6396:2008” is used to measure the value for an enclosed cab. This is a dynamic cycle sound exposure level. The cab was properly installed and maintained. The test was conducted with the cab doors and the cab windows closed.
- The exterior sound pressure level for the standard machine measured at a distance of 15 meters according to the test procedures specified in SAE J88 APR95, mid-gear-moving operation, is 92 dB(A).

# D10T Track-Type Tractor Specifications

## Dimensions

All dimensions are approximate.

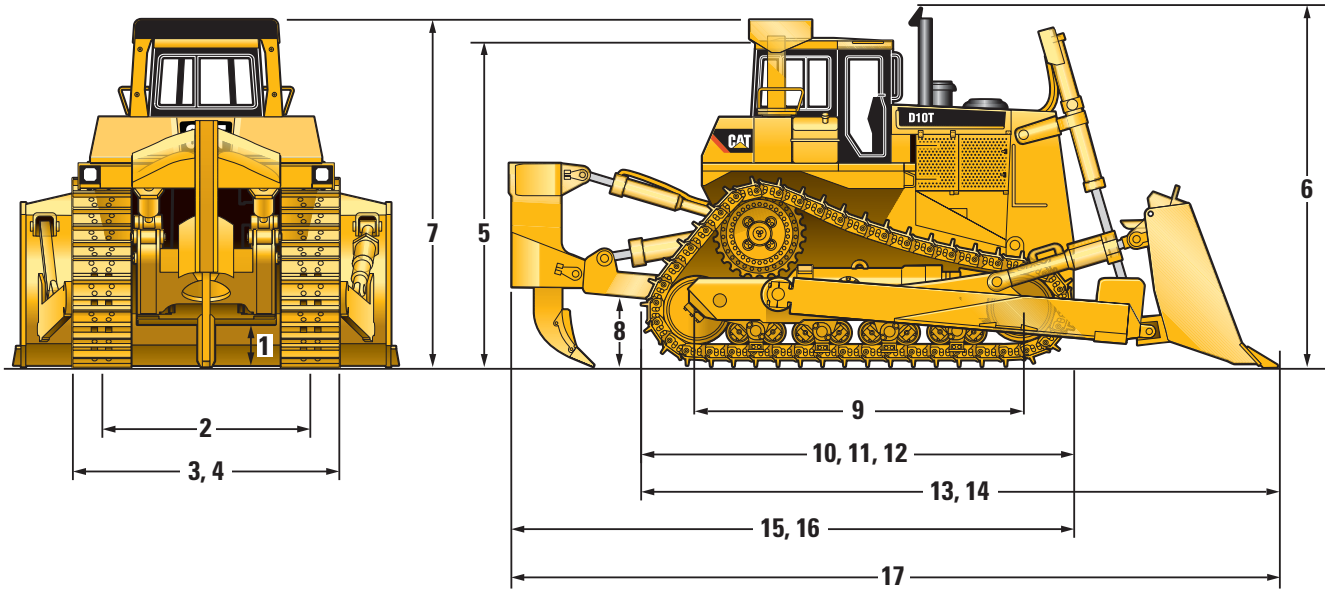

<b>1</b> Ground Clearance	664 mm	26.1 in
<b>2</b> Track Gauge	2550 mm	100.4 in
<b>3</b> Width without Trunnions (Standard Shoe)	3292 mm	129.6 in
<b>4</b> Width Over Trunnions	3736 mm	147.1 in
<b>5</b> Height (FOPS Cab)	4098 mm	161.3 in
<b>6</b> Height (Top of Stack)	4505 mm	177.4 in
<b>7</b> Height (ROPS/Canopy)	4354 mm	171.4 in
<b>8</b> Drawbar Height (Center of Clevis)	864 mm	34.0 in
<b>9</b> Length of Track on Ground	3872 mm	152.4 in
<b>10</b> Overall Length Basic Tractor	5339 mm	210.2 in
<b>11</b> Overall Length Basic Tractor (with Drawbar)	5659 mm	222.8 in
<b>12</b> Overall Length Basic Tractor with Winch	5744 mm	226.1 in
<b>13</b> Length with SU-blade	7416 mm	292.0 in
<b>14</b> Length with U-blade	7750 mm	305.1 in
<b>15</b> Length with Single-Shank Ripper	7081 mm	278.8 in
<b>16</b> Length with Multi-Shank Ripper	7241 mm	285.1 in
<b>17</b> Overall Length (SU Blade/SS Ripper)	9158 mm	360.6 in



Standard equipment may vary. Consult your Cat dealer for details.

## ELECTRICAL

Alternator, 95-amp  
Back-up alarm  
Batteries, 12-volt (2), 200 amp-hour, maintenance free  
Converter, 12-volt, 10-amp  
Diagnostic connector  
Horn, forward warning  
Light, engine compartment  
Lighting system, Halogen (2 forward, 2 rear)  
Starting receptacle

## OPERATOR ENVIRONMENT

Advisor-electronic monitoring system  
Armrest, adjustable  
Cab, FOPS  
Controls, electronic implement  
Decelerator pedal  
Finger Tip Control (FTC) steering  
Governor switch, electronic  
Heater and ventilation  
Hydraulic system, electronically controlled for bulldozer control  
Mirror, rearview  
Radio ready  
Seat, adjustable contour suspension (gray fabric)  
Seat belt, retractable 76 mm (3 in)  
Steps, heavy-duty and Handles  
Wipers, intermittent

## UNDERCARRIAGE

610 mm (24 inch) extreme service grouser with sealed and lubricated PPR track (44 section)  
Rollers and idlers, lifetime lubricated  
Sprocket rim segments, replaceable  
Suspension-type undercarriage, Eight-roller tubular track roller frame  
Track adjusters, hydraulic  
Track guides  
Two-piece master links

## POWER TRAIN

C27 with ACERT Technology  
24-volt electric start  
Advanced Modular Cooling System  
Aftercooler, remote air-to-air  
Air filters, dual with precleaner  
Controlled throttle shifting  
Coolant, extended life  
Directional shift management  
Ether starting aid, automatic  
Fan, suction with hydraulic demand drive  
Fuel priming pump, electric  
Mufflers, dual, with rain cap  
Parking brake, electronic  
Prescreener  
Separator, water/fuel  
Thermal shields  
Torque divider  
Transmission, powershift, ECPC, (3F/3R speeds)  
Four planet, double-reduction planetary final drives

## OTHER

Auto-blade assist (for dual tilt)  
CD ROM parts book  
Ecology drains  
Engine enclosures  
Grade control ready  
Guards:  
Bottom, hinged extreme service  
Crankcase, hinged extreme service  
Pivot shaft and seals  
Radiator, with towing device  
Implement gear pump compatible for arctic conditions  
Product Link ready  
Vandalism protection

# D10T Optional Equipment

Optional equipment may vary. Consult your Cat dealer for details.

## ELECTRICAL

Alternator, 95A Ducted  
Converter, 24V to 12V additional 15A  
Supplemental lights:  
6 Halogen  
10 Halogen (3 variations)  
11 Halogen (6) and HID (5)

## GUARDS

Dozer tilt lines  
Fan  
Final drive (2 variations)  
Power train  
Undercarriage  
Rear screen

## OPERATOR ENVIRONMENT

Air conditioner (3 variations)  
Visibility Arrangement (camera and mirrors)  
Glass:  
Dual pane with precleaner  
276 kPa (40 psi) with precleaner  
Operators arrangement  
(improves comfort for smaller operators)  
Seat, vinyl  
Seat, air suspension

## POWER TRAIN

Reversible cooling fan  
Fast fuel system  
Quick oil change system  
Engine prelube  
High debris radiator

## UNDERCARRIAGE

Tracks, sealed and lubricated:  
710 mm (28 in) PPR Extreme service  
786 mm (31 in) PPR Extreme service  
Rollers:  
Carrier rollers, pin-on

## SPECIAL ARRANGEMENTS

Cold weather arrangement  
Stockpile arrangement  
Waste handling arrangement

## BULLDOZER ATTACHMENTS

AutoCarry system  
Dual tilt  
10SU Blade  
10SU Abrasion resistant blade  
10U Blade  
10U Abrasion resistant blade  
AccuGrade system

## RIPPER ATTACHMENTS

Single shank (standard)  
Single shank (deep)  
Multi shank (standard)  
Multi shank (deep)  
Pin puller (single shank only)  
Push block (single shank only)

## OTHER ATTACHMENTS

Counterweights:  
Rear with hitch  
Front  
Drawbar  
Winch (dealer installed)  
Heater, engine coolant (2 variations)  
Low temperature start  
Sound suppression (2 variations)  
Slope and side-slope monitor  
Computer aided earthmoving system











# D10T Track-Type Tractor

For more complete information on Cat products, dealer services, and industry solutions, visit us on the web at [www.cat.com](http://www.cat.com)

© 2010 Caterpillar Inc.  
All rights reserved

Materials and specifications are subject to change without notice. Featured machines in photos may include additional equipment. See your Caterpillar dealer for available options.

CAT, CATERPILLAR, SAFETY.CAT.COM, their respective logos, "Caterpillar Yellow" and the "Power Edge" trade dress, as well as corporate and product identity used herein, are trademarks of Caterpillar and may not be used without permission.

AEHQ6029 (01-2010)  
Replaces AEHQ5592-01

**CATERPILLAR**<sup>®</sup>

*Courtesy of Machine.Market*