

# D3K2

## Track-Type Tractor



### Engine

Engine Model*	Cat® C4.4 ACERT™	
<b>Rated Net Power at 2,200 rpm</b>		
SAE J1349	59.7 kW	80 hp
ISO 9249/EEC 80/1269	59.7 kW	80 hp

### Weights

Operating Weight – XL	7958 kg	17,544 lb
Operating Weight – LGP	8403 kg	18,525 lb
Operating Weight – LGP, 762 mm (30 in)	8609 kg	18,980 lb

\*Engine meets U.S. EPA Tier 4 Interim/EU Stage IIIB/Japan MLIT Step 4 emission standards.

# Simply the smoothest finish grading tractor in the industry. Period.



## Contents

Operator Station.....	4
Hydrostatic Transmission.....	6
Engine.....	6
Undercarriage.....	7
AccuGrade™ Systems.....	8
Blade and Attachments.....	9
Serviceability and Customer Support.....	10
Specifications.....	11
Standard Equipment.....	14
Optional Equipment.....	15



Experience the most intuitive finish grading tractor in the industry. The Cat® D3K2 Track-Type Tractor with Stable Blade delivers a smooth finish grade with less operator effort. Stable Blade senses ground conditions and works with the operator to produce the desired grade. The addition of the integrated AccuGrade™ grade control system helps you get to target grade even faster, with fewer passes and less manpower. From the first cut to finish grade, the D3K2 sets the standard.

# Operator Station

Everyone can get comfortable in this cab.



## Seat-Mounted Joystick Controls

Ergonomically designed, seat-mounted controls isolate vibrations from the operator for optimum comfort and precise control.

- New contoured armrest cushion
- Bi-directional transmission shifting
- Easy to grip handles
- New heated control handles (optional)



### **Stable Blade Control**

New Stable Blade control makes operating the machine easy for both new and experienced operators.

- Stable Blade complements operator input for smooth finish grading results
- Handle fits to hand to allow for more precise control and reduce operator fatigue
- Thumb roller for low effort blade angle control
- Blade shake feature for easy removal of material

### **All Day Comfort**

The spacious, comfortable cab helps keep you relaxed and productive throughout the day.

- Quiet environment – 78 dB(A) – ANSI/SAE J1166 OCT98
- Wide door openings for easy entry/exit
- Dash mounted air vents for improved air circulation
- Air suspension seat for a more comfortable ride
- Air conditioning for greater comfort in all climates
- New ventilated seat (optional)
- Heated seat and heated control handles (optional)

### **Monitoring Package**

Easy to read display provides vital system information. Easy to read gauges keep you informed of system conditions. Larger AccuGrade™ CB460 GPS display is available as an option and is mounted in line with blade corners for easy viewing.

### **Outstanding Visibility**

Large door windows provide an unobstructed view to the blade corners and cutting edge which is especially important in fine grading, curbing and working against foundations. Large side windows offer a clear view to the sides of the machine.



# Hydrostatic Transmission

Responsive to changing loads.



## Traction Control

Increase your productivity with the new Traction Control feature:

- Reduces track slippage
- Activated with a button on the transmission control
- Reduces undercarriage wear
- Improves fuel economy

## Performance

Quick response to varying loads for shorter cycle times and less operator fatigue.

## Maneuverability

- Intuitive control helps you work in tight areas
- Power turn feature provides power to both tracks while working in confined areas
- Counter-rotation provides quick steering corrections during side loading applications

# Engine

Increased horsepower, improved fuel economy.

## Cat C4.4 Engine

The C4.4 engine responds quickly to changing loads. Eco mode throttle setting can deliver up to 25% improved fuel economy. Engine meets U.S. EPA Tier 4 Interim, EU Stage IIIB and Japan MLIT Step 4 emission standards using a passive regeneration solution:

- Simple...no operator interaction required
- Long life diesel particulate filter (no service required for 8,000 hours)





# Undercarriage

Solutions to lower your costs per hour.

## Choice of Undercarriage Configurations to Meet Your Application

Track frames are available in extra long (XL) or low ground pressure (LGP) configurations:

- XL undercarriage for most applications where flotation and side stability are not extreme
- LGP undercarriage for soft underfoot conditions where additional flotation is required
- 762 mm (30 in) LGP undercarriage available for extremely soft underfoot conditions

## Track Selections

Caterpillar offers a choice of two undercarriages – Sealed and Lubricated Track (SALT) and SystemOne™.

Matching the correct undercarriage to the application and soil conditions will deliver the lowest costs per hour.

### • Sealed and Lubricated Track (SALT) Undercarriage

- For applications where the track is not bushing limited
- May require pin and bushing turn

### • SystemOne™ Undercarriage

- For applications where track is bushing limited
- Bushing rotates continuously
- Does not require bushing turn
- Designed to maximize the life of all undercarriage components

# AccuGrade™ Systems

Grade with increased accuracy.



## Improve Your Efficiency with AccuGrade

AccuGrade is a fast machine grade control system which enables operators to cut and fill to grade with increased accuracy, minimizing the need for traditional stakes and grade checkers. Caterpillar offers a choice of Laser, GNSS or Universal Total Station solutions:

- **AccuGrade Laser** – for two dimensional flat type work
- **AccuGrade GNSS** – for three dimensional cut to contour work
- **Universal Total Station** – for fine and finish grade applications

## New Larger Displays

Easy to read, large displays let you focus on your work:

- **CB450 Laser Display**
  - Larger 109 mm (4.3 in) color display
- **CB 460 GNSS Display**
  - Larger 178 mm (7 in) color display
  - USB data port
  - 3.7 gig internal disk space





# Blade and Attachments

Power pitch blade for maximum productivity.

## Power Pitch Blade

The power pitch blade feature lets the operator adjust the blade pitch to meet various operating conditions without ever leaving the cab.

- Pitch the blade forward for increased penetration
- Lay the blade back for maximum carrying capacity
- Change the pitch from inside the cab
- Optimize blade pitch for application
- Improves productivity

## VPAT Blade

The VPAT blade is specifically designed for finish grading, backfilling ditches, cutting V ditches, windrowing, fill spreading, medium land clearing and heavy dozing. Built for rugged strength and durability this 6-way blade allows for maximum angle, tilt and pitch.



## Hydrostatic Winch

The Cat hydrostatic winch features:

- Excellent line pull at any speed
- Infinitely variable drum speed
- Lower operator effort
- Unmatched load control

## Parallelogram Ripper

The aggressive parallelogram ripper lets you do more productive ripper work. The parallel linkage design provides better penetration and maneuverability in tight working areas.

## Forestry Options

An easier way to work in the woods. The following features are available for forestry applications:

- Cat hydrostatic winch
- 360 degree guarding, for added protection of the cab
- Heavy-duty rear tank guard



# Serviceability and Customer Support

Easy service and unmatched support keep you working.

## Easy Access

Long service intervals and easy maintenance keep the machine up and running to lower your owning and operating costs.

- Large, hinged door on the left side of the engine compartment for easy access to all regular engine maintenance points
- Grouped pressure taps for quick testing and troubleshooting of the hydraulic system
- Easy ground level access to hydraulic filters located in the left rear service compartment

## Product Link

The optional Product Link system simplifies equipment fleet tracking. Using satellite or cellular technology, the system automatically reports information such as location, machine hours, active and logged service codes and security alarms.

## Renowned Cat Dealer Support

From helping you choose the right machine to knowledgeable ongoing support, Cat dealers provide the best in sales and service.

- Preventive maintenance programs and guaranteed maintenance contracts
- Best-in-class parts availability
- Operator training to help boost your profits
- Genuine Cat Remanufactured parts
- SITECH® dealer support for grade control solutions

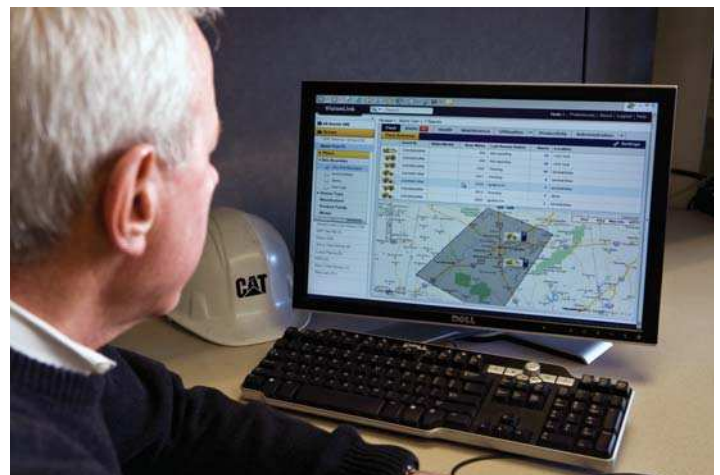

# D3K2 Track-Type Tractor Specifications

## Engine

Engine model	Cat C4.4 ACERT	
Rated Net Power @ 2,200 rpm		
SAE J1349	59.7 kW	80 hp
ISO 9249/EEC 80/1269	59.7 kW	80 hp
Bore	105 mm	4.13 in
Stroke	127 mm	5 in
Displacement	4.4 L	269 in <sup>3</sup>

- Ratings at 2,200 rpm.
- Net power advertised is the power available at the flywheel when engine is equipped with fan, air cleaner, muffler and alternator.
- No derating required up to 3000 m (9,843 ft) altitude.

## Weights

Operating weight – XL	7958 kg	17,544 lb
Operating weight – LGP	8403 kg	18,525 lb
Operating Weight – LGP, 762 mm (30 in)	8609 kg	18,980 lb

- Specifications shown are for machine equipped with dozer blade, canopy ROPS, back-up alarm, operator, coolant, lubricants and full fuel tank.

## Drawbar

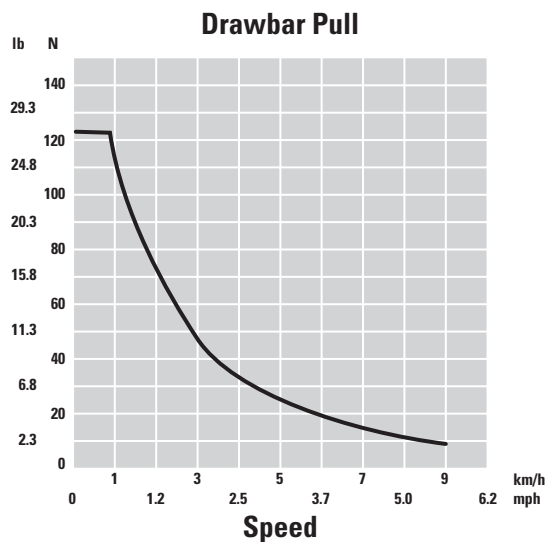

## Transmission

Drive pumps	2	
Track motors	2	
Relief valve settings	47 700 kPa	6,918 psi
Maximum travel speed – forward	9 km/h	5.6 mph
Maximum travel speed – reverse	10 km/h	6.2 mph

- Dual-path, closed loop hydrostatic drive provides infinitely variable speeds from 0-9 km/h (0-5.6 mph) forward and 0-10 km/h (0-6.2 mph) reverse.
- Full-flow filtering of hydrostatic charge system oil.
- Drive pumps: two variable-displacement, slipper-axial piston pumps mounted tandem-style to engine flywheel housing.
- Track motors: two variable-displacement, link-type piston motors.

## Service Refill Capacities

Fuel tank	195 L	51.5 gal
Crankcase and filter	11 L	2.91 gal
Final drives, XL (each side)	10 L	2.6 gal
Final drives, LGP (each side)	10 L	2.6 gal
Cooling system	22.4 L	5.92 gal
Transmission/hydraulic tank	59.5 L	15.7 gal

## Hydraulic Controls

Pump output	73.5 L/min	19.4 gal/min
Relief valve setting	20 600 kPa	2,988 psi

- Pump output ratings at 2,150 rpm and 6895 kPa (1,000 psi).
- Control positions:
  - Lift cylinders – raise, hold, lower, float.
  - Tilt cylinders – left, hold, right.
  - Angle cylinders – left, hold, right.
  - Ripper cylinders – raise, hold, lower.

## Final Drive

- Features:
- Double-reduction planetary gear set.
  - Mounted independently of track frames to isolate them from machine weight and ground-induced shock loads.

## Steering and Braking

- Features:
- Full powerturn.
  - Counter-rotation.
  - Single lever steering, speed and direction control.
  - Hydrostatic (dynamic) braking through machine drive system using transmission control lever, center brake pedal or decel pedal.

# D3K2 Track-Type Tractor Specifications

## Undercarriage

Number of rollers (each side)	6	
Number of shoes (each side) – SALT (Sealed and Lubricated Track) Undercarriage	43	
Number of shoes (each side) – SystemOne Undercarriage	38	
Shoe width – XL	406 mm	16 in
Shoe width – LGP	635 mm	25 in
Shoe width – LGP, 762 mm (30 in)	762 mm	30 in
Length of track on ground – XL	2248 mm	89 in
Length of track on ground – LGP	2248 mm	89 in
Length of track on ground – LGP, 762 mm (30 in)	2248 mm	89 in
Track gauge – XL	1495 mm	59 in
Track gauge – LGP	1725 mm	68 in
Track gauge – LGP, 762 mm (30 in)	1860 mm	73 in
Ground contact area – XL	18 254 cm <sup>2</sup>	2,829 in <sup>2</sup>
Ground contact area – LGP	28 550 cm <sup>2</sup>	4,425 in <sup>2</sup>
Ground contact area – LGP, 762 mm (30 in)	34 452 cm <sup>2</sup>	5,340 in <sup>2</sup>
Ground pressure – XL	42.8 kPa	6.2 psi
Ground pressure – LGP	30.0 kPa	4.2 psi
Ground pressure – LGP, 762 mm (30 in)	24.8 kPa	3.6 psi

- Hydraulic track adjusters.
- Box section track roller frames.
- Bolt-on rear track guiding guards.
- Full length recoil guarding with sprocket guards and wipers.
- Master link – SystemOne and SALT.
- Single-grouser shoes.
- Segmented sprocket (SALT).
- Sealed and lubricated rollers and idlers.

## Standards

Sound levels:	
ISO 6396:2008	77 dB(A)
SAE J1166 FEB2008	78 dB(A)
ROPS	SAE J397-OCT95, SAE J1040-MAY94, ISO 3471-94, ISO 3164-95
FOPS	SAE J231-JAN81, ISO 3449-92

## Ripper

Type	Parallelogram	
Number of shanks	3	
Maximum digging depth	337.5 mm	13.3 in
Maximum reach at ground line	766 mm	30.2 in
Maximum ground clearance under tip	448 mm	17.6 in
Overall width	1710 mm	67.3 in
Height	165 mm	6.5 in
Weight	554 kg	1,222 lb

## Winch

Weight	610 kg	1,345 lb
Winch drive	Hydrostatic	
Control	Hydraulic	
Speed	Variable	
Winch length	705 mm	27.76 in
Overall width	741 mm	29.2 in
Drum diameter	254 mm	10 in
Drum width	274 mm	10.8 in
Throat clearance	171.5 mm	6.75 in
Rope diameter – recommended	16 mm	0.63 in
Rope diameter – optional	19 mm	0.75 in
Drum capacity – recommended cable	113 m	371 ft
Drum capacity – optional cable	78 m	256 ft
Maximum line pull – bare drum	18 144 kg	40,000 lb
Maximum line pull – full drum	11 340 kg	25,000 lb
Maximum line speed – bare drum	40 m/min	131 ft/min
Maximum line speed – full drum	63 m/min	207 ft/min

- Infinitely variable line speed and line pull from 0 to maximum.
- Power in/power out, brake off, free spool (standard equipment).
- Single lever, low effort hydraulic control.
- Precise load control and speed modulation.
- Integral mounted drawbar.
- 3 roller fairlead available. Kit available to add a 4th roller.

## Dimensions

All dimensions are approximate.

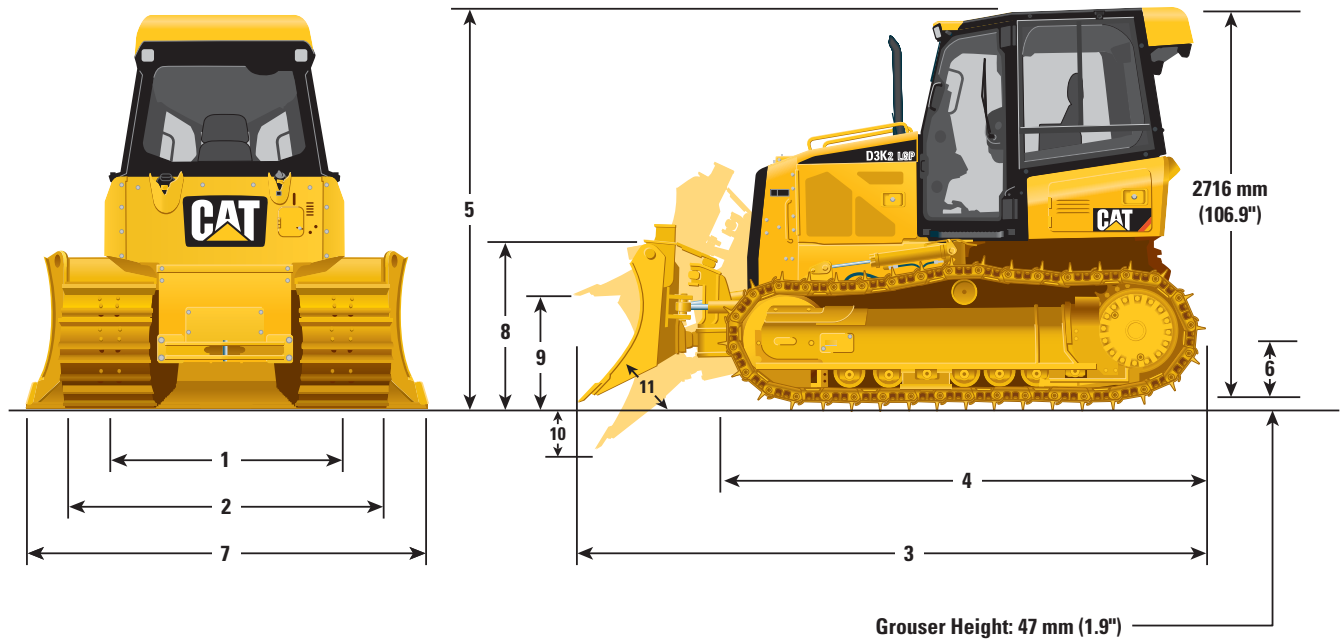

	XL		LGP		LGP, 762 mm (30 in)	
<b>1</b> Track gauge	1495 mm	58.9 in	1725 mm	67.9 in	1860 mm	73 in
<b>2</b> Width of tractor (standard shoes, no blade)	1901 mm	74.8 in	2360 mm	92.9 in	2411 mm	94.9 in
<b>3</b> Overall length (with blade)	4266 mm	168 in	4255 mm	167.6 in	4255 mm	167.6 in
<b>4</b> Length of basic tractor (without blade)	3275 mm	128.9 in	3275 mm	128.9 in	3275 mm	128.9 in
<b>5</b> Tractor height	2763 mm	108.8 in	2763 mm	108.8 in	2763 mm	108.8 in
<b>6</b> Ground clearance	332 mm	13 in	332 mm	13 in	332 mm	13 in

BLADE	XL		Intermediate		LGP	
<b>7</b> Blade width	2646 mm	104.2 in	2921 mm	115 in	3149 mm	124 in
<b>8</b> Blade height	910 mm	35.8 in	860 mm	33.9 in	860 mm	33.8 in
<b>9</b> Blade lift height	730 mm	28.7 in	743 mm	29.3 in	730 mm	28.7 in
<b>10</b> Digging depth	573 mm	22.5 in	573 mm	22.5 in	573 mm	22.5 in
<b>11</b> Blade cutting edge angle, adjustable	52° to 58°		52° to 58°		52° to 58°	
Maximum tilt	368 mm	14.5 in	448 mm	17.7 in	438 mm	17.2 in
Maximum angle (either side)	25°		25°		25°	
Blade width at maximum angle	2417 mm	95.2 in	2669 mm	105.1 in	2874 mm	113.1 in
Blade capacity (SAE)	1.52 m <sup>3</sup>	1.99 yd <sup>3</sup>	1.50 m <sup>3</sup>	1.96 yd <sup>3</sup>	1.66 m <sup>3</sup>	2.17 yd <sup>3</sup>

# D3K2 Standard Equipment

Standard equipment may vary. Consult your Cat dealer for details.

## ELECTRICAL

- Alternator, 12 volt, 120 Amp, heavy duty
- Alarm, backup
- Batteries, two, heavy duty, maintenance free, 750 CCA
- Diagnostic connector
- Horn, electric
- Lights, halogen, 2 front and 2 rear
- Starter, electric, 12 volt

## OPERATOR STATION

- ROPS/FOPS canopy
- Seat, air suspension, cloth or vinyl
- Seatbelt, retractable 76 mm (3 in)
- Foot pads, dash
- Electronic Monitoring System with:
  - Gauges for engine coolant temperature, hydraulic oil temperature and fuel level
  - Travel speed limiter, electronic
  - Engine RPM and gear display
  - Hour meter, electric
  - Engine air cleaner service indicator, electronic
  - Water-in-fuel indicator, electronic
- Throttle switch, rotary
- Eco mode
- Controls, seat mounted, fore/aft adjustment
- Armrests, adjustable
- Mirror, rearview, inside
- Single pedal combining deceleration and braking functions
- Independent forward/reverse speed settings
- Power port, 12 volt
- Coat hook
- Storage compartment
- Cup holder
- Floor mat, rubber, heavy duty

## HYDRAULICS

- Hydraulics, 3 valve
- Load sensing hydraulics
- Single lever, three function control
- Hydraulic pump and oil
- Stable blade control

## POWER TRAIN

- Cat C4.4 ACERT™ diesel engine, turbocharged, U.S. EPA Tier 4 Interim and EU Stage IIIB certified with aftertreatment
- Aftercooler, Air-to-Air (ATAAC)
- Aluminum bar plate cooling system (radiator, power train)
- Air cleaner with precleaner, automatic dust ejection and under-hood intake
- Dual path, closed-loop hydrostatic transmission
- Electric fuel priming pump
- Fuel/water separator
- Traction Control

## • UNDERCARRIAGE

- SALT Undercarriage
- 6 roller track frame
- Track rollers, lifetime lubricated
- Carrier rollers
- Track adjusters, hydraulic
- Guards, front/rear guiding
- Master link

## • OTHER STANDARD EQUIPMENT

- C-Frame, VPAT, hydraulic cylinders and lines
- Lockable engine enclosures
- Front pull device
- Rigid drawbar
- Ecology drains (engine, power train and implement oil and engine coolant)
- Scheduled oil sampling ports (engine, power train implement oil)
- Vandalism protection
- Heavy duty crankcase guard

## • ANTIFREEZE

- Extended life coolant, -37° C (-35° F)

Optional equipment may vary. Consult your Cat dealer for details.

## **ELECTRICAL**

- Integrated four front halogen lights, two rear halogen lights

## **POWER TRAIN**

- Drive, auxiliary
- Installation, winch

## **UNDERCARRIAGE**

- Track Pairs, XL:
  - Track, 406 mm (16 in) MS SystemOne™
- Track Pairs, LGP:
  - Track, 635 mm (25 in) MS SystemOne™
  - Track, 762 mm (30 in) MS SystemOne™

## **OPERATOR STATION**

- Cab with air conditioning
- Cab, polycarbonate windows and air conditioning
- Seat, air suspension, choice of:
  - Vinyl, heated seat with heated controls
  - Cloth, heated seat with heated controls
  - Cloth, heated and ventilated seat with heated controls
- Radio, AM/FM, CD player
- Sound suppression

## **HYDRAULICS**

- Hydraulics, 4 valve for use with ripper
- Hydraulics, 4 valve for use with winch

## **GUARDS**

- Guard, rear, heavy duty
- Grill, radiator, heavy duty
- Guard, track guiding, center
- Guard, track roller, full length
- Screen, rear, cab
- Screen, side, cab
- Screen, rear, canopy
- Screen, front and doors, canopy
- Sweeps, front
- Sweeps, rear

## **BLADES**

- VPAT XL blade
- VPAT LGP blade
- VPAT Intermediate blade

## **REAR ATTACHMENTS**

- Drawbar, towing
- Mounting, winch
- Ripper, parallelogram, includes three shanks and teeth

## **REAR ATTACHMENT CONTROL**

- Control, ripper
- Control, winch
- Control, ripper and winch

## **MACHINE CONTROL AND GUIDANCE**

- Installation, AccuGrade ready
- Power Pitch blade control

## **STARTING AIDS**

- Heater, engine, coolant, 120 volt
- Starting aid, ether

## **OTHER ATTACHMENTS**

- Machine Security System
- Cat Product Link 321
- Cat Product Link 121
- Cat Product Link 522

## **ANTIFREEZE**

- Extended life coolant, -50° C (-58° F)

## **FIELD INSTALLED ATTACHMENT**

- Winch, hydrostatic

# D3K2 Track-Type Tractor

For more complete information on Cat products, dealer services, and industry solutions, visit us on the web at [www.cat.com](http://www.cat.com)

© 2012 Caterpillar Inc.  
All rights reserved

Materials and specifications are subject to change without notice. Featured machines in photos may include additional equipment. See your Cat dealer for available options.

CAT, CATERPILLAR, SAFETY.CAT.COM, their respective logos, "Caterpillar Yellow" and the "Power Edge" trade dress, as well as corporate and product identity used herein, are trademarks of Caterpillar and may not be used without permission.

AEHQ6685 (03-2012)



*Courtesy of Machine.Market*