

D6N

Track-Type Tractor



Engine Model	3126B	
Rated Flywheel Power	108 kW	145 hp
Maximum Flywheel Power	127 kW	170 hp
Operating Weights		
DS – LGP arrangement	18 107 kg	39,918 lb
DS – XL arrangement	16 188 kg	35,688 lb
FTC – LGP arrangement	17 222 kg	37,968 lb
FTC – XL arrangement	15 517 kg	34,209 lb

Blade Capacity		
LGP – VPAT arrangement	3.16 m ³	4.13 yd ³
XL – VPAT arrangement	3.18 m ³	4.16 yd ³
XL – SU arrangement	4.28 m ³	5.6 yd ³

D6N Track-Type Tractor

Excellent response and control with Differential Steering deliver productivity and versatility for any job.

Power Train

- ✓ The large displacement, 3126B Caterpillar® engine features an electronically controlled, direct injection fuel system to maximize performance and provide the power you need to maximize production. The 3126B HEUI™ meets EPA Tier 2 and EU Stage II emission regulations. **pg. 4**

Undercarriage

Elevated sprocket design isolates the final drives from ground induced impacts for excellent component life. Rugged design and proven structural manufacturing assure outstanding durability. The XL or LGP configurations allow you to match the machine to specific applications. **pg. 12**

Drive Train

- ✓ Rugged, durable and reliable components deliver smooth, responsive power and lasting reliability. **pg. 5**

Serviceability

- ✓ The time between PM service intervals has been increased allowing more up-time. All major components, filters, and lube points are easily accessible and modular in design. The new updated EMS III machine monitoring system has increased diagnostic capabilities. **pg. 13**

Power Turn Differential Steering

- ✓ Power turn is supplied with Caterpillar's proven Differential Steering system. This dependable system maintains power and traction to both tracks while turning. Simultaneous control of speed, direction and steering with the tiller bar controller delivers maximum production. **pg. 6**

Engineered to excel on the most demanding work sites. Combining power, rugged components and superior balance, the versatile D6N is designed for tough working conditions. It keeps material moving with the reliability and durability you expect from Caterpillar machines.



Operator's Station

- ✓ State of the art operator's station has reduced sound levels, lower cab vibrations and good visibility. The (optional) Caterpillar comfort series air suspension seat helps to reduce operator fatigue. Cab and air conditioning are now offered as standard. **pg. 8**

Styling

- ✓ Modern styling with rounded corners, tapered engine enclosure and robust sheet metal exterior provide excellent visibility. Heavy steel access door panels and guards are easily accessible and durable. **pg. 10**

Structure

- ✓ Cast iron and heavy steel plates are welded to insure a rigid one piece case and frame structure. Bolted soft mounted cab supports reduce sound levels and vibration. Fuel and oil tank rubber isolation mounts eliminate vibration and reduce stress. **pg. 11**

Work Tools

Caterpillar offers a variety of blade designs and other work tools to tackle virtually any job quickly and efficiently. **pg. 14**

Total Customer Support

Your Cat® Dealer offers a wide range of services that can be set up with a customer support agreement. The dealer can customize a plan for you from PM service to total machine maintenance, allowing you to optimize your return on your investment. **pg. 16**



Power Train

3126B HEUI meets EPA Tier 2 and EU Stage II emission regulations and offers excellent performance levels. Differential Steering provides power turn capability and smooth steering control. Auto-shift and Auto-kickdown deliver maximum machine productivity.



Cat 3126B HEUI Engine. Caterpillar electronic engines meet worldwide emission requirements for the EPA Tier 2 and the EU Stage II regulations. With the HEUI Fuel system, injection pressure is independent of engine speed and provides maximum fuel delivery efficiency with low emissions.

The Cat 3126B engines are equipped with an electronic air inlet heater. This warms the air in the air inlet manifold for easier starting and reduces white smoke on cold starts. Machines will automatically activate the timed air inlet heater prior to engine startup.

Turbocharged and Aftercooled. A well-matched turbocharger and air-to-air aftercooler results in higher power while keeping rpm steady and exhaust temperatures low.

Torque Rise. The direct injected electronic fuel system provides a controlled fuel delivery increase as the engine lugs back from rated speed. This results in increased horsepower above rated power. A combination of increased torque rise and maximum horsepower improves response, provides greater drawbar pull and faster dozing cycles. The 127 kW (170 hp) maximum flywheel power occurs at 1600 rpm when power is needed during severe applications.

- Rated flywheel power 108 kW (145 hp).
- Maximum flywheel power 127 kW (170 hp).

3126B Engine Features. 3126B major features include:

- Increased power to 108 kW (145 hp) on both the differential steering and FTC configurations for increased performance.
- 70 percent net torque rise on the D6N differential steering machines.
- Large displacement electronic engine with lower emissions and good cold start capability.
- Power train to engine link with electronic controlled throttle shifting.
- New Poly Vee serpentine engine fan belt with auto tension feature eliminates the traditional three to four belt system.
- Extended oil and engine filter change intervals up to 500 hours after break-in.
- ATAAC cooling system.
- Multiple Row Modular (IMRM) Radiator is less subject to plugging due to a unique radiator fin design which provides excellent heat transfer capability.

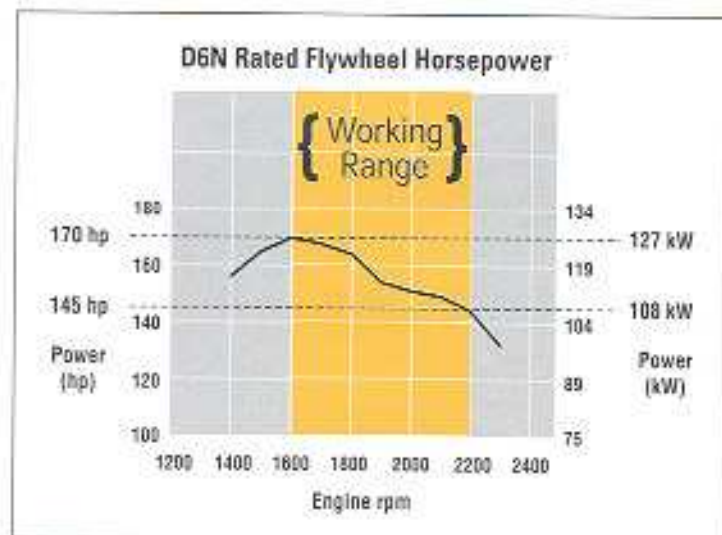

Drive Train

Rugged, durable and reliable components deliver smooth, responsive power and lasting reliability.



Torque Converter. The D6N single stage torque converter efficiently responds to changing load conditions by providing torque multiplication, therefore increasing drawbar power. It also provides protection to the drive train components by preventing shock loads in heavy dozing applications. This torque converter is efficiently matched to the power train components and provides the superior performance you need.

Auto-Shift/Auto-Kickdown. Auto-shift allows the operator to pre-select a forward and reverse gear for easy, efficient directional changes. Auto-shift settings include:

- First forward to second reverse.
- Second forward to second reverse.
- Second forward to first reverse.

Auto-kickdown allows the transmission to automatically downshift when significant load increases are detected.

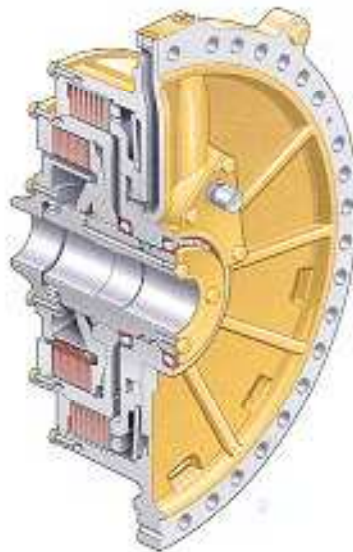

Transmission. The proven planetary powershift transmission features three speeds forward and three speeds reverse and utilizes large diameter, high capacity, oil cooled clutches. To maximize the life of the transmission, the planetary design distributes stress over multiple gears.

- Controlled throttle shifting regulates engine speed during high-energy directional shifts for smoother operation and longer component life.
- The transmission and bevel gear set are modular by design, and easily slide into the machine's rear case, even with the ripper installed.
- Forced oil flow lubricates and cools clutch packs to provide maximum clutch life.

Steering Clutch and Brakes. Oil cooled, hydraulically actuated, large diameter plates and clutch discs provide higher torque capacity and increased service life.

Elevated Final Drive. Final drives are isolated from ground and work tool induced impact loads for extended power train life.

Electronic Steering and Transmission Controls. The D6N offers both Differential Steering and Finger Tip Controls for steering. Both systems deliver the control the operators need for all applications. Soft touch buttons located on the steering controls shift the electronically controlled transmission.

Electronic Clutch Pressure Control. The D6N has an additional transmission shifting feature for added performance and operator comfort — the Electronic Clutch Pressure Control (ECPC). This unique feature provides smoother shifting by regulating and modulating the individual clutches based on current operating conditions.

Power Turn Differential Steering

A D6N equipped with differential steering maintains power to both tracks while turning. Operators have control of machine speed, direction and steering with the tiller bar controller, while maximizing production.



Tiller Bar Control System. The tiller bar control system allows for simultaneous comfortable, one-handed steering, direction and transmission control.

- The differential steering tiller bar has easy touch shift buttons for upshifts and downshifts.
- The tiller bar is easily pushed forward to steer the tractor to the left and pulled backwards to steer the tractor to the right.
- The more the tiller bar is moved, the tighter the turn.
- To change machine direction, operators rotate the tiller bar clockwise for forward or counterclockwise for reverse. Neutral transmission position is in the middle between the two.
- Low tiller bar efforts assure operator comfort during long shifts.

Power Turn with Differential Steering.

With differential steering, large blade loads can be smoothly maneuvered throughout the turn. The operator maintains precise control on slopes, around buildings, bridge abutments, trees or other obstacles.

- Differential Steering has the ability to work in tight areas by providing a "Best in Class" tight turning radius.
- Steering modulation is finely tuned for precise control in all turning applications.
- Regardless of ground conditions, steering is consistent because power is maintained to both tracks during operation.

Differential Steering System. A planetary differential turns the machine by speeding up one track and slowing the other while maintaining full power to both. The differential steering system consists of:

- Three planetary gear sets.
- A dedicated variable-displacement hydraulic pump.
- A bi-directional, fixed-displacement steering motor.
- Heavy-duty steering drive gears.
- Two planetary gear sets (steering and drive) make up the dual differential.
- A third planetary gear set, the equalizing planetary, resides in the main case and provide a maximum 4.0 m/s (2.49 mph) speed difference between tracks.

Operation. When moving straight ahead, power flows through the transmission pinion and bevel gear into the dual differential, transmitting equal, uninterrupted power to each final drive. While turning, power is shifted to the outboard track speeding it up. The inboard track slows down to accommodate a tighter turning radius. Forward ground speed remains the same throughout the turn.



1 Operator's Station – State of the art operator's station has reduced sound levels, lower cab vibration, and increased glass area.

2 Steering Control – Differential Steering Tiller Bar control system and the optional Finger Tip Control (FTC) steering system provide simultaneous one handed steering and transmission control.

3 Differential Steering Motor – Bi-directional hydraulic steering motor activates the dual differential, which increases or decreases the speed of individual tracks. Slowing one track and increasing the speed of the other track achieves a smooth power turn.

4 Powershift Transmission – Proven planetary design provides fast smooth speed changes while distributing loads over multiple gears for long life.

5 Final Drive – Caterpillar elevated final drives provide isolation from ground or work tool impact loads, extending service life.

6 Brake Assembly – Oil cooled large diameter brake disc provide long service life.

7 Engine – Caterpillar 3126B HEUI engine meets EPA Tier 2 and EU Stage II emission regulations.

8 Radiator – Improved Multiple Row Modular (MRM) radiator is less subject to plugging and provides excellent heat transfer.

9 Torque Converter – Efficient torque converter provides torque multiplication for increased drawbar pull and protects the drive train from shock loads.

Operator's Station

State of the art operator's station has reduced sound levels, lower cab vibrations and excellent visibility. The (optional) Caterpillar comfort series air suspension seat helps reduce operator fatigue. Cab and air conditioning are now offered as standard.



Cat C500 Comfort Suspension Seat. Caterpillar C500 Comfort Series Air Suspended Seat is ergonomically designed to support the operator in all site conditions (optional).

- Seat is fully adjustable for maximum operator comfort, support and reduced operator fatigue.
- Seat cushion reduces pressure on the lower back and thighs while allowing unrestricted arm and leg movement.
- A standard lumbar adjustment improves lower back comfort.

Cab. The cab incorporates large glass window and door panels. This allows for excellent visibility to the blade, rear and sides of the machine. New door and window seal design allows for a fully pressurized dust free cab. Low acoustic headliner material, and sound suppression foam panels reduce sound levels to below 76 dB(A) when measured per ISO 6394:1998.

The cooling system is now incorporated into the cab structure providing good visibility to the rear of the machine. Individual windshield wiper controls are located in the front section of the headliner. The new design is spacious and comfortable to promote shift-long productivity.



Dash. The instrument panel, with easy to read analog gauges and warning lamps, keeps the operator aware of any potential problems. All gauges and readouts are easily visible in direct sunlight. HVAC controls and vents are conveniently located on the dash to provide climate control for the operator. Auto-shift and Auto-kickdown controls are located within easy reach of the operator. New footpads keep the operator stable and comfortable during side slope applications.

Electronic Monitoring System (EMS-III).

EMS III provides the operator instant feedback on machine conditions and records performance data to help diagnose problems. It has flashable memory allowing system upgrades, as new technology and electronics become available. This system is compatible with Cat ET and CMS service tools. EMS includes the following gauges and readouts:

- Fuel level gauge.
- Hydraulic oil temperature gauge.
- Engine coolant temperature gauge.
- Power train oil temperature gauge.
- Engine oil pressure indicator.
- Engine speed digital readout.
- Transmission gear indicator.



Ergonomic Work Tool Controls.

Ergonomically shaped blade and ripper controls have improved lever efforts for reduced operator fatigue. The voltage converter provides two 12-volt power supplies.



Finger Tip Control (FTC). Located to the operator's left, finger tip controls provide one-handed operation. They control steering, machine direction and gear selection.

- Finger tip levers allow operators to work with precision in close areas.
- Push buttons control three speed forward/reverse gear selection.

Styling

Modern styling with rounded shapes and tapered hood enhances operator visibility. The N-Series combines eye-catching styling with solid, reliable performance.



Styling. New styling with rounded machine shapes offers excellent visibility, accessibility and serviceability.

- Durable, heavy steel door panel covers.
- Pre-cleaner is below the hood for good visibility.
- Engine enclosure is tapered as it reaches the cab.
- Large amount of glass area in cab.
- Controls are ergonomic for easier operation and better efficiency.

Accessibility and Serviceability.

- Hinged engine doors to increase engine and service access.
- Remote-mounted filters located within easy reach during PM service.
- Air pre-cleaner filter condition monitor located in the cab for high visibility.
- Redesigned fuel tank for easier internal cleaning.
- Fast fuel tank provision added (attachment).
- Larger service panel doors.
- Diagnostic test ports added for quick troubleshooting.

Quality and Reliability.

- Doubled 4 mm (0.16 in) sheet metal on the side service access panels and rear guard.
- Stamped, rounded sheet metal corners add strength.
- Rubber isolation mounted fuel and oil tanks eliminate tank vibration and reduce potential stress fractures.
- Heavy duty reinforced radiator guard is now standard.
- Heavy duty rear guard for ripper.
- Clipped seals provide protection from dust and moisture for:
 - rear enclosure
 - door openings
 - between ROPS post and rear enclosure

Structure

Engineered and built to give solid support in the most demanding applications. Designed to last throughout the extended service life of the D6N.



Frame and Castings. The D6N case and frames are built to absorb high impact shock loads and torsional forces. Castings are strategically located within the frame to add additional strength. Caterpillar uses robotic welding techniques in the assembly of the case and frames. This insures quality and reliability throughout the structure.

- High strength steel mainframe resists impact shock loads.
- Computer-aided finite element analysis is used to evaluate and ensure durability.
- Full scale structural testing to test integrity of the structures.
- Robotic welding provides deep penetration and consistency for long life.
- Precision top level machining for perfect alignment of bores and surfaces.
- Pivot shaft and pinned equalizer bar to maintain track roller frame alignment.

Equalizer Bar. The pinned equalizer bar gives the roller frames the ability to oscillate up or down to better match ground contours while providing maximum traction and operator comfort.

Roll Over Protection Systems. N-Series cab supports have been stiffened. Stiffer ROPS supports result in lower noise and vibration in the cab, providing the operator increased comfort.



Rotating Bushing Track. Rotating Bushing Track is designed to extend system life and lower costs in highly abrasive low to moderate impact applications.

RBT features bushings which rotate when in contact with the sprocket, greatly reducing bushing and sprocket wear. This design eliminates bushing turn maintenance expense and sprocket replacement costs.

Rotating Bushing Track is available as optional undercarriage.

Undercarriage

The Caterpillar elevated sprocket undercarriage arrangements are designed for optimized balance and best possible performance in fine grading to heavy dozing applications.

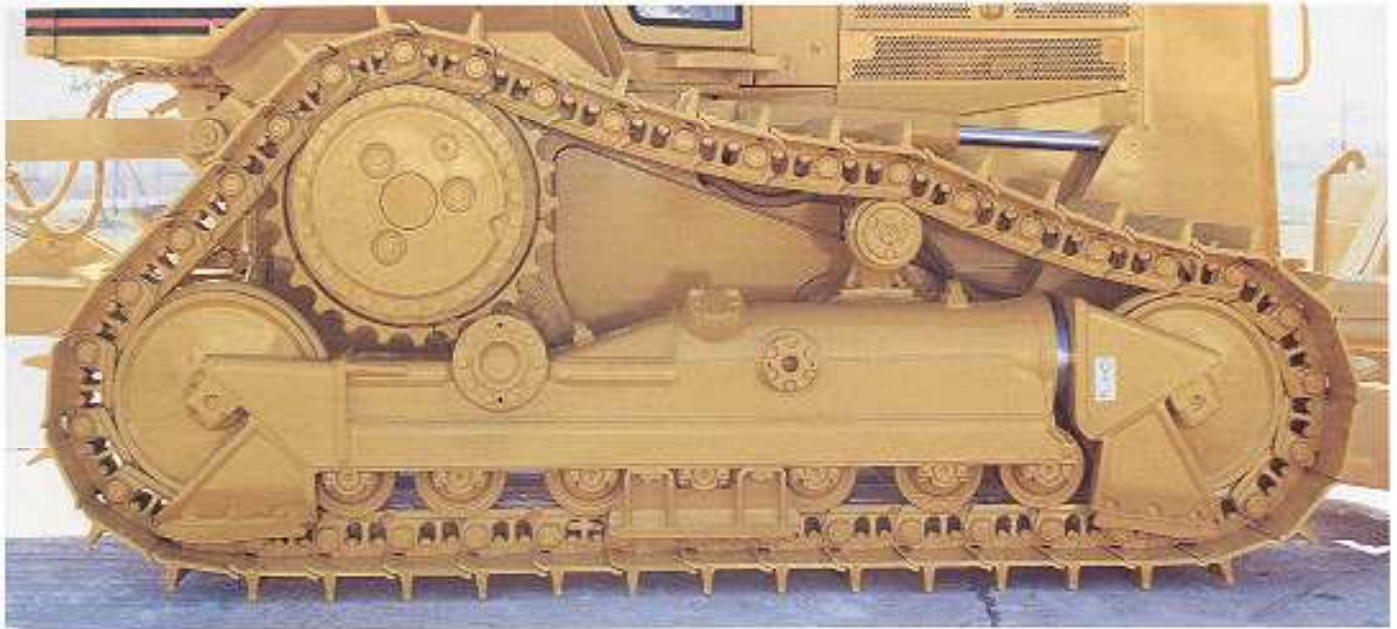

Elevated Final Drive.

- Isolates final drives from ground and work tool induced impact loads for extended power train life.
- Keeps sprocket teeth, bushings and final drives away from abrasive materials and moisture.
- Caterpillar uses single reduction planetary final drives in the D6N providing long-lasting performance and durability.

Final Drives and Associated Components.

- Final drives raised above the working area where moisture and abrasive conditions can cause premature failures and damage
- Isolates them from ground-induced impact loads.

Undercarriage Arrangements.

XL (Extra Long) arrangement

- Forward idler position provides more track on the ground and to the front of the tractor. It provides optimal balance, superior traction and blade control for finish grading.
- Long roller frame provides good flotation in soft underfoot conditions.

LGP arrangement

- Specially designed to work in soft and spongy conditions.
- Wide track shoes, long track frames and a wider gauge increase track contact area and reduce ground pressure for excellent flotation.

Complete Guarding.

Caterpillar undercarriages are designed with full length guarding on top of the track roller frame. This prevents abrasive materials from falling down on moving parts.

Roller Frames. Roller frames are tubular, to resist bending and twisting.

- Roller frames attach to the tractor by a pivot shaft and pinned equalizer bar.
- The recoil system is sealed and lubricated.

Serviceability

Modular design moves Caterpillar a generation ahead in simplifying repair and maintenance.



Product Link. This option allows the customer or dealer to obtain machine diagnostics and location from their offices. Product Link provides updates on service meter hours, machine condition, machine location as well as integrated mapping/route planning.



Electronic Monitoring System. The D6N features a more flexible monitoring system that is easily upgraded by flashing software rather than replacing the module, reducing parts cost. As technology changes and new electronics and software become available, this upgraded monitoring system will allow the machine to be easily updated.



Built-in Serviceability. Less service time means more working time. Major components are designed as modules and most can be removed without disturbing or removing other components.

Diagnostic Connector. Diagnostic connector allows Caterpillar dealers to quickly troubleshoot the D6N or access stored data with the use of Electronic Technician (Cat ET).

Ecology Drains. Ecology drains provide an environmentally safer method to drain fluids. They are included on the radiator, hydraulic tank and major power train components.

Modular Cooling System. Individual radiator core modules are easily serviced without major component removal.

Easy Engine Maintenance. Many parts can be rebuilt and are available as remanufactured components.

- Parent-metal block can be rebored twice and dry-sleeved.
- Connecting rods can be removed through cylinder tops.
- Camshaft followers and push rods can be replaced without removing camshaft.
- Extended oil and engine filter change intervals up to 500 hours.

Work Tools

Cat D6N work tools are designed to provide strength and flexibility to match the machine to the job.



Caterpillar Blades. With superior moldboard and 4-cell structure design, Cat bulldozer blades hold up to the toughest job conditions. Our high-tensile strength blades resist torsional bending and deflection in tough applications.

- High-tensile strength, Cat DH-2™ steel, cutting edges resist bending.
- DH-3™ steel end bits maximize service life.

Variable Pitch Power Angle and Tilt Blade (VPAT). The VPAT blade gives the operator the ability to hydraulically adjust the blade lift, angle and tilt from the operator's station.

- Manually adjustable blade pitch for optimum performance.
- Top corners of the blade are clipped for better operator viewing area. (XL arrangement only).
- C-Frame is solidly pinned to the main frame for good blade control and eliminates blade motion due to track oscillation or side forces.

- C-Frame has been moved closer to the front of the machine to improve fine grading and blade control.
- C-Frame to tractor joint is sealed and lubricated with remote lines for extended service life and quiet operation.
- Large C-Frame tower bearings have been added to improve durability.
- Lubrication points are located at all pin joints to reduce wear.



Semi-Universal Blade (XL Arrangement Only). Built for tough applications where penetration and blade side loading are important. The design of the SU blade makes it excellent for aggressive dirt penetration and loading materials. The blade wings are designed for superior load retention.

Foldable Blade (D6N LGP Arrangement Only). Designed to conform with the 3 m (9.8 ft) width transport limit without blade removal. Allows a 0.30 m (1 ft) section on both ends of the blade to fold into transport position.



Multi-Shank Ripper. The multi-shank parallelogram ripper lets you choose one, two or three shanks depending on job conditions.

- Curved or straight ripper shanks are available.
- Excellent chassis durability in severe drawbar applications.

Drawbar. The D6N can be equipped with a drawbar for pulling work tools such as:

- Disks.
- Compactors.
- Chopper wheels.
- Retrieval of other equipment.

Winch.

- Single lever control actuates both clutch and brake functions for excellent operator efficiency.
- Input clutches on PTO shaft reduce engine horsepower loss for fuel efficiency.
- Clutch engagement and brake release are automatically synchronized for smooth operation.
- Winch components can be serviced with winch mounted on tractor.
- Check with your Caterpillar Dealer for winch selection details.



Forestry Sweeps. In forestry and land clearing applications where limbs and debris can damage a machine, optional sweeps are available for the N-Series. Sweeps help to shield critical components on the tractor such as hydraulic lines, exhaust stacks, cab windows and lights from damage.

Rear Counterweight. Rear counterweights are available and can be used to help the machines balance in severe applications such as backing up slopes or heavy angle dozing.

Total Customer Support

Your Cat Dealer offers a wide range of services that can be set up with a customer support agreement. The dealer can customize a plan for you from PM service to total machine maintenance, allowing you to optimize your return on investment.



Product Support. Your Cat Dealer offers a wide range of services that can be set up under a customer support agreement when you purchase your equipment. The dealer will help you choose a plan that can cover everything from the machine and attachment selection to replacement. This will help you get the best return on your investment.

Remanufactured Components.

Save money with remanufactured parts. You receive the same warranty and reliability as new products at a cost savings of 40 to 70 percent.

Service Capability. Whether in the dealer's fully equipped shop or in the field, you will get trained service technicians using the latest technology and tools.

Selection. Make detailed comparisons of the machines you are considering before you buy. How long do components last? What is the cost of preventive maintenance? What is the true cost of lost production? Your Cat Dealer can give you answers to these questions.

Purchase. Consider the financing options available as well as day-to-day operating costs. This is also the time to look at dealer services that can be included in the cost of the machine to yield lower equipment owning and operating costs over the long run.

Operation. Improving operating techniques can boost your profits. Your Cat Dealer has training videotapes, literature and other ideas to help you increase productivity.

Replacement. Repair, rebuild or replace? Your Cat Dealer can help evaluate the cost involved so you can make the right choice.

Maintenance. More and more equipment buyers are planning for effective maintenance before buying equipment. Choose from your dealer's wide range of maintenance services at the time of your purchase. Repair option programs guarantee the cost of repairs up front. Diagnostic programs such as Scheduled Oil Sampling and Technical Analysis help avoid unscheduled repairs.

Engine

Engine Model	3126B	
Rated Flywheel Power - DS	108 kW	145 hp
Rated Flywheel Power - FTC	108 kW	145 hp
Maximum Flywheel Power - DS	127 kW	170 hp
Maximum Flywheel Power - FTC	127 kW	170 hp
Net Power - ISO 9249	108 kW	145 hp
Net Power - SAE J1349	108 kW	145 hp
Net Power EU 60/1269	108 kW	145 hp
Bore	110 mm	4.33 in
Stroke	127 mm	5 in
Displacement	7.2 L	439 in ³

- Engine Ratings at 2200 rpm.
- Net power advertised is the power available at the flywheel when the engine is equipped with fan, air cleaner, muffler and alternator.
- No derating required up to 4600 m (15,100 ft) altitude, beyond 4600 m (15,100 ft) automatic derating occurs.

Transmission

	D6N FTC		D6N DS	
1 Forward	3.3 kph	2.0 mph	3.3 kph	2 mph
2 Forward	5.8 kph	3.6 mph	5.7 kph	3.5 mph
3 Forward	10.0 kph	6.2 mph	9.7 kph	6 mph
1 Reverse	4.0 kph	2.5 mph	4 kph	2.5 mph
2 Reverse	7.2 kph	4.4 mph	7 kph	4.3 mph
3 Reverse	12.3 kph	7.6 mph	12 kph	7.4 mph

Weights

Operating Weight Power Shift FTC - XL	15 517 kg	34,209 lb
Operating Weight Power Shift FTC - LGP	17 222 kg	37,968 lb
Operating Weight Power Shift DS - XL	16 188 kg	35,688 lb
Operating Weight Power Shift DS - LGP	18 107 kg	39,918 lb
Shipping Weight FTC - XL	15 185 kg	33,477 lb
Shipping Weight DS - XL	15 856 kg	34,956 lb
Shipping Weight FTC - LGP	16 890 kg	37,236 lb
Shipping Weight DS - LGP	17 775 kg	39,186 lb

- Shipping Weight
Includes EROPS, A/C, lights, VPAT dozer, transmission, drawbar, engine enclosure, 3 valve hydraulics, 5% fuel and C500 Comfort Seat.
- Operating Weight
Includes EROPS, A/C, lights, VPAT dozer, transmission, drawbar, engine enclosure, 3 valve hydraulics, 100% fuel, C500 Comfort Seat and operator.

Undercarriage - Std.

Number Shoes Side - XL	40	
Number Shoes Side - LGP	46	
Track Rollers/Side - XL	7	
Track Rollers/Side - LGP	8	
Width of Shoe - XL	610 mm	24 in
Width of Shoe - LGP	860 mm	34 in
Track on Ground - XL	2550 mm	100 in
Track on Ground - LGP	3102 mm	122 in
Track Gauge - XL	1890 mm	74 in
Track Gauge - LGP	2160 mm	85 in
Ground Contact Area - XL	3.11 m ²	4,822 in ²
Ground Contact Area - LGP	5.34 m ²	8,269 in ²
Ground Pressure (Std) - XL FTC	48.9 kPa	7.09 psi
Ground Pressure (Std) - LPG FTC	31.7 kPa	4.59 psi
Ground Pressure (Std) - XL DS	51.1 kPa	7.40 psi
Ground Pressure (Std) - LGP DS	33.3 kPa	4.83 psi

Service Refill Capacities

Fuel Tank	299 L	79 gal
Cooling System	54 L	14.2 gal
Final Drives (each)	7 L	1.8 gal
Hydraulic Tank	29.5 L	7.8 gal

Blades

Blade Type	V PAT SU
------------	-------------

Multi-Shank Ripper

Type	Fixed Parallelogram
Beam cross section	216 × 254 mm 8.5 × 10.0 in
Number of pockets	3

Winch Specifications

Winch Model	PA 55
Weight	1276.5 kg 2,814 lb
Winch and Bracket Length	1120 mm 44.1 in
Winch Case Width	975 mm 38.4 in
Flange Diameter	504 mm 19.8 in
Drum Width	330 mm 13 in
Drum Diameter	254 mm 10 in
Drum Capacity - 22 mm (0.88 in)	68 m 289 ft
Ferrule Size (O.D. × Length)	54 × 65 mm 2.13 × 2.56 in
Oil Capacity	74 L 19.55 gal

Standards

- ROPS (Rollover Protective Structure) offered by Caterpillar for the machine meets ROPS criteria SAE J397 OCT95, SAE J1040 MAY94, ISO 3184 1995 and ISO 3471-11994.
- FOPS (Falling Object Protective Structure) meets SAE J231 JAN 81 and ISO 3449 1992 Level II.
- The operator sound exposure Leq (equivalent sound pressure level) measured according to the work cycle procedures specified in ANSI/SAE J1166 OCT 98 is 82 dB(A), for cab offered by Caterpillar, when properly installed and maintained and tested with the doors and windows closed.
- Hearing protection may be needed when operating with an open operator station and cab (when not properly maintained or doors/windows open) for extended periods or in noisy environment.
- The exterior sound pressure level for the standard machine measured at a distance of 15 meters according to the test procedures specified in SAE J88 JUN86, mid-gear-moving operation, is 82 dB(A).
- Brakes meet the standard SAE J/ISO 10265 MARCH99.

Dimensions (approximate)

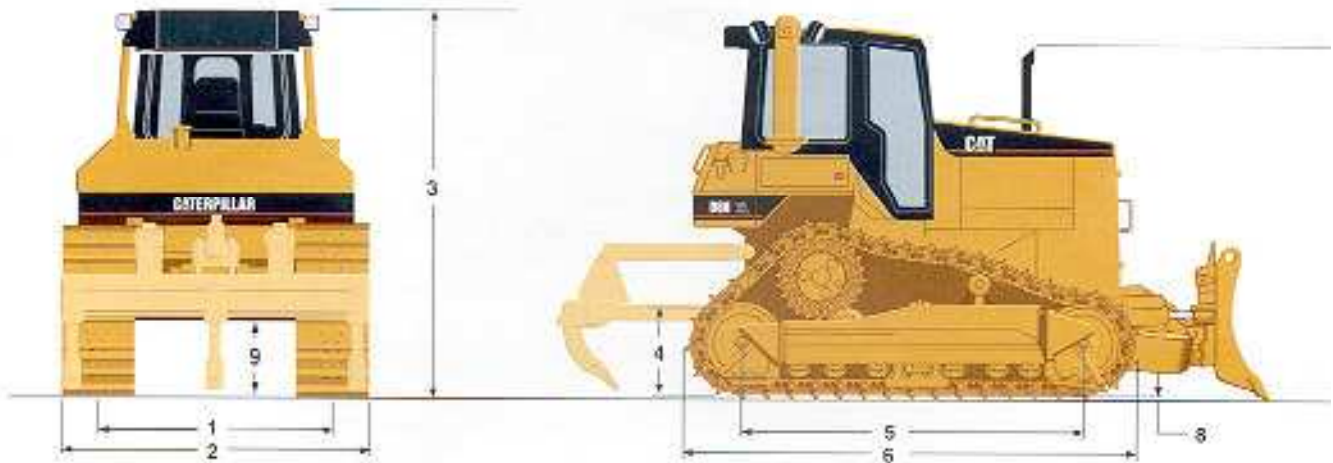

Tractor Dimensions

	XL		LGP	
1 Track gauge	1890 mm	74 in	2160 mm	85 in
2 Width of tractor				
With the following attachments:				
Standard shoes without blade	2492 mm	98 in	3022 mm	119 in
840 mm (33") shoes without blade	—	—	3000 mm	118 in
Standard shoes with VPAT blade angled 25°	2960 mm	117 in	3700 mm	146 in
3 Machine height from tip of grouser:				
With the following equipment:				
ROPS canopy	3022 mm	119 in	3136 mm	123 in
ROPS cab	3083 mm	121 in	3197 mm	126 in
4 Drawbar height (center of clevis)				
From ground face of shoes	595 mm	23.4 in	710 mm	27.9 in
5 Length of track on ground	2550 mm	100 in	3102 mm	122 in
6 Length of basic tractor (with drawbar)	3740 mm	147 in	4149 mm	163 in
With the following attachments, add to basic tractor length:				
Ripper	1026 mm	41 in	1026 mm	41 in
PA55 winch	381 mm	15 in	381 mm	15 in
VPAT blades, straight	1057 mm	42 in	1244 mm	49 in
VPAT blade, angled 25°	1787 mm	70 in	2125 mm	84 in
SU blade	1176 mm	46 in	—	—
7 Height over stack from tip of grouser	2886 mm	114 in	3000 mm	118 in
8 Height of grouser	57 mm	2.2 in	57 mm	2.2 in
9 Ground clearance from ground face of shoe (per SAE J1234)	424 mm	16.7 in	538 mm	21.2 in

Bulldozer Specifications

		(XL) 6 VPAT Blade	(XL) 6SU Blade	(LGP) 6 VPAT Blade
Blade capacity (SAE J1265)	m ³	3.18	4.28	3.16
	yd ³	4.16	5.6	4.13
Blade width (over end bits)	mm	3274	3190	4080
	in	129	125.6	160.6
Blade height	mm	1195	1244	1025
	in	47	49	40.4
Digging depth	mm	538	520	433
	in	21.1	20.5	17.0
Ground clearance	mm	822	983	1024
	in	33	38.7	40.3
Maximum tilt	mm	497	665	598
	in	20	26.2	23.5
Weight (without hyd. controls)	kg	2372	2427	2819
	lb	5229	5351	6215

Ripper

		XL	LGP
Beam width	mm	2202	2202
	in	86.7	86.7
Cross section	mm	216 × 254	216 × 254
	in	8.5 × 10	8.5 × 10
Ground clearance under beam (raised)	mm	1090	1205
	in	42.9	47.4
Under tip at full raise	mm	391.7	505.7
	in	15.4	19.9
Number of pockets (teeth)	in	3	3
Maximum penetration	mm	473.5	359.5
	in	18.6	14.2
Maximum pryout force	kg	126 000	126 000
	lb	28,350	28,350
Maximum penetration force (VPAT blade equipped power shift)	kg	60 230	71 980
	lb	13,550	16,195
Weight:			
With three teeth	kg	1406	1406
	lb	3100	3100
Each tooth	kg	78	78
	lb	172	172

Standard Equipment

Standard equipment may vary. Consult your Caterpillar dealer for details.

Electrical

- 10-amp/12-volt converter
- 70-amp alternator
- Back-up alarm
- Diagnostic connector
- Horn
- Hour meter
- Integrated front lights

Operator Environment

- Coat hook
- Cup holder
- Electronic Monitoring System (EMS-III)
- Electronic travel speed and gear limiter
- Engine air cleaner service indicator in the cab
- Engine RPM display/gear display
- Foot pegs for slope work
- Four gauge cluster
- FTC control for Clutch and Brake steering or
Cat tiller bar for D/S
- Mirror, rearview
- Power points, two 12-volt
- Pre-start coolant level monitoring system
- Product link ready
- Radio ready, 12-volt
- ROPS/FOPS cab with integrated A/C
- Seat belt, retractable 76 mm (3 in)
- Storage and literature compartments
- Transmission shift points selection function on dash

Power Train

- 3126B HEUI Caterpillar diesel engine with 24-volt starter
- Air-to-air aftercooler
- Auto-dust ejector with under hood air filter and pre-screener
- Automatic down-shift and kickdown transmission control
- Controlled throttle shifting
- Coolant, extended life
- Coolant sampling port
- Decelerating function
- Fan, blower
- Fuel/water separator
- Load compensated shifting
- Modular radiator (IMRM)
- Selectable shift points
- Single poly-vee belt with automatic belt tensioner
- Steering system: Clutch and Brake with FTC or optional
Differential Steering system
- Three-speed planetary transmission with torque converter

Undercarriage

- Adjuster, hydraulic track
- Carrier rollers
- Guards, end track guiding
- Heavy-duty sealed and lubricated tracks
- Idlers, lifetime lubricated
- Rollers, lifetime lubricated track
- Wider tread and taller flange idler profile

Other Standard Equipment

- 4600 meter altitude operation capability without derating
- Centralized remote mounted pressure taps for easy access
and diagnostics
- Crankcase guard
- Ecology drains
- Extended service intervals (500 hours)
- Front pull device
- Hinged engine doors
- Hinged radiator grill
- Implement oil filter
- Keyed lockable enclosures
- Load sensing hydraulics
- Rigid drawbar
- S•O•SSM taps for engine, transmission and implement fluids
- Three valve hydraulics for VPAT dozer
- Transmission remote pressure taps

Optional Equipment (with approximate change in operating weight)

Standard and optional equipment may vary. For specific tractor applications, additional guarding may be required. Consult your Caterpillar dealer for specifics.

	kg	lb
Air conditioner less off	-51.4	-113.3
Alternator, brushless	0.34	0.7
Bulldozers – See Bulldozer Specifications chart for weights		
Canopy	-150	-330.7
Heater, dash mounted for OROPS	18.5	40.8
Fan, reversible	3.7	8.2
Fast fill fuel tank	7	15.4
Lighting system, 4 lights	18.2	40.1
Rotating beacon	3.3	7.3
Sound suppression (for cab)	18	39.7
Product link	4	8.8
Protective MSS	2.5	5.5
Guards:		
Crankcase, heavy duty	80	176.4
Fuel tank (for cab or canopy)	72	158.7
Guard, rear, heavy duty	5	11.0
Guiding Track XL/MS	167	368.2
Guiding Track LGP/MS	73	160.9
Guiding Guarding Track XL/HD	250	551.1
Guiding Guarding Track LGP/HD	198	436.5
Radiator, heavy duty, hinged grill	30	66.1
Sand blast grid	18	39.7
Screens and Sweeps:		
Rear screen for EROPS cab	81	178.6
Rear screen for OROPS canopy	53	116.8
Sun screen	5	11.0
Sweeps EROPS	133.1	293.4
Sweeps OROPS	143.2	315.7
Hydraulics and Ripper:		
Three valve for SU blade (XL) and ripper (valve itself)	0	0
Four valve for 6VPAT bulldozer and ripper (valve itself)	23	50.7
Ripper, parallelogram (with three straight teeth)	1406	3099.6
Each optional curved tooth, replacing straight tooth	78	172.0

ES: Extreme Service shoes, MS: Moderate Service shoes
 HD: Heavy Duty link track, RBT: Rotating Bushing Track

	kg	lb
Seat (adjustable armrest on FTC versions only):		
Air suspended C500 comfort series, cloth (for cab only)	52.4	115.5
C500 comfort series, cloth, mechanical suspended (for cab only)	53.6	118.2
C500 comfort series, vinyl, mechanical suspended	53.6	118.2
Low back, vinyl	48.7	107.4
Starting aids:		
Engine coolant heater (dealer installed)	1	2.2
Heavy duty batteries	45	99.2
Priming pump	0	0
Track, pair, heavy duty sealed and lubricated:		
XL arrangement, 40-section:		
560 mm (22") MS/HD	-180	-396.8
560 mm (22") MS/RBT	252	555.6
560 mm (22") ES/HD	60	132.3
610 mm (24") MS/RBT	-80	-176.4
610 mm (24") ES/HD	160	352.7
LGP arrangement, 46-section:		
710 mm (28") MS/HD	-370	-815.7
710 mm (28") MS/RBT	-60	-132.3
865 mm (34") MS/RBT	0	0
860 mm (34") self cleaning/HD	180	396.8
Winch and fairleads:		
Winch (standard or low speed)	1276.5	2814.2
Fairlead, 3 rollers	290	639.3
Fairlead, 4 rollers	320	705.5