

D6T

Track-Type Tractor



Engine

Engine Model	Cat® C9 ACERT™	
Engine Power	STD	
Engine Power – ISO 14396	152 kW	204 hp
Engine Power – ISO 14396 Metric		207 hp
Net Power – ISO 9249	138 kW	185 hp
Net Power – ISO 9249 Metric		188 hp

Engine Power	XL/LGP	
Engine Power – ISO 14396	163 kW	219 hp
Engine Power – ISO 14396 Metric		222 hp
Net Power – ISO 9249	149 kW	200 hp
Net Power – ISO 9249 Metric		203 hp

Features

Operator Station

Ease of operation, as well as cab comfort and layout, help keep operators comfortable and more productive. The D6T offers excellent visibility all around the machine, enhancing operator efficiency and job site safety.

Power Train

The D6T is powered by a Cat C9 engine with ACERT™ Technology that delivers proven performance and reliability. The electronically controlled powershift transmission, differential steering, and durable planetary final drives deliver smooth, responsive power in a variety of working conditions. Dedicated hydraulics and machine control systems help enhance productivity so operators can get more work done in less time.

Integrated Technologies

AccuGrade™ systems help improve productivity and efficiency, as well as help less experienced operators perform more effectively. Cat Product Link is an excellent tool to help fleet managers maximize efficiency and control costs.

Equipped for Versatility

A variety of undercarriage and work tool offerings help customers equip the D6T for optimized performance in a wide range of working conditions.

Serviceability and Customer Support

Cat machines are designed for ease of serviceability so they can spend more productive time on the job site. Cat dealer preventive maintenance and repair expertise, along with machine rebuild capability, help reduce overall owning and operating costs.

Contents

Operator Station.....	3
Structures.....	3
Engine	4
Power Train.....	5
Implement and Steering Controls	6
Integrated Technologies.....	7
Work Tools.....	8
Rear Implements	9
Undercarriage	9
Serviceability.....	10
Total Customer Support	11
Sustainability	11
D6T Specifications.....	12
D6T Standard Equipment.....	17
D6T Optional Equipment.....	18



The Cat® D6T has earned a reputation for best-in-class versatility, productivity and resale value. Because it excels across a wide range of dozing tasks, customers choose the D6T for everything from dozing, ripping, scraper work and land clearing to finish grading, backfilling trenches, building oil/gas/wind farm pads and working landfills. The D6T offers many of the robust features found on larger tractors, with the reliability and low operating costs customers have come to expect from Cat Track-Type Tractors.

Operator Station

Comfort and Convenience



The D6T cab is designed for operator productivity, safety and comfort. An isolation-mounted, pressurized cab reduces noise and vibration. Large single-pane windows offer excellent visibility. The low rear window enables excellent rearward visibility and lets the operator see the ripper tip. The tapered hood, notched fuel tank, and narrow single-shank ripper carriage give the operator a clear line of sight to front and rear work areas.

The Cat Comfort Series seat is well padded and adjustable, with bolsters to help support the operator when working on slopes. Armrests are adjustable without tools, and heating/air conditioning vents evenly distribute airflow. The cab is pre-wired for a radio and equipped with two speakers, an antenna and a radio mount recessed in the headliner. A 10-amp, 12-volt power converter is also included to provide convenient supplemental power for cellular phones and computers.

Structures

Rugged design for maximum service

The foundation of every Cat dozer is a rugged frame built to absorb high impact shock loads and twisting forces. A reinforced saddle, welded front cross-member and steel castings on the main case add to the overall strength.

The pivot shaft is bolted to the mainframe and connects to the rear roller frames to allow independent oscillation. The pivot shaft distributes impact loads through the case. This design eliminates alignment problems and the need for diagonal braces on the roller frames.

The pinned equalizer bar gives the roller frames the ability to oscillate up and down to better match ground contours for maximum traction and operator comfort. Bolted end pins offer longer life and reduce downtime with improved serviceability and reliability. A remote lubrication point in the engine compartment provides easy access to lubricate the center pin of the equalizer bar as part of scheduled maintenance practices.

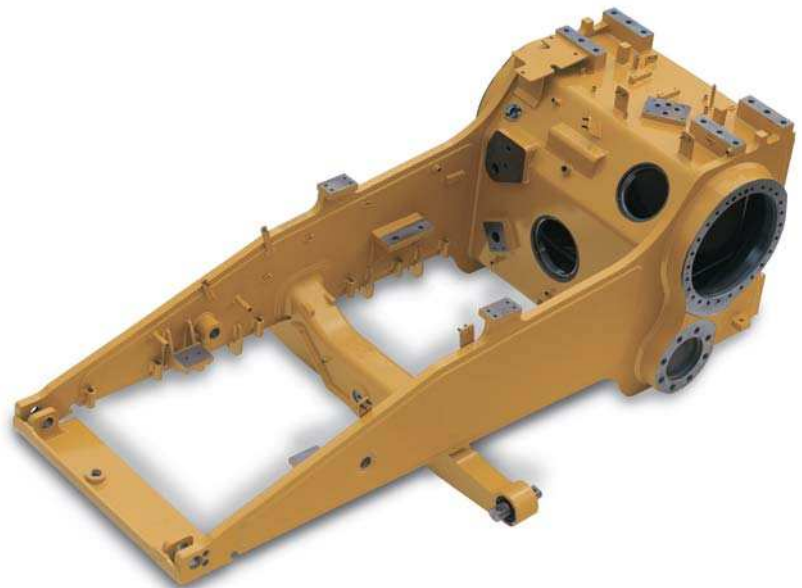

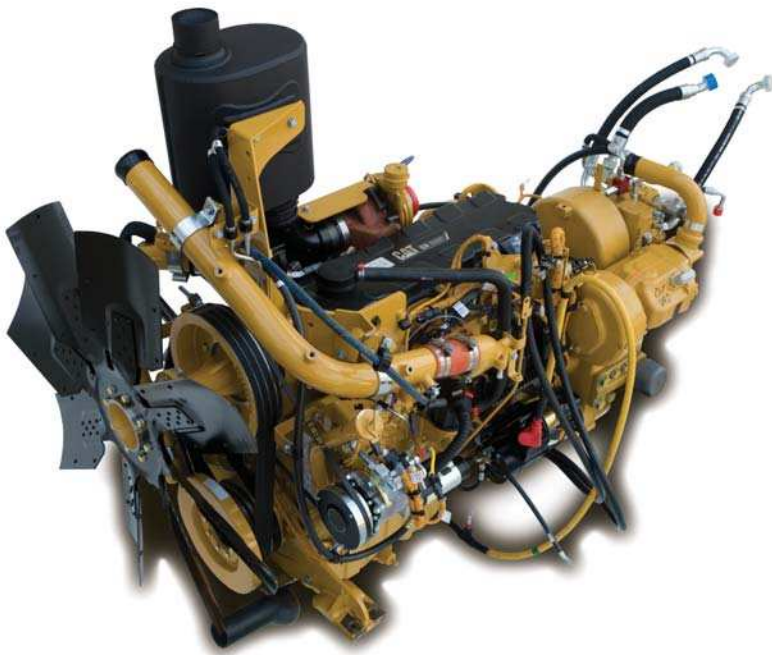

Engine

Power and Sustainability

Every component of a Cat engine is carefully designed to maximize durability and reliability. Precise controls optimize power and fuel efficiency while reducing emissions.

The D6T features a Cat C9 engine with ACERT™ Technology. A series of Caterpillar engineered innovations provide advanced electronic control, precision fuel delivery and refined air management, resulting in outstanding performance and lower emissions.

Modular design and advanced electronic diagnostics enhance the engine's serviceability. An optional sand blast grid equips the machine for high airborne debris applications, and a demand fan saves fuel in low ambient temperature conditions.

Cooling System

The D6T cooling system is durable and efficient, utilizing aluminum bar plate construction on the radiator cores and Air To Air After Cooler (ATAAC). Aluminum bar plate provides durability and allows for high heat transfer and superior corrosion resistance. The radiator consists of twin unit cores that act together as one heat exchanger.

The Air To Air After Cooler is part of an advanced air management system that brings cool air to the engine. This increases life, reduces emissions, and helps maximize fuel efficiency.

The twin core is designed for easy service. Either half of the radiator can be removed by itself to reduce downtime and repair costs. A sight gauge makes daily service checks convenient.

The rugged aluminum bar plate construction helps protect against coolant leaks caused by tube punctures in abrasive applications. The unit core construction also reduces leak potential by eliminating core seals.

Power Train

Powerful efficiency

The powershift transmission and differential steering work in tandem with the Cat C9 engine to deliver outstanding power, productive performance and reliability.

Two Pump Hydraulic System

A dual hydraulic pump design provides dedicated hydraulic power to steering and implements for a 20 percent steering improvement. The slip pump design improves response in simultaneous steering/implement applications for greater maneuverability. The constant flow in steering circuit improves hydraulic cooling, increasing cooling capacity.

Multi Velocity Program (MVP)

This exclusive machine control system allows the operator to choose from five speed ranges in Forward and Reverse to best match machine speed to applications and ground conditions. MVP improves productivity in light applications (partial blade loads), where more speed flexibility is desired.

Differential Steering System

Differential steering maintains full power to both tracks, providing best in class turning with a loaded blade. When one track speeds up, the other slows down an equal amount. Maneuverability – especially with large blade loads – is improved, as well as cycle times in some applications. Greater load capacity, power and speed control are possible in soft underfoot conditions on steep slopes because both tracks are powered during turns. Low effort tiller bar, touch shift control and steering modulation insure ease of operation.

Torque Divider

A single-stage torque divider sends 70 percent of engine torque through a converter and 30 percent through a direct drive shaft. This provides greater drive line efficiency and higher torque multiplication, delivering more power to the ground to optimize operator productivity.

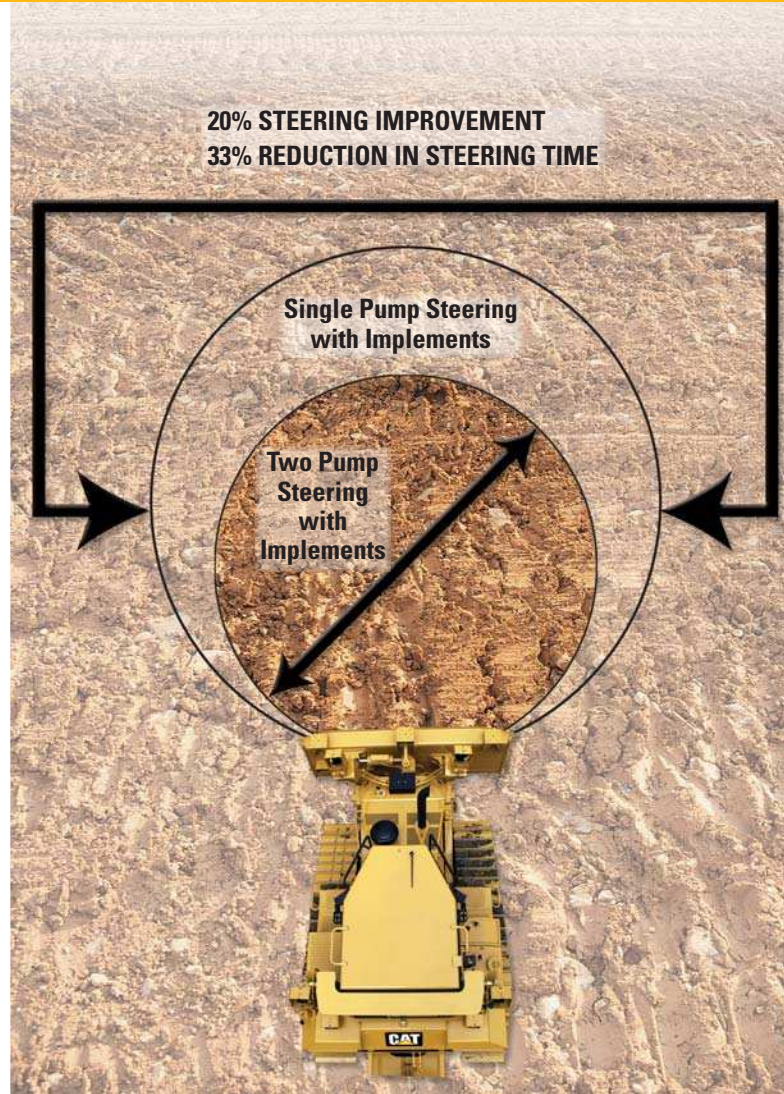

Implement and Steering Controls

Ergonomically designed for ease of operation



Steering and Transmission Control

Turns and directional changes are controlled with a single tiller handle. Buttons change the electronically controlled powershift transmission. Operators are able to work precisely in tight areas and around obstacles.

Dozer and Ripper Control Levers

The D6T features ergonomically designed dozer and ripper controls with low-effort, pilot-operated hydraulics. When equipped with a VPAT blade, the blade control allows simultaneous six-way control of the blade with a thumb rocker. The dozer control is equipped as an electro-hydraulic control when the AccuGrade™ Ready Option is installed.

Throttle Rocker Switch

The fingertip rocker switch activates high or low idle. A decelerator pedal gives the operator full control of engine speed when the rocker switch is in the high idle position. Engine speed can be set between high and low idle by simultaneously using the decelerator pedal and holding the Rabbit side of the throttle switch for three seconds.

Work Tool Lock-Out Switch

Work tool lock-out prevents inadvertent operation of hydraulic work tool attachments.

Auto-Shift/Auto-Kickdown

Operators can pre-select a forward and reverse speed setting for easy, efficient directional changes. Auto-kickdown allows the transmission to automatically downshift when significant load increases are detected.

Instrument Panel and Cat Monitoring System

The instrument panel, with easy-to-read gauges and warning lamps, keeps the operator aware of all system information. All gauges and readouts are easily visible in direct sunlight. The Cat Monitoring System has a dash mounted instrument cluster showing on-the-go operating information and insight into operation and maintenance needs.





Integrated Technologies

Solutions to make work easier and more efficient

AccuGrade System for Track-Type Tractors

The AccuGrade System automates blade control for greater grading accuracy and more cost effective operation. Machine-mounted sensors calculate precise blade slope and elevation, which is used by sensors to automatically adjust the blade to maintain grade. Automated blade control improves efficiency and productivity by reaching grade faster and in fewer passes, reducing the need for traditional survey stakes or grade checkers.

AccuGrade Ready Option

AccuGrade systems and controls can be integrated from the factory, making system installation and setup quick and easy. Integration also provides greater wear protection and reliability.

AccuGrade Laser

Laser signals from a transmitter on the work site are picked up by a machine mounted receiver to provide a constant grade reference. The system calculates blade adjustments to achieve grade, makes automatic elevation adjustments and provides automatic blade control. The system also calculates cut/fill requirements for manual blade control.

AccuGrade GPS

Using global satellite-based positioning, AccuGrade GPS computes 3-dimensional positioning information on the machine, compares the position of the blade relative to the design plan, and delivers that information to the operator via an in-cab display.

Cat Product Link*

Remote monitoring with Product Link improves overall fleet-management effectiveness. Product Link is deeply integrated into machine systems. Events and diagnostic codes, as well as hours, fuel, idle time and other detailed information are transmitted to a secure web based application, VisionLink™. VisionLink includes powerful tools to convey information to users and dealers, including mapping, working and idle time, fuel level and more.

** Product Link licensing not available in all areas. Please consult your Cat dealer for availability.*

Work Tools

Equipped for the job



L-Shaped Push Arms

L-shaped push arms bring the blade closer to the machine than diagonal brace designs, providing excellent maneuverability, balance, and blade penetration. This design provides solid lateral stability and better cylinder positions for constant pryout independent of blade height.

Load Sensing Hydraulics

Field-proven, load-sensing hydraulics respond to operating requirements by automatically and continually adjusting hydraulic power to maximize work tool efficiency.

Cat Blades

Cat blades feature a strong box-section design, made from Cat DH-2™ steel with high tensile strength to stand up to the most severe applications. Heavy moldboard construction and hardened bolt-on cutting edges and end bits add strength and durability.

Semi-Universal Blade

The Semi-Universal blade is built for tough applications where penetration and capacity are important. The blade wings are designed for superior load retention and penetration in tightly packed materials.

Straight Blade

The S-blade provides good versatility. Because it has less blade capacity, it can handle heavier materials than a larger blade.

Angle Blade

The angle blade is secured by outside-mounted push arms using a pinned connection that allows blade angling and tilting, left or right. Blade angle is changed manually and blade tilt is changed hydraulically.

Variable Pitch Angle Tilt (VPAT) Blade

The VPAT blade allows the operator to hydraulically adjust the blade lift, angle, and tilt simultaneously. The operator can also manually adjust blade pitch when the needs arise. This versatility gives the D6T the ability to take on a variety of applications such as finish grading, spreading material, slot-dozing, side casting, V-ditching, and trench backfilling.



Rear Implements

Versatility and balance



Multi-Shank Ripper

The multi-shank parallelogram style ripper is offered with one, two, or three shanks to best suit job conditions. Curved or straight ripper shanks are available.

Winch

A single lever control actuates both clutch and brake functions to help improve operator efficiency. See your Cat dealer for available winch options.

Rear Counterweight

Optimize balance for backing up steep slopes or increasing performance in heavy dozing applications. Rear counterweights are recommended if another rear attachment is not specified, and are required with VPAT blades.

Drawbar

The D6T can be equipped with a drawbar for retrieving other equipment or pulling work tools such as disks, compactors, or chopper wheels. Optional implement towing arrangements allow for quick setup of a hydraulically controlled towed scraper.

Undercarriage

Engineered for performance

The D6T features the Caterpillar elevated sprocket design that isolates final drives, axles, and steering components from harsh impacts. The modular design aids serviceability to help reduce maintenance costs. A variety of undercarriage configurations and track shoe designs help optimize performance and undercarriage life.

SystemOne™ Undercarriage

SystemOne can help reduce total undercarriage owning and operating costs in many applications. Lifetime sealed and lubricated cartridges eliminate bushing turns and sprockets require no replacement during the life of the chain. All SystemOne undercarriage components are designed to work and wear as a system for longer track life.

Heavy Duty Undercarriage (optional)

Heavy duty undercarriage is well-suited to aggressive applications like land clearing, side-slopes, or working in rocky or uneven terrain. Components are designed for extended wear life in abrasive conditions and high impact applications.

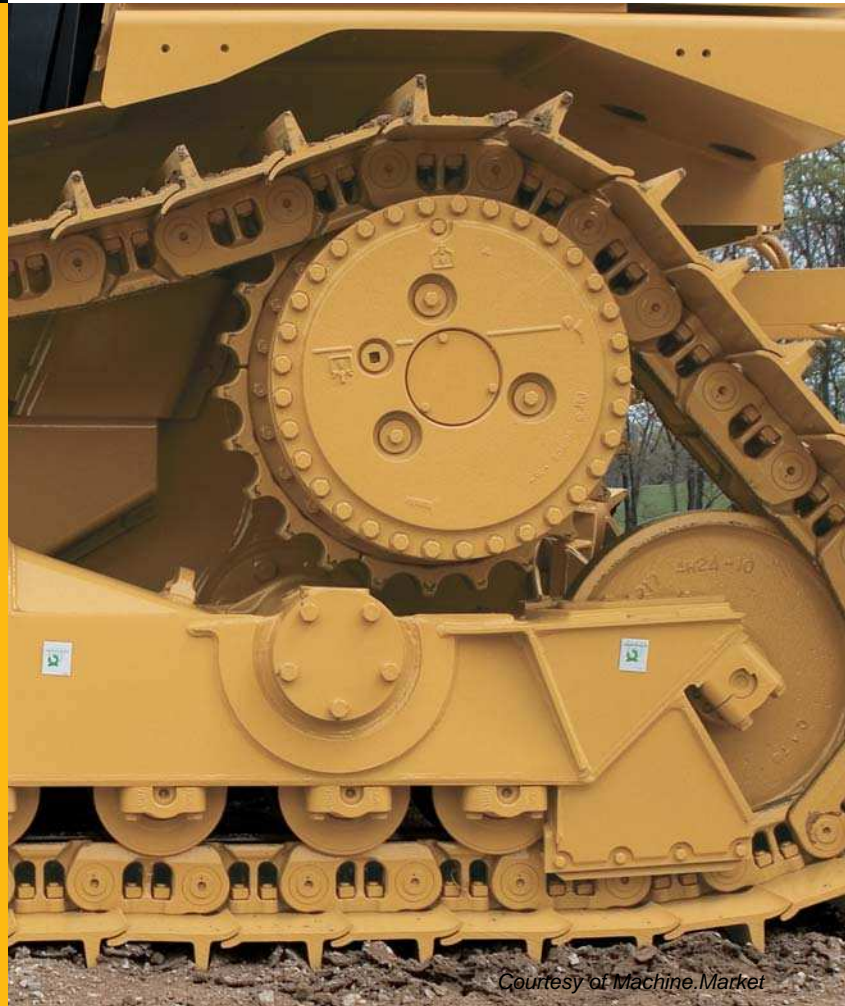

Serviceability

When uptime counts



Cat Track-Type Tractors are designed with ease of serviceability in mind. Modular components, grouped service points and quick diagnostics help keep machines actively at work on the job site.

Power Train Oil Filter and Pressure Taps

The power train oil filter and pressure taps are remote-mounted in the right-hand fender. Quick disconnect fittings allow for fast diagnosis of the power train and hydraulic oil systems.

Engine Oil Filter

The engine oil filter is easily accessed on the right side of the engine compartment. An optional quick oil change attachment can further reduce maintenance time.

Water Separator and Fuel Filter

Easily located just inside the engine access panel, the water separator functions as the primary fuel filter, just ahead of the secondary fuel filter. A standard electric priming pump on the primary filter reduces the effort required to prime the system.

Scheduled Oil Sampling Analysis (S-O-SSM)

Preventive maintenance through Scheduled Oil Sampling is made easier through live sampling ports for the engine oil, power train hydraulics and coolant. The ports are color coded for easy identification of each system.



Total Customer Support

Renowned dealer support

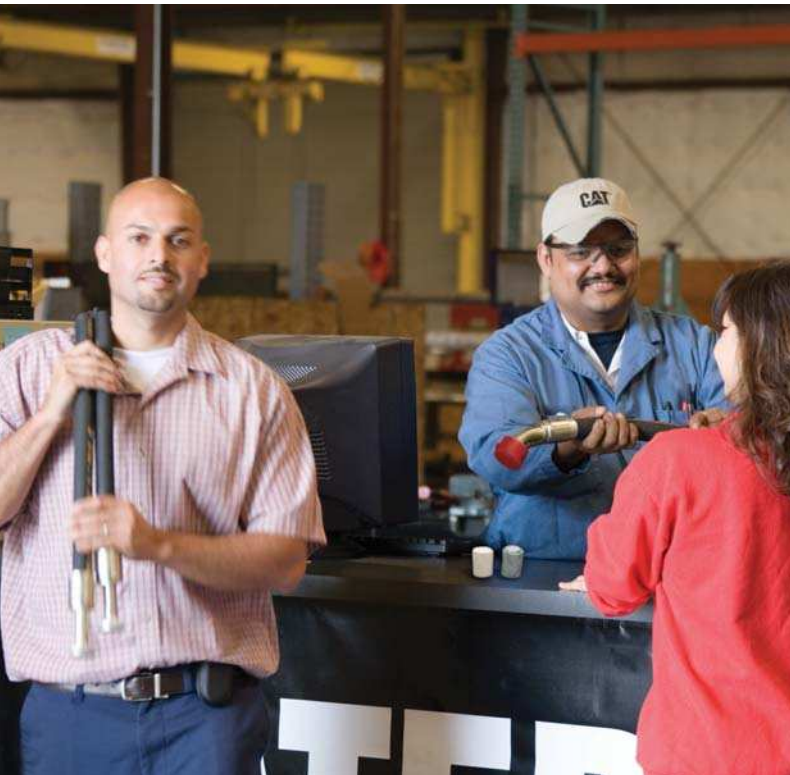

Only Cat machines come with the industry's best sales and service support – the Cat dealer network. From helping you choose the right machine to ongoing support, your Cat dealer provides the best in sales and service. Manage your costs with preventive maintenance programs like Custom Track Service, Scheduled Oil Sampling (S•O•SSM) analysis, and guaranteed maintenance contracts. Stay productive with best-in-class parts availability. Your Cat dealer can even help with operator training to help you boost your profits.

And when it's time for replacement, your Cat dealer can help you save even more with Genuine Cat Remanufactured parts. Remanufactured power train and hydraulic components cost less, but come with the same warranty and reliability as new products. Talk with your Cat dealer to learn more about reducing waste and saving money through Cat Remanufacturing.

Sustainability

Thinking generations ahead

- ACERT™ engine technology helps improve fuel efficiency and reduce emissions.
- Ease of operation, operator comfort and excellent visibility help operators stay focused for enhanced job site safety.
- Technologies like Product Link help improve overall efficiency, safe fuel and fluids, and reduce equipment wear and tear.
- Ecology drains help make draining fluids more convenient and help prevent spills.
- Major components are built to be rebuilt, eliminating waste and saving customers money by giving the machine and/or major components a second – and even third – life.



D6T Specifications

Engine – STD

Engine Model	Cat® C9 ACERT™	
Engine Power		
SAE J1995	159 kW	213 hp
ISO 14396	152 kW	204 hp
ISO 14396 Metric	207 hp	
Net Power		
SAE J1349	138 kW	185 hp
ISO 9249	138 kW	185 hp
ISO 9249 Metric	188 hp	
80/1269/EEC	138 kW	185 hp
Bore	112 mm	4.4 in
Stroke	149 mm	5.9 in
Displacement	8.8 L	537 in ³

Engine – XL/LGP

Engine Model	Cat® C9 ACERT™	
Engine Power		
SAE J1995	170 kW	228 hp
ISO 14396	163 kW	219 hp
ISO 14396 Metric	222 hp	
Net Power		
SAE J1349	149 kW	200 hp
ISO 9249	149 kW	200 hp
ISO 9249 Metric	203 hp	
80/1269/EEC	149 kW	200 hp
Bore	112 mm	4.4 in
Stroke	149 mm	5.9 in
Displacement	8.8 L	537 in ³

- Engine ratings apply at 1,850 rpm.
- Net power advertised is the power available at the engine flywheel when the engine is equipped with a fan at maximum speed, air cleaner, muffler and alternator.
- No deratings required up to 2286 m (7,500 ft) altitude, beyond 2286 m (7,500 ft) automatic derating occurs.

Transmission

	5 Speed	3 Speed		
1.5 Forward	1	3.8 km/h	2.33 mph	
2.0 Forward		5.2 km/h	3.2 mph	
2.5 Forward	2	6.6 km/h	4.09 mph	
3.0 Forward		8.5 km/h	5.3 mph	
3.5 Forward	3	11.4 km/h	7.11 mph	
1.5 Reverse	1	4.8 km/h	3 mph	
2.0 Reverse		6.6 km/h	4.1 mph	
2.5 Reverse	2	8.4 km/h	5.22 mph	
3.0 Reverse		10.9 km/h	6.8 mph	
3.5 Reverse	3	14.6 km/h	9.04 mph	

Service Refill Capacities

Fuel Tank	424 L	112 gal
Cooling System	76.8 L	20.3 gal
Engine Crankcase	28 L	7.4 gal
Power Train	145.7 L	38.5 gal
Final Drives (each)	13.6 L	3.6 gal
Roller Frames (each)	24.6 L	6.5 gal
Pivot Shaft	5 L	1.3 gal
Compartment		
Hydraulic Tank	51.5 L	13.6 gal

Weights

Operating Weight		
STD A-Blade	19 969 kg	44,024 lb
STD SU-Blade	19 429 kg	42,834 lb
XL A-Blade	20 661 kg	45,550 lb
XL SU-Blade	20 449 kg	45,082 lb
XL VPAT-Blade	23 152 kg	51,041 lb
XW A-Blade	21 580 kg	47,576 lb
XW SU-Blade	21 301 kg	46,961 lb
XW VPAT-Blade	23 601 kg	52,031 lb
LGP S-Blade	22 039 kg	48,588 lb
LGP A-Blade	23 074 kg	50,869 lb
LGP VPAT-Blade	24 121 kg	53,178 lb

Shipping Weight

STD A-Blade	16 266 kg	35,860 lb
STD SU-Blade	16 266 kg	35,860 lb
XL A-Blade	17 050 kg	37,589 lb
XL SU-Blade	17 050 kg	37,589 lb
XL VPAT-Blade	17 629 kg	38,865 lb
XW A-Blade	17 769 kg	39,174 lb
XW SU-Blade	17 769 kg	39,174 lb
XW VPAT-Blade	17 958 kg	39,591 lb
LGP S-Blade	18 811 kg	41,471 lb
LGP A-Blade	18 811 kg	41,471 lb
LGP VPAT-Blade	18 499 kg	40,783 lb

- Operating Weight includes blade, lubricants, coolant, full fuel tank, standard track, ROPS/FOPS cab, drawbar and operator.
- Shipping Weight includes lubricants, coolant, ROPS/FOPS cab, standard track and 10% fuel.

Hydraulic Controls – Pump

RPM at rated Engine Speed – Implement	1,965 rpm	
RPM at rated Engine Speed – Steering	2,625 rpm	
Pump Output – Implement	189 L/min	49.9 gal/min
Pump Output – Steering	179 L/min	47.3 gal/min
Lift Cylinder Flow	189 L/min	49.9 gal/min
Tilt Cylinder Flow	80 L/min	21.1 gal/min
Ripper Cylinder Flow	189 L/min	49.9 gal/min
Angle Cylinder Flow – VPAT	170 L/min	44.9 gal/min

Hydraulic Controls – Main Relief Valve

Pressure Setting – Steering	41 700 kPa	6,048 psi
Pressure Setting – Implement (Non-VPAT)	21 700 kPa	3,147 psi
Pressure Setting – Implement (VPAT)	24 440 kPa	3,545 psi

Hydraulic Controls – Maximum Operating Pressure (Non-VPAT)

Bulldozer – Lift	19 300 kPa	2,799 psi
Bulldozer – Tilt	19 300 kPa	2,799 psi
Ripper	19 300 kPa	2,799 psi

Hydraulic Controls – Maximum Operating Pressure (VPAT)

Bulldozer – Lift	21 550 kPa	3,126 psi
Bulldozer – Tilt	21 550 kPa	3,126 psi
Bulldozer – Angle	21 550 kPa	3,126 psi
Ripper	19 300 kPa	2,799 psi

Ripper

Type	Fixed Parallelogram	
Number of Pockets	3	
Overall Beam Width	2202 mm	87 in
Beam Cross Section	216 × 254 mm	8.5 × 10 in
Maximum Clearance Raised (under tip, pinned in bottom hole)	511 mm	20.1 in
Maximum Penetration	500 mm	19.7 in
Maximum Penetration Force	6603 kg	14,557 lb
Pryout Force	9134 kg	20,137 lb
Weight – With One Shank	1634 kg	3,606 lb
Each Additional Shank	74 kg	163 lb

Winch

Winch Model	PA56	
Maximum bare drum line pull*	40 750 kg	89,800 lb
Rated bare drum line pull	26 800 kg	59,100 lb
Winch Model	PA56 Optional Gearing	
Maximum bare drum line pull	40 750 kg	89,800 lb
Rated bare drum line pull	31 750 kg	70,000 lb
Maximum recommended drum capacity		
Recommended rope (22 mm/ 0.88 in)	55 m	180 ft
Optional rope (25 mm/1.0 in)	50 m	163 ft
Weight	1180 kg	2,600 lb
Oil Refill Capacity	67 L	17.8 gal
Drum diameter	255 mm	10 in
Increased tractor length	517 mm	20.4 in
Increased tractor length LGP	397 mm	15.6 in

* Maximum line pull is lesser of actual line pull at maximum PTO output torque or catalog breaking strength of maximum optional size new IWRC IPS wire rope.

Standards

ROPS/FOPS	ROPS meets criteria SAE J395, SAE 1040 MAY 94, ISO 3471-1994/ FOPS meets ISO 3449-1992 Level II
Cab	Meets appropriate standards as listed below.
Brakes	Brakes meet criterion SAE J/ISO 10265 MAR99

- The operator sound exposure Leq (equivalent sound pressure level) measured according to the work cycle procedures specified in ANSI/SAE J1166 OCT 98 is 80 dB(A) for cab offered by Caterpillar when properly installed and maintained and tested with the doors and windows closed.
- Hearing protection may be needed when operating with an open operator station and cab (when not properly maintained or doors/windows open) for extended periods or in noisy environment.
- The exterior sound pressure level for the standard machine measured at a distance of 15 m (49.2 ft) according to test procedures specified in SAE J88 APR 95, mid-gear-moving operation, is 85 dB(A).

D6T Specifications

Dimensions

All dimensions are approximate.

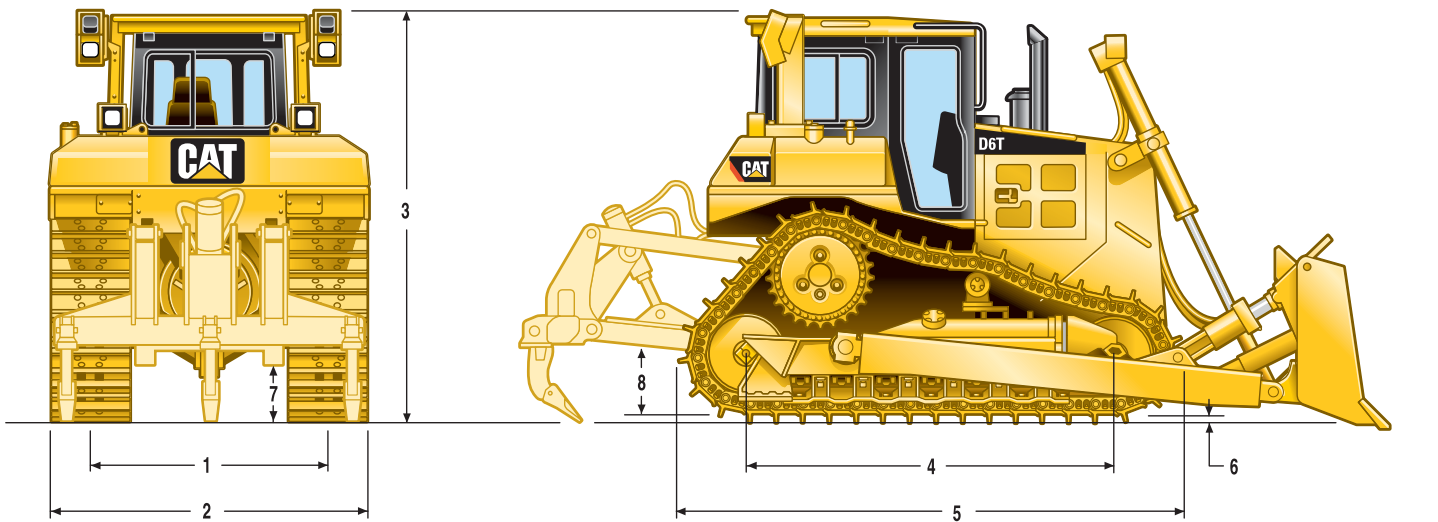

	STD		XL		XL VPAT	
1 Track gauge	1880 mm	74 in	1880 mm	74 in	2134 mm	84 in
2 Width of tractor						
Over trunnions	2640 mm	8 ft 8 in	2640 mm	8 ft 8 in	—	—
Without trunnions (std. track)	2440 mm	8 ft 0 in	2440 mm	8 ft 0 in	2692 mm	8 ft 10 in
3 Machine height from tip of grouser:						
Stack	3143 mm	10 ft 4 in	3143 mm	10 ft 4 in	3143 mm	10 ft 4 in
ROPS	3195 mm	10 ft 6 in	3195 mm	10 ft 6 in	3195 mm	10 ft 6 in
4 Length of track on ground	2664 mm	8 ft 9 in	2871 mm	9 ft 5 in	2871 mm	9 ft 5 in
5 Length of basic tractor	3658 mm	12 ft 0 in	3860 mm	12 ft 8 in	3860 mm	12 ft 8 in
With following attachments add:						
Drawbar	217 mm	8.5 in	217 mm	8.5 in	217 mm	8.5 in
Ripper Multi-Shank (tip at ground line)	1403 mm	4 ft 7 in	1403 mm	4 ft 7 in	1403 mm	4 ft 7 in
Winch	517 mm	1 ft 8 in	517 mm	1 ft 8 in	517 mm	1 ft 8 in
S Blade	1043 mm	3 ft 5 in	—	—	—	—
SU Blade	1235 mm	4 ft 1 in	1472 mm	4 ft 10 in	—	—
A Blade	1147 mm	3 ft 9 in	1349 mm	4 ft 5 in	—	—
VPAT Blade	—	—	—	—	1524 mm	5 ft 0 in
6 Height of grouser	65 mm	2.6 in	65 mm	2.6 in	65 mm	2.6 in
7 Ground clearance	383 mm	1 ft 3 in	383 mm	1 ft 3 in	383 mm	1 ft 3 in
Track pitch	203 mm	8.0 in	203 mm	8.0 in	203 mm	8.0 in
Number of shoes per side		39		41		41
Number of rollers per side		6		7		7
Standard shoe	560 mm	22 in	560 mm	22 in	560 mm	22 in
Ground contact area (std. track)	2.98 m ²	4,620 in ²	3.22 m ²	4,972 in ²	3.22 m ²	4,972 in ²
Ground pressure*	0.614 kg/cm ²	8.74 psi	0.623 kg/cm ²	8.90 psi	0.658 kg/cm ²	9.36 psi
8 Drawbar height						
From ground face of shoe	576 mm	1 ft 11 in	576 mm	1 ft 11 in	576 mm	1 ft 11 in
	511 mm	1 ft 8 in	511 mm	1 ft 8 in	511 mm	1 ft 8 in

* STD, XL, XW with SU blade, with no rear attachments unless otherwise specified.

Dimensions

All dimensions are approximate.

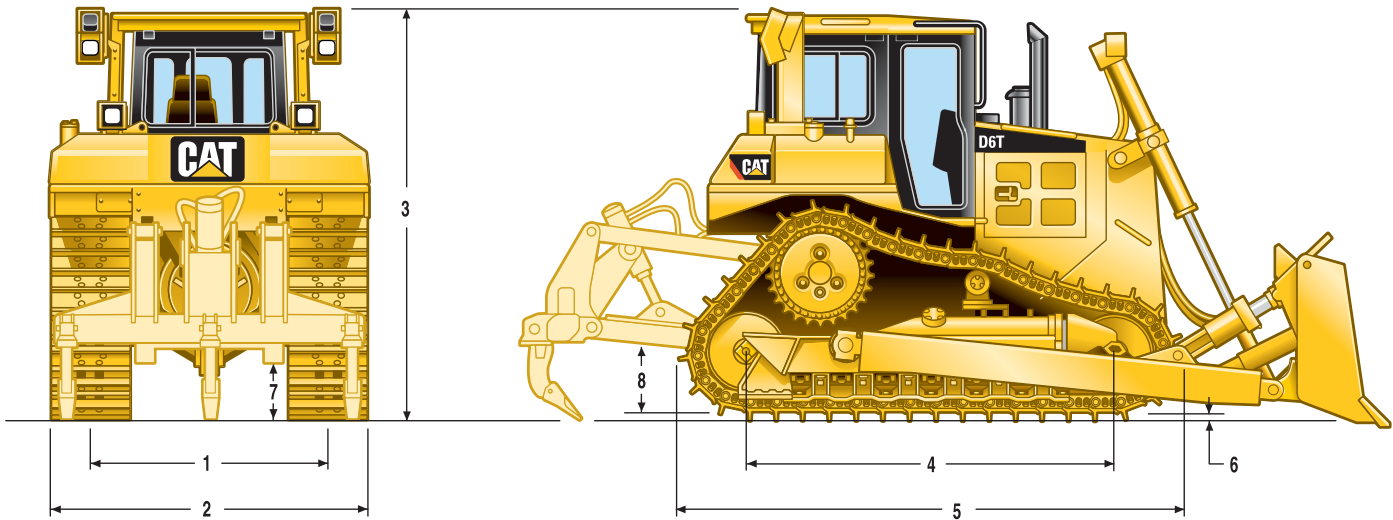

	XW		XW VPAT		LGP S		LGP VPAT	
1 Track gauge	2032 mm	80 in	2286 mm	90 in	2286 mm	90 in	2286 mm	90 in
2 Width of tractor								
Over trunnions	2950 mm	9 ft 8 in	—	—	3480 mm	11 ft 5 in	—	—
Without trunnions (std. track)	2794 mm	9 ft 2 in	2997 mm	9 ft 10 in	3193 mm	10 ft 6 in	3150 mm	10 ft 4 in
3 Machine height from tip of grouser:								
Stack	3143 mm	10 ft 4 in	3143 mm	10 ft 4 in	3193 mm	10 ft 6 in	3193 mm	10 ft 6 in
ROPS	3195 mm	10 ft 6 in	3195 mm	10 ft 6 in	3245 mm	10 ft 8 in	3245 mm	10 ft 8 in
4 Length of track on ground	2871 mm	9 ft 5 in	2871 mm	9 ft 5 in	3275 mm	10 ft 9 in	3275 mm	10 ft 9 in
5 Length of basic tractor	3860 mm	12 ft 8 in	3860 mm	12 ft 8 in	4247 mm	13 ft 11 in	4247 mm	13 ft 11 in
With following attachments add:								
Drawbar	217 mm	8.5 in	217 mm	8.5 in	251 mm	9.9 in	251 mm	9.9 in
Ripper Multi-Shank (tip at ground line)	1403 mm	4 ft 7 in	1403 mm	4 ft 7 in	—	—	—	—
Winch	517 mm	1 ft 8 in	517 mm	1 ft 8 in	397 mm	1 ft 4 in	397 mm	1 ft 4 in
S Blade	—	—	—	—	1218 mm	4 ft 0 in	—	—
SU Blade	1472 mm	4 ft 10 in	—	—	—	—	—	—
A Blade	1349 mm	4 ft 5 in	—	—	—	—	—	—
VPAT Blade	—	—	1524 mm	5 ft 0 in	—	—	1743 mm	5 ft 9 in
6 Height of grouser	65 mm	2.6 in	65 mm	2.6 in	65 mm	2.6 in	65 mm	2.6 in
7 Ground clearance	383 mm	1 ft 3 in	383 mm	1 ft 3 in	433 mm	1 ft 5 in	433 mm	1 ft 5 in
Track pitch	203 mm	8.0 in	203 mm	8.0 in	203 mm	8.0 in	203 mm	8.0 in
Number of shoes per side	41		41		45		45	
Number of rollers per side	7		7		8		8	
Standard shoe	760 mm	30 in	710 mm	28 in	915 mm	36 in	785 mm	31 in
Ground contact area (std. track)	4.36 m ²	6,780 in ²	4.08 m ²	6,328 in ²	5.99 m ²	9,288 in ²	5.16 m ²	7,998 in ²
Ground pressure*	0.472 kg/cm ²	6.72 psi	0.524 kg/cm ²	7.45 psi	0.362 kg/cm ²	5.15 psi	0.446 kg/cm ²	6.35 psi
8 Drawbar height	576 mm	1 ft 11 in	576 mm	1 ft 11 in	626 mm	2 ft 1 in	626 mm	2 ft 1 in
From ground face of shoe	511 mm	1 ft 8 in	511 mm	1 ft 8 in	561 mm	1 ft 10 in	561 mm	1 ft 10 in

* STD, XL, XW with SU blade, with no rear attachments unless otherwise specified.

D6T Specifications

Weight

All dimensions are approximate.

Bulldozer Specifications

		S STD	S LGP	SU STD	SU XL	SU XW	A † STD	A † LGP	A † XL	A † XW	VPAT XL	VPAT XW	VPAT LGP
Blade Capacity	m ³	3.89	3.75	5.61	5.31	5.05	3.93	5.22	3.93	4.30	4.73	5.10	4.32
	yd ³	5.09	4.90	7.34	6.94	6.60	5.14	6.82	5.14	5.63	6.19	6.67	5.65
Width	mm	3360	4063	3260	3260	3556	4166	5070	4500	4200	3880	4160	4160
	ft	11.00	13.33	10.66	10.66	11.66	13.66	16.63	14.75	13.75	12.73	13.65	13.65
Height	mm	1257	1101	1412	1412	1412	1155	1134	1155	1169	1295	1295	1191
	in	50	44	56	56	56	45	45	45	46	51	51	47
Digging Depth	mm	473	655	473	459	459	506	828	524	500	737	737	672
	in	19	26	19	18	18	20	33	21	20	29	29	26
Ground Clearance	mm	1104	1083	1104	1195	1195	1142	1088	1205	1242	1174	1174	1230
	in	44	43	44	47	47	45	43	47	49	46	46	48
Max. Tilt	mm	765	701	743	743	743	408	476	408	408	440	460	502
	in	30	28	29	29	29	16	19	16	16	17	18	20
Weight*	kg	2599	2836	2699	2973	2949	3050	3430	3150	3400	3560	3650	3620
	lb	5,730	6,252	5,950	6,554	6,501	6,724	7,562	6,945	7,496	7,848	8,047	7,981
Weight**	kg	—	—	—	—	—	—	—	—	—	1593	1681	1591
	lb	—	—	—	—	—	—	—	—	—	3,512	3,705	3,507

* Includes push arms, blade, blade tilt cylinder(s), cutting edges and miscellaneous hardware components

** VPAT blade only

† Angle dozers include two tilt cylinders.

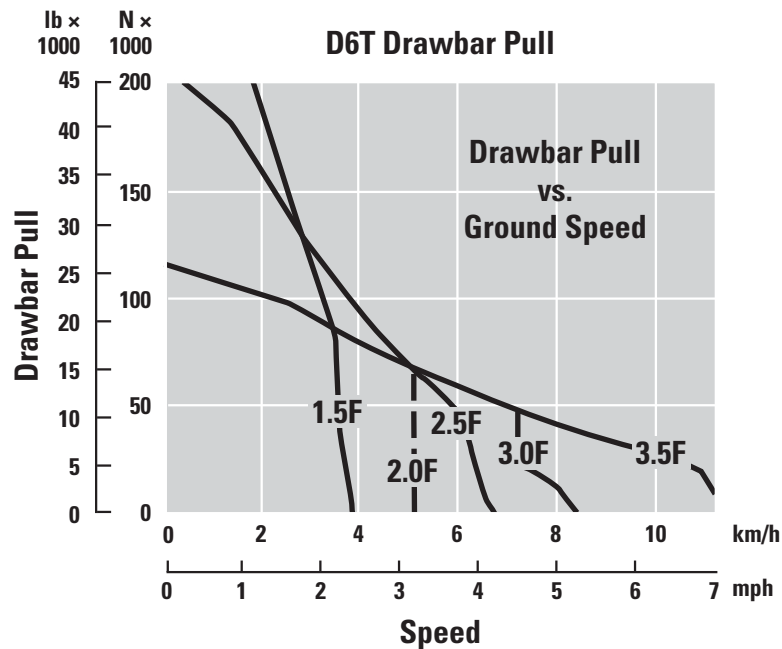

Standard equipment may vary. Consult your Cat dealer for details.

POWER TRAIN

- C9 ACERT diesel engine
- Radiator, Aluminum Bar Plate
- Air cleaner, precleaner
 - with stratta tube dust ejector
- Air filter with electronic service indicator
- Aftercooler, air to air (ATAAC)
- Coolant, extended life
- Fan, blower, direct drive
- Final drives, three planet single reduction planetary
- Fuel priming pump, electric
- Muffler, insulated with mitered stack
- Parking brake, electronic
- Prescreener
- Shift management
 - Automatic directional and downshift
 - Controlled throttle, load compensated
- Starting aid, ether, automatic
- Torque divider
- Transmission, electronically controlled powershift 3F/3R speeds
- Turbocharger, wastegate
- Water separator

UNDERCARRIAGE

- SystemOne
- Carrier rollers
- Equalizer bar, heavy duty
- Guards, end track guiding
- Idlers, center tread, lifetime lubricated
- Rollers, lifetime lubricated track
- Track roller frames, tubular
- Track adjusters, hydraulic
- Sprocket rim segments, replaceable

ELECTRICAL

- Alarm, backup
- Alternator, 95 amp, brushless
- Batteries, 2 maintenance free 12V (24V system), heavy duty
- Converter, 12V, 10 amp with 2 outlets
- Connector, diagnostic
- Electric start, 24V
- Horn, forward warning

OPERATOR ENVIRONMENT

- Air conditioner, underhood
- Armrest, adjustable
- Cab, ROPS/FOPS, sound suppressed
- Decelerator pedal
- Differential steering control
 - with touch shift
- Electronic Monitoring System with coolant power train oil, and hydraulic oil temperature, fuel gauge, tachometer, odometer, gear indicator and diagnostic functions
- Foot pads, dash
- Heater
- Hour meter, electronic
- Hydraulic controls, pilot operated
 - with electronic deactivation switch
- Mirror, rearview
- Radio ready
- Seat, adjustable contour suspension
- Seatbelt, retractable 76 mm (3 in)
- Throttle switch, electronic
- Wipers, intermittent

OTHER STANDARD EQUIPMENT

- CD ROM Parts Book
- Engine enclosures, perforated
- Front pull device
- Guards, hinged bottom
- Hood, perforated
- Hydraulics, independent steering and work tool pumps
- Hydraulics, load sensing, dozer lift and tilt
- Oil cooler, hydraulic
- Product link ready
- Radiator doors, louvered, hinged, fan blast deflector
- S·O·SSM sampling ports
- Tool box
- Vandalism protection for fluid compartments and battery box

MANDATORY ATTACHMENTS

BULLDOZER

- 6SU, Basic
- 6SU XL, Basic
- Blade, Landfill, 6SU XL

D6T Optional Equipment

Optional equipment may vary. Consult your Cat dealer for details.

Premium Cab Package with cloth air suspension seat and 20 amp converter
Rear counterweight and drawbar
Heavy Duty Guard Package
Efficiency Package with power train oil change system and fast fill fuel system
Waste Handling Arrangement

POWER TRAIN

Drains, ecology, power train
Prescreener
Grid, radiator core protector
Fan, demand
Fan, ejector
Fan, Flexxaire
Fan, reversible
Precleaner, turbine with screen
Precleaner, turbine without screen
Thermal shield arrangement

UNDERCARRIAGE

Undercarriage, Heavy Duty
Track pairs
(Standard roller frame, 39 section)
Extreme Service (HD)
560 mm (22 in)
Extreme Service (SystemOne)
560 mm (22 in)
Non-Trapezoidal (SystemOne)
610 mm (24 in)
Moderate Service (HD)
560 mm (22 in)
Moderate Service (SystemOne)
610 mm (24 in)
Track pairs
(XL non-VPAT roller frame, 41 section)
Extreme Service (HD)
560 mm (22 in)
Extreme Service (HD)
610 mm (24 in), non-trapezoidal
Extreme Service (SystemOne)
560 mm (22 in)
Extreme Service (SystemOne)
610 mm (24 in), non-trapezoidal
Moderate Service (HD)
610 mm (24 in)
Extreme Service (HD)
610 mm (24 in), trapezoidal
Extreme Service (SystemOne)
560 mm (22 in), center hole

HYDRAULICS

Hydraulics, ripper

STARTERS, BATTERIES AND ALTERNATORS

Alternator, 150 amp
Alternator, 95 amp, ducted
Heater, engine coolant, 120V
Batteries, heavy duty and starter

ELECTRICAL

Lights, five
Lights, seven
Lights, eleven
Lights, sweeps
Light, warning strobe
Switch, disconnect, remote mounted

OPERATOR ENVIRONMENT

Air conditioner, ROPS mounted
Canopy
Seat, vinyl
Camera, rear vision
Cab, arrangement with screens
Glass, dual pane and precleaner
Handles, heavy duty

TECHNOLOGY PRODUCTS

Security system, machine
AccuGrade ready, cab
Blade groups with AccuGrade mounts

GUARDS

Note: Additional guarding may be required for some tractor applications

Guards
Idler seals
Crankcase, heavy duty
Radiator, hinged
Metal hose protection sleeve
Final drive, clamshell
Final drive seals
Fuel tank
Precleaner
Radiator, HD
Radiator, hinged, HD
Rear tractor
Screen, rear
Forestry
Track, moderate service
Track, full length
Track, full
Striker bars
Front
Rear
Striker bar box, rear

COUNTERWEIGHTS AND DRAWBARS

Counterweight, additional
Counterweight, rear slab
Counterweight, rigid short

WINCH

Please see your Cat dealer for Winch options

MISCELLANEOUS

Paint, black hood and cylinders
Sweeps

BLADES

6SU
6S
6A
Blade, Landfill, 6SU

GROUND ENGAGING TOOLS

Ripper, multi-shank
Tooth, multi-shank ripper
Tooth, straight (1, 2 or 3)

D6T Track-Type Tractor

For more complete information on Cat products, dealer services, and industry solutions, visit us on the web at www.cat.com

© 2012 Caterpillar Inc.
All rights reserved

Materials and specifications are subject to change without notice. Featured machines in photos may include additional equipment. See your Cat dealer for available options.

CAT, CATERPILLAR, SAFETY.CAT.COM, their respective logos, "Caterpillar Yellow" and the "Power Edge" trade dress, as well as corporate and product identity used herein, are trademarks of Caterpillar and may not be used without permission.

AEHQ6742 (04-2012)
Replaces AEHQ5761-04

