

D9R

Track-Type Tractor



Engine

Engine Model	Cat® 3408C	
Flywheel Power	302 kW	405 hp
Gross Power	330 kW	443 hp

Weights

Operating Weight	48 784 kg	107,550 lb
Shipping Weight	36 154 kg	79,705 lb

Courtesy of Machine.Market

Features

Engine

The rugged, easy to service 3408C engine features high torque rise for superior lugging and productivity.

Transmission

The modular, easy to service transmission features excellent torque transfer to the final drives, maximizing tractor efficiency and productivity.

Operator Station

The D9R operator station is designed for comfort and ease of operation.

Serviceability and Customer Support

Combine easy access, modular components with the Cat dealer repair and rebuild capability ensures rapid machine repair and minimum downtime.



Contents

Engine	3
Advanced Modular Cooling System	4
Transmission	5
Torque Divider	6
Operator Station	7
Structure	8
Undercarriage	9
Work Tools	10
Serviceability	11
Customer Support	12
D9R Track-Type Tractor Specifications	13
D9R Standard Equipment	16
D9R Optional Equipment	17
Notes	18

Engineered for demanding work.

The D9R's durable construction is made for tough working conditions. It keeps material moving with the reliability and low operating costs you expect from Cat® tractors.

Engine

Delivers excellent reliability and durability for years of service.

3408C DITA Engine

The 3408C engine is a field proven engine that delivers excellent reliability and durability in all applications.

High Torque Rise

The 18 liter engine delivers a high torque rise, providing excellent lugging capacity to move heavier loads more efficiently.

Simplicity

The mechanically controlled engine provides ease of diagnostics in remote areas where diagnostic tools may not be available.

Durability

Designed to be rebuilt over and over. Tolerant of many different levels of fuel and oil quality.

High Tensile Strength Block

The 3408C block is cast from high-tensile-strength gray iron. The one piece casting is stabilized to maintain internal dimensions under all operating conditions.

Four Valve Cylinder Heads

The engine uses two intake and two exhaust valves with hardened valve faces that are designed to be reground. Rotators turn the valves about three degrees each lift to distribute wear and maintain heat transfer. Valve stems are made from hardened, chrome plated steel to provide excellent wear and heat resistance.

Cooling

An internal top-deck cooling shelf increases coolant flow to the top of the cylinders for long cylinder liner and piston life. The deep-skirted lower structure and heavy internal ribbing add strength and rigidity to the block.

Carbon Steel Forged Crankshaft

The crankshaft is a carbon steel forging, fully heat-treated, super-finished and dynamically balanced.

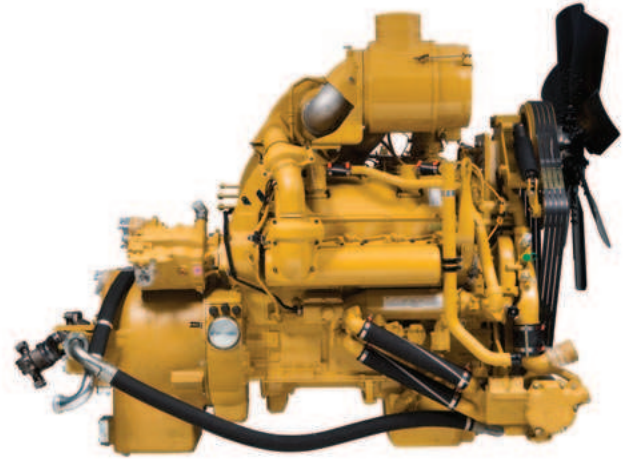

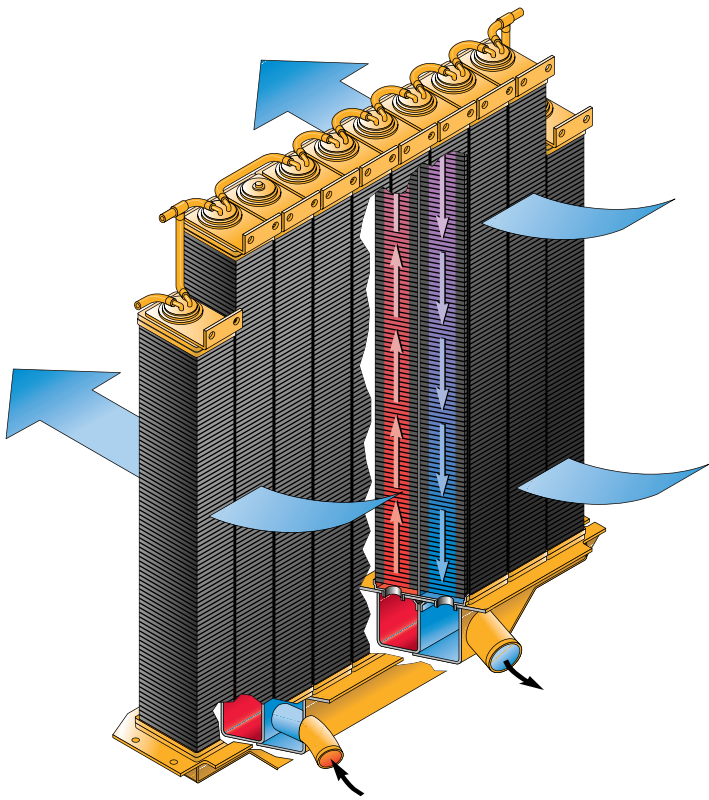

Advanced Modular Cooling System

Superior cooling in the most demanding work conditions.

Two Pass Cooling System

Circulates coolant from the sectioned bottom tank up through one side of the cooling element and down through the other side returning it to the bottom tank.

Modular Design

The cooling elements are individual core modules that are connected to a sectioned bottom tank. There is no top tank to remove.

- With standard 9 steel fins per inch, a lower fin density reduces plugging.
- Brass tube construction within each core for improved reliability.
- Optional core configurations are available for high ambient and/or high wear applications.

Easy Serviceability

Service of the AMOCS can be performed without tilting the radiator guard. Each core module can be replaced individually (without removing the entire radiator), saving considerable cost and repair time.

Protection From Leaks

To reduce the potential for coolant leaks, brass tubes are welded to a large, thick header, improving strength of the tube-to-header joint. In conditions where abrasive materials can be airborne, the attachment sand blast grid should be used to prevent core damage.

Transmission

Delivers the performance you expect from a Cat[®] machine.

Transmission

The proven Cat planetary power shift transmission operates with three speeds forward and three speeds reverse. With this design, many gears share the load as it gets transferred to the axles. In contrast, with a countershaft transmission, just one gear carries the load.

Single Lever Control

One lever controls both machine speed and direction, easing operator fatigue in demanding applications.

Bevel Gear Design

Helical and spiral bevel transfer gears reduce operator and spectator sound levels by design as well as location, being placed within the rear case of the machine.

Oil Cooled Clutch Packs

The transmission features large oil-cooled clutch packs that efficiently absorb the energy of directional shifts for smooth machine performance and excellent operator comfort. Proprietary F37 clutch material extends clutch life, especially in applications where extensive maneuvering is used to maintain peak machine productivity. This material also minimizes transmission oil contamination compared to materials used in other manufacturers' transmissions.

Separate Transmission Oil Reservoir

The transmission oil sump is separate from both final drive reservoirs, controlling cross contamination in the event of a failure of either system. This allows the use of modular components to maximize uptime over the life of the tractor.

Clutch/Brake Steering

With clutch/brake steering, hand levers combine steering clutch disengagement and braking for each track.

Serviceability

In terms of serviceability, the planetary transmission provides significant advantages. The modular design simplifies removal and installation. Since the bevel gears and pinions are manufactured to such a high degree of accuracy, they do not need to be lapped and mated into sets, reducing repair costs.



Torque Divider

Provides optimum operator efficiency and driveline reliability.

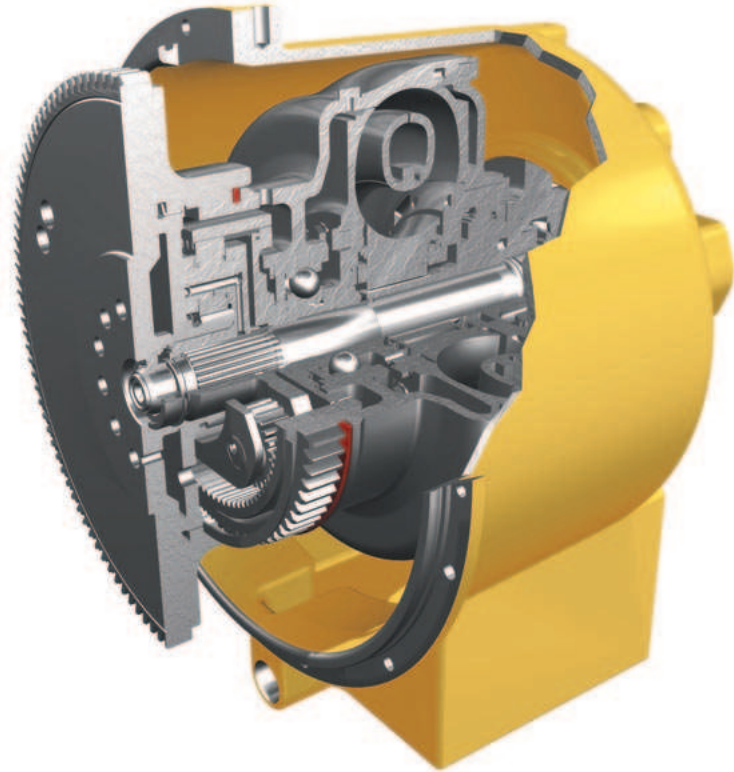

Torque Divider Performance

An improved single-stage torque converter sends 75% of engine torque through a converter and 25% through a direct drive shaft for greater driveline efficiency and higher torque multiplication. The torque divider provides improved efficiency and a broader range of performance in second gear dozing and scraper push loading.

Operating Efficiency and Driveline Reliability

The torque divider shields the driveline from sudden torque shocks and vibration.

Freewheel Stator

Improves torque divider efficiency. During machine operation under low drawbar loads, the stator is permitted to rotate to achieve peak efficiency. The result is a reduction in heat and an increase in fuel efficiency.

Key Benefits of Torque Dividers

- High reliability.
- Proven component design.
- Low dynamic torque.
- Optimum combination of operator efficiency and driveline reliability.
- Components are designed to absorb full engine power.
- High torque multiplication to get heavy loads moving.

Additional Feedback

A minor, but important, by-product of the torque divider is its tendency to increase engine lug all the way to converter stall. This gives the operator additional feedback concerning tractor speed and drawbar pull.



Operator Station

Designed for comfort and ease of operation.

Monitoring System

Provides the operator instant feedback on the condition of operating systems and records performance data to help diagnose problems. Gauges monitor the temperature of the engine coolant, hydraulic oil, power train oil, and fuel level. Includes alert indicators that monitor engine oil pressure, coolant flow, electrical system and transmission oil filter.

Comfortable Operation

An optional isolation-mounted cab reduces noise and vibration. The Cat Comfort Series Seat is fully adjustable and designed for comfort and support. The seat and back cushions are thicker to reduce pressure on the lower back and thighs while allowing unrestricted arm and leg movement.

Clear Full-Circle View

A tapered hood and “notched” fuel tank give the operator a clear line of sight to the front and rear work areas. The low rear window lets the operator see the ripper tip. The large single-pane door windows allow clear sight to each side without leaning.

Interior Storage and Amenities

Includes intermittent windshield wipers, 12-volt power outlet, first aid kit storage, inside door releases, lunch box tie-downs, cup holder, console pads, standard 24 to 12 volt converter, speakers and antenna.

Isolation-Mounted Operators Platform

The D9R features an isolation-mounted operators platform with standard ROPS/FOPS.

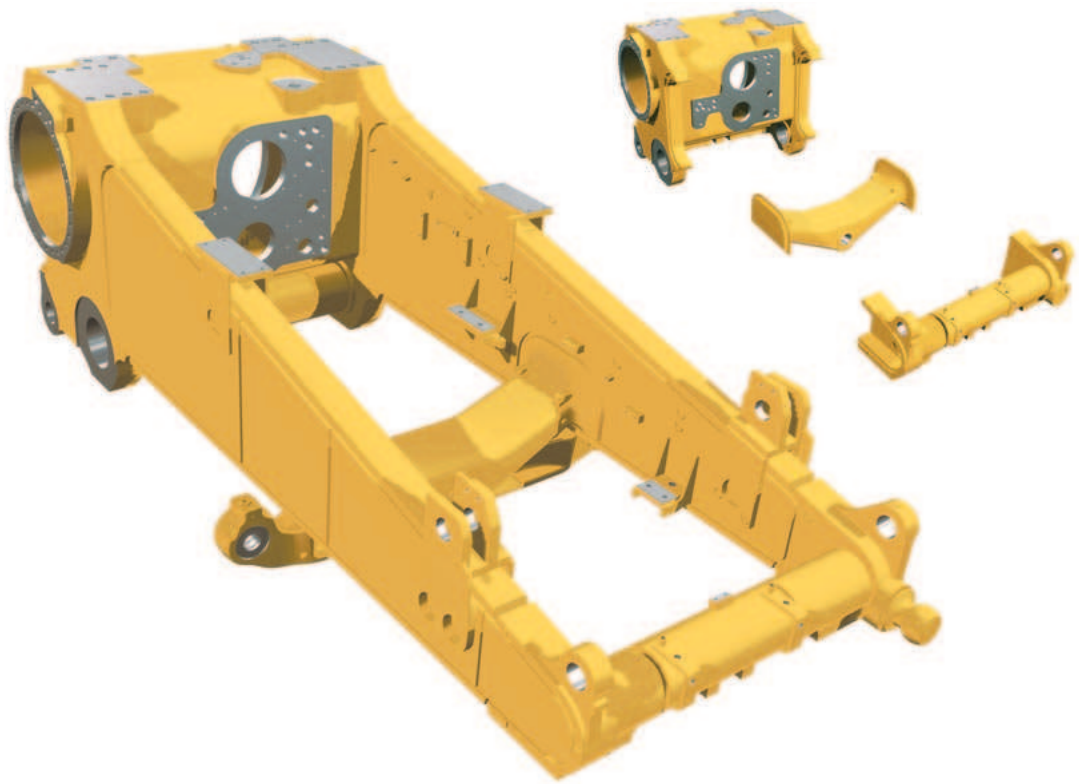

Structure

Engineered for maximum production and service life.

Mainframe

The D9R mainframe is built to absorb high impact shock loads and twisting forces.

Heavy Steel Castings

Heavy steel castings give added strength to the main case, equalizer bar saddle, front cross member and tag-link trunnion.

Frame Rails

Full box section, designed to keep components rigidly aligned.

Top and Bottom Rails

Continuous rolled sections with no machining or welding providing superior mainframe durability.

Main Case

Elevates the final drives well above the ground level work area to protect them from impact loads, abrasion and contaminants.

Pivot Shaft and Pinned Equalizer Bar

Maintain track roller frame alignment.

Undercarriage

Designed for better machine balance and component life.

Suspended Undercarriage Design

Absorbs impact loads to reduce the shock loads transferred to the undercarriage by up to 50%.

Bogie Suspension

Provides more ground contact, especially in hard, uneven terrain. Higher traction means less slippage, better balance, and a smoother ride.

Rollers and Idlers

Feature symmetric Duo-Cone™ seals. Idler caps have an additional third bolt in the abutment-style joint.

Roller Frames

Tubular design resists bending and twisting and includes added reinforcement where operating loads are the highest. Alignment is optimized for undercarriage wear, and increased track frame adjustment length provides more wear material for use, extending link and roller wear life.

Elevated Sprocket

Transfers implement shock loads to the mainframe and allows the sprockets, final drives, axles and steering components to perform without absorbing excessive punishment. This allows Cat tractors to work harder and last longer than competitors' machines. The sprocket segment design increases the life of both the segment and track bushing.

Traction

The elevated sprocket allows more track to the rear of the roller frame, increasing traction and flotation and counteracting front-end rise during heavy dozing and drawbar applications. With more track on the ground, the D9R delivers exceptional balance, stability, and traction for excellent dozer penetration and productive ripping.

Positive Pin Retention (PPR) Sealed and Lubricated Track

Designed for high-impact and high load applications. The PPR exclusive Caterpillar design locks the link to the pin reducing the opportunity for premature loss of lubrication. Sealed design permanently coats the track pin with lubricant, minimizing metal-to-metal contact and virtually eliminating internal pin and bushing wear.

Other Features

- Large pivot shaft bushings operate in an oil reservoir.
- A low friction, no maintenance bushing is used in the saddle connection.
- Resilient pads restrain equalizer bar oscillation.
- Idler Guards (optional), increase undercarriage life.

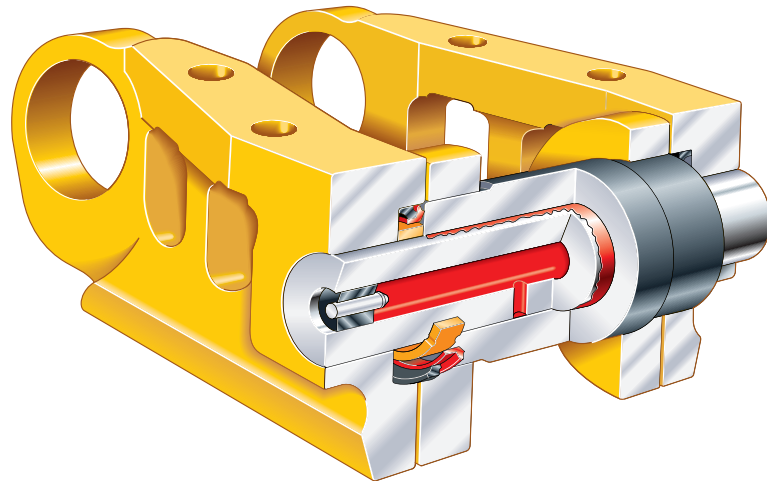

Work Tools

Work Tools provide the flexibility to match the machine to the job.



Bulldozers

Blades are made of Cat DH-2™ steel with high tensile strength and stands up to the most severe applications. Heavy moldboard construction and bolt-on cutting edges and end bits add strength and durability.

- Universal Blade – Efficient at moving big loads over long distances.
- Semi-Universal Blade – Built for tough applications in tightly packed material where penetration is important.
- Optional Dual Tilt – Allows the operator to optimize the blade pitch angle for each portion of the dozing cycle.
- Cutting Edges and End Bits – Cutting edges are DH-2™ steel. End bits are DH-3™ to provide maximum service life in tough materials.

Rippers

- Multi-Shank Ripper – Tailors the tractor to the material by using one, two or three shanks.
- Single-Shank Ripper – Operator can adjust the shank depth from the seat using an optional single shank pin puller. Large one-piece shank, available in deep rip configuration.

Single Lever Control

A single lever controls all blade movements, including the optional dual tilt.

Tag-Link

Tag-Link construction brings the blade closer to the machine for more precise dozing and load control. The tag-link design provides solid lateral stability and better cylinder positions for constant pryout independent of blade height.

Heel Clearance

Works well in hard-to-penetrate material because of excellent heel clearance.

Ground Engaging Tools (GET)

A large range of Ground Engaging Tools are offered.

Hydraulics

Automatically adjusts work tool hydraulic power to maximize machine efficiency.



Serviceability

The most serviceable machines from the most committed dealers.

Built-In Servicing Ease

Major components are made as modules and can be removed without disturbing or removing others.

Spin-On Filters

Spin-on fuel and engine oil filters save changing time. Further time is saved with fast fuel and quick oil change attachments.

Electrical Connectors

To improve electrical system reliability and servicing, sealed electrical connectors are used in most locations. The harness connectors lock out dust and moisture better than “bullet” or “metal twist” connectors.

Ecology Drains

Provide an environmentally safer method to drain fluids. Included on the radiator, hydraulic tank and major power train components.

Easier Maintenance and Repair

Experience easier maintenance and repair through monitoring key functions and logging critical indicators. Electronic diagnostic access is possible with a single tool, the Electronic Technician (Cat ET).

Quick Disconnect Fittings

Allow for fast diagnosis of the power train and implement oil systems.

Fuel Tank

Increased fuel tank capacity for a full, non-stop shift between refills. Fast fuel attachment with positive fuel shut-off to prevent fuel spillage.

Customer Support

The Cat dealer network keeps your fleet up and running.



Dealer Commitment

Dealers committed to fast, quality customer support. Your Cat dealer's investment in service begins with the fastest and most complete parts availability in the industry.

Financing

Your dealer is also an expert at arranging affordable lease, rental or purchase financing for all Caterpillar products. Consider the financing options available as well as the day-to-day operating costs.

Machine Selection

Make detailed comparisons of the machines you are considering before you buy. How long do components last? What is the cost of preventive maintenance? What is the true cost of lost production? Your Cat dealer can give you answers to these questions.

Replacement

Repair, rebuild, or replace? Your Cat dealer can help evaluate the cost involved so you can make the right choice.

Product Support

Plan for effective maintenance before buying equipment. Choose from your dealer's wide range of maintenance services at the time you purchase your machine. Programs such as Custom Track Service (CTS), S•O•SSM analysis, Technical Analysis and guaranteed maintenance contracts give peak life and performance to your machine.

Parts Program

You will find nearly all parts at your dealer parts counter. Cat dealers use a world-wide computer network to find in-stock parts to minimize machine down time. Ask about your Cat dealer's exchange program for major components. This can shorten repair time and lower costs.

Remanufactured Components

Save money with remanufactured parts. You receive the same warranty and reliability as new products at a cost savings of 40 to 70 percent.

D9R Track-Type Tractor Specifications

Dimensions

All dimensions are approximate.

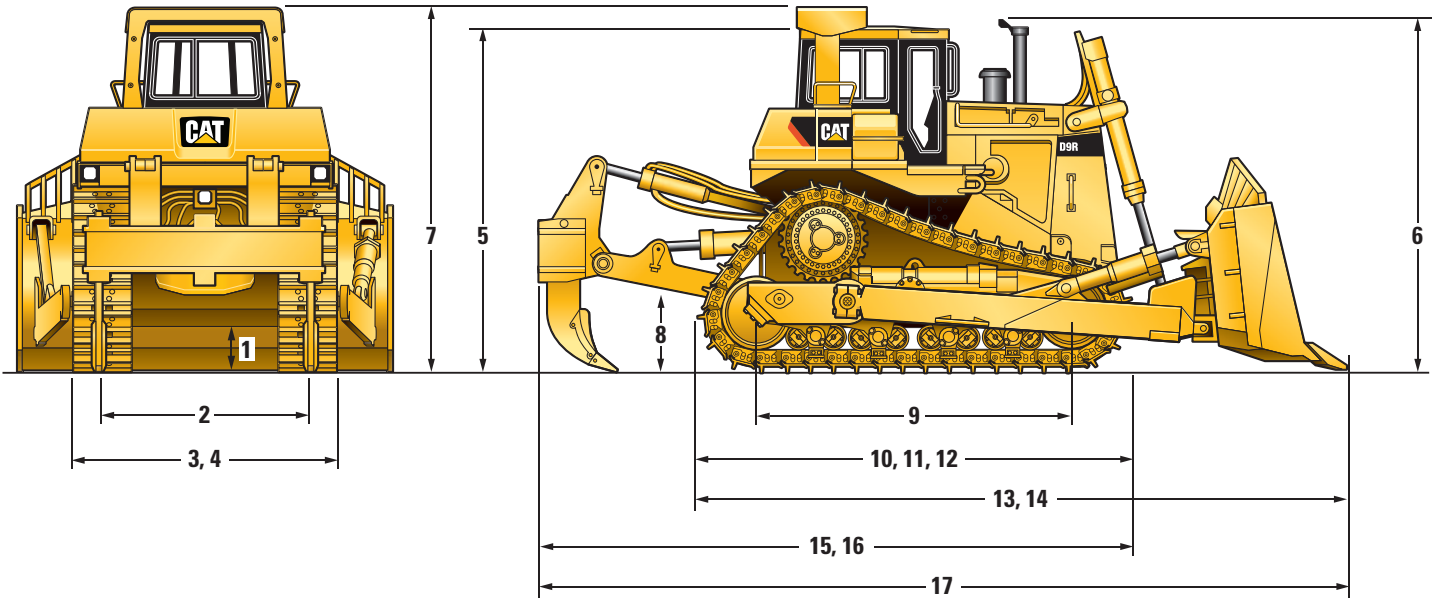

	mm	in
1 Ground Clearance	588	23.1
2 Track Gauge	2250	88.6
3 Width without Trunnions (Standard Shoe)	2898	114.1
4 Width Over Trunnions	3308	130.2
5 Height (FOPS Cab)	3821	150.4
6 Height (Top of Stack)	4005	157.7
7 Height (ROPS/Canopy)	3998	157.4
8 Drawbar Height (Center of Clevis)	765	30.1
9 Length of Track on Ground	3474	136.8
10 Overall Length Basic Tractor	4908	193.2
11 Length Basic Tractor with Drawbar	5243	206.4
12 Length Basic Tractor with Winch	5545	218.3
13 Length with SU-Blade	6592	259.5
14 Length with U-Blade	6931	272.9
15 Length with Single-Shank Ripper	6529	257.0
16 Length with Multi-Shank Ripper	6539	257.4
17 Overall Length (SU-Blade/SS Ripper)	8214	323.4

D9R Track-Type Tractor Specifications

Engine

Engine Model	Cat 3408C	
Gross Power	330 kW	443 hp
Net Power		
SAE J1349/ ISO 9249	302 kW	405 hp
EU 80/1269	302 kW	405 hp
Bore	137 mm	5.4 in
Stroke	152 mm	6 in
Displacement	18 L	1,099 in ³

- Engine ratings apply at 1,900 rpm
- Net power advertised is the power available at the flywheel when the engine is equipped with fan, air cleaner, muffler and alternator.
- No derating required up to 2286 m (7,500 ft) altitude.

Service Refill Capacities

Fuel Tank	889 L	235 gal
Cooling System	125 L	33 gal
Engine Crankcase*	45.5 L	12 gal
Power Train	164 L	43.4 gal
Final Drives (each)	15 L	3.9 gal
Roller Frames (each)	45 L	11.9 gal
Pivot Shaft Compartment	30 L	7.9 gal
Hydraulic Tank	77.2 L	20.4 gal

* With oil filters.

Weights

Operating Weight	48 784 kg	107,550 lb
Shipping Weight	36 154 kg	79,705 lb

- Operating Weight: Includes clutch/brake arrangement, lubricant, coolant, 100% fuel, hydraulic controls and fluids, 610 mm (24 in) extreme service shoes, SU-Blade, single-shank ripper, ROPS, FOPS cab and operator.
- Shipping Weight: Includes clutch/brake arrangement, lubricants, coolant, 20% fuel and ROPS, FOPS cab and 610 mm (24 in) extreme service shoes.

Undercarriage

Shoe Type	Extreme Service	
Width of Shoe	610 mm	24 in
Shoes/Side	43	
Grouser Height	84 mm	3.3 in
Pitch	240 mm	9.44 in
Ground Clearance	591 mm	23 in
Track Gauge	2250 mm	88.58 in
Length of Track on Ground	3474 mm	11 ft 5 in
Ground Contact Area	4.24 m ²	6,569 in ²
Track Rollers/Side	8	

- Positive Pin Retention Track.

Hydraulic Controls

Pump Type	Piston-type geared from flywheel	
Pump Output (Implement)	239 L/min	63.1 gal/min
Tilt Cylinder Rod End Flow	137 L/min	36.4 gal/min
Tilt Cylinder Head End Flow	167 L/min	44.2 gal/min
Bulldozer Relief Valve Setting	26 200 kPa	3,800 psi
Tilt Cylinder Relief Valve Setting	19 300 kPa	2,800 psi
Ripper (Lift) Relief Valve Setting	26 200 kPa	3,800 psi
Ripper (Pitch) Relief Valve Setting	26 200 kPa	3,800 psi

- Implement Pump output measured at 1,900 rpm and 6895 kPa (1,000 psi).
- Complete system consists of pump, tank with filter, valves, lines, linkage and control levers.

Transmission

1 Forward	3.9 km/h	2.4 mph
2 Forward	6.8 km/h	4.2 mph
3 Forward	11.9 km/h	7.4 mph
1 Reverse	4.8 km/h	3 mph
2 Reverse	8.4 km/h	5.2 mph
3 Reverse	14.7 km/h	9.1 mph
1 Forward – Drawbar Pull (1000)	725 N	163 lbf
2 Forward – Drawbar Pull (1000)	400 N	90 lbf
3 Forward – Drawbar Pull (1000)	218 N	49 lbf

Blades

Type	9SU	
Capacity (SAE J1265)	13.5 m ³	17.7 yd ³
Width (over end bits)	4310 mm	14 ft 2 in
Height	1934 mm	6 ft 4 in
Digging Depth	606 mm	23.9 in
Ground Clearance	1422 mm	56 in
Maximum Tilt	940 mm	37 in
Weight* (without hydraulic controls)	6543 kg	14,425 lb
Total Operating Weight** (with Blade and Single-Shank Ripper)	48 784 kg	107,548 lb

Type	9U	
Capacity (SAE J1265)	16.4 m ³	21.4 yd ³
Width (over end bits)	4650 mm	15 ft 3 in
Height	1934 mm	6 ft 4 in
Digging Depth	606 mm	23.9 in
Ground Clearance	1422 mm	56 in
Maximum Tilt	1014 mm	39.9 in
Weight* (without hydraulic controls)	7134 kg	15,727 lb
Total Operating Weight** (with Blade and Single-Shank Ripper)	49 392 kg	108,890.59 lb

* Includes blade tilt cylinder.

** Total Operating Weight: Includes hydraulic controls, blade tilt cylinder, coolant, lubricants, 100% fuel, ROPS, FOPS cab, Blade, Single-Shank Ripper, 610 mm (24 in) ES shoes, and operator.

Rippers

Type	Single-Shank, Adjustable Parallelogram	
Added Length	1570 mm	5 ft 2 in
Number of Pockets	1	
Maximum Clearance Raised (under tip, pinned in bottom hole)	882 mm	34.7 in
Maximum Penetration (standard tip)	1231 mm	48.5 in
Maximum Penetration Force** (shank vertical)	153.8 kN	34,581 lb
Pry out Force	320.5 kN	72,025 lb
Weight (without hydraulic controls)	4854 kg	10,700 lb
Total Operating Weight* (with SU-Blade and Ripper)	48 784 kg	107,548 lb

Type	Multi-Shank, Adjustable Parallelogram	
Number of Pockets	3	
Added Length	1330 mm	4 ft 4 in
Overall Beam Width	2640 mm	103.9 in
Maximum Clearance Raised (under tip, pinned in bottom hole)	885 mm	34.8 in
Maximum Penetration (standard tip)	798 mm	31.4 in
Maximum Penetration Force** (shank vertical)	147.9 kN	33,249 lb
Pry out Force (Multi-Shank Ripper with one tooth)	324.6 kN	74,639 lb
Weight (one shank, without hydraulic controls)	5449 kg	12,236 lb
Additional Shank	340 kg	749 lb
Total Operating Weight* (with SU-Blade and Ripper)	49 479 kg	109,082 lb

* Total Operating Weight: Includes hydraulic controls, blade tilt cylinder, coolant, lubricants, 100% fuel, ROPS, FOPS cab, SU-Blade, Ripper, 610 mm (24 in) ES shoes, and operator.

** Single-Shank cross section is larger than Multi-Shank cross section.

Winches

Winch Model	PA140VS	
Weight*	1790 kg	3,950 lb
Oil Capacity	15 L	4 gal
Increased Tractor Length	559 mm	22 in
Winch Case Width	1171 mm	46.1 in
Drum Width	337 mm	13.25 in
Flange Diameter	610 mm	24 in

* Weight: Includes pump and operator controls. With counterweight: 3705 kg (8,169 lb).

Standards

- ROPS (Rollover Protective Structure) offered by Caterpillar for the machine meets ROPS criteria SAE J1040 MAY94, ISO 6396:2008.
- FOPS (Falling Object Protective Structure) meets SAE J1503449 APR98 Level II, and ISO 3449:1992 Level II.
- The operator sound exposure Leq (equivalent sound pressure level) measured according to the work cycle procedures specified in ANSI/SAE J1166 OCT98 is 83 dB(A), for cab offered by Caterpillar, when properly installed and maintained and tested with the doors and windows closed.
- Hearing protection may be needed when operating with an open operator station and cab (when not properly maintained or doors/ windows open) for extended periods or in noisy environment.
- Brakes meet the standard SAE J/ISO 10265 MAR99.

D9R Standard Equipment

Standard equipment may vary. Consult your Cat dealer for details.

ELECTRICAL

- Alternator, 75 amp
- Back-up alarm
- Batteries, 12-volt (2), 190 amp-hour
- Horn, forward warning
- Lighting system, halogen
(2 forward, 2 rear)
- Starting Receptacle

OPERATOR ENVIRONMENT

- Canopy, ROPS/FOPS
- Cat D9R Monitoring System
- Decelerator and governor control
- Hydraulic control lever restraints
- Hydraulic system, four valve
- Mirror, rearview
- Seat, vinyl suspension
- Seat belt, retractable 76 mm (3 in)

UNDERCARRIAGE

- 610 mm (24 in) extreme service grouser
with sealed and lubricated PPR track
(43 section)

- Lifetime lubricated rollers and idlers
- Pinned equalizer bar
- Sprocket rim segments, replaceable
- Suspension-type undercarriage, eight-
roller tubular track roller frame
- Track adjusters, hydraulic
- Track guides
- Two-piece master links

POWER TRAIN

- 3408C DITA diesel engine
- Advanced Modular Cooling System
(AMOCS)
- Blower fan
- Clutch-brake with combined steering and
brake control levers
- Coolant, extended life
- Drains, ecology fluid
- Ether starting aid
- Final drives, 3 planet double reduction
planetary
- Fuel priming pump
- Muffler

- Power shift transmission (3F/3R)
- Precleaner with dust ejector
- Prescreener
- Separator, water/fuel
- Thermal shield
- Torque divider

OTHER STANDARD EQUIPMENT

- CD ROM parts book
- Engine enclosure
- Guards – Bottom, hinged extreme service
with front towing device
- Load sensing hydraulics
- Mounting, lift cylinders
- Radiator, hinged
- Rain cap
- Service instructions, international
- Vandalism protection (8 caplocks)

Optional equipment may vary. Consult your Cat dealer for details.

ELECTRICAL

- Alternator, 100 amp
- Converter, 24-volt to 12-volt
- Lights, supplemental (3 variations)

GUARDS

- Dozer lines
- Final drive seals
- Fuel tank
- Pivot shaft seals
- Undercarriage

OPERATOR ENVIRONMENT

- Air conditioner (2 variations)
- Cab
- Glass, dual pane with fan defroster
- Seat, air suspension

POWER TRAIN

- Fast fuel system
- Fast oil change system
- Grid, radiator core protector
- Precleaner, turbine
- Prelub engine

UNDERCARRIAGE

- Tracks, sealed and lubricated
- 560 mm (22 in) PPR Extreme Service
- 685 mm (27 in) PPR Extreme Service
- 760 mm (30 in) PPR Extreme Service
- Carrier Rollers

SPECIAL ARRANGEMENTS

- Arctic package
- Cold weather package
- DCA 1 Heavy Construction Lane 1
- DCA 2 Arctic Lane 1
- Desert arrangement
- Steel mill arrangement

BULLDOZER ARRANGEMENTS

- 9SU abrasion resistant blade
- 9U abrasion resistant blade
- Trunnions

HYDRAULIC CONTROLS

- Dual tilt

RIPPERS

- Single shank
- Multi shank
- Pin puller (single shank only)
- Push block (single shank only)
- Ripper shank (multiple variations)

OTHER ATTACHMENTS

- Counterweights (rear and additional)
- Drawbar, rigid
- Heater, Espar coolant
- Low temperature start
(includes two additional batteries)
- Omission, engine enclosure
- Paint, black hood and cylinders
- Winch (with counterweight)

D9R Track-Type Tractor

For more complete information on Cat products, dealer services, and industry solutions, visit us on the web at www.cat.com

© 2011 Caterpillar Inc.
All rights reserved

AEHQ6100 (2-2011)

Materials and specifications are subject to change without notice. Featured machines in photos may include additional equipment. See your Cat dealer for available options.

CAT, CATERPILLAR, SAFETY.CAT.COM, their respective logos, "Caterpillar Yellow" and the "Power Edge" trade dress, as well as corporate and product identity used herein, are trademarks of Caterpillar and may not be used without permission.

