

226D/232D/236D/ 242D/246D/262D

Skid Steer Loaders



Engine	226D		232D		236D		242D		246D		262D	
Gross Power (SAE J1995)	50.1 kW	67.1 hp	50.1 kW	67.1 hp	55.4 kW	74.3 hp	55.4 kW	74.3 hp	55.4 kW	74.3 hp	55.4 kW	74.3 hp
Weights												
Operating Weight	2588 kg	5,705 lb	2818 kg	6,213 lb	2975 kg	6,559 lb	3166 kg	6,980 lb	3368 kg	7,424 lb	3634 kg	8,011 lb
Operating Specifications												
Rated Operating Capacity	703 kg	1,550 lb	839 kg	1,850 lb	818 kg	1,800 lb	975 kg	2,150 lb	975 kg	2,150 lb	1225 kg	2,700 lb

226D/232D/236D/242D/246D/262D Features

Industry Leading Cab

One piece, modular design provides a premium sealed and pressurized cab for a cleaner and quieter operating environment with excellent all around visibility.

Superior Power

High performance power train provides maximum performance with features such as Electronic Torque Management system, optional two speed and an electronic hand/foot throttle with decel pedal capability.

Powerful Hydraulics

High flow hydraulic system available for applications that demand maximum hydraulic work tool performance.

Outstanding Performance

Cat® Intelligent Leveling (ILEV) system enables industry leading features such as dual direction electronic self level, return-to-dig and work tool positioner.

Versatility

Do more with one machine with the broad range of performance matched Cat Work Tools, built to get the most out of your machine.

Contents

Operator Station.....	4
Power Train.....	6
Lift Linkages.....	6
Performance.....	7
Attachments.....	8
Serviceability.....	9
Customer Support.....	9
Specifications.....	10
Standard Equipment.....	16
Mandatory Equipment.....	17
Optional Equipment.....	17
Notes.....	18





Experience the difference of a Cat Skid Steer Loader. Spacious operator station features ergonomic joystick controls, ample leg room and an available high back, heated, air ride seat to keep you comfortable all day long. Built for outstanding performance, comfort and versatility, the Cat D Series Skid Steer Loaders help you get more done to improve your bottom line.

Operator Station

Spacious working environment for all day comfort.



Base Display

The standard control monitor provides a single-code security to help prevent theft and unwanted operation.

Best Seat on the Job Site

High back, heated, air ride seat available in both cloth and vinyl.





Superior Comfort

The Cat D Series sets a new standard in operator comfort. The wide, spacious interior and uncluttered floor helps you work comfortably and productively all day long. Features include:

- One piece, modular design provides a premium sealed and pressurized cab for cleaner and quieter working environment
- High back, heated, air ride seat with seat-mounted joystick controls for added comfort (option)
- Clear sight lines provide excellent visibility
- Air conditioner and heater for greater comfort in all climates (option)
- Ample leg room
- Selectable Pattern Control which allows the operator to select the control pattern they are most familiar with for greater productivity (option)

Advanced Display Panel

The optional Advanced Display lets you customize your machine performance to your needs by offering the ultimate in operator control features and functionality. This easy to read 127 mm (5 in) LCD display puts machine information at your fingertips. It provides on screen adjustments to working parameters and preferences such as implement response adjustment, drive response adjustment, creep setting, ride control activation speed, top speed limit setting, language, background color and gauge display style. All parameters can be customized and retained for each individual operator's code. It also provides:

- Security system to prevent unauthorized machine usage
- Capability to program up to 50 operator codes to store and recall each operator's preferences and working parameters, allowing the machine to be tailored to experience level and application
- Integrated rearview camera for additional job site visibility (option)



Power Train

Aggressive performance.



Vertical Lift Linkage



Radial Lift Linkage

Lift Linkages

Choice of lift designs.

Two types of lifting arrangement are available – vertical lift and radial lift – to meet your specific application needs.

Vertical Lift

The 232D, 242D and 262D feature the vertical lift design which provides extended reach and lift height for material handling or quick and easy truck loading.

Radial Lift

The 226D, 236D and 246D feature the radial lift design which delivers excellent digging performance and superior mid-lift reach.

Cat Engine

The electronically controlled Cat C2.2 and C3.3B engines provide high horsepower and torque. These rugged, reliable engines meet U.S. EPA Tier 4 Final/EU Stage IIIB emission standards.

Cat Intelligent Leveling (ILEV) System

The exclusive Cat Intelligent Leveling System takes machine performance to a new level and provides industry leading features such as:

- Electronic Dual Self Leveling that allows the operator to automatically maintain a level load whether lifting or lowering
- Electronic snubbing that automatically cushions the descent of the lift arms, slowing the downward motion just before the arms reach their stops
- Return-to-dig which allows the operator to pre-set the digging angle of the bucket and then automatically lowers the lift arms and recalls the bucket angle
- Work Tool Positioner which allows the angle of the work tool (bucket, box rake, cold planer, forks, trencher, etc.) to be pre-set and then automatically recalled if the machine is repositioned, increasing productivity

Electronic Throttle

An electronic dial-type throttle lets you set precise RPM setting. When the dial is in the high-idle position, the foot throttle functions as a decelerator pedal. This gives you greater control, allowing you to quickly adjust the travel speed during precise maneuvers or to regulate engine speed when using hydro-mechanical work tools. The throttle-smoothing feature monitors the accelerator pedal's movement under the operator's foot when traveling over rough terrain and adjusts to provide a steadier, more even travel speed.





Performance

Solutions for a wide range of applications.

High Performance Hydraulic System

Maximum power and reliability are built into the Cat hydraulic system to help you get the job done faster. The hydraulic system features outstanding lift and breakout forces. The standard demand fan provides improved fuel efficiency and increased horsepower.

High Flow Hydraulic Systems

High Flow (226D/232D/236D/242D) and High Flow XPS (246D/262D) hydraulic systems are available for applications that demand maximum work tool performance.

Two Speed Option

Increase your productivity with the optional Two Speed.

Ride Control

The optional Speed Sensitive Ride Control system delivers a smoother ride on uneven terrain for superior comfort, higher speed operation and better material retention.

Attachments

Do more jobs with one machine using Cat Work Tools.

The Right Tool for the Job

Designed and built for optimum performance and durability, Cat Work Tools deliver high productivity in a variety of applications to maximize versatility:

- Augers
- Backhoes
- Blades (angle, dozer)
- Buckets (general purpose, high capacity, dirt, utility, light material, multi purpose, industrial grapple, utility grapple)
- Brooms (angle, pickup, utility)
- Brushcutters
- Cold Planers
- Forks (pallet, industrial grapple, utility grapple, utility)
- Hydraulic Hammers
- Landscape Tillers
- Landscape Rakes
- Material Handling Arm
- Mulchers
- Power Box Rakes
- Sectional Snow Push
- Shear
- Snow Blowers
- Stump Grinders
- Trenchers
- Vibratory Compactors
- Wheel Saws

Quick Couplers

Work tools can be changed quickly and easily with the Cat Skid Steer Loader's quick coupler system. The standard quick coupler features manual engagement and disengagement of work tools using two high leverage handles. The optional electric quick coupler allows the operator to quickly change tools without leaving the cab.



Serviceability

Easy maintenance helps keep your machine working.

Minimize Your Downtime

Convenient service features make maintenance easy, reducing your downtime:

- Unmatched ground level access to all routine service points
- Wide opening rear door for easy access to both sides of the engine
- Electric priming pump with automatic air bleed for the fuel system eliminates the need to pre-fill filters with fuel, reducing the risk of contaminants
- Cat Product Link™ system provides remote reporting of machine location and operating system parameters (optional)

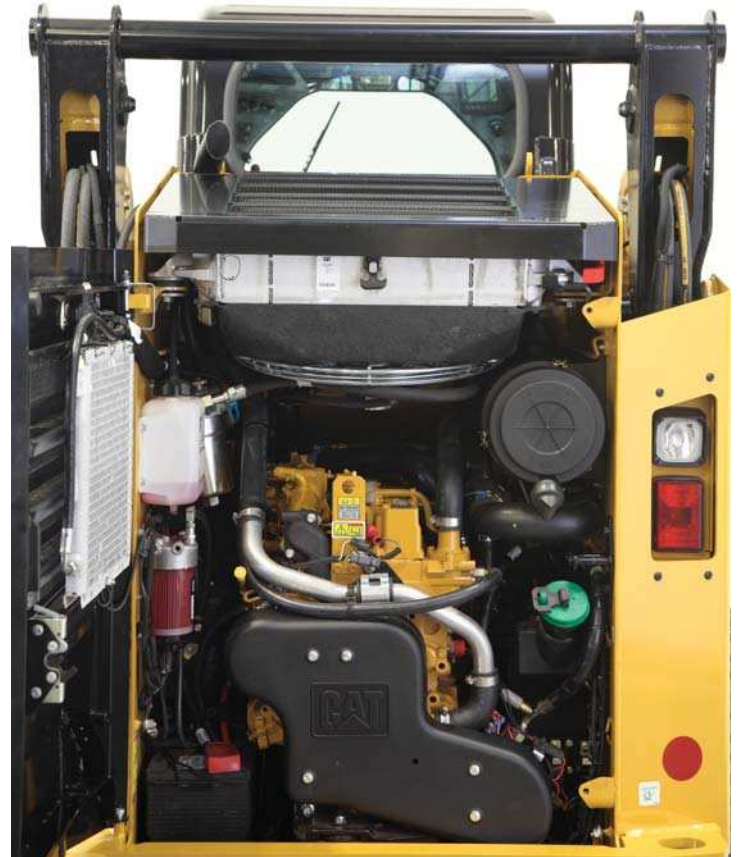

Customer Support

Unmatched support makes the difference.



Renowned Dealer Support

From helping you choose the right machine to knowledgeable ongoing support, Cat dealers provide the best in sales and service.

- Preventive maintenance programs and guaranteed maintenance contracts
- Best-in-class parts availability
- Operator training to help boost your profits
- Genuine Cat Remanufactured parts

226D/232D/236D/242D/246D/262D Skid Steer Loaders Specifications

Engine

Engine Model			
226D/232D	Cat C2.2 (turbo)		
236D/242D/246D/262D	Cat C3.3B DIT (turbo)		
Gross Power (SAE J1995)			
226D/232D	50.1 kW	67.1 hp	
236D/242D	55.4 kW	74.3 hp	
246D/262D	55.4 kW	74.3 hp	
Net Power (SAE 1349)			
226D/232D	49.1 kW	65.8 hp	
236D/242D	54.6 kW	73.2 hp	
246D/262D	54.4 kW	72.9 hp	
Net Power (ISO 9249)			
226D/232D	49.6 kW	66.5 hp	
236D/242D	55.1 kW	73.9 hp	
246D/262D	54.9 kW	73.7 hp	
Displacement			
226D/232D	2.2 L	134.3 in ³	
236D/242D/246D/262D	3.3 L	203 in ³	
Stroke			
226D/232D	100 mm	3.9 in	
236D/242D/246D/262D	120 mm	4.7 in	
Bore			
226D/232D	84 mm	3.3 in	
236D/242D/246D/262D	94 mm	3.7 in	

Weights*

Operating Weight			
226D	2588 kg	5,705 lb	
232D	2818 kg	6,213 lb	
236D	2975 kg	6,559 lb	
242D	3166 kg	6,980 lb	
246D	3368 kg	7,424 lb	
262D	3634 kg	8,011 lb	

Power Train

Travel Speed (Forward or Reverse)			
One Speed			
226D/232D	12.3 km/h	7.6 mph	
236D	11.2 km/h	7.0 mph	
242D	12.1 km/h	7.5 mph	
246D/262D	12.5 km/h	7.7 mph	
Two Speed Option			
226D/232D	17.8 km/h	11.1 mph	
236D	17.1 km/h	10.6 mph	
242D	18.5 km/h	11.5 mph	
246D/262D	17.7 km/h	11.0 mph	

Operating Specifications*

Rated Operating Capacity			
226D	703 kg	1,550 lb	
232D	839 kg	1,850 lb	
236D	818 kg	1,800 lb	
242D	975 kg	2,150 lb	
246D	975 kg	2,150 lb	
262D	1225 kg	2,700 lb	
Rated Operating Capacity with Optional Counterweight			
226D	749 kg	1,650 lb	
232D	885 kg	1,950 lb	
236D	900 kg	2,000 lb	
242D	1066 kg	2,350 lb	
246D	1088 kg	2,400 lb	
262D	1338 kg	2,950 lb	
Tipping Load			
226D	1407 kg	3,100 lb	
232D	1679 kg	3,700 lb	
236D	1633 kg	3,600 lb	
242D	1950 kg	4,300 lb	
246D	1950 kg	4,300 lb	
262D	2449 kg	5,400 lb	
Breakout Force, Tilt Cylinder			
226D	1807 kg	3,983 lb	
232D	1807 kg	3,983 lb	
236D	2302 kg	5,074 lb	
242D	2283 kg	5,034 lb	
246D	3336 kg	7,355 lb	
262D	3336 kg	7,355 lb	

226D/232D/236D/242D/246D/262D Skid Steer Loaders Specifications

Hydraulic System – 226D and 232D

Hydraulic Flow – Standard		
Loader Hydraulic Pressure	23 000 kPa	3,336 psi
Loader Hydraulic Flow	69 L/min	18 gal/min
Hydraulic Power (calculated)	26.5 kW	35.5 hp

Hydraulic Flow – High Flow		
Maximum Loader Hydraulic Pressure	23 000 kPa	3,336 psi
Maximum Loader Hydraulic Flow	99 L/min	26 gal/min
Hydraulic Power (calculated)	38.0 kW	50.9 hp

Hydraulic System – 236D and 242D

Hydraulic Flow – Standard		
Loader Hydraulic Pressure	23 000 kPa	3,336 psi
Loader Hydraulic Flow	76 L/min	20 gal/min
Hydraulic Power (calculated)	29 kW	39 hp

Hydraulic Flow – High Flow		
Maximum Loader Hydraulic Pressure	23 000 kPa	3,336 psi
Maximum Loader Hydraulic Flow	112 L/min	30 gal/min
Hydraulic Power (calculated)	43 kW	58 hp

Hydraulic System – 246D and 262D

Hydraulic Flow – Standard		
Loader Hydraulic Pressure	23 000 kPa	3,336 psi
Loader Hydraulic Flow	86 L/min	23 gal/min
Hydraulic Power (calculated)	33 kW	44 hp

Hydraulic Flow – High Flow XPS		
Maximum Loader Hydraulic Pressure	28 000 kPa	4,061 psi
Maximum Loader Hydraulic Flow	121 L/min	32 gal/min
Hydraulic Power (calculated)	57 kW	76 hp

Cab

ROPS	ISO 3471:2008
FOPS	ISO 3449:2005 Level I
FOPS Level II	ISO 3449:2005 Level II

Service Refill Capacities

Chain Box, each side		
226D/232D	7 L	1.8 gal
236D/242D	8.8 L	2.3 gal
246D/262D	12.7 L	3.3 gal

Cooling System		
226D/232D	12 L	3.2 gal
236D/242D/246D/262D	14 L	3.7 gal

Engine Crankcase		
226D/232D	10 L	2.6 gal
236D/242D/246D/262D	11 L	3.0 gal

Fuel Tank		
226D/232D	57 L	15.1 gal
236D/242D	105 L	27.7 gal
246D/262D	94 L	24.8 gal

Hydraulic System		
226D/232D	45 L	11.9 gal
236D/242D	50 L	13.2 gal
246D/262D	52 L	13.7 gal

Hydraulic Tank		
226D/232D	34 L	9.0 gal
236D/242D/246D/262D	39 L	10.3 gal

226D Skid Steer Loaders Specifications

Dimensions*

All dimensions are approximate.

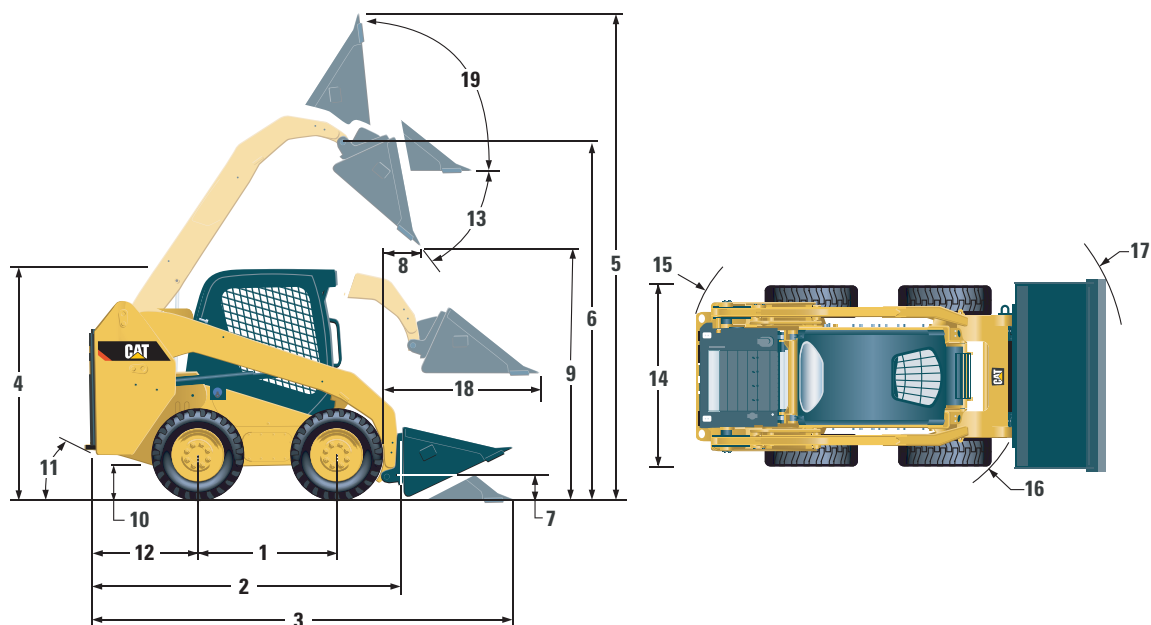

	226D	
1 Wheelbase	1054 mm	41.5 in
2 Length without Bucket	2524 mm	99.4 in
3 Length with Bucket on Ground	3234 mm	127.3 in
4 Height to Top of Cab	2028 mm	79.8 in
5 Maximum Overall Height	3652 mm	143.8 in
6 Bucket Pin Height at Maximum Lift	2818 mm	110.9 in
7 Bucket Pin Height at Carry Position	215 mm	8.5 in
8 Reach at Maximum Lift and Dump	533 mm	21.0 in
9 Clearance at Maximum Lift and Dump	2077 mm	81.8 in
10 Ground Clearance	175 mm	6.9 in
11 Departure Angle		27.9°
12 Bumper Overhang behind Rear Axle	894 mm	35.2 in
13 Maximum Dump Angle		46.7°
14 Vehicle Width over Tires	1497 mm	58.9 in
15 Turning Radius from Center – Machine Rear	1513 mm	59.6 in
16 Turning Radius from Center – Coupler	1104 mm	43.5 in
17 Turning Radius from Center – Bucket	1977 mm	77.8 in
18 Maximum Reach with Arms Parallel to Ground	1288 mm	50.7 in
19 Rack Back Angle at Maximum Height		88.9°

*Operating Weight, Operating Specifications and Dimensions all based on 75 kg (165 lb) operator, all fluids, single speed, 1524 mm (60 in) dirt bucket, Cat 10 × 16.5 tires, standard flow hydraulics, C0 cab (OROPS, static seat), 880 CCA battery, manual quick coupler, no self level and no optional counterweights (unless otherwise noted).

236D/246D Skid Steer Loaders Specifications

Dimensions*

All dimensions are approximate.

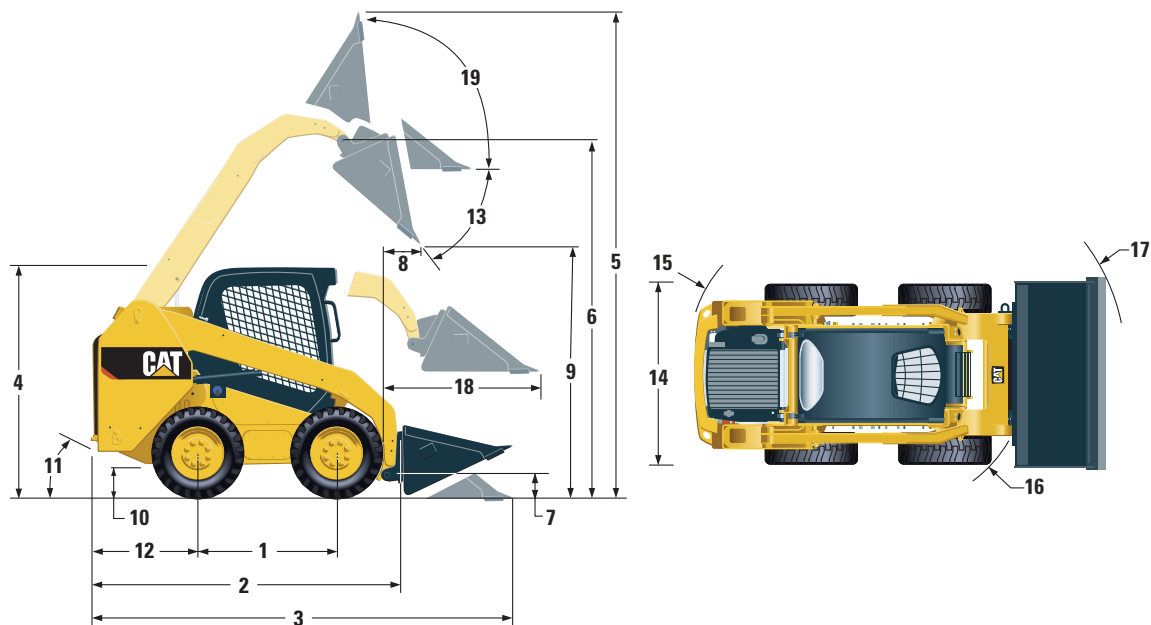

	236D		246D	
1 Wheelbase	1105 mm	43.5 in	1249 mm	49.2 in
2 Length without Bucket	2767 mm	108.9 in	2993 mm	117.8 in
3 Length with Bucket on Ground	3487 mm	137.3 in	3708 mm	146.0 in
4 Height to Top of Cab	2082 mm	82.0 in	2110 mm	83.1 in
5 Maximum Overall Height	3977 mm	156.6 in	4032 mm	158.7 in
6 Bucket Pin Height at Maximum Lift	3122 mm	122.9 in	3154 mm	124.2 in
7 Bucket Pin Height at Carry Position	190 mm	7.5 in	200 mm	7.9 in
8 Reach at Maximum Lift and Dump	408 mm	16.0 in	600 mm	23.6 in
9 Clearance at Maximum Lift and Dump	2359 mm	92.9 in	2465 mm	97.1 in
10 Ground Clearance	195 mm	7.7 in	226 mm	8.9 in
11 Departure Angle		26°		26°
12 Bumper Overhang behind Rear Axle	1021 mm	40.2 in	1083 mm	42.6 in
13 Maximum Dump Angle		48°		39°
14 Vehicle Width over Tires	1676 mm	66.0 in	1676 mm	66 in
15 Turning Radius from Center – Machine Rear	1639 mm	64.5 in	1806 mm	71.2 in
16 Turning Radius from Center – Coupler	1314 mm	51.8 in	1401 mm	55.2 in
17 Turning Radius from Center – Bucket	2107 mm	83.0 in	2181 mm	85.9 in
18 Maximum Reach with Arms Parallel to Ground	1353 mm	53.3 in	1388 mm	54.6 in
19 Rack Back Angle at Maximum Height		91°		96°

*Operating Weight, Operating Specifications and Dimensions for the 236D and 246D all based on 75 kg (165 lb) operator, all fluids, one speed, OROPS, 1676 mm (66 in) dirt bucket, Cat 10 × 16.5 tires (on the 236D)/Cat 12 × 16.5 tires (on the 246D), standard flow hydraulics, mechanical suspension seat, no optional counterweights and manual quick coupler (unless otherwise noted).

232D Skid Steer Loaders Specifications

Dimensions*

All dimensions are approximate.

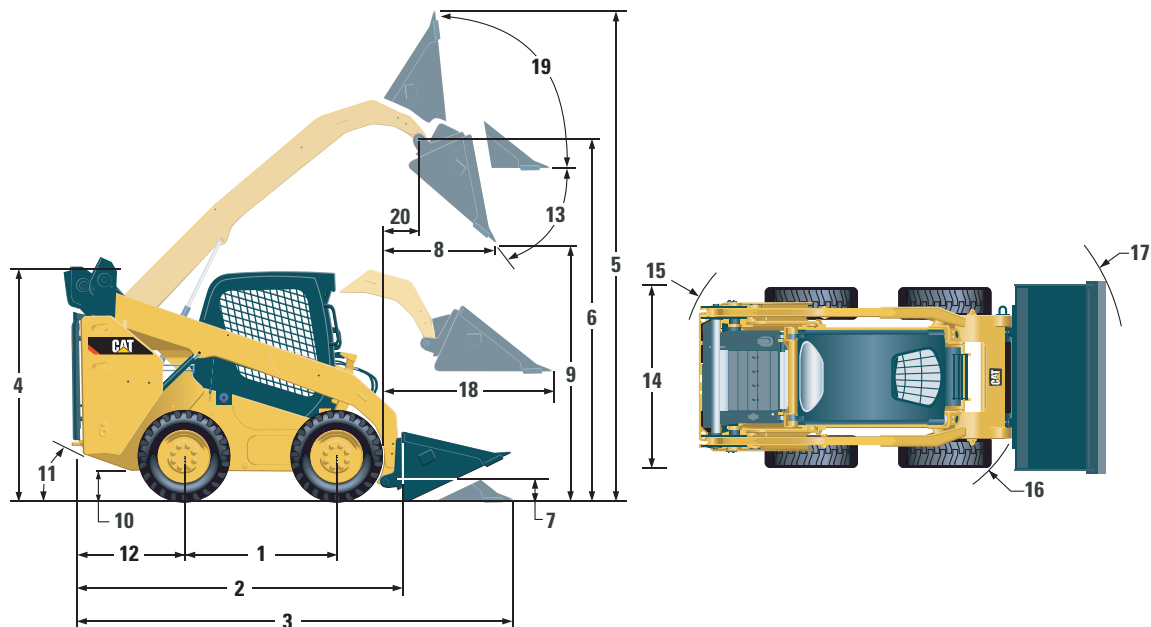

	232D	
1 Wheelbase	1054 mm	41.5 in
2 Length without Bucket	2523 mm	99.3 in
3 Length with Bucket on Ground	3233 mm	127.3 in
4 Height to Top of Cab	2029 mm	79.9 in
5 Maximum Overall Height	3832 mm	150.9 in
6 Bucket Pin Height at Maximum Lift	3001 mm	118.1 in
7 Bucket Pin Height at Carry Position	214 mm	8.4 in
8 Reach at Maximum Lift and Dump	653 mm	25.7 in
9 Clearance at Maximum Lift and Dump	2254 mm	88.7 in
10 Ground Clearance	170 mm	6.7 in
11 Departure Angle		27.9°
12 Bumper Overhang behind Rear Axle	894 mm	35.2 in
13 Maximum Dump Angle		47.4°
14 Vehicle Width over Tires	1497 mm	58.9 in
15 Turning Radius from Center - Machine Rear	1513 mm	59.6 in
16 Turning Radius from Center - Coupler	1102 mm	43.4 in
17 Turning Radius from Center - Bucket	1976 mm	77.8 in
18 Maximum Reach with Arms Parallel to Ground	1249 mm	49.2 in
19 Rack Back Angle at Maximum Height		88.2°
20 Bucket Pin Reach at Maximum Lift	224 mm	8.8 in

*Operating Weight, Operating Specifications and Dimensions all based on 75 kg (165 lb) operator, all fluids, single speed, 1524 mm (60 in) dirt bucket, Cat 10 × 16.5 tires, standard flow hydraulics, C0 cab (OROPS, static seat), 880 CCA battery, manual quick coupler, no self level and no optional counterweights (unless otherwise noted).

242D/262D Skid Steer Loaders Specifications

Dimensions*

All dimensions are approximate.

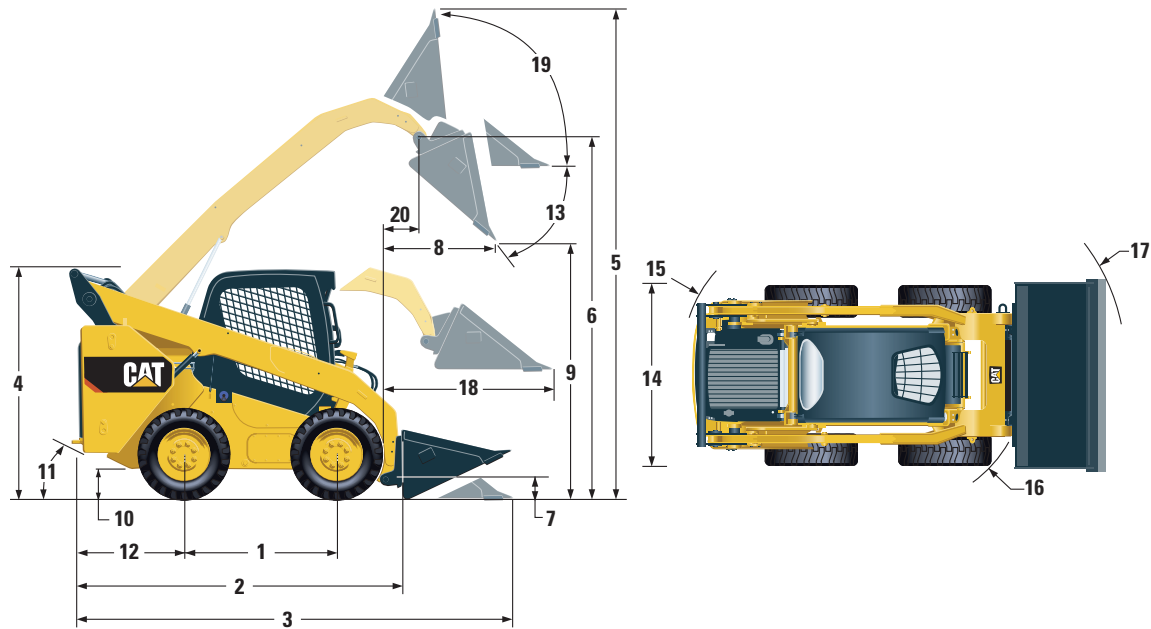

	242D		262D	
1 Wheelbase	1105 mm	43.5 in	1249 mm	49.2 in
2 Length without Bucket	2767 mm	108.9 in	2995 mm	117.9 in
3 Length with Bucket on Ground	3487 mm	137.3 in	3714 mm	146.2 in
4 Height to Top of Cab	2111 mm	83.1 in	2110 mm	83.1 in
5 Maximum Overall Height	3917 mm	154.2 in	4008 mm	157.8 in
6 Bucket Pin Height at Maximum Lift	3076 mm	121.1 in	3172 mm	124.9 in
7 Bucket Pin Height at Carry Position	200 mm	7.9 in	200 mm	7.9 in
8 Reach at Maximum Lift and Dump	552 mm	21.7 in	786 mm	30.9 in
9 Clearance at Maximum Lift and Dump	2285 mm	90.0 in	2380 mm	93.7 in
10 Ground Clearance	222 mm	8.7 in	226 mm	8.9 in
11 Departure Angle		27°		26°
12 Bumper Overhang behind Rear Axle	1021 mm	40.2 in	1083 mm	42.6 in
13 Maximum Dump Angle		52°		51°
14 Vehicle Width over Tires	1676 mm	66.0 in	1676 mm	66 in
15 Turning Radius from Center – Machine Rear	1639 mm	64.5 in	1805 mm	71.1 in
16 Turning Radius from Center – Coupler	1314 mm	51.8 in	1401 mm	55.2 in
17 Turning Radius from Center – Bucket	2107 mm	83.0 in	2181 mm	85.9 in
18 Maximum Reach with Arms Parallel to Ground	1249 mm	49.2 in	1293 mm	50.9 in
19 Rack Back Angle at Maximum Height		87°		84°
20 Bucket Pin Reach at Maximum Lift	182 mm	7.2 in	393 mm	15.5 in

*Operating Weight, Operating Specifications and Dimensions for the 242D and 262D all based on 75 kg (165 lb) operator, all fluids, one speed, OROPS, 1676 mm (66 in) dirt bucket, Cat 12 × 16.5 tires, standard flow hydraulics, mechanical suspension seat, no optional counterweights and manual quick coupler (unless otherwise noted).

226D/232D/236D/242D/246D/262D Standard Equipment

Standard Equipment

Standard equipment may vary. Consult your Cat dealer for details.

ELECTRICAL

- 12 volt Electrical System
- 80 ampere Alternator
- Ignition Key Start/Stop Switch
- Lights: Gauge Backlighting, Two Rear Tail Lights, Two Rear Halogen Working Lights, Two Adjustable Front Halogen Lights, Dome Light
- Backup Alarm
- Heavy Duty Battery, 880 CCA

OPERATOR ENVIRONMENT

- Gauges: Fuel Level, Hour Meter
- Operator Warning System Indicators: Air Filter Restriction, Alternator Output, Armrest Raised/Operator Out of Seat, Engine Coolant Temperature, Engine Oil Pressure, Glow Plug Activation, Hydraulic Filter Restriction, Hydraulic Oil Temperature, Park Brake Engaged, Engine Emission System
- Adjustable Vinyl Seat
- Fold In Ergonomic Contoured Armrest
- Control Interlock System, when operator leaves seat or armrest raised: Hydraulic System Disables, Hydrostatic Transmission Disables, Parking Brake Engages

- ROPS Cab, Open, Tilt Up
- FOPS, Level I
- Top and Rear Windows
- Floor Mat
- Interior Rearview Mirror
- 12 volt Electric Socket
- Horn
- Hand (Dial) Throttle, Electronic
- Adjustable Joystick Controls
- Anti-theft Security System with six-button Keypad
- Storage Compartment with Netting

POWER TRAIN

- Cat C2.2, Turbo Diesel Engine, Meets U.S. EPA Tier 4 Final (EU Stage IIIB) Emission Standards (226D/232D)
- Cat C3.3B, Turbo Diesel Engine, Meets U.S. EPA Tier 4 Final (EU Stage IIIB) Emission Standards (236D/242D/246D/262D)
- Air Cleaner, Dual Element, Radial Seal
- S·O·SSM Sampling Valve, Hydraulic Oil
- Filters, Cartridge-type, Hydraulic
- Filters, Cartridge-type, Fuel and Water Separator

- Radiator/Hydraulic Oil Cooler (side-by-side)
- Spring Applied, Hydraulically Released Parking Brakes
- Hydrostatic Transmission
- Four Wheel Chain Drive

OTHER

- Engine Enclosure, Lockable
- Extended Life Antifreeze, -36° C (-33° F)
- Machine Tie Down Points (6)
- Support, Lift Arm
- Hydraulic Oil Level Sight Gauge
- Radiator Coolant Level Sight Gauge
- Radiator, Expansion Bottle
- Cat ToughGuard™ Hose
- Auxiliary, Hydraulics, Continuous Flow
- Heavy Duty, Flat Faced Quick Disconnects with Integrated Pressure Release
- Split D-Ring to Route Work Tool Hoses Along Side of Left Lift Arm
- Electrical Outlet, Beacon
- Belly Pan Cleanout
- Variable Speed Demand Fan

226D/232D/236D/242D/246D/262D Mandatory Equipment

Mandatory Equipment

Mandatory equipment may vary. Consult your Cat dealer for details.

- Hydraulics, Standard Flow or High Flow (226D/232D/236D/242D)/High Flow XPS (246D/262D)
- Quick Coupler, Manual or Electric
- Seat Belt, 50 mm (2 in) or 75 mm (3 in)
- Power Train: One Speed, One Speed with Speed Sensitive Ride Control, Two Speed or Two Speed with Speed Sensitive Ride Control

COMFORT PACKAGES

- Open ROPS (C0): Static Seat, Foot Throttle (No Headliner, Heater or Door)
- Open ROPS (C1): Foot Throttle, Headliner, Cup Holder, and choice of Seat (Mechanical Suspension or High Back, Heated, Air Ride Seat) (No Heater or Door)
- Enclosed ROPS with Heater (C2): Foot Throttle, Headliner, Heater and Defroster, Side Windows, Cup Holder, Radio Ready, choice of Seat (Mechanical Suspension or High Back, Heated, Air Ride Seat) and Door (Glass or Polycarbonate)
- Enclosed ROPS with A/C (C3): C2 + Air Conditioner

PERFORMANCE PACKAGES FOR THE 226D/232D/236D/242D

- Performance Package H1: Standard Flow Hydraulics (No Self Level)
- Performance Package H2: Standard Flow Hydraulics, Dual Direction Electronic Self Level (Raise and Lower), Electronic Snubbing (Raise and Lower)
- Performance Package H3: High Flow Hydraulics, Dual Direction Electronic Self Level (Raise and Lower), Electronic Snubbing (Raise and Lower)

PERFORMANCE PACKAGES FOR THE 246D/262D

- Performance Package H1: Standard Flow Hydraulics (No Self Level)
- Performance Package H2: Standard Flow Hydraulics, Dual Direction Electronic Self Level (Raise and Lower), Electronic Snubbing (Raise and Lower)
- Performance Package H3: High Flow XPS, Dual Direction Electronic Self Level (Raise and Lower), Electronic Snubbing (Raise and Lower)

226D/232D/236D/242D/246D/262D Optional Equipment

Optional Equipment

Optional equipment may vary. Consult your Cat dealer for details.

- Hand-Foot Style Controls
- External Counterweights
- Beacon, Rotating
- Engine Block Heater – 120V
- Oil, Hydraulic, Cold Operation
- Paint, Custom
- Heavy Duty Battery, 1,000 CCA (246D/262D only)
- Product Link, Cellular
- Advanced Display: Full Color, 127 mm (5 in) LCD screen, Advanced Multi-operator Security System, On-screen Adjustments for Implement Response, Hystat Response, and Creep Control; Rearview Camera Ready
- Advanced Display: Rearview Camera Included
- Work Tool Return to Dig and Work Tool Positioner
- Bluetooth Radio with Microphone (AM/FM/Weather Band Receiver with USB and Auxiliary Input Jack)

For more complete information on Cat products, dealer services, and industry solutions, visit us on the web at www.cat.com

AEHQ7212-02 (04-2016)
Replaces AEHQ7212-01

© 2016 Caterpillar
All rights reserved

Materials and specifications are subject to change without notice. Featured machines in photos may include additional equipment. See your Cat dealer for available options.

CAT, CATERPILLAR, SAFETY.CAT.COM, their respective logos, "Caterpillar Yellow" and the "Power Edge" trade dress, as well as corporate and product identity used herein, are trademarks of Caterpillar and may not be used without permission.



Courtesy of Machine.Market