

232B/242B

Skid Steer Loaders



	232B		242B	
Engine	Cat [®] 3024C		Cat [®] 3024C T	
Engine Model	Cat [®] 3024C		Cat [®] 3024C T	
Net Flywheel Power	37 kW	49 hp	42 kW	57 hp
Gross Power	39 kW	52 hp	46 kW	62 hp
Weights	3021 kg 6661 lb		3085 kg 6802 lb	
Operating Weight	3021 kg	6661 lb	3085 kg	6802 lb
Operating Specifications	793 kg 1750 lb		907 kg 2000 lb	
Rated Operating Capacity	793 kg	1750 lb	907 kg	2000 lb

232B/242B Skid Steer Loaders

Designed, built and backed by Caterpillar® to deliver exceptional performance and versatility, ease of operation, serviceability and customer support.

Operator Station

Operator comfort and ease of operation are designed into the operator's station from every aspect including ergonomic features such as low-effort joystick controls and an adjustable contoured seat. **pg. 4**

High Performance Power Train

The Cat 3024C and 3024C Turbo engines provide high engine horsepower and torque, allowing part-throttle operation for lower sound levels and lower fuel consumption. Anti-stall feature maximizes power to the drive train and work tools without stalling the engine. **pg. 6**

Vertical Lift Linkage

The vertical lift linkage is an efficient and lightweight design that provides high load carry capacity. **pg. 7**

Customer Support

Caterpillar dealers offer unmatched customer support, with excellent warranty programs and fast parts availability, resulting in maximum uptime and minimum repair costs. Equipment maintenance services help optimize machine performance and reliability. **pg. 11**

The Caterpillar Skid Steer Loader, with its many work tool options, is a highly versatile, compact construction machine. It is designed to deliver traditional Cat reliability and productivity in the toughest conditions.



Advanced Hydraulic System

The hydraulic system in the Cat Skid Steer Loader is designed for maximum power and reliability. More hydraulic power means better overall performance. Fewer components mean fewer hydraulic connections and reduced chance of leaks. **pg. 8**

Quick Coupler and Cat Work Tools

A universal work tool interface and quick coupler help make the Cat Skid Steer Loader the most versatile machine on the job site. Add the wide range of performance-matched Cat Work Tools for maximum utility and production. **pg. 9**

Serviceability

The Cat Skid Steer Loader offers quick and easy routine maintenance and service. The rear door opens 90 degrees and the cooling package tilts up out of the way for unparalleled access to the engine compartment. The cab also tilts up for easy access. **pg. 10**



Operator Station

World-class operator station provides exceptional working comfort with excellent visibility, enhanced fingertip controls and optimum instrumentation.



Operator Station

Low Effort Machine Controls.

Ergonomic, pilot hydraulic controls give operators precision control of the Cat Skid Steer Loader with minimal effort. The right joystick controls loader up/down and tilt control and the left joystick controls forward and reverse travel speed plus direction. Both joysticks use an intuitive “S” control pattern. Optional deluxe joysticks now provide more auxiliary controls than before, using positive-action buttons to provide

precision fingertip control of many machine functions, including:

- Proportional work tool hydraulics
- Work tool electrical

Basic and Deluxe joystick functions include:

- One-touch continuous auxiliary hydraulic flow
- Momentary auxiliary hydraulic flow

Cab Conveniences. Long hours in the Cat Skid Steer Loader are made easier by many standard conveniences, including a 12 volt DC power socket. Side, sliding windows offer protection from the elements and allow fresh air ventilation. Redesigned side windows are removable for easy cleaning. Cabs with the door option installed feature a new, automatic lock-out switch that prevents accidental damage by disabling the loader functions when the door is open.

High-Efficiency Climate Controls.

Operating in extreme temperatures can be more comfortable with the optional cab air conditioner and heater installed. Airflow is increased up to 83 percent and is now directed through six adjustable vents. Twice as many vents makes defrosting the optional front door and side windows easier. The heater and air conditioner can be ordered separately or together.

Instrumentation. Cat Skid Steer Loader instrument panels and gauges are simple, easy to use and reliable. Bright indicator lights and audible warnings signal any critical system situation. Positive feel switches, with status lights, control most on/off functions. An engine air cleaner restriction indicator is now in the cab for easier monitoring.

Visibility. Operating ease and productivity is enhanced on the Cat Skid Steer Loader with excellent visibility. The wide cab opening offers an exceptional view of the work tool. The sloped angle of the engine compartment allows excellent visibility to the rear of the machine. A new, standard convex rearview mirror gives the operator a panoramic view of the machine's rear and sides. For better visibility in low-light conditions, the standard forward lights are now adjustable 10 degrees in any direction.

Access/Egress. The Cat Skid Steer Loader cab is designed to make machine operation simple, productive and comfortable. Getting in and out of the cab is easy through a wide opening with three point grab irons and skid-resistant steps. Tilt cylinders are neatly located under the lift arms so not to interfere with operator access and egress. Plenty of uncluttered floor space makes stepping into the cab even easier.

Cab Packages. Several cab packages and options are available. The standard cab offers features such as an adjustable contoured seat, cushioned contoured armbar, dual throttle controls, pilot operated joysticks, 12 volt DC power socket and an optional cup holder.



Excellent Visibility

High Performance Power Train

The Caterpillar hystat power train delivers aggressive performance and easy operation.



Powerful and Reliable

Cat Diesel Power. The heart of the Cat Skid Steer Loader power train is the Caterpillar 3024C diesel engine in the 232B and the Caterpillar 3024C Turbo diesel engine in the 242B. This rugged, reliable, four cylinder engine offers aggressive performance and a fast torque curve for quick response. It is also a low emission engine, fully U.S. EPA Tier 2 compliant.

Dual Engine Throttle Controls. The hand and foot throttles allow the operator to match engine speed to the task. The hand throttle is ideal for jobs requiring consistent engine speed — such as cold planing, trenching or snow blowing. The foot throttle lets the operator vary engine speed and minimizes fuel consumption for other tasks such as load and carry, truck loading, grading and dozing.

Anti-Stall Feature. The anti-stall system on the Cat Skid Steer Loader allows maximum power to the wheels while minimizing engine stalling. The system helps maximize productivity for experienced operators and makes it easier for novice operators to become productive.

Variable-Displacement Piston Pumps. The dual, variable-displacement, axial piston pumps are driven directly off the engine and provide hydraulic flow to the drive motors via a closed loop system. Drive motors transfer mechanical power to the wheels via two high-strength, pre-stressed chains per machine side. Chains run in an oil bath for constant lubrication and long life. Chains are adjustable through slots in the axle housings.

Drive Axles. The drive axles are forged and induction hardened for maximum life. They include a unique lip and outer seal to help prevent debris such as wire and twine from wrapping around the axle and destroying the seal. An inner seal is used for permanent lubrication of axle bearings so no daily axle service is required.

Vertical Lift Linkage

Designed and built for operation in the toughest working conditions requiring vertical lifting capabilities.

Lift Arms. The loader lift arms are purpose-designed to provide a substantially straight load path into the machine and a good viewing area to the work tool and side of the machine. The lift arms are also designed to handle heavy loads without twisting and bending for exceptional reliability.

Spherical Bearing. The spherical bearing distributes the load from the lift arm into the frame by allowing the pin to rotate and pivot within the bore, reducing the chance of developing fatigue cracks in the arms.

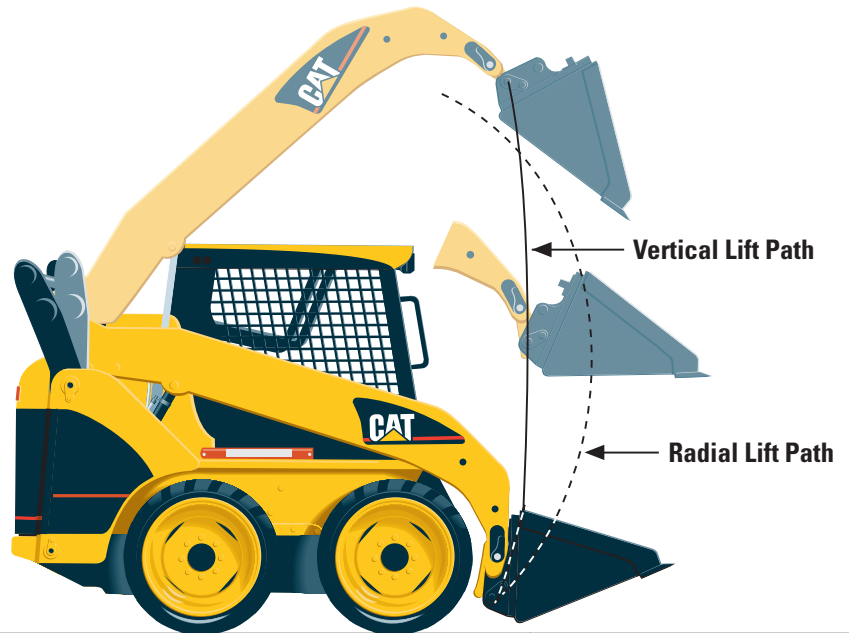

Vertical Lift



Advanced Hydraulic System

The hydraulic system has built-in reliability and provides exceptional lift, breakout and auxiliary power to work tools.



Powerful and Reliable

Power and Reliability. Maximum power and reliability are built into the Cat Skid Steer Loader hydraulic system. In addition to providing power to drive the wheels, this system also provides the loader lift and tilt functions, powers the auxiliary circuit to drive work tools and drives the engine cooling fan.

Hydraulic Pumps. The hydraulic pumps are driven directly off the engine for maximum hydraulic performance and reliability — no belts are used. Pumps are fixed-displacement and provide flow to the loader and auxiliary circuits at 60 L/min (15.6 gal/min) at high idle. Maximum system pressure for the loader and auxiliary circuit for the 232B is 21 400 kPa (3100 psi). Maximum system pressure for the loader and auxiliary circuit for the 242B is 23 000 kPa (3335 psi). Two fixed displacement gear pumps provide flow and pressure for the 242B high flow loader and auxiliary circuit at 100 L/min (26 gal/min) at high idle. Maximum system pressure for the loader and auxiliary circuit is 23 000 kPa (3335 psi). Control of the loader lift and tilt functions is by hydraulically-operated joystick controls for low effort and precise operation.

Auxiliary Hydraulics. Standard auxiliary hydraulics to power work tools is available through quick connect hydraulic couplings that are rigidly mounted to the loader arm. The Caterpillar line of high pressure XT™ ES hoses and O-ring face seals help assure a leak free system.

Reliability and Cleanliness. Hydraulic system reliability and cleanliness are improved by using single components in place of multiple components, such as the monoblock hydraulic valve and monoblock pumps. Fewer leak points improve reliability and result in a cleaner machine. In addition, hydraulic oil flows through a 5-micron spin-on filter. A filter restriction indicator is located in the operator station. A 74-micron screen in the hydraulic tank prevents larger debris from entering the system and causing damage to the hydraulic components.

Hydraulic Oil Cooler. A high-efficiency hydraulic oil cooler lets the Cat Skid Steer Loader work longer and harder in higher ambient temperatures, even when using continuous high flow work tools. The high capacity hydraulic oil reservoir also helps keep operating temperatures lower.

Quick Coupler and Cat Work Tools

Choose from a wide variety of tools that are performance-matched to the Cat Skid Steer Loader.



Optional Quick Coupler

Quick Coupler. Work tools can be changed quickly and easily with the Cat Skid Steer Loader's quick coupler system. The universal coupler interface features:

- Low profile side plate designed for optimum match to work tools and minimal material packing
- Opposing wedges ensure a tight tool fit, even after years of use
- Rugged design and large contact area absorbs loads and minimizes stress
- Vertical pins are chrome plated and lubricated for smooth engagement and prevention of corrosion
- Coupler allows excellent visibility to work tools and unobstructed entry and exit to the cab

The standard quick coupler features manual engagement and disengagement of work tools using two high leverage handles.

An optional hydraulic quick coupler is also available and allows engagement and disengagement of work tools without the operator needing to exit the machine. Control of the coupler by use of a rocker switch inside the cab makes work tool changes quicker and easier.



Cat SG16B Stump Grinder

Cat Work Tools. Cat Work Tools extend the versatility of the Cat Skid Steer Loader. Designed and built for optimum performance and durability, these tools deliver high productivity, long service life and excellent value:

- Angle Blades
- Augers
- Backhoes

- Brooms
- Brush cutters
- Buckets
 - Dirt
 - General purpose
 - Light material
 - Multi purpose
 - Utility
- Cold planers
- Compactor, vibratory
- Grapples and Forks
- Hammers
- Landscape rakes
- Landscape tillers
- Material handling arm
- Pallet forks
- Snowblower
- Stump grinder
- Trenchers
- Wheel saw

Serviceability

Quick access and superior design makes the Cat Skid Steer Loader easy to service and maintain.



Tilting Cab

Service Access. The rear door opens 90 degrees for easy access to both sides of the in-line (lengthwise) mounted engine.

Filters. All filters are easily accessible, which makes routine service quicker and virtually spill-free.

Cooling System. The radiator, hydraulic oil cooler and grill tilt up to increase access to the cooling system during maintenance and allow easier cleaning of debris from between the grill and cooling packages. The cooling fan is hydraulically-driven for quieter operation and to eliminate the service and maintenance that comes with belt driven fans.

Easy Tilting Cab. The machine cab can now be tilted rearward by an individual using a single tool. The cab is held in place by a self latching mechanism. When the cab is tilted back, all hydraulic pumps, motor, valves, lines and fuel tank are accessible for quicker, easier service.

Removable Belly Pan. A removable belly pan section on the floor of the machine's lower frame provides excellent access for periodic cleaning.

Electrical and Hydraulic Lines. Cleaner routing of electrical and hydraulic lines compared to former models improves reliability and simplifies service.

Maintenance Points. Maintenance points are grouped in easily accessible locations.

Caterpillar Scheduled Oil Sampling (S-O-SSM). The scheduled oil sampling valves are standard to allow regular monitoring of the engine and hydraulic oil quality.

Other Standard Service Features.

The following help make servicing fast and easy:

- Easy access to battery, air filter and single engine belt
- Sight glasses on hydraulic tank and radiator allow quick, easy level checks
- Air filter restriction indicator is now located inside the operator station
- Ecology drains simplify changing engine and hydraulic oil
- Grease fittings are countersunk to prevent damage
- Extended life coolant and 250-hour engine oil change intervals

Customer Support

Cat dealer services help you operate longer with lower costs.

Machine Selection. With 10 different Cat Skid Steer Loaders to choose from, selecting the right machine is even easier when you consult your Caterpillar dealer. Your dealer helps you make detailed machine comparisons before you purchase.

You can also build the machine that is right for you. Go on-line anytime to review the full range of features and options available using the Build and Quote application on your Cat dealer's website or www.cat.com.

Purchase Options. Purchase options let you look beyond just the initial machine price. With your Cat dealer, you can review available financing options plus look at day-to-day operating costs. You can also look at dealer services that can be included in the cost of the machine to yield lower equipment owning and operating costs over the life of the machine.

Customer Support Agreements.

Customer Support Agreements offer you a variety of service and maintenance options that can be customized to best fit your specific needs. These can cover the entire machine and included work tools to help protect your investment.

Machine Support. Machine support is one of your Cat dealer's primary goals. Nearly all parts are available at your Cat dealer. If not, your dealer can use the Caterpillar worldwide computer network to find the closest in-stock parts to minimize machine downtime. Your Cat dealer can also save you money by suggesting Cat Remanufactured parts that carry the same warranty as new but with savings of 40 to 70 percent.



Worldwide Parts Availability

Service Plans. Maintenance Service Plans help you manage machine maintenance. Choose from a wide range of maintenance plans and services at the time you purchase a machine. Repair option plans guarantee the cost of repairs up front. Diagnostics programs such as Scheduled Oil Sampling, Coolant Sampling and Technical Analysis help you avoid downtime and unscheduled repairs.

Training. Operator training by Cat dealers can improve your operator's techniques and help boost your profits. Your Cat dealer also has training video tapes, literature, application and equipment training courses, plus other ideas to help you maximize your machine investment.

Security Systems. Cat machine security systems help you manage your Cat Skid Steer Loader. This dealer-installed option provides control of machine access by untrained operators or unauthorized personnel. Use up to 50 unique key ID's to customize machine access to fit your needs. You can program this system to allow access only during certain hours or days.

Repair, Rebuild or Replace. The repair, rebuild or replace choices become even more evident when you consult your Caterpillar dealer. Your Cat dealer can help evaluate the costs involved so you can make the right decision every time.

Engine

Engine Model		
- 232B	Cat 3024C	
- 242B	Cat 3024C T	
Gross Power SAE J1995		
- 232B	39 kW	52 hp
- 242B	46 kW	62 hp
Engine Power ISO 14396		
- 232B	38 kW	51 hp
- 242B	46 kW	61 hp
Net Power 80/1269/EEC		
- 232B	37 kW	50 hp
- 242B	43 kW	57 hp
Net Power ISO 9249		
- 232B	37 kW	50 hp
- 242B	43 kW	57 hp
Net Power SAE 1349		
- 232B	37 kW	49 hp
- 242B	42 kW	57 hp
Displacement		
- 232B/242B	2.2 L	134 in ³
Stroke		
- 232B/242B	100 mm	3.9 in
Bore		
- 232B/242B	84 mm	3.3 in

Weights

Operating Weight		
- 232B	3021 kg	6661 lb
- 242B	3085 kg	6802 lb
Operating Weight (HF)		
- 242B	3127 kg	6895 lb

Operating Specifications

Rated Operating Capacity		
- 232B	793 kg	1750 lb
- 242B	907 kg	2000 lb
Rated Operating Capacity w/Optional Counterweight		
- 232B	815 kg	1795 lb
- 242B	928 kg	2047 lb
Tipping Load		
- 232B	1794 kg	3956 lb
- 242B	1814 kg	4000 lb
Breakout Force, Tilt Cylinder		
- 232B/242B	1841 kg	4059 lb
Breakout Force, Lift Cylinder		
- 232B/242B	1742 kg	3841 lb
Breakout Force, Lift Cylinder (HF)		
- 242B	1731 kg	3818 lb

Dimensions shown are based on standard machine equipped with optional 12 × 16.5 PR tires and 1676 mm (66 in) Dirt Bucket. The specifications for the Cat 232B/242B are static and conform to SAE J732 JUN 92, SAE J818 MAY87 and ISO 5998:1986.

Hydraulic System

Hydraulic Flow

- 232B/242B	Standard Flow
-------------	---------------

Hydraulic Flow

- 242B	High Flow
--------	-----------

Loader Hydraulic Pressure

- 232B	21 400 kPa	3100 psi
- 242B	23 000 kPa	3335 psi

Loader Hydraulic Flow

- 232B/242B	60 L/min	15.6 gal/min
-------------	----------	--------------

Loader Hydraulic Flow (HF)

- 242B	100 L/min	26 gal/min
--------	-----------	------------

Hydraulic Power

- 232B	21 kW	28.2 hp
- 242B	22.7 kW	30.4 hp

Hydraulic Power (HF)

- 242B	37.7 kW	50.6 hp
--------	---------	---------

Cab

ROPS

- 232B/242B	SAE J1040 MAY94 and ISO 3471:1994
-------------	--------------------------------------

FOPS

- 232B/242B	SAEJ/ISO 3449 APR98 Level I, ISO 3449:1992 Level I
-------------	--

FOPS Level II

- 232B/242B	SAEJ/ISO 3449 APR 98 Level II, ISO 3449:1992 Level II (optional)
-------------	--

Power Train

Travel Speed

- 232B	11.1 kph	6.9 mph
- 242B	12 kph	7.4 mph

Travel Speed Reverse

- 232B	11.1 kph	6.9 mph
- 242B	12 kph	7.4 mph

Service Refill Capacities

Chain box, each side

- 232B/242B	6 L	1.6 gal
-------------	-----	---------

Cooling System

- 232B/242B	10 L	2.6 gal
-------------	------	---------

Engine Crankcase

- 232B/242B	8 L	2.1 gal
-------------	-----	---------

Fuel Tank

- 232B/242B	65 L	17 gal
-------------	------	--------

Hydraulic System

- 232B/242B	55 L	14.5 gal
-------------	------	----------

Hydraulic Tank

- 232B/242B	35 L	9.2 gal
-------------	------	---------

Dimensions

All dimensions are approximate.

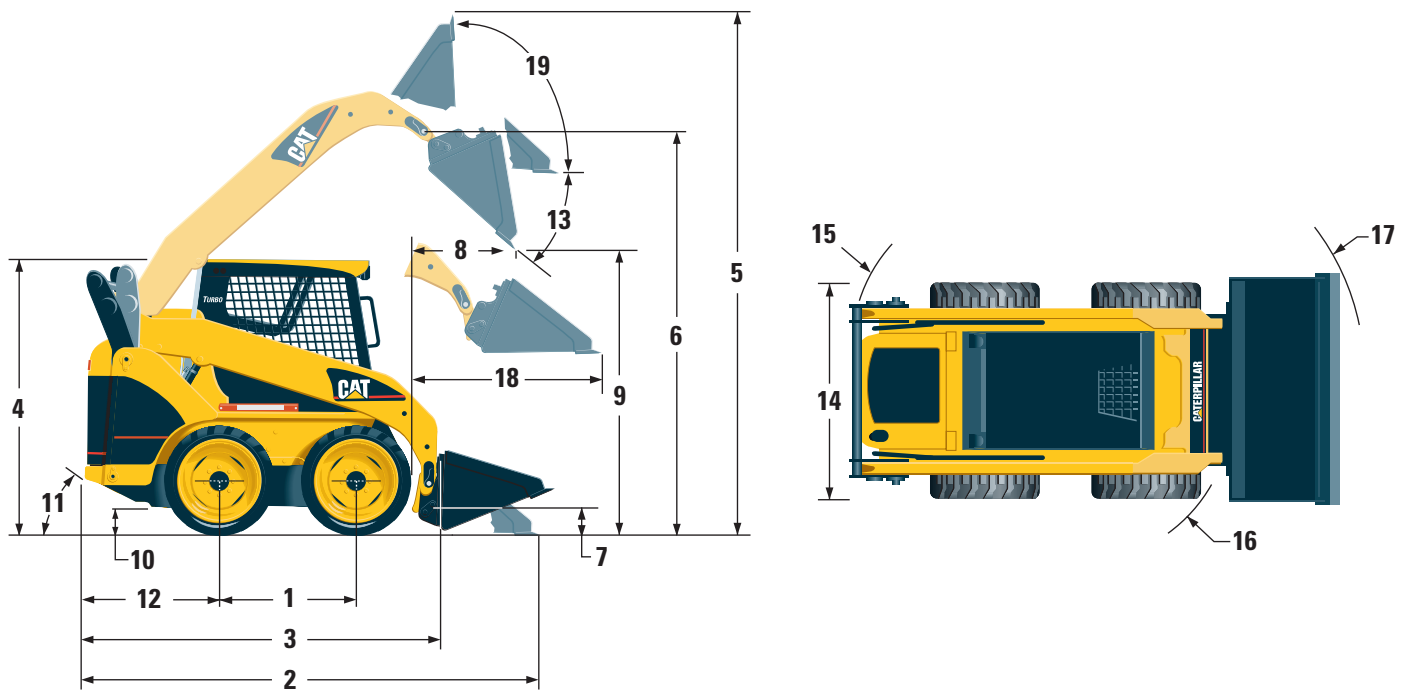

1	Wheelbase		
	- 232B/242B	1094 mm	43.1 in
2	Length w/Bucket on ground		
	- 232B/242B	3437 mm	135.3 in
3	Length w/o Bucket		
	- 232B/242B	2760 mm	108.7 in
4	Height to top of Cab		
	- 232B	1953 mm	77.0 in
	- 242B	1986 mm	78.0 in
5	Max Overall Height		
	- 232B	3894 mm	153.3 in
	- 242B	3926 mm	154.6 in
6	Hinge Pin Height at max lift		
	- 232B	3013 mm	118.6 in
	- 242B	3045.5 mm	119.9 in
7	Hinge Pin Height at carry position		
	- 232B	247 mm	9.7 in
	- 242B	299 mm	11.8 in
8	Reach at max lift and dump		
	- 232B/242B	766 mm	30.2 in
9	Clearance at max lift and dump		
	- 232B	2243 mm	88.3 in
	- 242B	2240 mm	88.0 in
10	Ground Clearance		
	- 232B	145 mm	5.7 in
	- 242B	178 mm	7.0 in

11	Departure Angle		
	- 232B/242B		28°
12	Bumper Overhang behind rear axle		
	- 232B/242B	989 mm	38.9 in
13	Maximum Dump Angle		
	- 232B/242B		50°
14	Vehicle Width over tires		
	- 232B	1524 mm	60.0 in
	- 242B	1676 mm	66.0 in
15	Turning Radius from center — left		
	- 232B/242B	1545 mm	60.8 in
16	Turning Radius from center — right		
	- 232B/242B	1409 mm	56.5 in
17	Turning Radius from center — full		
	- 232B/242B	2221 mm	87.4 in
18	Max Reach w/Arms Parallel to ground		
	- 232B/242B	1231 mm	48.4 in
19	Rack Back Angle at max height		
	- 232B/242B		86.9°

Standard Equipment

Standard equipment may vary. Consult your Caterpillar dealer for details.

CONTROLS

- Pilot Operated Implement Control, RH
- Pilot Operated Hydrostatic Transmission Control, LH
- Hand and Foot Throttle

ELECTRICAL

- 12 volt Electrical System
- 65 ampere Alternator (232B)
- 85 ampere Alternator (242B)
- Ignition Key Start/Stop Switch
- Lights:
 - Gauge Backlighting
 - Two Rear Tail Lights
 - Two Adjustable Front Halogen Lights
 - Dome Light

OPERATOR ENVIRONMENT

- Gauges:
 - Fuel Level
 - Hour Meter
- Operator Warning System Indicators:
 - Air Filter Restriction
 - Alternator Output
 - Armrest Raised/Operator Out of Seat
 - Engine Coolant Temperature
 - Engine Oil Pressure
 - Glow Plug Activation
 - Hydraulic Filter Restriction
 - Hydraulic Oil Temperature
 - Park Brake Engaged
- Adjustable Vinyl Seat
- Pull Down Ergonomic Contoured Armrest
- Control Interlock System, when operator leaves seat or armrest raised:
 - Hydraulic System Disables
 - Hydrostatic Transmission Disables
 - Parking Brake Engages
- ROPS Cab, Open, Tilt Up
- FOPS, Level I
- Top and Rear Windows
- Interior Rear View Mirror
- 12 volt Electric Socket

POWER TRAIN

- Caterpillar 3024C Diesel Engine (232B)
- Caterpillar 3024C T Diesel Engine (242B)
 - Drain, Engine Oil Ecology
 - Fuel Priming Pump
 - Glow Plugs Starting Aid
 - Liquid Cooled, Direct Injection
- Air Cleaner, Dual Element, Radial Seal
- S•O•SSM Sampling Valves, Engine Oil and Hydraulic Oil
- Filter, Spin-on, Hydraulic
- Filter, Bayonet-Type, Fuel and Water Separator
- Tilt Up Radiator/Hydraulic Oil Cooler
- Muffler, Standard
- Spring Applied, Hydraulically Released,
 - Wet Multi Disc Parking Brakes
- Hydrostatic Transmission
- Four Wheel Chain Drive

OTHER STANDARD EQUIPMENT

- Engine Enclosure — Lockable
- Extended Life Antifreeze -36° C (-33° F)
- Machine Tie Down Points (4)
- Coupler, Mechanical
- Support, Lift Arm
- Hydraulic Oil Level Sight Gauge
- Radiator Coolant Level Sight Gauge
- Radiator Expansion Bottle
- XTTM Hose
- Auxiliary, Hydraulics, Continuous Flow (High Flow)
- Heavy Duty, Flat Faced Quick Disconnects
- Split D-Ring to route Work Tool hoses along
 - side left lift arm
- Electrical Outlet, Beacon
- Belly Pan Cleanout

Optional Equipment

Optional equipment may vary. Consult your Caterpillar dealer for details.

Alarm, Backup	Oil, Hydraulic, Cold Climate
Battery, Heavy Duty, 880 CCA	Seat, Suspension
Belt, Seat, 75 mm (3 in), for Static Seat	Window, Side, Sliding
Belt, Seat, 75 mm (3 in), for Suspension Seat	Tires:
Control Groups	1524 mm (60 in) Width
Horn	10 × 16.5 8 PR Cat
Work Tool Electrical (C1/C2 Switch)	265-521, 8 PR Cat, LSW
Proportional	10 × 16.5 6 PR GY SGL
Counterweight, increases rated operating capacity 23 kg (50 lb)	10 × 16.5 8 PR GY IT323
Debris Barrier	8 × 16, Cat Solid (242B)
Door, Front, Safety Glass with Wiper-Washer	10 × 16.5 10 PR Michelin
Door, Front, Polycarbonate with Wiper-Washer (for Demolition use)	10 × 16.5 8 PR Galaxy
Floormat, Deluxe	1676 mm (66 in) Width
FOPS, Level II (Attaches to existing FOPS)	12 × 16.5 10 PR Cat, PF (242B)
Headliner	305-546, 10 PR Cat, LSW (242B)
Heater and Defroster	12 × 16.5 10 PR GY SGL (242B)
Air Conditioning, Heater, Defrost (242B)	12 × 16.5 10 PR GY IT323 (242B)
Engine, Coolant Heater	12 × 16.5 10 PR Galaxy (242B)
High Flow Hydraulics (242B)	33-15.5 × 16.5 12 PR Cat (242B)
Hydraulics, Auxiliary, Front, Proportional	10 × 16.5 6 PR GY SGL
Hydraulics, Self-Leveling	10 × 16.5 8 PR Galaxy
Hydraulic Quick Coupler	265-521, 8 PR Cat, LSW
Lifting Eye, Single Point	10 × 16.5 10 PR Michelin
Lifting Eyes, Four Point	
Lights, Warning Beacon (with Switch)	
Lights, Rear Working	

Notes

Notes

232B/242B Skid Steer Loaders

AEHQ5572-01 (10-05)

Replaces AEHQ5572

For more complete information on Cat products, dealer services,
and industry solutions, visit us on the web at www.cat.com

© 2005 Caterpillar
All Rights Reserved
Printed in U.S.A.

Materials and specifications are subject to change without notice.
Featured machines in photos may include additional equipment.
See your Caterpillar dealer for available options.

CAT, CATERPILLAR, their respective logos and "Caterpillar Yellow,"
as well as corporate and product identity used herein, are
trademarks of Caterpillar and may not be used without permission.

CATERPILLAR[®]