

302.4D

Mini Hydraulic Excavator



Engine

Gross Power (ISO 14396)	17.9 kW	24.3 hp
Net Power	13.2 kW	17.7 hp

Weights

Operating Weight with Cab	2320 kg	5,115 lb
Operating Weight with Canopy	2210 kg	4,872 lb

**Flexibility
and efficiency
to keep you
on track.**

**Dig with more
power and
save time
and effort
on the job.**

Contents

Versatility.....	4
Performance	5
Productive Comfort.....	6
Maintenance and Service	8
Specifications.....	10
Standard Equipment.....	12
Optional Equipment.....	12

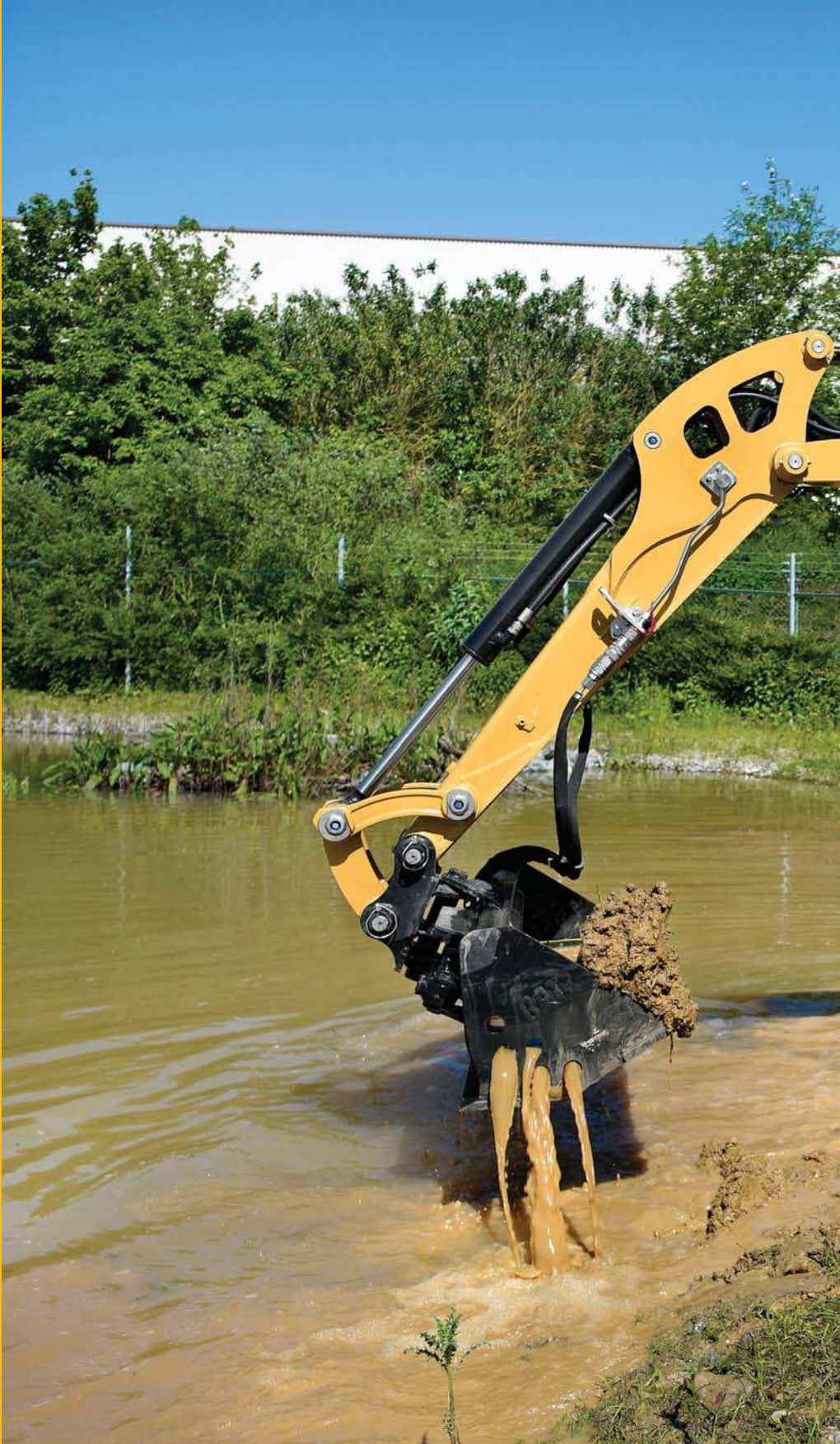



The Cat® 302.4D provides power and efficiency so that you can get the best out of your job without ever feeling the strain. You can be assured of faster, more powerful digging with a smoother response.

Versatility

Flexible and functional for all jobs.



High Flexibility

Compact in size and with a transport weight under 2300 kg (5,070 lb), the 302.4D can be transported easily using a conventional trailer and pick up truck or transit van.

The sturdy hoisting eyelets on the cab roof enable the easy and rapid relocation of the machine between sites.

Automatic Swing Lock

Safe transportation of the machine is aided by the Cat automatic swing lock which locks the machines upper body in place when the control console is raised or the engine is stopped.

Work Tools

A variety of purpose designed work tools are available, including buckets, quick couplers, hammer and auger. All Cat tools are built to last and matched to your machine to deliver excellent value and optimize performance.

Auxiliary Hydraulics as Standard Fit

Machine is 'ready to work.' Hammer and two way lines complete with quick disconnect fittings are standard. Connections are located close to the tool to reduce hose lengths and any potential damage. Additional line options are available to further increase machine versatility. Stick and bucket cylinder hoses are protected by routing them through the boom.

Auxiliary Flow Control

Machines configured with proportional auxiliary hydraulics, include the ability to adjust the flow for even greater tool control. Especially useful with tools such as angling ditching buckets.

Thumb Ready Stick (North American Builds)

The 302.4D is configured with brackets and relief valves for simple and cost effective mounting of a hydraulic thumb.



Performance

Powerful operation and greater uptime.

Built Tough

The front end of the 302.4D is designed for hard work. Its rugged construction and protected hydraulics ensure that the machine is up to the toughest of jobs. Steel tubes, positioned above the boom supply the hydraulic fluid to the tools, ensuring protection from damage while keeping any maintenance quick and easy.

Components have been located to ensure the best possible machine center of gravity and weight distribution and give operator confidence over a range of terrain and applications.



Dozer Float

Ground levelling and finishing applications are fast and easier with the dozer float function engaged making site clean-up much more efficient.

Dig Force

The 302.4D boasts high bucket and stick forces making it an impressive and productive excavator.

The choice of two stick lengths allows the customer to configure his machine to deliver even higher stick forces or longer reach. You have the choice, we have the solution.

All hydraulic functions are fully pilot operated, delivering effortless operation, reducing maintenance and lowering owner operating costs.



The Cat 302.4D cab is amongst the largest in the industry. The flat cab floor optimizes visibility and increases operator leg room. The ergonomic control layout provides a comfortable, highly productive workspace.

The large two-part front windscreen allows the driver to slide both lower and upper panes beneath the cab roof, so protecting them from damage when the front screen is wide open. This also negates the need to remove or store the bottom windscreen pane away separately.



100% Pilot Controls

All hydraulic functions are fully pilot operated, delivering effortless operation, reducing maintenance and lowering owner operating costs.

'As new' machine controllability is maintenance free without the need for adjustment of linkages or cables.

Auxiliary and boom swing services are controlled by proportional switches mounted on the joysticks.

2 Way Canopy Access

Canopy builds allow the operator to enter and exit the operator station from both sides of the machine, helping to increase productivity and making working around site much easier.



Productive Comfort

Large operator environment and ergonomic control layout.



Maintenance and Service

Easy access and minimal maintenance requirements keep you working.



Unmatched support makes the difference

Your Cat dealer is ready to assist you with your purchase decision and everything after.

- Financing packages are flexible to meet your needs
- Unmatched parts availability keeps you working
- Make comparisons of machines, with estimates of component life, preventative maintenance and cost of production
- For more information on Cat products, dealer services and industry solutions, visit www.cat.com



Easy Maintenance and Service

All daily checks and regular service points, are easily accessed.

A large steel rear door and removable panels allow room to efficiently work on the machine when required. The main hydraulic valve and lines are also easily reached through a removable floor plate and side panels.

Durable steel body panels all round the machine offer good resistance to damage and are easily maintained to help keep the machine looking good and holding its value.

Both side plates and the cab floor plate are easy to remove and provide unhindered access to all internal hydraulic components.



302.4D Mini Hydraulic Excavator Specifications

Engine

Engine Model	Yanmar 3TNV76	
Rated Net Power @ 2,200 rpm (ISO 9249)	13.2 kW	17.7 hp
Gross Power (ISO 14396)	17.9 kW	24.3 hp
Displacement	1116 cm ³	40 in ³

Weights

Transport Weight with Cab	2175 kg	4,795 lb
Transport Weight with Canopy	2065 kg	4,553 lb
Operating Weight with Cab	2320 kg	5,115 lb
Operating Weight with Canopy	2210 kg	4,872 lb

- Operating weight includes standard stick, rubber tracks, bucket, operator, full fuel.

Travel System

Travel Speed	2.5 km/h- 4 km/h	1.55 mph- 2.5 mph
Gradeability	30°/58%	

Service Refill Capacities

Fuel Tank Capacity	24 L	6.3 gal
Hydraulic Tank Capacity	19 L	5 gal

Operating Specifications

Stick Length – Standard	1050 mm	42 in
Stick Length – Long	1250 mm	49.2 in
Machine Overhang	460 mm	18.1 in

Blade

Width	1400 mm	55 in
Height	300 mm	11.8 in
Dig Depth	334 mm	13 in
Lift Height	294 mm	11.5 in

Hydraulic System

Pump Flow @ 2,200 rpm	26.1 + 26.1 + 19.4 + 6.4 L/min	6.9 + 6.9 + 5.1 + 1.7 gal/min
Operating Pressure – Equipment	240 bar	3,481 psi
Operating Pressure – Travel	240 bar	3,481 psi
Operating Pressure – Swing	150 bar	2,176 psi
Auxiliary Circuits		
Primary	30 L/min at 170 bar	8 gal/min at 2,465 psi
Secondary	17 L/min at 200 bar	4.5 gal/min at 2,900 psi
Maximum Bucket Force	21.8 kN	4,900 lbf
Maximum Stick Force – Standard Stick	15 kN	3,372 lbf
Maximum Stick Force – Long Stick	13.3 kN	2,990 lbf

Lift Capacity at Ground Level

Lift Point Radius	2 m (6'7")				2.5 m (8'2")				3 m (9'10")				Maximum			
	Front		Side		Front		Side		Front		Side		Front		Side	
	kg	lb	kg	lb	kg	lb	kg	lb	kg	lb	kg	lb	kg	lb	kg	lb
Standard Stick	1331*	2,934*	734	1,618	963*	2,123*	534	1,177	755*	1,665*	416	917	638*	1,407*	350	772
Long Stick	1315*	2,899*	729	1,607	943*	2,079*	530	1,168	740*	1,631*	411	906	584*	1,288*	317	699

*The above loads are in compliance with hydraulic excavator lift capacity rating standard ISO 10567:2007 and they do not exceed 87% of hydraulic lifting capacity or 75% of tipping capacity. The excavator bucket weight is not included on this chart.

302.4D Mini Hydraulic Excavator Specifications

Dimensions

All dimensions are approximate.

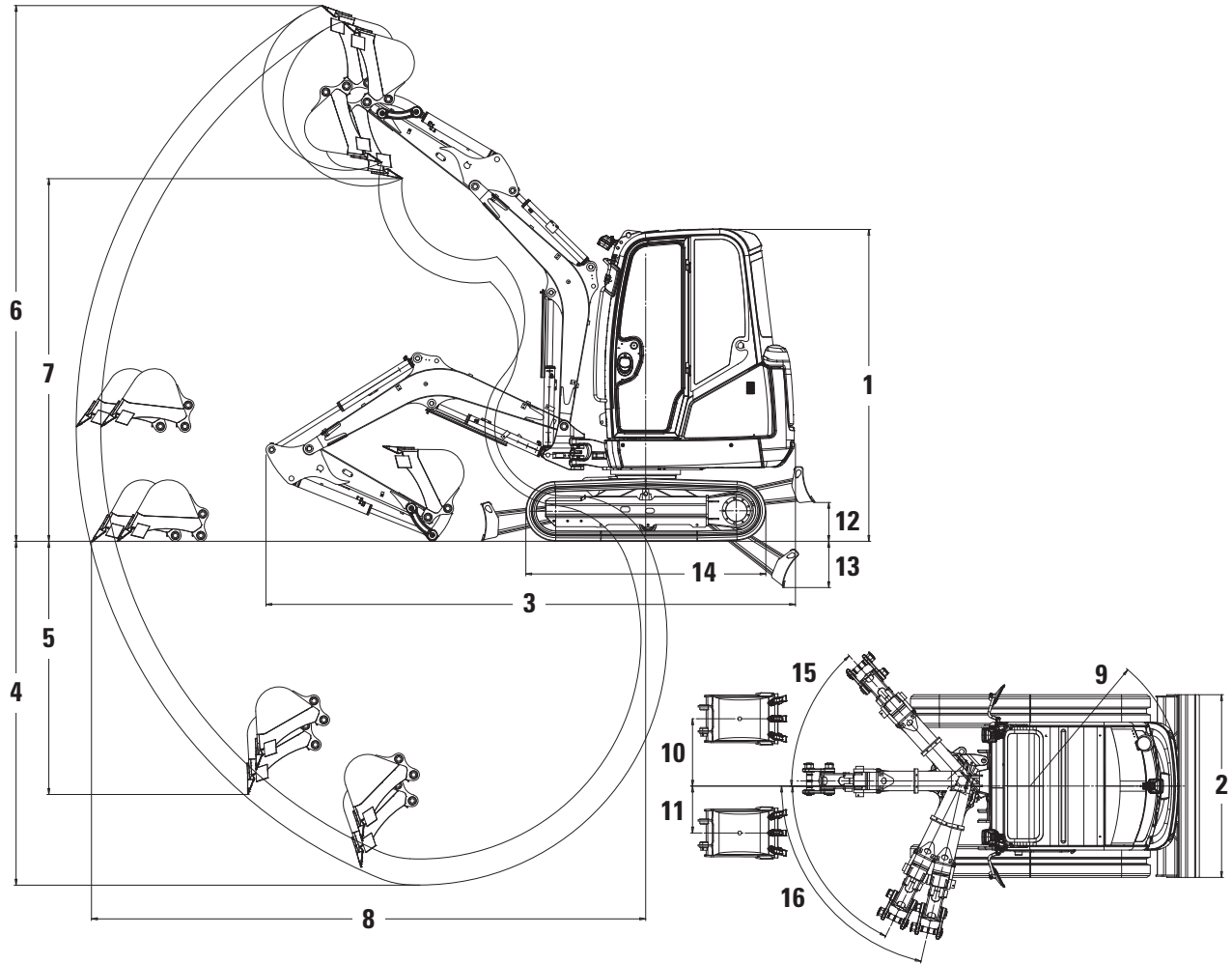

	Standard Stick		Long Stick	
1 Height	2390 mm	7'10"	2390 mm	7'10"
2 Width	1400 mm	4'6"	1400 mm	4'6"
3 Transport Length (arm lowered)	4030 mm	13'3"	4030 mm	13'3"
4 Maximum Digging Depth	2400 mm	7'11"	2600 mm	8'6"
5 Maximum Vertical Dig Depth	1570 mm	5'2"	1750 mm	5'9"
6 Maximum Dig Height	3950 mm	12'11"	4070 mm	13'4"
7 Maximum Dump Height	2750 mm	9'0"	2870 mm	9'5"
8 Maximum Reach at Ground Level	4020 mm	13'2"	4220 mm	13'10"
9 Tail Swing Radius	1170 mm	3'10"	1170 mm	3'10"
10 Maximum Boom Offset (RH)	520 mm	20"	520 mm	20"
11 Maximum Boom Offset (LH)	360 mm	14"	360 mm	14"
12 Maximum Dozer Lift Height	300 mm	12"	300 mm	12"
13 Maximum Dozer Dig Depth	335 mm	13"	335 mm	13"
14 Length of Undercarriage	1840 mm	6'0"	1840 mm	6'0"
15 Boom Swing Angle (RH)	48°		48°	
16 Boom Swing Angle (LH)	77°/64°		77°/64°	

302.4D Standard Equipment

Standard Equipment

Standard equipment may vary. Consult your Cat dealer for details.

- Automatic swing park brake
- Auxiliary quick disconnect couplers
- Canopy – ROPS and TOPS protection
- Dozer blade
- Dozer float
- Fixed undercarriage
- Hammer/two way auxiliary hydraulic lines
- Hydraulic oil cooler
- Maintenance free battery
- Retractable seat belt
- Rubber track 250 mm (10 in) wide
- Suspension seat, vinyl covered
- Travel pedals
- Working light mounted to boom

302.4D Optional Equipment

Optional Equipment

Optional equipment may vary. Consult your Cat dealer for details.

- Additional hydraulic circuit diverted from bucket cylinder
- Auto engine idle
- Boom stick or dozer blade check valve
- Cab, radio ready – ROPS and TOPS protection, heater/defroster and windscreen washer/wiper
- Cab top guard to ISO 10262 (Level 1)
- Cab/canopy lights
- Joystick mounted proportional auxiliary control with flow control
- Long stick
- Mirror pack
- Removable swing stop
- Second auxiliary lines
- Suspension seat, fabric covered

For more complete information on Cat products, dealer services, and industry solutions, visit us on the web at www.cat.com

© 2014 Caterpillar
All rights reserved

Materials and specifications are subject to change without notice. Featured machines in photos may include additional equipment. See your Cat dealer for available options.

CAT, CATERPILLAR, SAFETY.CAT.COM, their respective logos, "Caterpillar Yellow" and the "Power Edge" trade dress, as well as corporate and product identity used herein, are trademarks of Caterpillar and may not be used without permission.

AEHQ6854-02 (06-2014)
Replaces AEHQ6854-01



Courtesy of Machine.Market