



# 321D LCR

Hydraulic Excavator



#### Cat® C6.4 Engine with ACERT™ Technology

Net Power (ISO 9249) at 1800 rpm	103 kW/140 hp
Operating Weight	24 000 to 25 500 kg
Maximum Travel Speed	5.5 km/h
Maximum Reach at Ground Level	10 110 mm
Maximum Digging Depth	6680 mm
Tail Swing Radius	1680 mm

# 321D LCR Hydraulic Excavator

*Offers a compact radius and improved performance, versatility and styling.*

---

## Compact Radius

The 321D LCR is a “Compact Radius” machine developed so that it can work in the narrow job-site. The cylindrical upper frame and cylindrical operator station, allow the 321D LCR to rotate in the narrower job-sites. **pg. 4**

---

## C6.4 Engine with ACERT™ Technology

✓ ACERT™ Technology works at the point of combustion to optimize engine performance and provide low exhaust emissions to meet EU Stage IIIA emission regulations, with exceptional performance capabilities and proven reliability. **pg. 5**

---

## Operator Comfort

✓ Provides maximum space, wider visibility and easy access to switches. The monitor is a full-color graphical display that allows the operator to understand the machine information easily. Overall, the new cab provides a comfortable environment for the operator. **pg. 8**

---

## Hydraulics

The hydraulic system has been designed to provide reliability and outstanding controllability. An optional Tool Control System provides enhanced flexibility. **pg. 6**

---

## Versatility

Caterpillar offers a wide variety of factory-installed attachments that enhance performance and job site management. **pg. 12**

*The Caterpillar 321D LCR excavator provides all the elements to give you the lowest cost to own and operate. At the end of the day, it all comes down to how much work you got done and how much did it cost you. Caterpillar and the 321D LCR offer you the tools to help lower your owning and operating costs.*



✓ *New Feature*

---

### Booms, Stick and Linkage

- ✓ One Reach boom and one VA boom related to one long stick (R2.9B1) are available to suit a variety of application conditions. **pg. 10**

---

### Structures

Caterpillar® design and manufacturing techniques assure outstanding durability and service life from these important components. **pg. 7**

---

### Work Tools

Caterpillar buckets, multi-processors, sorting and demolition grapples, hammers and quick couplers provide a total solution package to the end-user. **pg. 11**

---

### Service and Maintenance

- ✓ Fast, easy service has been designed in with extended service intervals, advanced filtration, convenient filter access and user-friendly electronic diagnostics for increased productivity and reduced maintenance costs. **pg. 13**

---

### Complete Customer Support

Your Cat® dealer offers a wide range of services that can be set up under a customer support agreement when you purchase your equipment. The dealer will help you choose a plan that can cover everything from machine configuration to eventual replacement. **pg. 13**



# Compact Radius

The 321D LCR delivers exceptional performance and comfort.



**Compact Radius.** The 321D LCR features a compact radius design, which makes it ideal for working in space restricted areas such as: close to buildings, road construction – limiting lane closures or logging roads. The tail swing is just 1680 mm as compared to the 2750 mm on the 320D. When rotated 90 degrees and working over the side, a minimal amount of counterweight extends beyond the track width.

**Operator Confidence.** Due to the 321D LCR’s compact working envelope, operators can work confidently knowing that the counterweight will not swing into any object behind them.

**Comfort.** The cab on the 321D LCR is a comfortable place to work, with low sound levels, good visibility and convenient access to switches and controls.

**Working Envelope.** To further minimize the working envelope, the boom is repositioning more towards the center of the machine as compared to a standard excavator. This reduced the front swing radius when the boom is pulled all the way up and the stick brought in completely. This design also increases the lift capacity of the 321D LCR over the front as it has a better mechanical advantage when compared to a standard excavator.

### 321D LCR versus 320D LRR and 320D L

Compare minimum front swing radius and tail swing radius:

	321D LCR	320D LRR	320D L
Tail swing radius (mm)	1676	2000	2750
Minimum front swing radius (mm)	2340	3660	3660
Overhang (mm)			
with 600 mm shoes	186	510	1235
with 800 mm shoes	86	410	1110

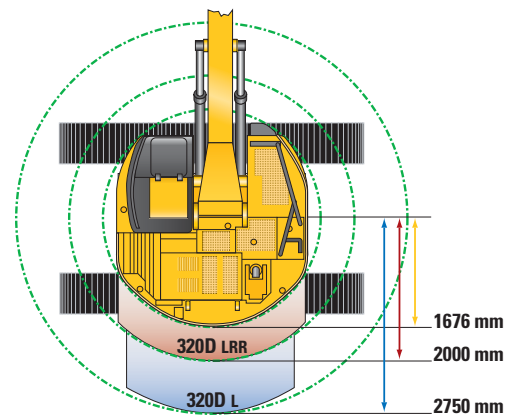

## Engine

*The Cat® C6.4 gives the 321D LCR exceptional power and fuel efficiency unmatched in the industry for consistently high performance in all applications.*



**Cat C6.4.** The Cat C6.4 with ACERT Technology introduces a series of evolutionary, incremental improvements that provide breakthrough engine technology. The building blocks of ACERT Technology are fuel delivery, air management and electronic control. ACERT Technology optimizes engine performance while meeting EU Stage IIIA emission regulations. With its proven technology, robust components and precision manufacturing, you can count on this engine to power up at start time and keep working productively all shift long.

**Performance.** The 321D LCR, equipped with the C6.4 engine with ACERT Technology, provides 7% more power as compared to the 3066 TA in the 321C LCR. The additional power delivers a speed and efficiency advantage in high production applications.

### **Automatic Engine Speed Control.**

The two-stage, one-touch control maximizes fuel efficiency and reduces sound levels.



### **ADEM™ A4 Engine Controller.**

The ADEM A4 electronic control module manages fuel delivery to get the best performance per liter of fuel used. The engine management system provides flexible fuel mapping, allowing the engine to respond quickly to varying application needs. It tracks engine and machine conditions while keeping the engine operating at peak efficiency.

### **Electronic Control Module.**

The Electronic Control Module (ECM) works as the “brain” of the engine’s control system, responding quickly to operating variables to maximize engine efficiency. Fully integrated with sensors in the engine’s fuel, air, coolant, and exhaust systems, the ECM stores and relays information on conditions such as rpm, fuel consumption, and diagnostic information.

**Fuel Delivery.** The Cat C6.4 features electronic controls that govern the fuel injection system. Multiple injection fuel delivery involves a high degree of precision. Precisely shaping the combustion cycle lowers combustion chamber temperatures, generating fewer emissions and optimizing fuel combustion. This translates into more work output for your fuel cost.

**Cooling System.** The cooling fan is directly driven from the engine. An electrically controlled viscous clutch fan is available as an attachment to reduce fan noise. The optimum fan speed is calculated based on the target engine speed, coolant temperature, hydraulic oil temperature and actual fan speed. When fan speed is reduced, there’s more power available for other functions – and less fuel is burned.

## Hydraulics

*Cat® hydraulics deliver power and precise control to keep material moving.*



**Component Layout.** To optimize efficiency of hydraulic performance, the hydraulic components are located close together, which reduces friction loss and pressure drops in the lines.

**System Pressure.** System pressure has been increased to 350 bar, which attributes to improved performance:

- Increased stick and bucket forces (up 7% higher than the 321C LCR) to better handle those tight digging conditions
- More drawbar pull (206 kN) to provide more ability to climb slopes, easier spot turns and improved travel in poor underfoot conditions
- More lift capacity, generally over the front where you are generally hydraulically limited

**Heavy Lift.** The 321D LCR features the addition of a heavy lift, which increases system pressure to 360 bar, giving even more lift capacity over the front. Heavy Lift is activated by depressing the soft switch on the right hand console. As the pressure increases, the engine speed is reduced, which allows better control while lifting objects.

**Pilot System.** The pilot pump is independent from the main pumps and controls the front linkage, swing and travel operations.

**Hydraulic Cross Sensing System.**

The hydraulic cross sensing system utilizes each of two hydraulic pumps to 100 percent of engine power, under all operating conditions. This improves productivity with faster implement speeds and quicker, stronger pivot turns.

**Boom and Stick Regeneration Circuit.**

Boom and stick regeneration circuit saves energy during boom-down and stick-in operation which increases efficiency, reduces cycle times and pressure loss for higher productivity, lower operating costs and increased fuel efficiency.

**Auxiliary Hydraulic Valve.** The auxiliary valve is standard on the 321D LCR.

Control Circuits are available as attachments, allowing for operation of high and medium pressure tools such as shears, grapples, hammers, pulverizers, multi-processors and vibratory plate compactors.

**Hydraulic Cylinder Snubbers.**

Snubbers are located at the rod-end of the boom cylinders and both ends of the stick cylinder to cushion shocks while reducing sound levels and extending component life.

## Structures

*321D LCR is designed to handle the most rugged operating conditions, while providing long life and value.*

**Robust Undercarriage.** A solid foundation built tough to absorb the stresses of everyday work.

- Rollers and idlers are sealed and lubricated to extend service life.
- Track links are assembled and sealed with grease to decrease internal bushing wear and increase life by as much as 25%, when compared to dry seal undercarriages.
- Spring recoil system stroke has been increased to better relieve excess track tension, which can occur when material builds up between the track and sprocket.

**Rugged Structures.** Structural components and the undercarriage are the backbone of the machine's durability. Caterpillar places a lot of emphasis on the machine's durability during the designing and manufacturing of its excavators.

- Up to 95% of the structural welds are welded by robots, which achieve up to three times the penetration of a manual weld and improving overall durability of the machine.
- The 321D LCR's main frame utilizes high-tensile strength steel and a one-piece swing table, which improves strength and reliability.
- The carbody has a X-shaped, box section design to resist bending and twisting forces.
- Track roller frames are press-formed in a pentagonal shape for additional strength.



**Engine Hood.** The 321D LCR features a one-piece, flat engine hood. The engine hood opens backwards and is located in a place that does not obstruct access to inspection points in the engine compartment.

**Counterweight.** The counterweight is split into two pieces for improved serviceability. The top piece weighs approximately 2270 kg, and the bottom weighs 3830 kg. The counterweight is a rounded cast structure that minimizes the amount of overhang.

## Operator Comfort

*Caterpillar offers the most intuitive and easy to operate excavators while providing great all around visibility and exceptional operator comfort.*

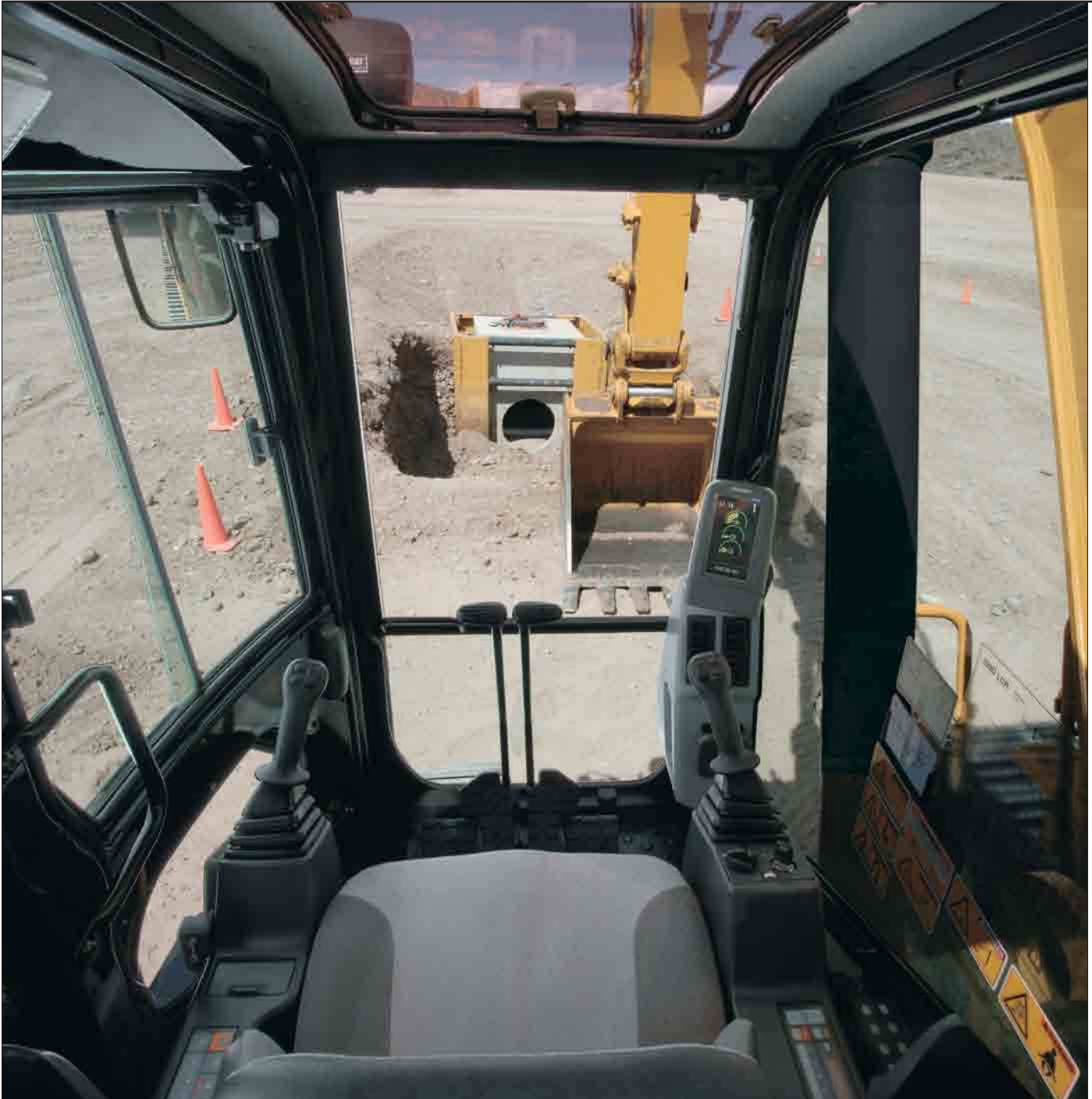



**Operator Station.** The layout of the interior has been redesigned to maximize operator comfort and reduce operator fatigue.

- Frequently used switches have been relocated for easier access.
- Consoles and armrests have been redesigned for better comfort and adjustability.
- More seat options – choose from the standard mechanical suspension seat, or the optional air suspension seat with heater. Both provide excellent comfort.

**Standard Cab Equipment.** To enhance operator comfort and productivity, the cab includes a lighter, drink holder, coat hook, service meter, literature holder, magazine rack and storage compartment.

**Joystick Control.** Joystick controls have low lever effort and are designed to match the operator’s natural wrist and arm position.

**Hydraulic Activation Control Lever.** For added safety, this lever must be in the operate position to activate the machine control functions.

**Climate Control.** Climate control adjusts temperature and flow, and determines which air outlet is best in each situation with a touch of a button.

**Cab Exterior.** The cab is made of pressed-steel plates. The pillars, beams and crossbeam, are formed box-shape, which improves the resistance of fatigue and vibration.

**Hand Control Pattern Changer (Optional).** Switches the joystick pattern between ISO and SAE patterns. For easy access, the pattern changer is located in the cab, underneath the floor mat. In order to change positions, simply remove the bolt, slide the lever into the appropriate location, then secure the bolt.

**Sliding Door.** The cab door slides alongside the cab and takes less space to open and close than a hinged door. This unique design allows the operator to easily get in and out of the cab when working next to objects or walls.

**Skylight.** An enlarged skylight with sunshade provides excellent visibility and ventilation.



**Monitor.** The monitor is a full color Liquid Crystal Display that gives you vital operating and performance information, alerts in text, all in a simple, easy to navigate format.

**Default Display.** Three analog gauges, fuel level, hydraulic oil temperature and coolant temperature, are displayed in this area.

**Main Menu.** Four menu options to choose from:

- Settings – Adjust monitor settings, select work tool or choose video mode (when equipped with a camera).
- Maintenance – Displays service intervals and hours accumulated since last serviced.
- Performance – Displays machine performance attributes such as Engine Speed, Coolant and Hydraulic Oil Temperature.
- Service – Allows access to machine parameters for service intervals, diagnostic information and information related to the machines software.

**Event Display.** Machine information is displayed in this area with the icon and language.

**Multi-information Display.** This area is reserved for displaying various information which is convenient for the operator. The “CAT” logo is displayed when no information is available to be displayed.

## Booms, Stick and Bucket Linkage

*Built for performance and long service life, Caterpillar® booms and sticks are large, welded, box-section structures with thick, multi-plate fabrications in high stress areas.*



**Front Linkage Attachments.** Select the right combination of front linkage with your Cat dealer to ensure high productivity from the very start of your job. Two types of booms and one stick are available. All booms and sticks undergo a stress relieving process for greater durability.

**Reach Boom.** The reach boom is designed to balance reach, digging force bucket capacity, offering a wide range of applications as digging, loading, trenching and working with hydraulic tools.

**Variable Adjustable Boom.** It offers superb flexibility and versatility in the working envelope. Boom position can be adjusted from 90° when fully retracted to 165° when fully extended. With full extension, the working range gives both maximum dig depth, reach and working height. Equally, when the VA boom is retracted, it can work closer to its tracks, increase lifting capacity and work in confined areas.

**Bucket Linkage.** The power link improves durability, increases machine-lifting capability in key lifting positions and with the integrated lift-eye it is easier to use than compared to the previous power link. The lift eye also gives you the optimum lift performance. It allows you to lower the load point, which maximizes the use of the boom cylinders.

**Stick Construction.** Sticks are made of high-tensile strength steel using a large box section design with interior baffle plates and an additional bottom guard to protect against damage.

### **R2.9B1 Stick**

- The 2920 mm stick with reach boom gives the largest working envelope with medium-sized buckets.
- The 2920 mm stick with VA boom provides the necessary strength in digging, lifting and hammering applications.

## Work Tools

*A wide variety of Work Tools help optimize machine performance. Purpose designed and built to Caterpillar's high durability standards.*

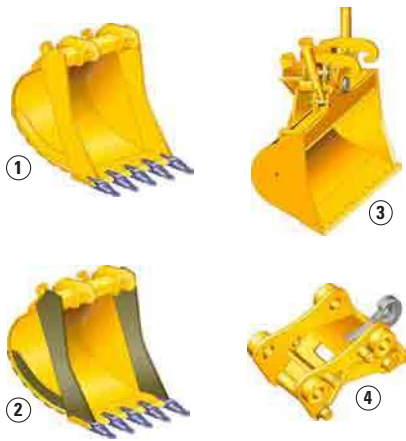

- 1 Excavation (X)
- 2 Extreme Excavation (EX)
- 3 Ditch Cleaning
- 4 Quick Coupler



**Work Tools.** Caterpillar work tools are designed to function as an integral part of your excavator and to provide the best possible performance in your particular application. All work tools are performance-matched to Cat machines.

**Quick Couplers.** Quick couplers enable the operator to simply release one work tool and connect to another, making your hydraulic excavator highly versatile. Productivity also increases, as a carrier no longer needs to be idle between jobs. Caterpillar offers hydraulic and spindle quick coupler versions.

**Buckets.** Caterpillar offers a wide range of specialized buckets, each designed and tested to function as an integral part of your excavator. Buckets feature the new Caterpillar K Series™ Ground Engaging Tools.

**Hammers.** Cat hammer series deliver very high blow rates, increasing the productivity of your tool carriers in demolition and construction applications. Wide oil flow acceptance ranges make the Caterpillar hammers suitable for a wide range of carriers and provide a system solution from one safe source.

**Orange Peel Grapples.** The orange peel grapple is constructed of high-strength, wear-resistant steel, with a low and compact design that makes it ideal for dump clearance. There are several choices of tine and shell versions.

**Multi-Grapples.** The multi-grapple with unlimited left and right rotation is the ideal tool for stripping, sorting, handling and loading. The powerful closing force of the grab shells combined with fast opening/closing time ensures rapid cycle time which translates to more tons per hour.

**Multi-Processors.** Thanks to its single basic housing design, the multi-processor series of hydraulic demolition equipment makes it possible to use a range of jaw sets that can handle any demolition job. The multi-processor is the most versatile demolition tool on the market.

**Vibratory Plate Compactors.** Cat compactors are performance-matched to Cat machines, and integrate perfectly with the Cat hammer line – brackets and hydraulic kits are fully interchangeable between hammers and compactors.

**Shears.** Cat shears provide superior and effective scrap processing, and are highly productive in demolition environments. Shears are compatible with a matching Cat excavator, and bolt-on brackets are available for either stick or boom-mounted options.

## Versatility

*A wide variety of optional factory-installed attachments are available to enhance performance and improve job site management.*



### Auxiliary Hydraulic Options.

Allows you to configure your 321D LCR to meet your work tools needs, while increasing its versatility.

- Single Function Circuit – suited for tools that require one-way flow with both pumps, such as hammers, vibratory plate compactors.
- Double Function Circuit – suited for tools that require two-way flow, utilizing one pump, such as thumbs or non-rotation grapples or shears.
- Tool Control System
  - Accommodates single or double function tools, as well as rotating tools when equipped with medium pressure.
  - Stores pressure and flow information for up to 10 tools
  - Cat tools selectable that have preset flows and pressures
  - Shortcut button on right hand console, making tool selection easier.

**Machine Security.** An optional Machine Security System is available from the factory on the 321D LCR. This system controls when the machine can be operated and utilizes specific keys to prevent unauthorized machine use, a significant theft deterrent.

**Product Link.** Both the PL121 and PL321 are available as factory installed attachments.

PL121 gives you Asset Watch, which includes the following features:

- Engine hours
- Machine location
- Time based fences (when the machines can operate)
- Geo-based fences (boundaries that the machine can operate)

PL321 gives you all of the features listed for PL121, plus the ability to include Health and Maintenance Watch:

- Health Watch
  - Codes from on-board EDM's/Sensors
  - Estimated Fuel Consumption
  - Fuel Watch
- Maintenance Watch
  - Preventative Maintenance Planning
  - Preventative Maintenance Checklists
  - Overdue PM Notification
  - PM History Recording

**More Attachments.** The 321D LCR offers the most options available to equip your machine to best match your application and work environment requirements. From track shoe size to guarding packages to operator comfort options, the 321D LCR offers more options.

## Service and Maintenance

*Simplified service and maintenance save you time and money.*



**Extended Service Intervals.** 321D LCR service and maintenance intervals have been extended to reduce machine service time and increase machine availability.

**Air Filter Compartment.** The air filter features a double-element construction for superior cleaning efficiency. When the air cleaner plugs, a warning is displayed on the monitor screen inside the cab.

**Ground Level Service.** The design and layout of the 321D was made with the service technician in mind. Many service locations are easily accessible at ground level allowing critical maintenance to get done quickly and efficiently.

**Pump Compartment.** A service door on the right side of the upper structure allows ground-level access to the pump and pilot filter.

**Capsule Filter.** The hydraulic return filter, a capsule filter, is situated outside the hydraulic tank. This filter prevents contaminants from entering the system when hydraulic oil is changed and keeps the operation clean.

**Diagnostics and Monitoring.** The 321D is equipped with S•O•S<sup>SM</sup> sampling ports and hydraulic test ports for the hydraulic system, engine oil, and for coolant.

A test connection for the Electronic Technician (ET) service tool is located behind the cab.

**Anti-Skid Plate.** Anti-skid plate covers top of storage box and upper structure to prevent slipping during maintenance.

**Fan Guard.** Engine radiator fan is completely enclosed by fine wire mesh, reducing the risk of an accident.

**Greasing Points.** A concentrated remote greasing block on the boom delivers grease to hard-to-reach locations on the front.

**Radiator Compartment.** The left rear service door allows easy access to the engine radiator, oil cooler and air-to-air aftercooler. Reserve tank and drain cock are attached to the radiator for simplified maintenance.

## Complete Customer Support

*Cat dealer services help you operate longer with lower costs.*

**Machine Selection.** Make detailed comparisons of the machines you are considering before you buy. What are the job requirements, machine attachments and operating hours? What production is needed? Your Cat dealer can provide recommendations.

**Purchase.** Consider the financing options available as well as day-to-day operating costs. This is also the time to look at dealer services that can be included in the cost of the machine to yield lower equipment owning and operating costs over the long run.

### Customer Support Agreements.

Cat dealers offer a variety of product support agreements, and work with customers to develop a plan the best meets specific needs. These plans can cover the entire machine, including attachments, to help protect the customer's investment.

**Operation.** Improving operating techniques can boost your profits. Your cat dealer has videotapes, literature and other ideas to help you increase productivity, and Caterpillar offers certified operator training classes to help maximize the return on your investment.

**Product Support.** You will find nearly all parts at our dealer parts counter. Cat dealers utilize a worldwide computer network to find in-stock parts to minimize machine downtime. You can save money with Cat remanufactured components.

**Maintenance Services.** Repair option programs guarantee the cost of repairs up front. Diagnostic programs such as Scheduled Oil Sampling, Coolant Sampling and Technical Analysis help you avoid unscheduled repairs.

**Replacement.** Repair, rebuild or replace? Your Cat dealer can help you evaluate the cost involved so you can make the right choice.

## Engine

Cat C6.4 Engine with ACERT Technology

Net Power at 1800 rpm

ISO 9249	103 kW/140 hp
----------	---------------

80/1269/EEC	103 kW/140 hp
-------------	---------------

Bore	102 mm
------	--------

Stroke	130 mm
--------	--------

Displacement	6.4 L
--------------	-------

- All engine horsepower (hp) are metric including front page.
- The C6.4 engine meets EU Stage IIIA emission requirements.
- Net power advertised is the power available at the flywheel when the engine is equipped with fan, air cleaner, muffler, and alternator.
- Full engine net power up to 2300 m altitude (engine derating required above 2300 m).

## Drive

Maximum Travel Speed	5.5 km/h
----------------------	----------

Maximum Drawbar Pull	206 kN
----------------------	--------

## Swing Mechanism

Swing Speed	11.5 rpm
-------------	----------

Swing Torque	62 kNm
--------------	--------

## Sound

The dynamic exterior sound power level meets EU Directive 2005/88/EC.

## Cab/FOGS

Cab/FOGS meets ISO 10262.

## Hydraulic System

Main System

Maximum flow	2 x 205 L/min
--------------	---------------

Maximum pressure

Normal	350 bar
--------	---------

Heavy	360 bar
-------	---------

Travel	350 bar
--------	---------

Swing	250 bar
-------	---------

Pilot System

Maximum flow	32 L/min
--------------	----------

Maximum pressure	39 bar
------------------	--------

Boom Cylinders

Bore	120 mm
------	--------

Stroke	1260 mm
--------	---------

Stick Cylinder

Bore	140 mm
------	--------

Stroke	1518 mm
--------	---------

B1 Family Bucket Cylinder

Bore	120 mm
------	--------

Stroke	1104 mm
--------	---------

## Machine and Major Component Weights

Actual weights and ground pressures will depend on final machine configuration.

		Reach boom	VA boom
Stick type		<b>R2.9B1</b>	<b>R2.9B1</b>
Stick length	mm	2920	2920
Bucket weight	kg	784	700
Bucket capacity	m <sup>3</sup>	1.1	0.9
Bucket width/type	mm	1200/X	1000/X
Operating weight*			
600 mm shoes	kg	23 970	24 830
800 mm shoes	kg	24 640	25 490
Ground pressure			
600 mm shoes	bar	0.53	0.55
800 mm shoes	bar	0.41	0.42
Stick weight (with bucket cylinder)	kg	690	690
Boom weight (with stick cylinder)	kg	1380	2210
Upperstructure (without counterweight)	kg	6540	
Undercarriage			
600 mm shoes	kg	7190	
800 mm shoes	kg	7860	
Counterweight	kg	6100	

\* With counterweight, quick coupler, bucket, operator and full fuel.

## Service Refill Capacities

	Liters
Fuel Tank	410
Cooling System	25
Diesel Engine	30
Swing Drive (each)	8
Final Drive (each)	8
Hydraulic system (including tank)	260
Hydraulic tank	120

## Track Shoes

Triple grouser	600, 700, 800 mm
----------------	------------------

# Dimensions

All dimensions are approximate.

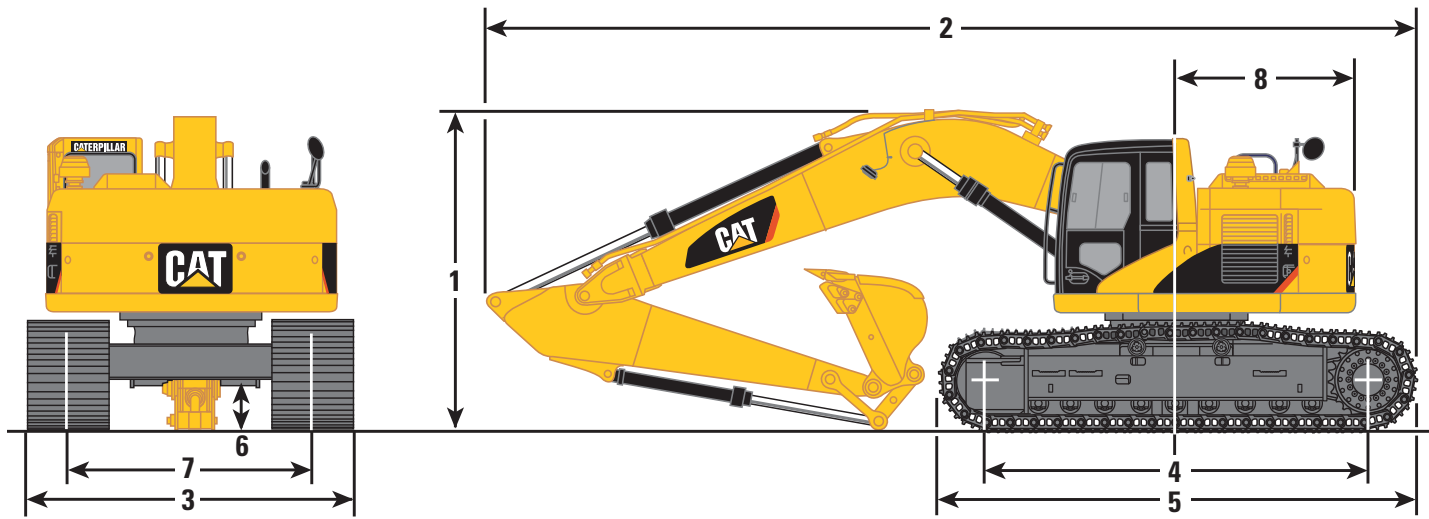

	mm		mm		mm
<b>1</b> Shipping height (with bucket)		<b>2</b> Shipping length		<b>3</b> Transport width	
Reach Boom		Reach Boom		600 mm shoes	2980
2920 mm stick	3170	2920 mm stick	8900	800 mm shoes	3180
VA Boom		VA Boom		<b>4</b> Length to centers of rollers	3650
2920 mm stick	3170	2920 mm stick	9200	<b>5</b> Track length	4455
				<b>6</b> Ground clearance	450
				<b>7</b> Track gauge	2380
				<b>8</b> Tail swing radius	1676
				Cab height	2980

# Bucket Specifications

Contact your Caterpillar dealer for special bucket requirements. All buckets are available to fit the Cat quick coupler.

Bucket type	Linkage	Width mm	Capacity (ISO) m <sup>3</sup>	Weight* kg	Reach boom 5680 mm			
					Pin-on		Quick coupler	
					Weight* kg	R2.9B1 (2920 mm)	Weight* kg	R2.9B1 (2920 mm)
Excavation (X)	B1	544	0.44	601		544		
	B1	585	0.59	593		585		
	B1	662	0.86	698		662		
	B1	475	1.08	784		475		
	B1	765	1.13	801		765		
	B1	783	1.19	819		783		
	B1	818	1.3	854		818		
Extreme Excavation (EX)	B1	853	1.41	889		853		
	B1	615	0.59	620		615		
	B1	791	1.13	827		791		
	B1	828	1.18	864		828		
	B1	865	1.3	901		865		
Maximum load in kg (payload plus bucket)						3134		2651

\* Including tips

Max. Material density  
1200 kg/m<sup>3</sup>

Max. Material density  
1500 kg/m<sup>3</sup>

Material density  
1800 kg/m<sup>3</sup> and more

## Working Range – Reach Boom (5680 mm)

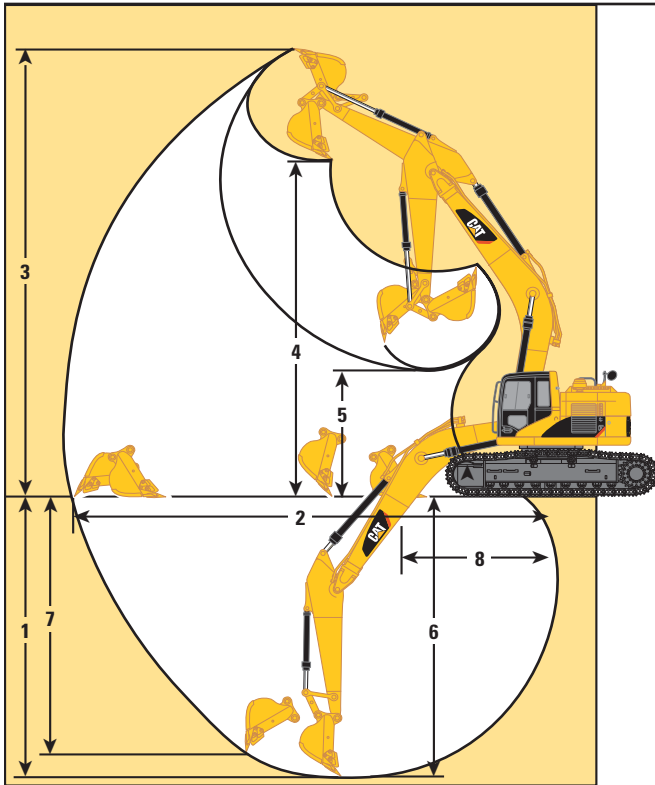

Stick Type	<b>R2.9B1</b>
Stick Length	2920 mm
<b>1</b> Maximum Digging Depth	6680 mm
<b>2</b> Maximum Reach at Ground Level	9750 mm
<b>3</b> Maximum Cutting Height	10 990 mm
<b>4</b> Maximum Loading Height	7920 mm
<b>5</b> Minimum Loading Height	3000 mm
<b>6</b> Maximum Digging Depth 2.5 m Level Bottom	6500 mm
<b>7</b> Maximum Vertical Wall Digging Depth	6170 mm
<b>8</b> Minimum Front Swing Radius	2340 mm
Bucket Tip Radius	1554 mm
Bucket Forces (ISO 6015)	141 kN
Stick Forces (ISO 6015)	106 kN

## Working Ranges – Variable Adjustable Boom (5940 mm)

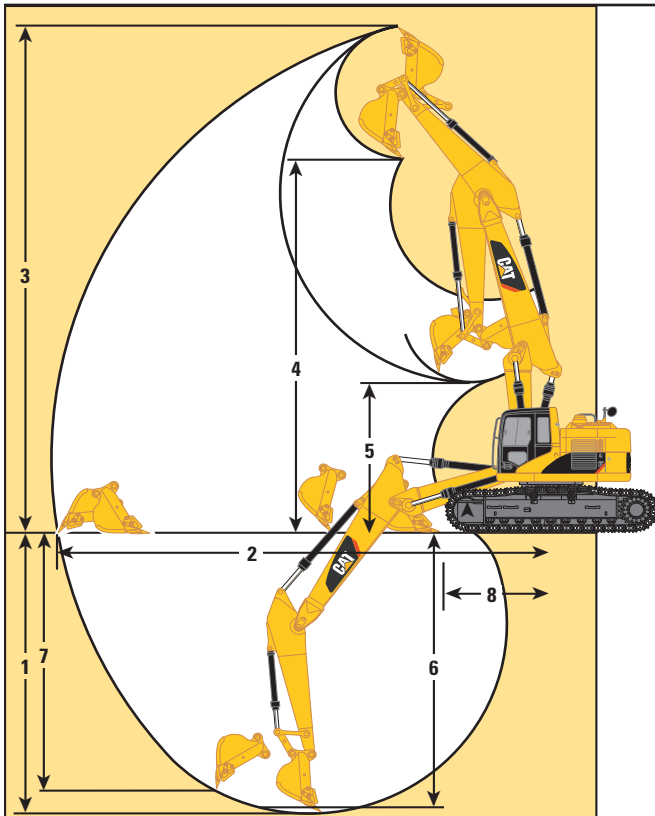

















Stick Type	<b>R2.9B1</b>
Stick Length	2920 mm
<b>1</b> Maximum Digging Depth	6490 mm
<b>2</b> Maximum Reach at Ground Level	10 110 mm
<b>3</b> Maximum Cutting Height	11 630 mm
<b>4</b> Maximum Loading Height	8580 mm
<b>5</b> Minimum Loading Height	3440 mm
<b>6</b> Maximum Digging Depth 2.5 m Level Bottom	6400 mm
<b>7</b> Maximum Vertical Wall Digging Depth	5770 mm
<b>8</b> Minimum Front Swing Radius	2340 mm
Bucket Tip Radius	1554 mm
Bucket Forces (ISO 6015)	141 kN
Stick Forces (ISO 6015)	106 kN



















# Lift Capacities – Reach Boom (5680 mm)

All weights are in kg, without bucket, with quick coupler, heavy lift on.

















**Stick**  
2920 mm  
**Shoes**  
600 mm

	1.5 m		3.0 m		4.5 m		6.0 m		7.5 m		9.0 m				m	
																
9.0 m					*5100	*5100								3800*	3800	5.08
7.5 m							*4950	*4950						3250*	3250	6.71
6.0 m					*5550	*5550	*5450	5050	*3950	3450				3050*	3050	7.73
4.5 m			*7900	*7900	*6950	*6950	*6100	4900	5550	3400				3000	2800	8.35
3.0 m			*14100	13700	*9000	7150	*7100	4650	5400	3300				3100	2550	8.67
1.5 m			*5900	*5900	*10900	6650	7450	4400	5250	3150				3300	2500	8.72
0 m			*7450	*7450	11500	6350	7250	4200	5150	3050				3700	2550	8.51
-1.5 m	*6850	*6850	*11200	*11200	11350	6250	7150	4100	5100	3000				4350	2750	8.02
-3.0 m	*11050	*11050	*15650	12250	*11050	6250	7150	4150						5500	3250	7.18
-4.5 m			*12350	*12350	*8850	6450								6250	4450	5.85

**Stick**  
2920 mm  
**Shoes**  
700 mm

	1.5 m		3.0 m		4.5 m		6.0 m		7.5 m		9.0 m				m	
																
9.0 m					*5100	*5100								*3800	*3800	5.08
7.5 m							*4950	*4950						*3250	*3250	6.71
6.0 m					*5550	*5550	*5450	5150	*3950	3500				*3050	*3050	7.73
4.5 m			*7900	*7900	*6950	*6950	*6100	4950	5600	3450				*3000	2850	8.35
3.0 m			*14100	13950	*9000	7300	*7100	4700	5500	3350				*3100	2600	8.67
1.5 m			*5900	*5900	*10900	6750	7550	4450	5350	3200				*3300	2550	8.72
0 m			*7450	*7450	11700	6450	7350	4300	5250	3100				*3700	2600	8.51
-1.5 m	*6850	*6850	*11200	*11200	11550	6350	7250	4200	5200	3100				*4350	2800	8.02
-3.0 m	*11050	*11050	*15650	12450	*11050	6400	7250	4200						5600	3300	7.18
-4.5 m			*12350	*12350	*8850	6550								*6250	4550	5.85

**Stick**  
2920 mm  
**Shoes**  
800 mm

	1.5 m		3.0 m		4.5 m		6.0 m		7.5 m		9.0 m				m	
																
9.0 m					*5100	*5100								*3800	*3800	5.08
7.5 m							*4950	*4950						*3250	*3250	6.71
6.0 m					*5550	*5550	*5450	5200	*3950	3550				*3050	*3050	7.73
4.5 m			*7900	*7900	*6950	*6950	*6100	5000	*5700	3500				*3000	2900	8.35
3.0 m			*14100	14100	*9000	7350	*7100	4750	5550	3400				*3100	2650	8.67
1.5 m			*5900	*5900	*10900	6850	7650	4500	5450	3250				*3300	2600	8.72
0 m			*7450	*7450	11850	6550	7450	4350	5350	3150				*3700	2650	8.51
-1.5 m	*6850	*6850	*11200	*11200	11700	6450	7350	4250	5300	3100				*4350	2850	8.02
-3.0 m	*11050	*11050	*15650	12600	*11050	6450	7350	4250						*5650	3350	7.18
-4.5 m			*12350	*12350	*8850	6650								*6250	4600	5.85



Load Point Height



Load Radius Over Front



Load Radius Over Side



Load at Maximum Reach

















\* Limited by hydraulic rather than tipping load.

The above loads are in compliance with hydraulic excavator lift capacity ratings standard ISO 10567, they do not exceed 87% of hydraulic lifting capacity or 75% of tipping capacity. Weight of all lifting accessories must be deducted from the above lifting capacities.

















# Lift Capacities – VA Boom (5940 mm)

All weights are in kg, without bucket, with quick coupler, heavy lift on.

**Stick**  
2920 mm  
**Shoes**  
600 mm

	1.5 m		3.0 m		4.5 m		6.0 m		7.5 m		9.0 m					
															m	
9.0 m					*5700	*5700								*3750	*3750	5.67
7.5 m					*5550	*5550	*5450	5050						*3200	*3200	7.17
6.0 m					*5750	*5750	*6000	5000	*5000	3350				*3000	2850	8.12
4.5 m			*8800	*8800	*7950	7600	*6800	4750	*4450	3250				*2950	2450	8.72
3.0 m					*9750	6900	*7350	4450	*4150	3100	*3200	2250	*3000	2250	9.03	
1.5 m					*10500	6300	7250	4150	*4450	2950	*3750	2200	*3150	2150	9.08	
0 m			*5200	*5200	*10250	5950	7000	3950	5000	2850			*3450	2200	8.88	
-1.5 m			*8950	*8950	*9100	5850	6900	3850	4950	2800			*4000	2400	8.40	
-3.0 m					*7050	5900	*5450	3850	*3500	2850			*3300	2800	7.61	
-4.5 m			*14550	12550	*8500	6300							*4600	4300	5.76	

**Stick**  
2920 mm  
**Shoes**  
800 mm

	1.5 m		3.0 m		4.5 m		6.0 m		7.5 m		9.0 m					
															m	
9.0 m					*5700	*5700								*3750	*3750	5.67
7.5 m					*5550	*5550	*5450	*5200						*3200	*3200	7.17
6.0 m					*5750	*5750	*6000	5100	*5000	3450				*3000	2950	8.12
4.5 m			*8800	*8800	*7950	7800	*6800	4900	*4450	3350				*2950	2550	8.72
3.0 m					*9750	7100	*7350	4600	*4150	3200	*3200	2350	*3000	2300	9.03	
1.5 m					*10500	6500	7450	4300	*4450	3050	*3750	2300	*3150	2250	9.08	
0 m			*5200	*5200	*10250	6150	7250	4050	5150	2950			*3450	2300	8.88	
-1.5 m			*8950	*8950	*9100	6050	*6900	3950	5100	2900			*4000	2500	8.40	
-3.0 m					*7050	6100	*5450	4000	*3500	2950			*3300	2900	7.61	
-4.5 m			*14550	12950	*8500	6500							*4600	4450	5.76	



Load Point Height



Load Radius Over Front



Load Radius Over Side



Load at Maximum Reach

\* Limited by hydraulic rather than tipping load.

The above loads are in compliance with hydraulic excavator lift capacity ratings standard ISO 10567, they do not exceed 87% of hydraulic lifting capacity or 75% of tipping capacity. Weight of all lifting accessories must be deducted from the above lifting capacities.

## Standard Equipment

Standard equipment may vary. Consult your Caterpillar dealer for specifics.

### Electrical

Alternator, 50 A  
Base machine light (frame)  
Electric start, 24 volt  
Horn  
Pre-start monitoring system – checks for low fluids (engine oil, coolant, hydraulic oil) prior to starting machine

### Operator Environment

Air conditioner, heater, defroster with automatic climate control  
Ashtray with 24 volt lighter  
Beverage/cup holder  
Bolt-on Falling Object Guarding System (FOGS) capability  
Cab Glass  
    Openable and retractable two-piece front windshield  
    Skylight, pop-up  
Coat hook  
Floor mat  
Instrument panel and gauges  
Joysticks, console mounted, pilot operated  
Light, interior  
Literature compartment  
Monitor, full graphic color display  
Neutral lever (lock out) for all controls

Positive filtered ventilation  
Pressurized cab  
Seat, suspension, with high back and head rest  
Seat belt, retractable – 75 mm  
Storage compartment suitable for lunch box cooler  
Sun shade (for skylight)  
Travel control pedals with removable hand levers  
Tempered glass windows  
Windshield wiper and washer (upper and lower)

### Engine/Power Train

C6.4 with ACERT™ Technology  
Air intake heater  
Air-to-air aftercooler (ATAAC)  
HEUI™ injectors  
2300 m altitude capability without derate  
Automatic engine speed control with one touch low idle  
Cooling  
    Protection of 43°C to –18°C at 50% concentration  
Straight line travel  
Two-speed auto-shift travel  
Water separator in fuel line

### Undercarriage

Grease lubricated track  
Hydraulic track adjusters  
Idler and center section track guards  
Long undercarriage

### Other Standard Equipment

Automatic swing parking brake  
Auxiliary hydraulic valve  
Capability of stackable valves (max of 3) for main valve  
Capability of auxiliary circuit  
Counterweight with lifting eyes  
Door locks, cap locks and Caterpillar® one key security system  
Fine swing control  
Fully pressurized hydraulic system  
Heavy lift  
Mirrors (frame-right, cab left)  
S•O•S quick sampling valves for engine and hydraulic oil  
Wave fin radiator  
Wiring provision for Product Link

## Optional Equipment

Optional equipment may vary. Consult your Caterpillar dealer for specifics.

### Front Linkage

Booms  
    Reach 5680 mm  
    VA 5940 mm  
Stick  
    Reach 2920 mm  
Bucket Linkage  
    B1 Family  
Boom Lowering Control Device  
Stick Lowering Control Device

### Electrical

Light, Boom – Right side  
Lights, Cab mounted (2)  
Machine Security System (MSS)  
Power supply (12 V/5 A)  
Product Link  
Travel Alarm

### Guarding

Falling Object Guarding System (FOGS)  
Front windshield guard  
Full length, wire mesh

Heavy-duty bottom guards  
Track guiding guards  
    Sprocket end, idler end guard  
    Two-piece full length (center guard removed)

### Operator Environment

AM/FM Radio with antenna and 2 speakers  
Rear window, secondary exit  
Seat, high back with air suspension and heater

### Engine/Power Train

Starting, Cold weather package  
Two additional maintenance free batteries  
High capacity starter motor  
Heavy-duty cable  
Water level indicator (fuel)

### Undercarriage

Track shoes triple grouser  
    600, 700, 800 mm  
Heavy-duty rollers

### Auxiliary Hydraulics

Hammer Circuit  
    For single function (1 way/2 pump) hydraulic tools  
Lines for booms and sticks  
Thumb Circuit  
    For double function (2 way/1 pump) hydraulic tools  
Tool Control System  
    Capability of adding medium pressure  
    For single or double function (1 or 2 way, 1 or 2 pump) hydraulic tools  
    Joysticks with additional switches  
    Medium pressure circuit (added to Tool Control only) for tools requiring medium pressure  
    Program up to 10 tools in memory

# 321D LCR Hydraulic Excavator

For more complete information on Cat products, dealer services, and industry solutions, visit us on the web at [www.cat.com](http://www.cat.com)

Materials and specifications are subject to change without notice. Featured machines in photos may include additional equipment. See your Caterpillar dealer for available options.

© 2007 Caterpillar -- All rights reserved

CAT, CATERPILLAR, their respective logos, "Caterpillar Yellow" and the POWER EDGE trade dress as well as corporate and product identity used herein, are trademarks of Caterpillar and may not be used without permission.

HEHH3331 (04/2007) hr

**CATERPILLAR**<sup>®</sup>

*Courtesy of Machine.Market*