

323F L

Hydraulic Excavator



Engine

Engine Model	Cat® C7.1 ACERT™	
Net Power – SAE J1349/ISO 9249	120 kW	161 hp

Drive

Maximum Travel Speed	5.5 km/h	3.4 mph
Maximum Drawbar Pull	205 kN	46,090 lbf

Weight

Operating Weight	23 100 kg	50,900 lb
------------------	-----------	-----------

Introduction

The new Cat 323FL is a purpose-built machine powered by a fuel-efficient U.S. EPA Tier 4 Final C7.1 ACERT engine. With plenty of counterweight, robust structures, a state-of-the-art hydraulic system, and Cat Grade Control Depth and Slope* you can move tons of material – literally – all day long with tremendous stability, speed, and precision.

When you add in a quiet operator environment that keeps you comfortable and productive, easy-to-reach service points that make your routine maintenance fast and simple, and multiple Cat work tools that help you take on a variety of tasks, you just won't find a better, more efficient 23-ton excavator – any place, anywhere.

Bottom line: If you are in the business of road construction, underground utilities, or commercial and residential site development, you need the versatile Cat 323FL in your fleet.

**Cat Grade Control Depth and Slope hardware is standard with R2.9 (9'6") sticks. See pages 4 and 5 for more details.*

Contents

Integrated Technologies	4
Engine	6
Hydraulics	8
Heavy Configuration	10
Operator Station	11
Front Linkage	12
Structures & Undercarriage	13
Attachments	14
Serviceability	16
Safety	17
Complete Customer Care	18
Sustainability	19
Specifications	20
Standard Equipment	34
Optional Equipment	35







Integrated Technologies

Monitor, manage, and enhance your job site operations

Cat CONNECT makes smart use of technology and services to improve your job site efficiency. Using the data from technology-equipped machines, you'll get more information and insight into your equipment and operations than ever before.

Cat Connect technologies offer improvements in these key areas:



EQUIPMENT
MANAGEMENT

Equipment Management – increase uptime and reduce operating costs.



PRODUCTIVITY

Productivity – monitor production and manage job site efficiency.



SAFETY

Safety – enhance job site awareness to keep your people and equipment safe.



LINK Technologies

LINK technologies like Product Link™ are deeply integrated into your machine and wirelessly communicate key information, including location, hours, fuel usage, idle time, and event codes.

Product Link/VisionLink®

Easy access to Product Link data via the online VisionLink user interface can help you see how your machine or fleet is performing. You can use this information to make timely, fact-based decisions that can boost job site efficiency and productivity and lower costs.

Cat GRADE with ASSIST

Cat GRADE with ASSIST delivers breakthrough gains in efficiency and productivity. With a touch of a button, the simple-to-use system automates grade work typically done by the operator with manual controls. In fact, operators at all experience levels can reach target grade up to 45% faster than with traditional grading techniques. It also has other built-in benefits such as grade protect, ceiling protect, and floor protect. Bottom line is you will get more speed and accuracy out of your machine with less manual input and fatigue.

Cat Grade Control Depth and Slope

The factory-integrated Cat Grade Control system, standard on the 323F with R2.9 (9'6") stick, delivers 2D bucket tip elevation guidance to the cab to help operators create precise planes and slopes with ease. Real-time bucket tip elevation guidance on the easy-to-read standard cab monitor indicates how much to cut or fill. Fast response sensors deliver immediate feedback. Integrated joystick buttons help operators make quick adjustments to maintain consistent, quality grades. Built-in alerts can be set to warn the operator if the linkage or bucket approaches a predefined elevation or depth like when working in areas with low ceilings or digging near water lines. Staking and checking is minimized, which reduces ground crews and enhances job site safety. The system works best in simple 2D applications such as digging basements or grading steep embankments. You can easily upgrade to AccuGrade™ when 3D control is required.

Cat AccuGrade

The dealer-installed AccuGrade system provides 3D guidance for making complex cuts and contours, eliminating the need for staking and checking. A dedicated monitor displays a digital design plan with 3D bucket tip positioning and elevation guidance, indicating precisely where to work and how much to cut or fill. The plug-and-play capability on the 323F L simplifies upgrading. Choose from satellite (GNSS) control for large projects with complex designs or total station (UTS) systems in areas with limited reception.



Engine

Powerful and fuel efficient to meet your expectations

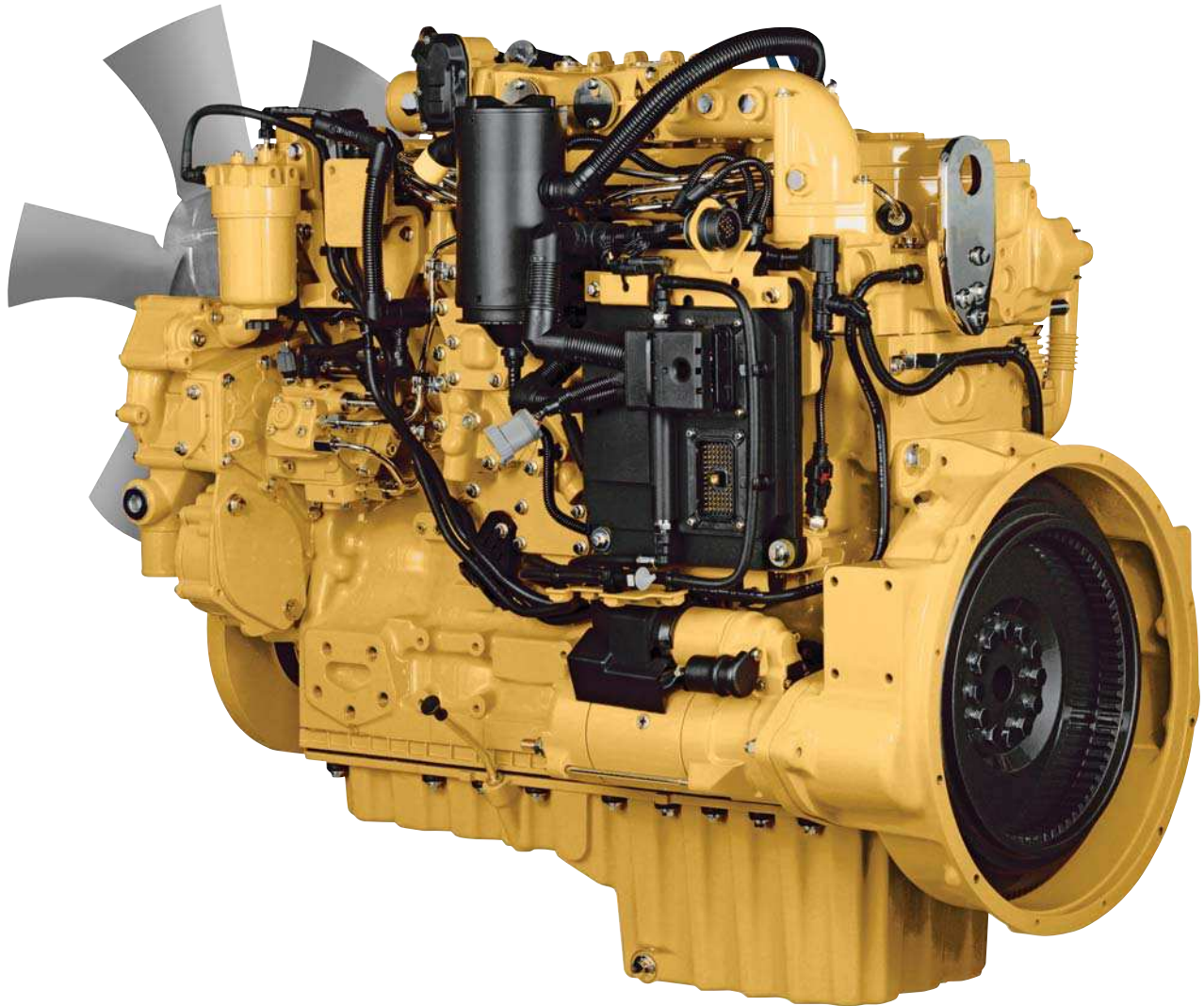

Proven Technology

Every Tier 4 Final ACERT engine is equipped with a combination of proven electronic, fuel, air, and aftertreatment components. Applying these time-tested technologies lets us meet your high expectations for productivity, fuel efficiency, reliability, and service life. Following are the results you can expect:

- **Improved fluid efficiency of up to 5%** over Tier 4 Interim products, including Diesel Exhaust Fluid (DEF) consumption.
- **High performance** across a variety of applications.
- **Enhanced reliability** through commonality and simplicity of design.
- **Maximized uptime and reduced cost** with world-class Cat dealer support.
- **Minimized impact** on emission systems – with no operator interaction required.
- **Durability** with long service life.
- **Better fuel economy** with minimized maintenance costs.
- **Same great power** and response.

More Powerful, Reliable Engine Electronics

Cat Tier 4 Final engine electronics are more powerful and robust than ever, enhancing your experience and increasing quality and reliability through the most demanding applications.

Next Generation Fuel Systems

Injection timing precisely controls the fuel injection process, which provides more control of combustion for the cleanest, most efficient fuel burn. To maximize your value, Caterpillar engineers specified fuel systems based on the power and performance demands for each engine. The high-pressure common rail fuel system with full electronic injection improves precision and control, reducing soot and boosting the engine's performance.

Innovative Air Management

Cat Tier 4 Final engines feature innovative air management systems that optimize airflow and enhance power, efficiency, and reliability. A range of simple, reliable turbocharging solutions based on engine size and application allows us to match turbo performance to rated output for high productivity, excellent fuel efficiency, long life, and low operating costs for you.

Cat NO_x Reduction System

The Cat NO_x Reduction System captures and cools a small quantity of exhaust gas and then routes it back into the combustion chamber to drive down temperatures and reduce NO_x emissions. The result of more than a decade of Caterpillar engineering research into this technology is the most reliable system of its type.

Aftertreatment Technologies

Caterpillar designed Tier 4 Interim products with Tier 4 Final standards in mind. By planning ahead, we minimized design changes to deliver the reliability and performance you demand. The aftertreatment solution utilized for Tier 4 Final products is the next evolutionary step for Cat engines with ACERT Technology. To meet the additional 80% reduction in NO_x emissions required by Tier 4 Final emission standards, Caterpillar engineers only needed to add one new system to the already proven aftertreatment solution in use, Selective Catalytic Reduction (SCR).

Diesel Exhaust Fluid (DEF)

Cat engines equipped with an SCR system inject DEF into the exhaust to reduce NO_x emissions. DEF is a precisely mixed solution of 32.5% high purity chemical grade urea and 67.5% de-ionized water. DEF used in Cat SCR systems must meet the requirements outlined in the International Organization for Standardization (ISO) standard 22241-1. ISO 22241-1 requirements are met by many brands of DEF, including those that carry the AdBlue or API certifications.

An Emissions Solution That Works

The Cat C7.1 ACERT engine meets Tier 4 Final emission standards, and it does so without interrupting your job process. In fact, the engine's diesel particulate filter is maintenance free. Simply turn the engine on and go to work.

Fuel Savers That Add Up

The 323F L consumes up to 10% less fuel than the previous series model, and lowering engine speed without impacting production is one of the key contributors. Automatic engine speed control also contributes by lowering rpm when the machine doesn't need it for work. Automatic engine idle shutdown turns the engine off when it's been idling for more than a specified amount of time that you can set through the monitor. Plus you have a choice of three power modes – high power, standard power, and eco mode. Simply change between modes through the console switch panel to meet the work needs in front of you. Collectively, all of these benefits add up to reduced fuel consumption, reduced exhaust and sound emissions, reduced repair and maintenance costs, and increased engine life for you.

A Cool Design For Any Temperature

A side-by-side cooling system allows you to put the machine to work in extremely hot and cold conditions. The system is completely separated from the engine compartment to reduce noise and heat. Plus it features easy-to-clean cores and a variable-speed fan that runs only when needed to ensure maximum efficiency.

Biodiesel Not A Problem

The C7.1 ACERT engine can run on B20 biodiesel that meets ASTM 6751 standards – all to give you more potential fuel-saving flexibility.

Hydraulics

Power to move your material with speed and precision



A Powerful, Efficient Design

When it comes to moving heavy material quickly and efficiently, you need hydraulic horsepower – the type of ground-breaking power the 323F L can deliver. Major hydraulic components like pumps and valves are located close together so shorter tubes and lines can be used. This design leads to less friction loss, reduced pressure drops, and more power to the ground for the work you need to get done.

Control Like No Other

Controllability is one of the main attributes of Cat excavators, and one of the key contributors to this is the main control valve. The valve opens slowly when your range of joystick lever movement is small and opens rapidly when movement is high. It puts flow where you need it when you need it, which leads to smoother operation, greater efficiency, and lower fuel consumption.

Auxiliary Hydraulics For Added Versatility

Auxiliary hydraulics give you greater tool versatility so you can take on more work with just one machine, and there are several options from which you can choose. A quick coupler circuit, for example, will allow you to switch from one tool to another in a matter of minutes – all from the comfort and convenience of the cab.

Boom & Stick Oil Re-Circulation For Added Efficiency

The 323F L regenerates the flow of oil from the head end of the boom and stick cylinders to the rod end of the boom and stick cylinders during the work cycle to save energy and improve fuel efficiency. It's optimized for any dial speed setting you select, which results in less pressure loss for higher controllability, more productivity, and lower operating costs for you.





Heavy Configuration

More brawn for your bigger jobs

More Lift

If your jobs require a lot of heavy lifting, look into the 323F L heavy counterweight configuration. This machine features nearly 5350 kg (11,800 lb) of weight out back – roughly 1250 kg (3,000 lb) more than our standard 323F L. It also has a reinforced frame to support the additional weight along with larger boom cylinders and heavy-duty undercarriage. The benefit to you is a well-designed, well-balanced machine that will lift up to 20 percent more weight out front and over the side than our standard model.

More Stability

With the heavy counterweight, you get a more stable platform for working with larger tools like a hydraulic thumb, multi-processor, and high-capacity buckets. It also helps keep the machine flat on its tracks when you are picking and placing large pipe and trench boxes, concrete construction barriers, and other heavy materials.

More Reach

If reach is what you need, you can stretch your working envelope with an optional R3.9 (12'10") stick. Built specifically for the heavy counterweight configuration, this stick combined with a heavy-duty boom will give you over 7580 mm (24'10") of dig depth and 10 680 mm (35'0") of reach, making it ideal for deep sewer applications.



Operator Station

Comfort and convenience to keep you productive

A Safe, Quiet Cab

The ROPS cab provides you with a safe working environment. It also contributes to your comfort because it's attached to a reinforced frame with special viscous mounts that limit vibration and unnecessary sound. Add in special roof lining and sealing and you have a cab that's as quiet inside as today's top pickup trucks.

Comfortable Seat Options

The seat range includes air suspension, heated, and air cooled options. All seats include a reclining back, upper and lower slide adjustments, and height and tilt angle adjustments to meet your needs for maximum comfort.

A Cool & Warm Environment

The automatic climate control system features multiple air outlets with filtered ventilation. Air flows on the floor, behind the seat, and in front of you to make your work in either hot or cold weather much more pleasant and productive.

Controls Just For You

The right and left joystick consoles can be adjusted to improve your comfort and productivity during the course of a day. Also, the right joystick features a button that will reduce engine speed when you are not working to help save fuel. Touch it once and speed reduces; touch it again and speed increases for normal operation.

A Helpful Monitor

The LCD monitor is easy to see and navigate. Programmable in up to 42 languages to meet today's diverse workforce, the monitor clearly displays critical information you need to operate efficiently and effectively. Plus it projects the image from the standard rearview camera to help you see what's going on around you so you can stay safely focused on the job at hand.

Ample Storage & Auxiliary Power

Storage spaces are located in the front, rear, and side consoles of the cab. A drink holder accommodates a large mug, and a shelf behind the seat stores large lunch or toolboxes. Two 12-volt power supply sockets are conveniently located near the key storage areas for charging your electronic devices like an MP3 player, a cell phone, or a tablet.





Front Linkage

Options to take on your far-reaching and up-close tasks

Booms & Sticks

The 323F is offered with a range of booms and sticks. Each is built with internal baffle plates for added durability, and each undergoes ultrasound inspection to ensure weld quality and reliability. Large box-section structures with thick, multi-plate fabrications, castings, and forgings are used in high-stress areas such as the boom nose, boom foot, boom cylinder, and stick foot to improve durability. The boom nose pin is a captured flag design for enhanced durability.

Two Types Available

There are two basic boom types available to meet your work needs: HD and SLR.

HD = Heavy Duty

This type of boom is best for the majority of your applications like up-close excavating, heavy-duty lifting, and breaking and demolishing a variety of material.

SLR = Super Long Reach

With reaches up to 15 720 mm (51'7"), this configuration is ideal for forming slopes and cleaning settlement tanks and ponds.

Sticks are matched to the boom you choose. Longer sticks are better when you need to dig deep or load trucks. Shorter sticks provide greater breakout force and increase your productivity when using hydromechanical work tools.

Talk to your Cat dealer to pick the best front linkage for your specific line of work.

Structures & Undercarriage

Built to work in your rugged applications



Robust Frame

The 323F L is a well-built machine designed to give you a very long service life. The upper frame has mountings made specifically to support the heavy-duty cab; it is also reinforced around key areas that take on stress like the boom foot and skirt. Massive bolts are used to attach the track frames to the body, and additional bolts are used to increase the machine's digging force, which leads to more productivity for you.

Durable Undercarriage

The 323F L undercarriage contributes significantly to its outstanding stability and durability. Track shoes, links, rollers, idlers, and final drives are all built with long-lasting, high-tensile-strength steel. Cat Grease Lubricated Track 2 (GLT2) track link protects moving parts by keeping water, debris, and dust out and grease sealed in, which delivers longer wear life and reduced noise when traveling on either a flat, heavy bed of rock or a steep, wet field of mud.

Counterweight Options

Depending on the configuration you choose, three counterweight options – 4.1 mt (9,040 lb), 4.7 mt (10,360 lb), and 5.35 mt (11,790 lb) – are available. All are built with thick steel plates and reinforced fabrications to make them less susceptible to damage, and all have curved surfaces that match the machine's sleek, smooth appearance along with integrated housings to help protect the standard rearview camera.



Attachments

Tools to make you productive and profitable



Get The Most Out Of One Machine

You can easily expand the performance of your machine by utilizing any of the variety of attachments offered by Cat Work Tools.

Change Jobs Quickly & Accurately

Quick couplers like the Cat Pin Grabber allow you to switch tools for the job at hand with incredible ease and speed, helping to maximize your uptime. Caterpillar's optional tool control system takes it a step further by adding best-in-class accuracy because it can store the flows and pressures of up to 10 different work tools. Simply select the tool you need through the monitor and go to work – quickly and efficiently.

Dig, Finish, Load & Compact

A wide range of buckets dig everything from top soil to harsh, abrasive material. For finishing and grading work, compact and shallow ditch cleaning buckets fit the need. A Cat compactor prepares the area for the next phase of construction.

Break, Demolish & Scrap

A hydraulic hammer equips your machine for breaking rock in quarries and preparing trenches on construction sites. Taking down bridge pillars and heavily reinforced concrete is no problem. Multi-processor, pulverizer, and shear attachments take your machine into structure demolition jobs and process the debris for reuse and recycle.

Move & Handle

Add a thumb and you have the ability to move and handle brush, rocks, and debris. For constant material handling, a grapple is your solution. Choose from three different styles for picking, sorting, and loading trash, demolition debris, or recyclables.

Set Up Your Machine For Profitability

Your Cat dealer can install hydraulic kits to properly operate all Cat Work Tool attachments – maximizing the machine's uptime and your profits. All Cat Work Tool attachments are supported by the same Cat dealer network as your Cat machine.

GRAB, SORT, LOAD



Pro Series Hydraulic Thumbs



Stiff Link Thumbs



Contractors' Grapples



Trash Grapples

SWAP TOOLS



Pin Grabber Coupler

DIG & PACK



Ditch Cleaning and Tilt Buckets



General Duty Buckets



Heavy Duty Buckets



Severe Duty Buckets



Vibratory Plate Compactors

CUT, CRUSH, BREAK & RIP



Multi-Processors



Scrap & Demolition Shears



Secondary Pulverizers



Hydraulic Hammers



Rippers

Serviceability

Designed to make your maintenance quick and easy

Safe, Convenient Access

You can reach most routine maintenance items like fluid taps and grease points from the safety and convenience of ground level. You will also find filters banked together for higher service efficiency. Compartments feature wide service doors designed to help prevent debris entry, and they also securely latch in place to help make your service work simpler.



A Cool Design

The high-ambient cooling system features a fuel-saving variable-speed fan and a side-by-side-mounted radiator and oil and air coolers for easy cleaning. Wider clearance between the two makes blowing off debris easy for you, which can help improve your machine's reliability and performance.

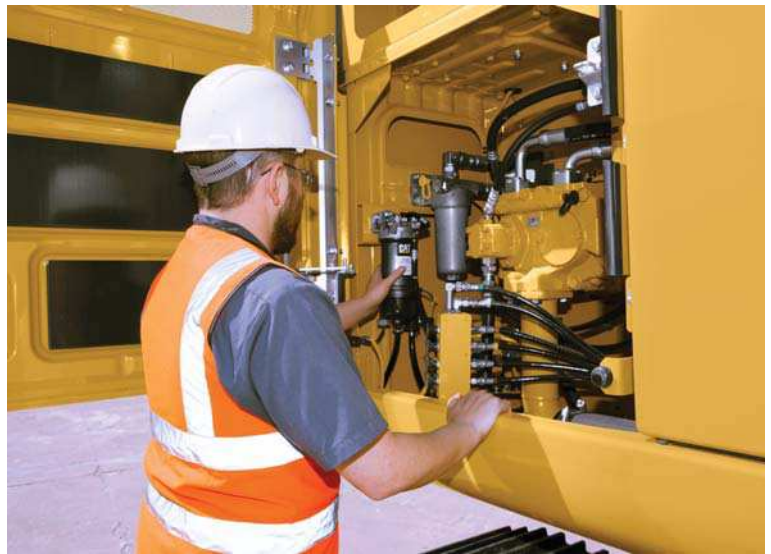

A Fresh Idea

When you select ventilation inside the cab, outside air enters through the fresh air filter. The filter is conveniently located on the side of the cab to make it easy to reach and replace, and it is protected by a lockable door that can be opened with the engine key.

More Service Benefits

Filters are banked together to enhance service efficiency. The fuel tank's drain cock makes it easy and simple for you to remove water and sediment during routine maintenance. Plus an integrated fuel level indicator pops up to help you reduce the possibility of fuel tank overfilling.

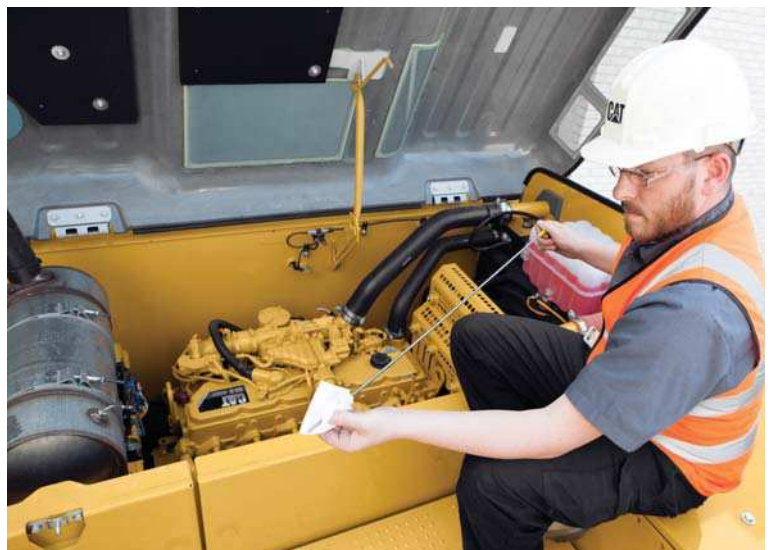

Safety

Features to help protect you day in and day out



A Safe, Quiet Cab

The ROPS cab provides you with a safe working environment when properly seated and belted. It also contributes to your comfort because it's attached to a reinforced frame with special viscous mounts that limit vibration and unnecessary sound. Add in special roof lining and sealing and you have a cab that's as quiet inside as any of today's top pickup trucks.

Secure Contact Points

Multiple large steps get you into the cab as well as a leg up to the compartments. Extended hand and guard rails allow you to safely climb to the upper deck. Anti-skid plates reduce your slipping hazards in all types of weather conditions, and they can be removed for cleaning.

Great Views

Ample glass gives you excellent visibility out front and to the side, and the standard rearview camera gives you a clear field of view behind the machine through the cab monitor. The available split-configuration windshield features an upper window with handles that make it easy to slide and store above you and a lower window that can be removed and stored on the inside wall of the cab. The large skylight also serves as an emergency exit and provides you with enhanced overhead visibility.

Smart Lighting

Halogen lights provide plenty of illumination, and the cab and boom lights can be programmed to stay on for up to 90 seconds after the engine has been turned off to help you safely exit the machine.

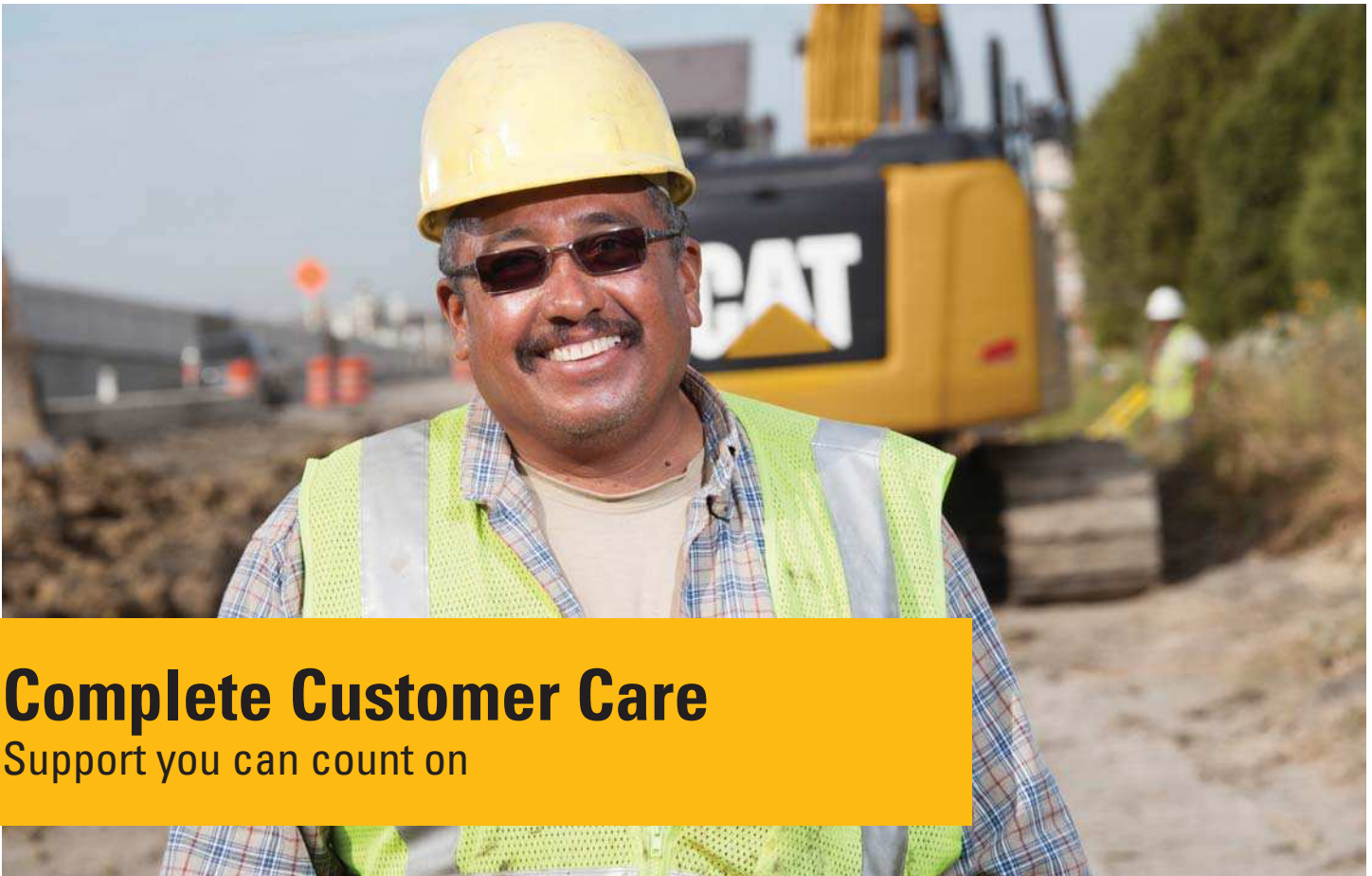

Complete Customer Care

Support you can count on

Worldwide Parts Availability

Cat dealers utilize a worldwide parts network to maximize your machines' uptime. Plus they can help you save money with Cat remanufactured components.

Advice You Can Trust

What are the job requirements and machine attachments? What production is needed? Your Cat dealer can provide recommendations to help you make the right machine choices.

Financial Options Just For You

Consider financing options and day-to-day operating costs. Look at dealer services that can be included in the machine's cost to yield lower owning and operating costs over time.

Support Agreements To Fit Your Needs

Cat dealers offer a variety of customer support agreements and work with you to develop a plan to meet your specific needs. These plans can cover the entire machine, including attachments, to help protect your investment.

Operating Techniques To Boost Your Profits

Improving operating techniques can boost your profits. Your Cat dealer has videos, literature, and other ideas to help you increase productivity. Caterpillar also offers simulators and certified operator training to help maximize the return on your investment.

What's Best For You Today... And Tomorrow

Repair, rebuild, or replace? Your Cat dealer can help you evaluate the cost involved so you can make the best choice for your business.

Sustainability

Generations ahead in every way



- The C7.1 ACERT engine meets Tier 4 Final emission standards.
- The 323F L burns less fuel than the 320E model it replaces, which means less emissions.
- Cat Grade Control Depth and Slope is standard with the R2.9 (9'6") stick, improving job site efficiency.
- The machine has the flexibility of running on either ultra-low-sulfur diesel (ULSD) fuel with 15 ppm of sulfur or less or biodiesel (B20) fuel blended with ULSD.
- A ground-level overfill indicator rises when the tank is full to help the operator avoid spilling.
- The QuickEvac™ option ensures fast, easy, and secure changing of engine and hydraulic oil.
- The machine is built to be rebuilt with major structures and components capable of being remanufactured to reduce waste and replacement costs.
- Overall, the 323F L is an efficient, productive machine that's designed to conserve our natural resources for generations ahead.

323F L Hydraulic Excavator Specifications

Engine

Engine Model	Cat C7.1 ACERT	
Net Power – SAE J1349/ISO 9249	120 kW	161 hp
Net Power – ISO 14396	121 kW	162 hp
Engine rpm		
Operation	1,500 rpm	
Travel	1,800 rpm	
Bore	105 mm	4.1 in
Stroke	135 mm	5.3 in
Displacement	7.1 L	433 in ³

- The 323F L meets worldwide Tier 4 Final emission standards.
- No engine power derating required below 3000 m (9,840 ft) altitude.
- Net power advertised is the power available at the flywheel when the engine is equipped with fan, air cleaner, muffler and alternator.
- Rating at 1,800 rpm (Implement).

Weights

Operating Weight	23 100 kg	50,900 lb
------------------	-----------	-----------

• Long Undercarriage, Reach Boom R2.9 (9'6"), 1.19 m³ (1.56 yd³) bucket and 790 mm (31 in) shoes.

Track

Standard with Long Undercarriage	790 mm	31 in
Optional for Long Undercarriage	600 mm	24 in
Number of Shoes Each Side – Long Undercarriage	49	
Number of Track Rollers Each Side – Long Undercarriage	8	
Number of Carrier Rollers Each Side	2	

Swing Mechanism

Swing Speed	11.0 rpm	
Swing Torque	61.8 kN·m	45,580 lbf·ft

Drive

Maximum Travel Speed	5.5 km/h	3.4 mph
Maximum Drawbar Pull	205 kN	46,090 lbf

Hydraulic System

Main System		
Maximum Flow (2 pumps)	423 L/min	112 gal/min
Maximum Flow (per pump)	212 L/min	56 gal/min
Maximum Pressure – Equipment – Heavy Lift Mode	38 000 kPa	5,511 psi
Maximum Pressure – Equipment/Travel	35 000 kPa	5,076 psi
Maximum Pressure – Swing	25 500 kPa	3,698 psi
Pilot System Maximum Flow for Implement	20 L/min	5.3 gal/min
Pilot System Maximum Pressure	3920 kPa	569 psi
Boom Cylinder – Bore	120 mm	4.7 in
Boom Cylinder – Stroke	1260 mm	49.6 in
Stick Cylinder – Bore	140 mm	5.5 in
Stick Cylinder – Stroke	1504 mm	59.2 in
Bucket Cylinder – Bore	120 mm	4.7 in
Bucket Cylinder – Stroke	1104 mm	43.5 in

Service Refill Capacities

Fuel Tank Capacity	410 L	108.3 gal
Cooling System	30 L	7.9 gal
Engine Oil	25 L	6.6 gal
Swing Drive (each)	8 L	2.1 gal
Final Drive (each)	8 L	2.1 gal
Hydraulic System (including tank)	159 L	42.0 gal
Hydraulic Tank	143 L	37.8 gal
DEF Tank	20 L	5.3 gal

Sound Performance

ISO 6395 (External)	102 dB(A)
ISO 6396 (Inside Cab)	68 dB(A)

- When properly installed and maintained, the cab offered by Caterpillar, when tested with doors and windows closed according to ANSI/SAE J1166 OCT98, meets OSHA and MSHA requirements for operator sound exposure limits in effect at time of manufacture.
- Hearing protection may be needed when operating with an open operator station and cab (when not properly maintained or doors/windows open) for extended periods or in a noisy environment.

Standards

Brakes	ISO 10265 2008
Cab/FOGS	ISO 10262 1998
Cab/ROPS	ISO 12117-2 2008

323F L Hydraulic Excavator Specifications

Dimensions

All dimensions are approximate.

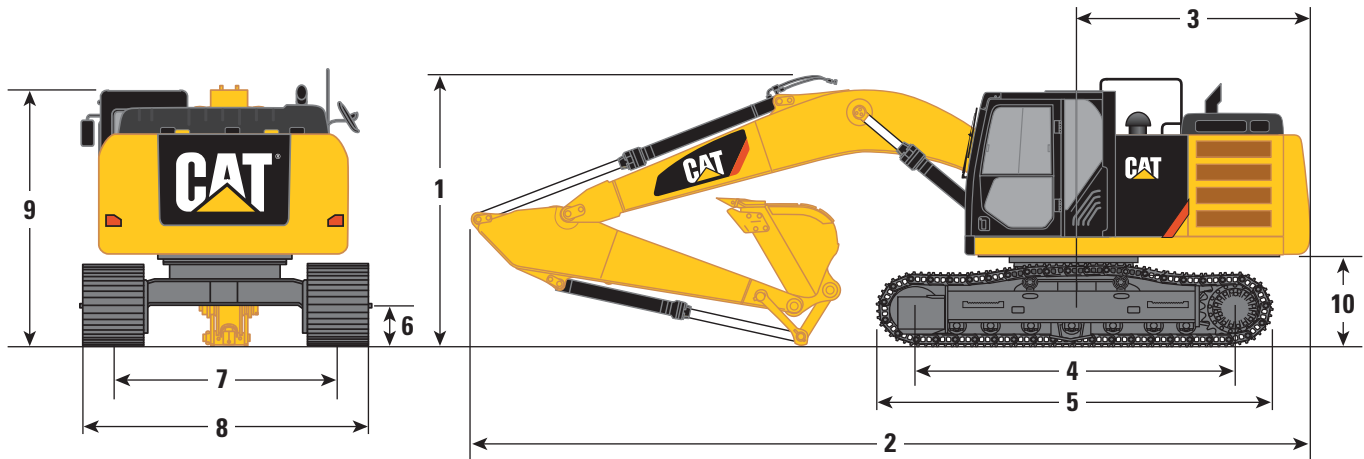

Boom Options	HD Reach Boom 5.7 m (18'8")		Super Long Reach 8.85 m (29'0")			
	R2.9 (9'6")**	R3.9 (12'10")*	SLR 6.28 m (20'7")***			
Stick Options						
1 Shipping Height	3130 mm	10'3"	3450 mm	11'4"	3210 mm	10'6"
2 Shipping Length	9540 mm	31'4"	9340 mm	30'8"	12 750 mm	41'10"
3 Tail Swing Radius	2830 mm	9'3"	2830 mm	9'3"	2830 mm	9'3"
4 Length to Center of Rollers – Long Undercarriage	3650 mm	12'0"	3650 mm	12'0"	3650 mm	12'0"
5 Track Length – Long Undercarriage	4460 mm	14'8"	4460 mm	14'8"	4460 mm	14'8"
6 Ground Clearance	450 mm	1'6"	450 mm	1'6"	450 mm	1'6"
7 Track Gauge – Long Undercarriage (shipping)	2380 mm	7'10"	2380 mm	7'10"	2380 mm	7'10"
8 Transport Width – Long Undercarriage						
600 mm (24 in) Shoes	2980 mm	9'9"	2980 mm	9'9"	2980 mm	9'9"
790 mm (31 in) Shoes	3170 mm	10'5"	3170 mm	10'5"	3170 mm	10'5"
9 Handrail Height	3010 mm	9'11"	3010 mm	9'11"	3010 mm	9'11"
10 Counterweight Clearance	1020 mm	3'4"	1020 mm	3'4"	1020 mm	3'4"

*With GD 0.81 m³ (1.06 yd³) bucket and 790 mm (31 in) shoes.

**With HD 1.19 m³ (1.56 yd³) bucket and 790 mm (31 in) shoes.

***With GP 0.57 m³ (0.75 yd³) bucket and 790 mm (31 in) shoes.

323F L Hydraulic Excavator Specifications

Working Ranges

All dimensions are approximate.

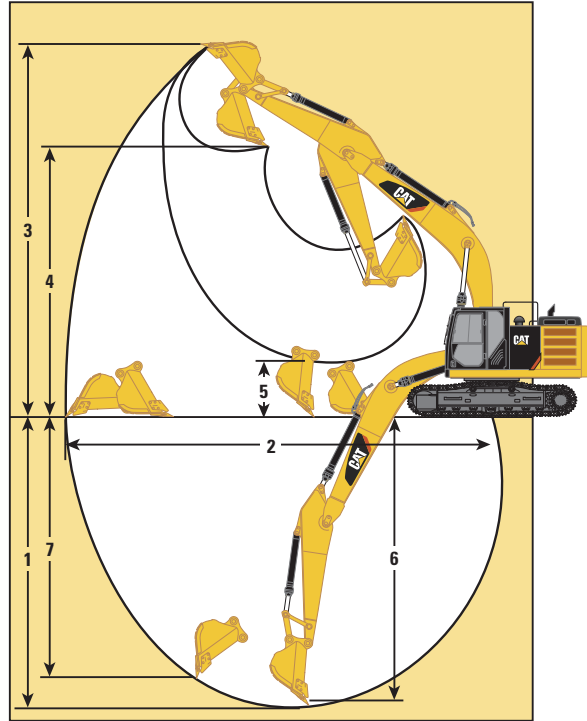

Boom Options

HD Reach Boom
5.7 m (18'8")

Stick Options

R2.9 (9'6")

R3.9 (12'10")

Bucket Type and Capacity

HD 1.19 m³ (1.56 yd³)

GD 0.81 m³ (1.06 yd³)

	R2.9 (9'6")		R3.9 (12'10")	
	HD 1.19 m ³ (1.56 yd ³)		GD 0.81 m ³ (1.06 yd ³)	
1 Maximum Digging Depth	6720 mm	22'1"	7580 mm	24'10"
2 Maximum Reach at Ground Line	9860 mm	32'4"	10 680 mm	35'0"
3 Maximum Cutting Height	9370 mm	30'9"	9890 mm	32'5"
4 Maximum Loading Height	6490 mm	21'4"	7030 mm	23'1"
5 Minimum Loading Height	2170 mm	7'1"	1310 mm	4'4"
6 Maximum Depth Cut for 2440 mm (8'0") Level Bottom	6550 mm	21'6"	7440 mm	24'5"
7 Maximum Vertical Wall Digging Depth	5060 mm	16'7"	6910 mm	22'8"
Tip Bucket Digging Force (SAE)	134 kN	30,100 lbf	132 kN	29,630 lbf
Cutting Edge Bucket Digging Force (ISO)	150 kN	33,810 lbf	148 kN	33,250 lbf
Tip Stick Digging Force (SAE)	103 kN	23,220 lbf	88 kN	19,870 lbf
Cutting Edge Stick Digging Force (ISO)	106 kN	23,920 lbf	91 kN	20,370 lbf

323F L Hydraulic Excavator Specifications

Working Ranges

All dimensions are approximate.

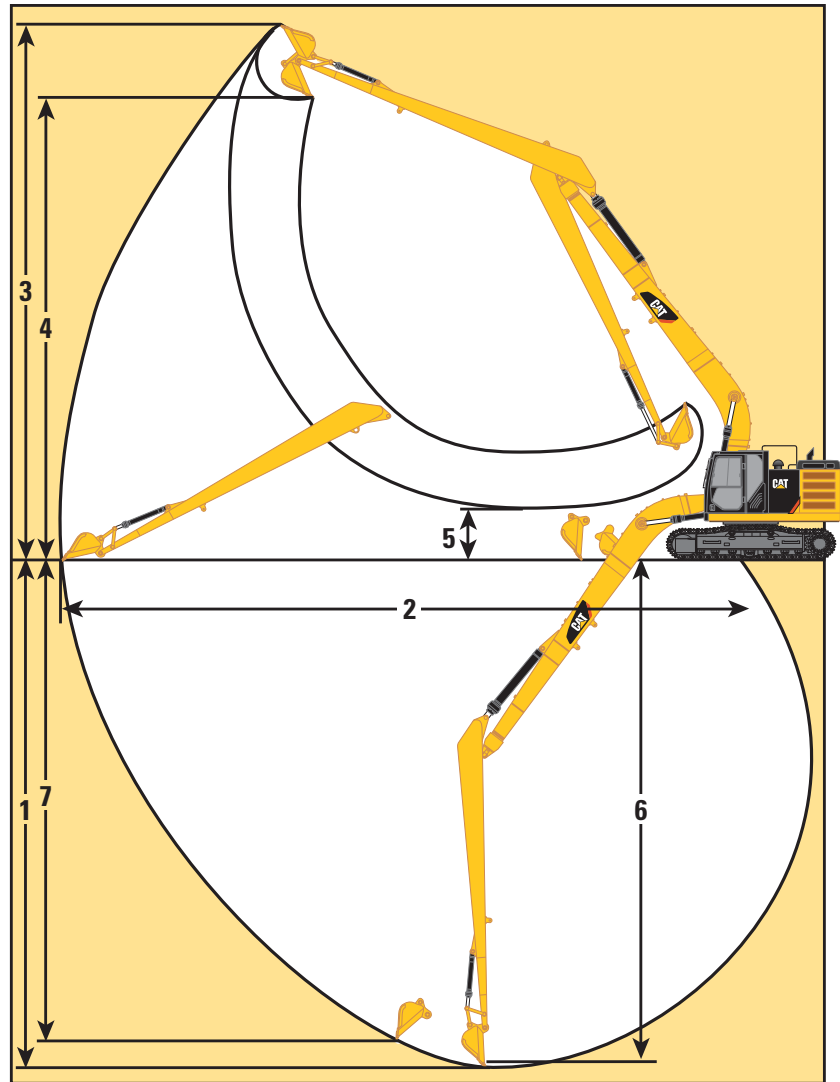

Boom Option

Super Long Reach Boom
8.85 m (29'0")

Stick Option

SLR
6.28 m (20'7")

Bucket Type and Capacity

General Purpose 0.57 m³ (0.75 yd³)

1 Maximum Digging Depth	11 690 mm	38'4"
2 Maximum Reach at Ground Level	15 720 mm	51'7"
3 Maximum Cutting Height	13 590 mm	44'7"
4 Maximum Loading Height	11 290 mm	37'0"
5 Minimum Loading Height	2090 mm	6'10"
6 Maximum Depth Cut for 2440 mm (8'0") Level Bottom	11 280 mm	37'0"
7 Maximum Vertical Wall Digging Depth	10 670 mm	35'0"
Tip Bucket Digging Force (SAE)	54 kN	12,190 lbf
Cutting Edge Bucket Digging Force (ISO)	61 kN	13,690 lbf
Tip Stick Digging Force (SAE)	48 kN	10,810 lbf
Cutting Edge Stick Digging Force (ISO)	49 kN	10,950 lbf

323F L Hydraulic Excavator Specifications

Operating Weights and Ground Pressures

	790 mm (31 in) Shoes (Triple Grouser)			
	Weight		Ground Pressure	
Standard Configuration – 4.1 mt (9,040 lb) Counterweight HD Reach Boom – 5.7 m (18'8")				
R2.9 (9'6") Stick, GD 1.3 m ³ (1.70 yd ³) Bucket	23 000 kg	50,700 lb	36.3 kPa	5.27 psi
Heavy Counterweight Configuration – 5.35 mt (11,700 lb) Counterweight HD Reach Boom – 5.7 m (18'8")				
R2.9 (9'6") Stick, HD 1.19 m ³ (1.56 yd ³) Bucket	25 100 kg	55,300 lb	39.7 kPa	5.75 psi
R2.9 (9'6") Thumb Stick, HD 1.19 m ³ (1.56 yd ³) Bucket	25 400 kg	56,000 lb	40.1 kPa	5.82 psi
R3.9 (12'10") Stick, GD 0.81 m ³ (1.06 yd ³) Bucket	25 000 kg	55,100 lb	39.5 kPa	5.73 psi
Super Long Reach Configuration – 4.7 mt (10,360 lb) Counterweight Super Long Reach Boom – 8.85 m (29'0")				
SLR 6.28 m (20'7") Stick, Ditch Cleaning 0.57 m ³ (0.75 yd ³) Bucket	24 100 kg	53,100 lb	38.1 kPa	5.52 psi
	600 mm (24 in) Shoes (Single Grouser)			
	Weight		Ground Pressure	
Standard Configuration – 4.1 mt (9,040 lb) Counterweight HD Reach Boom – 5.7 m (18'8")				
R2.9 (9'6") Stick, GD 1.3 m ³ (1.70 yd ³) Bucket	22 700 kg	50,000 lb	47.2 kPa	6.85 psi
R2.9 (9'6") Stick, HD 1.19 m ³ (1.56 yd ³) Bucket	22 800 kg	50,300 lb	47.4 kPa	6.88 psi
Super Long Reach Configuration – 4.7 mt (10,360 lb) Counterweight Super Long Reach Boom – 8.85 m (29'0")				
SLR 6.28 m (20'7") Stick, Ditch Cleaning 0.57 m ³ (0.75 yd ³) Bucket	23 800 kg	52,500 lb	49.5 kPa	7.18 psi









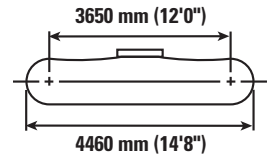
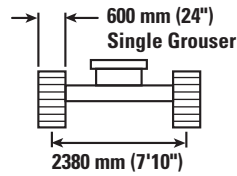
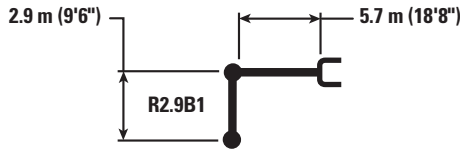



Major Component Weights

	kg	lb
Upper Structure with 4.1 mt (9,040 lb) Counterweight	11 190	24,670
Upper Structure with 4.7 mt (10,360 lb) Counterweight for Super Long Reach	11 790	25,990
Upper Structure with 5.35 mt (11,700 lb) Counterweight	12 650	27,890
Lower Structure with 790 mm (31 in) Triple Grouser HD Shoes	8320	18,340
Lower Structure with 790 mm (31 in) Triple Grouser Shoes	7880	17,370
Lower Structure with 600 mm (24 in) Single Grouser Shoes	7620	16,800
HD Reach Boom (includes lines, pins, two boom cylinders, stick cylinder)	2010	4,430
HD Reach Boom, Heavy Counterweight Configuration (includes lines, pins, two boom cylinders, stick cylinder)	2100	4,630
Super Long Reach Boom (includes lines, pins, two boom cylinders, stick cylinder)	2740	6,040
R3.9 (12'10") Stick (includes lines, pins, bucket cylinder and linkage)	1230	2,710
R2.9 (9'6") Stick (includes lines, pins, bucket cylinder and linkage)	980	2,160
R2.9 (9'6") Thumb Stick (includes lines, pins, bucket cylinder and linkage)	1250	2,760
Super Long Reach Stick (includes lines, pins, bucket cylinder and linkage)	1330	2,930
GD 0.81 m ³ (1.06 yd ³) Bucket	700	1,540
HD 1.19 m ³ (1.56 yd ³) Bucket	1020	2,250
GD 1.3 m ³ (1.70 yd ³) Bucket	880	1,940
Ditch Cleaning 0.57 m ³ (0.75 yd ³) Bucket	330	730

323F L Hydraulic Excavator Specifications

HD Reach Boom Lift Capacities – Counterweight: 4.1 mt (9,040 lb) – without Bucket



		1.5 m/5.0 ft		3.0 m/10.0 ft		4.5 m/15.0 ft		6.0 m/20.0 ft		7.5 m/25.0 ft				m ft-in
														
7.5 m 25.0 ft	kg lb							*4950	*4950			*4300	*4300	6.15 20.00
6.0 m 20.0 ft	kg lb							*5400 *11,850	*5400 *11,850			*3950 *8,750	*3950 *8,750	7.29 24.17
4.5 m 15.0 ft	kg lb							*5950 *12,900	5550 11,900	*5600 *12,250	3950 8,400	*3900 *8,550	3550 7,850	7.99 26.67
3.0 m 10.0 ft	kg lb					*8650 *18,650	8050 17,350	*6800 *14,800	5300 11,400	5900 12,650	3850 8,200	*4000 *8,750	3250 7,150	8.36 27.50
1.5 m 5.0 ft	kg lb					*10 500 *22,650	7550 16,250	*7750 *16,750	5050 10,900	5750 12,350	3700 8,000	*4200 *9,250	3150 6,900	8.45 28.33
0 m 0 ft	kg lb			*6600 *15,150	*6600 *15,150	*11 500 *24,900	7250 15,650	7800 16,800	4900 10,550	5650 12,150	3600 7,800	*4650 *10,250	3200 7,000	8.26 27.50
-1.5 m -5.0 ft	kg lb	*7050 *15,750	*7050 *15,750	*11 400 *25,850	*11 400 *25,850	*11 650 *25,200	7200 15,450	7750 16,650	4800 10,350	5650 12,100	3600 7,750	5350 11,800	3450 7,550	7.78 25.83
-3.0 m -10.0 ft	kg lb	*12 100 *27,100	*12 100 *27,100	*15 450 *33,450	14 000 29,950	*10 900 *23,550	7250 15,600	7800 16,750	4850 10,450			6350 14,050	4050 8,950	6.95 23.33
-4.5 m -15.0 ft	kg lb			*12 350 *26,400	*12 350 *26,400	*8850 *18,900	7450 16,100					*6700 *14,750	5550 12,500	5.60 18.33



ISO 10567



*Indicates that the load is limited by hydraulic lifting capacity rather than tipping load. The above loads are in compliance with hydraulic excavator lift capacity standard ISO 10567:2007. They do not exceed 87% of hydraulic lifting capacity or 75% of tipping load. Weight of all lifting accessories must be deducted from the above lifting capacities. Lifting capacities are based on the machine standing on a firm, uniform supporting surface. The use of a work tool attachment point to handle/lift objects, could affect the machine lift performance.









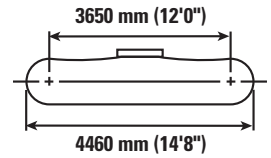
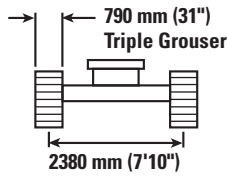
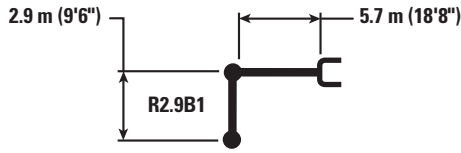



Lift capacity stays with ±5% for all available track shoes.

Always refer to the appropriate Operation and Maintenance Manual for specific product information.

323F L Hydraulic Excavator Specifications

HD Reach Boom Lift Capacities – Counterweight: 4.1 mt (9,040 lb) – without Bucket



		1.5 m/5.0 ft		3.0 m/10.0 ft		4.5 m/15.0 ft		6.0 m/20.0 ft		7.5 m/25.0 ft				m ft-in
														
7.5 m 25.0 ft	kg lb							*4950	*4950			*4300	*4300	6.15 20.00
6.0 m 20.0 ft	kg lb							*5450	*5450			*3950	*3950	7.29 24.17
4.5 m 15.0 ft	kg lb							*6000	5700	*5650	4050	*3900	3650	7.99 26.67
3.0 m 10.0 ft	kg lb					*8800	8250	*6900	5450	*6050	3950	*4000	3350	8.36 27.50
1.5 m 5.0 ft	kg lb					*10 650	7800	*7850	5250	5950	3850	*4200	3250	8.45 28.33
0 m 0 ft	kg lb			*6600	*6600	*11 650	7500	8050	5050	5850	3750	*4650	3300	8.26 27.50
-1.5 m -5.0 ft	kg lb	*7050	*7050	*11 400	*11 400	*11 800	7450	8000	5000	5800	3750	*5500	3550	7.78 25.83
-3.0 m -10.0 ft	kg lb	*12 100	*12 100	*15 600	14 400	*11 050	7500	8000	5000			6500	4150	6.95 23.33
-4.5 m -15.0 ft	kg lb			*12 500	*12 500	*9000	7700					*6800	5700	5.60 18.33
				*26,750	*26,750	*19,100	16,550					*14,950	12,800	



ISO 10567



*Indicates that the load is limited by hydraulic lifting capacity rather than tipping load. The above loads are in compliance with hydraulic excavator lift capacity standard ISO 10567:2007. They do not exceed 87% of hydraulic lifting capacity or 75% of tipping load. Weight of all lifting accessories must be deducted from the above lifting capacities. Lifting capacities are based on the machine standing on a firm, uniform supporting surface. The use of a work tool attachment point to handle/lift objects, could affect the machine lift performance.









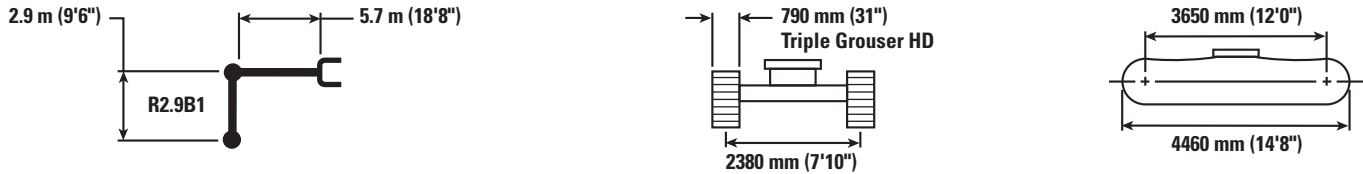



Lift capacity stays with ±5% for all available track shoes.

Always refer to the appropriate Operation and Maintenance Manual for specific product information.

323F L Hydraulic Excavator Specifications

HD Reach Boom Lift Capacities – Heavy Counterweight: 5.35 mt (11,700 lb) – without Bucket



		1.5 m/5.0 ft		3.0 m/10.0 ft		4.5 m/15.0 ft		6.0 m/20.0 ft		7.5 m/25.0 ft				m ft-in
														
7.5 m 25.0 ft	kg lb							*4950 *13,150	*4950 *13,150			*4300 *9,500	*4300 *9,500	6.15 20.00
6.0 m 20.0 ft	kg lb							*6000 *13,150	*6000 *13,150			*3950 *8,750	*3950 *8,750	7.29 24.17
4.5 m 15.0 ft	kg lb							*6600 *14,350	6550 14,150	*6200 *12,450	4700 10,150	*3900 *8,550	*3900 *8,550	7.99 26.67
3.0 m 10.0 ft	kg lb					*9650 *20,750	9550 20,600	*7600 *16,450	6350 13,650	*6650 *14,450	4600 9,950	*4000 *8,750	3950 8,700	8.36 27.50
1.5 m 5.0 ft	kg lb					*11 700 *25,200	9100 19,550	*8600 *18,650	6100 13,150	6800 14,650	4500 9,700	*4200 *9,250	3850 8,400	8.45 28.33
0 m 0 ft	kg lb			*6600 *15,150	*6600 *15,150	*12 800 *27,700	8800 18,950	9250 19,900	5950 12,800	6700 14,450	4400 9,500	*4650 *10,250	3900 8,550	8.26 27.50
-1.5 m -5.0 ft	kg lb	*7050 *15,750	*7050 *15,750	*11 400 *25,850	*11 400 *25,850	*12 950 *28,000	8700 18,750	9150 19,700	5850 12,650	6700 14,400	4400 9,450	*5500 *12,100	4200 9,250	7.78 25.83
-3.0 m -10.0 ft	kg lb	*12 100 *27,100	*12 100 *27,100	*17 150 *37,150	16 800 36,000	*12 100 *26,200	8750 18,850	*9000 *19,400	5900 12,700			*7100 *15,800	4900 10,850	6.95 23.33
-4.5 m -15.0 ft	kg lb			*13 700 *29,400	*13 700 *29,400	*9900 *21,050	8950 19,300					*7500 *16,450	6650 14,950	5.60 18.33



ISO 10567



*Indicates that the load is limited by hydraulic lifting capacity rather than tipping load. The above loads are in compliance with hydraulic excavator lift capacity standard ISO 10567:2007. They do not exceed 87% of hydraulic lifting capacity or 75% of tipping load. Weight of all lifting accessories must be deducted from the above lifting capacities. Lifting capacities are based on the machine standing on a firm, uniform supporting surface. The use of a work tool attachment point to handle/lift objects, could affect the machine lift performance.

Lift capacity stays with ±5% for all available track shoes.

Always refer to the appropriate Operation and Maintenance Manual for specific product information.

323F L Hydraulic Excavator Specifications

HD Reach Boom Lift Capacities – Heavy Counterweight: 5.35 mt (11,700 lb) – without Bucket

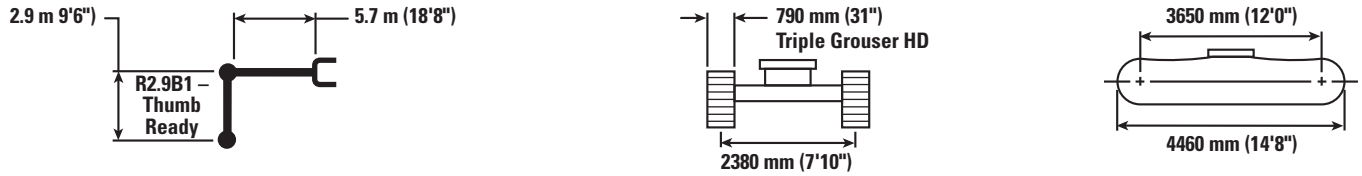

		1.5 m/5.0 ft		3.0 m/10.0 ft		4.5 m/15.0 ft		6.0 m/20.0 ft		7.5 m/25.0 ft		m ft-in		
7.5 m 25.0 ft	kg lb							*4900	*4900			*4200 *9,350	*4200 *9,350	6.15 20.00
6.0 m 20.0 ft	kg lb							*5850 *12,800	*5850 *12,800			*3900 *8,600	*3900 *8,600	7.29 24.17
4.5 m 15.0 ft	kg lb							*6400 *13,950	*6400 13,850	*6050 *12,300	4550 9,800	*3850 *8,400	*3850 *8,400	7.99 26.67
3.0 m 10.0 ft	kg lb					*9400 *20,200	9350 20,200	*7400 *16,000	6150 13,300	*6450 *14,050	4450 9,600	*3900 *8,600	3800 8,350	8.36 27.50
1.5 m 5.0 ft	kg lb					*11 400 *24,550	8800 19,000	*8400 *18,150	5900 12,750	6650 14,300	4350 9,350	*4150 *9,100	3650 8,050	8.45 28.33
0 m 0 ft	kg lb			*6550 *15,000	*6550 *15,000	*12 500 *27,000	8500 18,350	9050 19,450	5750 12,350	6550 14,050	4250 9,150	*4600 *10,100	3750 8,200	8.26 27.50
-1.5 m -5.0 ft	kg lb	*7000 *15,600	*7000 *15,600	*11 350 *25,750	*11 350 *25,750	*12 600 *27,300	8450 18,150	8950 19,250	5650 12,150	6500 14,000	4200 9,100	*5400 *11,900	4050 8,850	7.78 25.83
-3.0 m -10.0 ft	kg lb	*12 000 *26,950	*12 000 *26,950	*16 750 *36,250	16 350 35,050	*11 800 *25,550	8500 18,300	*8750 *18,850	5700 12,250			*7000 *15,600	4700 10,450	6.95 23.33
-4.5 m -15.0 ft	kg lb			*13 350 *28,650	*13 350 *28,650	*9600 *20,450	8700 18,800					*7250 *15,950	6450 14,550	5.60 18.33



ISO 10567



*Indicates that the load is limited by hydraulic lifting capacity rather than tipping load. The above loads are in compliance with hydraulic excavator lift capacity standard ISO 10567:2007. They do not exceed 87% of hydraulic lifting capacity or 75% of tipping load. Weight of all lifting accessories must be deducted from the above lifting capacities. Lifting capacities are based on the machine standing on a firm, uniform supporting surface. The use of a work tool attachment point to handle/lift objects, could affect the machine lift performance.









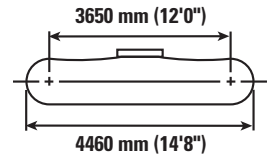
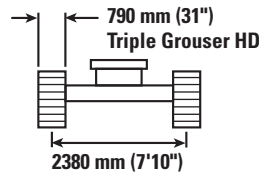
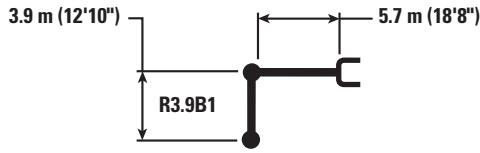





Lift capacity stays with ±5% for all available track shoes.

Always refer to the appropriate Operation and Maintenance Manual for specific product information.

323F L Hydraulic Excavator Specifications

HD Reach Boom Lift Capacities – Heavy Counterweight: 5.35 mt (11,700 lb) – without Bucket



		1.5 m/5.0 ft		3.0 m/10.0 ft		4.5 m/15.0 ft		6.0 m/20.0 ft		7.5 m/25.0 ft		9.0 m/30.0 ft				m ft-in
																
7.5 m 25.0 ft	kg lb													*3000 *6,600	*3000 *6,600	7.32 24.17
6.0 m 20.0 ft	kg lb									*4600 *9,600	*4600 *9,600			*2800 *6,150	*2800 *6,150	8.30 27.50
4.5 m 15.0 ft	kg lb									*5300 *11,650	4750 10,150			*2750 *6,050	*2750 *6,050	8.92 29.17
3.0 m 10.0 ft	kg lb					*7900 *17,000	*7900 *17,000	*6550 *14,200	6400 13,700	*5850 *12,750	4600 9,850	*3850 *7,150	3500 *7,150	*2800 *6,150	*2800 *6,150	9.25 30.83
1.5 m 5.0 ft	kg lb			*9800 *23,300	*9800 *23,300	*10 250 *22,050	9150 19,700	*7750 *16,750	6100 13,100	*6500 *14,100	4450 9,550	*4450 *8,500	3400 7,300	*2950 *6,450	*2950 *6,450	9.33 30.83
0 m 0 ft	kg lb			*8050 *18,450	*8050 *18,450	*11 950 *25,800	8700 18,750	*8700 *18,900	5850 12,600	6600 14,200	4300 9,250	*4150 *7,250	3350 7,200	*3200 *7,050	*3200 *7,050	9.16 30.00
-1.5 m -5.0 ft	kg lb	*6050 *13,500	*6050 *13,500	*10 400 *23,550	*10 400 *23,550	*12 700 *27,450	8500 18,300	9000 19,350	5700 12,300	6500 14,050	4250 9,100			*3650 *8,000	3450 7,650	8.73 29.17
-3.0 m -10.0 ft	kg lb	*9400 *21,050	*9400 *21,050	*14 400 *32,750	*14 400 *32,750	*12 500 *27,050	8500 18,250	8950 19,300	5650 12,200	6500 14,050	4200 9,100			*4450 *9,850	3900 8,600	8.00 26.67
-4.5 m -15.0 ft	kg lb	*13 650 *30,750	*13 650 *30,750	*16 250 *34,950	*16 250 *34,950	*11 300 *24,250	8600 18,500	*8300 *17,650	5750 12,400					*6150 *13,850	4850 10,800	6.87 22.50
-6.0 m	kg					*8050 *8050								*7100 *7100	*7100 *7100	4.91



ISO 10567



*Indicates that the load is limited by hydraulic lifting capacity rather than tipping load. The above loads are in compliance with hydraulic excavator lift capacity standard ISO 10567:2007. They do not exceed 87% of hydraulic lifting capacity or 75% of tipping load. Weight of all lifting accessories must be deducted from the above lifting capacities. Lifting capacities are based on the machine standing on a firm, uniform supporting surface. The use of a work tool attachment point to handle/lift objects, could affect the machine lift performance.

Lift capacity stays with ±5% for all available track shoes.

Always refer to the appropriate Operation and Maintenance Manual for specific product information.

232F L Hydraulic Excavator Specifications

Super Long Reach Boom Lift Capacities – Counterweight: 4.7 mt (10,360 lb) – without Bucket

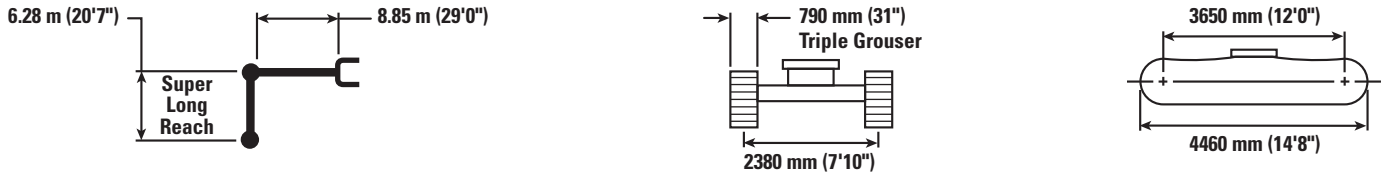

Reach m ft	kg lb	1.5 m/5.0 ft		3.0 m/10.0 ft		4.5 m/15.0 ft		6.0 m/20.0 ft		7.5 m/25.0 ft		m ft-in		
		kg lb	kg lb	kg lb	kg lb	kg lb	kg lb	kg lb	kg lb	kg lb	kg lb	kg lb	kg lb	
12.0 m 40.0 ft	kg lb											*1250 *2,800	*1250 *2,800	10.35 33.33
10.5 m 35.0 ft	kg lb											*1200 *2,600	*1200 *2,600	11.66 38.33
9.0 m 30.0 ft	kg lb											*1150 *2,450	*1150 *2,450	12.66 41.67
7.5 m 25.0 ft	kg lb											*1100 *2,400	*1100 *2,400	13.41 44.17
6.0 m 20.0 ft	kg lb											*1100 *2,400	*1100 *2,400	13.97 45.83
4.5 m 15.0 ft	kg lb											*1100 *2,400	*1100 *2,400	14.34 47.50
3.0 m 10.0 ft	kg lb			*4700 *11,850	*4700 *11,850	*5950 *12,700	*5950 *12,700	*4350 *9,400	*4350 *9,400	*3550 *7,650	*3550 *7,650	*1150 *2,500	*1150 *2,500	14.55 48.33
1.5 m 5.0 ft	kg lb					*6750 *15,750	*6750 *14,850	*5150 *11,050	4750 10,250	*4000 *8,700	3550 7,600	*1200 *2,600	*1200 *2,600	14.60 48.33
0 m 0 ft	kg lb			*2000 *4,550	*2000 *4,550	*4650 *10,700	*4650 *10,700	*5750 *12,400	4300 9,250	*4450 *9,550	3200 6,950	*1250 *2,750	1200 2,550	14.49 47.50
-1.5 m -5.0 ft	kg lb	*2050 *4,550	*2050 *4,550	*2700 *6,050	*2700 *6,050	*4650 *10,500	*4650 *10,500	*6100 *13,250	4000 8,600	*4700 *10,200	3000 6,450	*1350 *2,950	1200 2,600	14.23 46.67
-3.0 m -10.0 ft	kg lb	*2850 *6,350	*2850 *6,350	*3500 *7,850	*3500 *7,850	*5200 *11,750	*5200 *11,750	*6250 *13,550	3850 8,300	*4900 *10,550	2850 6,150	*1500 *3,300	1250 2,700	13.79 45.83
-4.5 m -15.0 ft	kg lb	*3650 *8,150	*3650 *8,150	*4400 *9,900	*4400 *9,900	*6050 *13,700	5800 12,400	*6250 *13,450	3800 8,200	*4900 *10,600	2800 6,050	*1700 *3,750	1350 2,900	13.17 43.33
-6.0 m -20.0 ft	kg lb	*4550 *10,100	*4550 *10,100	*5400 *12,150	*5400 *12,150	*7200 *16,350	5900 12,700	*6000 *12,900	3850 8,300	*4750 *10,250	2850 6,100	*2000 *4,450	1500 3,250	12.34 40.83
-7.5 m -25.0 ft	kg lb	*5500 *12,250	*5500 *12,250	*6550 *14,800	*6550 *14,800	*7100 *15,250	6100 13,150	*5500 *11,850	3950 8,550	*4450 *9,500	2900 6,250	*2500 *5,650	1750 3,850	11.24 36.67
-9.0 m -30.0 ft	kg lb			*7950 *16,950	*7950 *16,950	*5950 *12,700	*5950 *12,700	*4700 *10,050	4150 9,000	*3800 *8,050	3050 6,600	*2600 *5,700	2200 4,950	9.80 31.67



ISO 10567



*Indicates that the load is limited by hydraulic lifting capacity rather than tipping load. The above loads are in compliance with hydraulic excavator lift capacity standard ISO 10567:2007. They do not exceed 87% of hydraulic lifting capacity or 75% of tipping load. Weight of all lifting accessories must be deducted from the above lifting capacities. Lifting capacities are based on the machine standing on a firm, uniform supporting surface. The use of a work tool attachment point to handle/lift objects, could affect the machine lift performance.









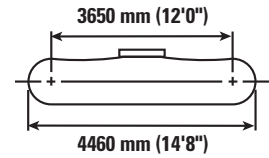
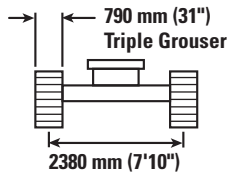
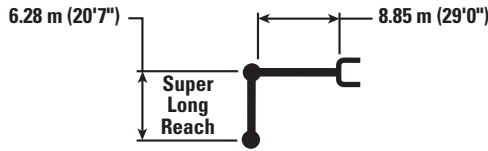

Lift capacity stays with ±5% for all available track shoes.

Always refer to the appropriate Operation and Maintenance Manual for specific product information.

323F L Hydraulic Excavator Specifications

Super Long Reach Boom Lift Capacities – Counterweight: 4.7 mt (10,360 lb) – without Bucket



		9.0 m/30.0 ft		10.5 m/35.0 ft		12.0 m/40.0 ft		13.5 m/45.0 ft				m ft-in
												
12.0 m 40.0 ft	kg lb									*1250 *2,800	*1250 *2,800	10.35 33.33
10.5 m 35.0 ft	kg lb			*2150 *4,700	*2150 *4,700					*1200 *2,600	*1200 *2,600	11.66 38.33
9.0 m 30.0 ft	kg lb			*2150 *4,700	*2150 *4,700	*2000 *3,650	*2000 *3,650			*1150 *2,450	*1150 *2,450	12.66 41.67
7.5 m 25.0 ft	kg lb			*2200 *4,850	*2200 *4,850	*2150 *4,750	2050 4,400			*1100 *2,400	*1100 *2,400	13.41 44.17
6.0 m 20.0 ft	kg lb			*2350 *5,100	*2350 *5,100	*2250 *4,900	2000 4,250	*1850 *3,250	1550 *3,250	*1100 *2,400	*1100 *2,400	13.97 45.83
4.5 m 15.0 ft	kg lb	*2750 *5,950	*2750 *5,950	*2500 *5,450	2450 5,250	*2350 *5,100	1900 4,100	*2250 *4,600	1500 3,200	*1100 *2,400	*1100 *2,400	14.34 47.50
3.0 m 10.0 ft	kg lb	*3050 *6,600	2950 6,350	*2700 *5,900	2300 4,950	*2500 *5,400	1850 3,900	*2300 *5,050	1450 3,100	*1150 *2,500	*1150 *2,500	14.55 48.33
1.5 m 5.0 ft	kg lb	*3350 *7,250	2700 5,850	*2900 *6,300	2150 4,600	*2600 *5,700	1750 3,700	2350 5,050	1400 2,950	*1200 *2,600	*1200 *2,600	14.60 48.33
0 m 0 ft	kg lb	*3650 *7,850	2500 5,400	*3100 *6,750	2000 4,300	2750 5,900	1650 3,500	2300 4,900	1350 2,850	*1250 *2,750	1200 2,550	14.49 47.50
-1.5 m -5.0 ft	kg lb	*3850 *8,300	2350 5,050	3250 6,900	1900 4,050	2650 5,700	1550 3,300	2250 4,800	1300 2,750	*1350 *2,950	1200 2,600	14.23 46.67
-3.0 m -10.0 ft	kg lb	3900 8,350	2250 4,850	3150 6,750	1850 3,900	2600 5,600	1500 3,200	2250 *3,650	1250 2,700	*1500 *3,300	1250 2,700	13.79 45.83
-4.5 m -15.0 ft	kg lb	3850 8,250	2200 4,750	3100 6,700	1800 3,850	2600 5,600	1500 3,200			*1700 *3,750	1350 2,900	13.17 43.33
-6.0 m -20.0 ft	kg lb	3850 8,250	2200 4,750	3100 6,700	1800 3,850	2650 *5,150	1550 3,300			*2000 *4,450	1500 3,250	12.34 40.83
-7.5 m -25.0 ft	kg lb	*3650 *7,750	2250 4,900	*2950 *6,250	1850 4,050					*2500 *5,650	1750 3,850	11.24 36.67
-9.0 m -30.0 ft	kg lb	*3050 *6,300	2400 5,250							*2600 *5,700	2200 4,950	9.80 31.67



ISO 10567



*Indicates that the load is limited by hydraulic lifting capacity rather than tipping load. The above loads are in compliance with hydraulic excavator lift capacity standard ISO 10567:2007. They do not exceed 87% of hydraulic lifting capacity or 75% of tipping load. Weight of all lifting accessories must be deducted from the above lifting capacities. Lifting capacities are based on the machine standing on a firm, uniform supporting surface. The use of a work tool attachment point to handle/lift objects, could affect the machine lift performance.

Lift capacity stays with ±5% for all available track shoes.

Always refer to the appropriate Operation and Maintenance Manual for specific product information.

323F L Hydraulic Excavator Specifications

Work Tool Offering Guide*

Boom Type	Standard Configuration HD Reach Boom		Heavy Counterweight Configuration HD Reach Boom	
	HD R2.9 (9'6")	HD R2.9 (9'6")	HD R2.9 (9'6") – Thumb Ready	HD R3.9 (12'10")
Hydraulic Hammer	H120Es H130Es	H120Es H130Es	H120Es H130Es	H120Es** H130Es***
Multi-Processor	MP318 CC Jaw MP318 D Jaw MP318 P Jaw** MP318 U Jaw MP318 S Jaw	MP318 CC Jaw MP318 D Jaw MP318 P Jaw** MP318 U Jaw MP318 S Jaw	MP318 CC Jaw MP318 D Jaw MP318 P Jaw** MP318 U Jaw** MP318 S Jaw	MP318 S Jaw***
Crusher	P315	P315	P315	
Pulverizer	P215	P215	P215	P215***
Demolition and Sorting Grapple	G315B-D G315B-R	G315B-D G315B-R	G315B-D G315B-R	
Mobile Scrap and Demolition Shear	S320B** S325B# S340B#	S320B** S325B# S340B#	S320B*** S325B# S340B#	S325B# S340B#
Compactor (Vibratory Plate)	CVP110	CVP110	CVP110	CVP110
Orange Peel Grapple				
Trash Grapple				
Thumbs				
Rakes				
Center-Lock™ Pin Grabber Coupler				
Dedicated Quick Coupler				

These work tools are available for the 323F L.
Consult your Cat dealer for proper match.

*Offerings not available in all areas. Matches are dependent on excavator configurations. Consult your Cat dealer to determine what is offered in your area and for proper work tool match.

**Pin-on or dedicated coupler.

***Pin-on only.

#Boom Mount.

323F L Hydraulic Excavator Specifications

Bucket Specifications and Compatibility

	Linkage	Width		Capacity		Weight		Fill %	Standard Configuration R2.9 (9'6")	Heavy Counterweight Configuration			Super Long Reach Configuration 6.28 m (20'7")
		mm	in	m ³	yd ³	kg	lb			R2.9 (9'6")	R2.9 (9'6") - Thumb Ready	R3.9 (12'10")	
Without Quick Coupler													
General Duty (GDC)	B	600	24	0.55	0.72	618	1,363	100%	●	●	●	●	
	B	750	30	0.75	0.98	710	1,566	100%	●	●	●	●	
	B	900	36	0.95	1.24	786	1,733	100%	●	●	●	●	
	B	1050	42	1.16	1.52	847	1,867	100%	●	●	●	●	
	B	1200	48	1.38	1.80	925	2,038	100%	⊙	●	●	⊙	
	B	1350	54	1.59	2.08	1002	2,209	100%	⊖*	⊙*	⊙*	X	
Heavy Duty (HD)	B	600	24	0.46	0.61	649	1,430	100%	●	●	●	●	
	B	750	30	0.64	0.84	747	1,647	100%	●	●	●	●	
	B	900	36	0.81	1.06	825	1,818	100%	●	●	●	●	
	B	1050	42	1.00	1.31	879	1,937	100%	●	●	●	●	
	B	1200	48	1.19	1.56	970	2,138	100%	●	●	●	⊙	
	B	1350	54	1.38	1.81	1051	2,316	100%	⊖*	●*	⊙*	X	
Severe Duty (SD)	B	600	24	0.46	0.61	693	1,527	90%	●	●	●	●	
	B	750	30	0.64	0.84	801	1,765	90%	●	●	●	●	
	B	900	36	0.81	1.06	887	1,955	90%	●	●	●	●	
	B	1050	42	1.00	1.31	962	2,121	90%	●	●	●	●	
	B	1200	48	1.19	1.56	1051	2,316	90%	●	●	●	●	
General Duty (GD)	A	900	36	0.53	0.69	403	888	100%					◇
Ditch Cleaning (DC)	A	1200	48	0.57	0.74	388	855	100%					◇
Maximum load pin-on (payload + bucket)								kg	3391	3974	3754	3279	969
								lb	7,474	8,759	8,274	7,227	2,136
With Pin Grabber Coupler													
General Duty (GDC)	B	600	24	0.55	0.72	618	1,363	100%	●	●	●	●	
	B	750	30	0.75	0.98	710	1,566	100%	●	●	●	●	
	B	900	36	0.95	1.24	786	1,733	100%	●	●	●	●	
	B	1050	42	1.16	1.52	847	1,867	100%	⊙	●	●	⊙	
	B	1200	48	1.38	1.80	925	2,038	100%	⊖	⊙	⊙	○	
	B	1350	54	1.59	2.08	1002	2,209	100%	○	⊖	⊖	○	
Heavy Duty (HD)	B	600	24	0.46	0.61	649	1,430	100%	●	●	●	●	
	B	750	30	0.64	0.84	747	1,647	100%	●	●	●	●	
	B	900	36	0.81	1.06	825	1,818	100%	●	●	●	●	
	B	1050	42	1.00	1.31	879	1,937	100%	●	●	●	⊙	
	B	1200	48	1.19	1.56	970	2,138	100%	⊖	●	⊙	⊖	
	B	1350	54	1.38	1.81	1051	2,316	100%	○	⊙	⊖	○	
Severe Duty (SD)	B	600	24	0.46	0.61	693	1,527	90%	●	●	●	●	
	B	750	30	0.64	0.84	801	1,765	90%	●	●	●	●	
	B	900	36	0.81	1.06	887	1,955	90%	●	●	●	●	
	B	1050	42	1.00	1.31	962	2,121	90%	●	●	●	●	
	B	1200	48	1.19	1.56	1051	2,316	90%	⊙	●	●	⊖	
Maximum load with coupler (payload + bucket)								kg	2981	3564	3344	2869	
								lb	6,571	7,856	7,371	6,324	

The above loads are in compliance with hydraulic excavator standard EN474, they do not exceed 87% of hydraulic lifting capacity or 75% of tipping capacity with front linkage fully extended at ground line with bucket curled.

Capacity based on ISO 7451.

Bucket weight with General Duty tips.

*For light dirt loading applications only. Consult your dealer to understand your application before using this bucket in combination with this stick.

Maximum Material Density:

- 2100 kg/m³ (3,500 lb/yd³)
- ⊙ 1800 kg/m³ (3,000 lb/yd³)
- ⊖ 1500 kg/m³ (2,500 lb/yd³)
- 1200 kg/m³ (2,000 lb/yd³)
- ◇ 900 kg/m³ (1,500 lb/yd³)
- X Not Recommended

Caterpillar recommends using appropriate work tools to maximize the value customers receive from our products. Use of work tools, including buckets, which are outside of Caterpillar's recommendations or specifications for weight, dimensions, flows, pressures, etc. may result in less-than-optimal performance, including but not limited to reductions in production, stability, reliability, and component durability. Improper use of a work tool resulting in sweeping, prying, twisting and/or catching of heavy loads will reduce the life of the boom and stick.

323F L Standard Equipment

Standard Equipment

Standard equipment may vary. Consult your Cat dealer for details.

ENGINE

- C7.1 ACERT certified to Tier 4 Final emission standards
- Three selectable power modes
 - HP, STD and ECO
- Variable-speed fan with viscous clutch
- One-touch low idle with automatic engine speed control
- Automatic engine idle shutdown
- Three-stage fuel filtration system with water separator and indicator
- 4600 m (15,090 ft) altitude capability with derate from 3000 m (9,840 ft)
- 52° C (126° F) high-ambient cooling capacity with derate from 48° C (118° F)
- 115 amp alternator
- Radial seal air filter with double filter element
- Electric fuel priming pump
- Capability of using biodiesel fuel (B20)
- Starting kit for –18° C (0° F)

HYDRAULICS

- Electric boom regeneration circuit
- Stick regeneration circuit
- One-touch lifting mode
- Automatic two-speed travel
- Boom and stick drift reduction valve
- Reverse swing damping valve
- High-performance hydraulic return filter
- Canada compliant accumulator
- Fine swing control

CAB

- Sound suppressed ROPS cab with viscous mount
- Openable skylight as emergency exit
- Openable laminated front upper windshield with assist device
- Removable tempered lower windshield with in-cab storage bracket
- High back seat with air suspension, seat heater and head rest
- Fully adjustable seat, console and armrest
- 51 mm (2 in) width seat belt
- Full graphic 7 inch LCD monitor with distortion-free rearview camera picture
- Automatic bi-level air conditioner with pressurized function
- Joystick with modulation switch (one modulation switch and three on/off switches per one joystick)
- Radial wiper
- 24V AM/FM radio (includes auxiliary input)
- 24V radio ready with stereo speakers and flexible antenna
- 12V × 2 power supply with sockets (maximum 10 amp)
- Washable floor mat
- Interior utilities
 - Interior lighting
 - Coat hook
 - Beverage holder
 - Literature holder
 - Document holding space
 - Cab rear storage compartment
- Sun screen roll type for 70/30 window
- Straight travel pedal

UNDERCARRIAGE & STRUCTURES

- HD track rollers
- Segmented (two-piece) track guiding guard
- Grease lubricated track link
- Tie down points on base frame
- HD bottom guard
- Swivel guard

ELECTRICAL

- Maintenance-free battery
- Centralized electrical disconnect switch
- Cat Product Link
- Programmable time-delay halogen working lights
 - Storage box mounted (one)
 - Cab mounted (two)
 - Boom mounted LH and RH (two)

TECHNOLOGY

- Cat Grade Control Depth and Slope*

SERVICE & MAINTENANCE

- Engine oil, fuel, and hydraulic oil filters grouped for ease of maintenance
- Sampling ports for Scheduled Oil Sampling (S-O-SSM)
- Tilt-up air-to-air aftercooler (ATAAC) and swing-out type A/C condenser for easy maintenance

SAFETY & SECURITY

- Rearview camera with three mirrors and one additional cab mirror
- RH hand rail and hand hold
- Bolt-free service platform with anti-skid plate
- Neutral lever (lock out) for all controls
- Ground-level accessible secondary engine shutoff switch in cab
- Signaling/warning horn
- Safety hammer for cab evacuation
- Travel alarm

* Standard on R2.9 (9'6") sticks; optional on other lengths.

Optional Equipment

Optional equipment may vary. Consult your Cat dealer for details.

ENGINE

- -32° C (-26° F) with jump start receptacle
- Air precleaner

HYDRAULICS

- Tool control
- Medium-pressure circuit
- Quick coupler circuit for Cat Pin Grabber

CAB

- Control pattern quick changer
- 75 mm (3 in) width seat belt, if necessary

UNDERCARRIAGE & STRUCTURES

- 4100 kg (9,040 lb) standard counterweight
- 4700 kg (10,360 lb) extra counterweight for Super Long Reach
- 5350 kg (11,700 lb) for heavy configuration
- 600 mm (24 in) single grouser shoe
- 790 mm (31 in) triple grouser shoe
- 790 mm (31 in) triple grouser heavy-duty shoe
- HD 5.7 m (18'8") boom
- HD Reach 5.7 m (18'8") boom, Heavy Counterweight Configuration
- Super Long Reach 8.85 m (29'0") boom
- 3.9 m (12'10") stick
- 2.9 m (9'6") stick
- Thumb-ready 2.9 m (9'6") stick
- Super Long Reach 6.28 m (20'7") stick
- Bucket linkage

SERVICE & MAINTENANCE

- PM (Preventative Maintenance) ready (QuickEvac)

SAFETY & SECURITY

- FOGS (bolt-on)
- Vandalism guard
- Boom lowering control device and stick lowering check valve
- Rubber bumper

TECHNOLOGY

- GRADE with ASSIST

For more complete information on Cat products, dealer services, and industry solutions, visit us on the web at www.cat.com

© 2015 Caterpillar
All rights reserved

Materials and specifications are subject to change without notice. Featured machines in photos may include additional equipment. See your Cat dealer for available options.

CAT, CATERPILLAR, SAFETY.CAT.COM, their respective logos, "Caterpillar Yellow" and the "Power Edge" trade dress, as well as corporate and product identity used herein, are trademarks of Caterpillar and may not be used without permission.

VisionLink is a trademark of Trimble Navigation Limited, registered in the United States and in other countries.

AEHQ7357-02 (11-2015)
Replaces AEHQ7357-01
(North America)



Courtesy of Machine.Market