

SAFETY.CAT.COM™

420E, 430E, 432E, 434E, 442E, AND 444E BACKHOE LOADERS

Maintenance Intervals

Excerpted from Operation & Maintenance Manual (SEBU7687-08)

i03740480

Maintenance Interval Schedule

SMCS Code: 7000

Ensure that all safety information, warnings and instructions are read and understood before any operation or any maintenance procedures are performed.

The user is responsible for the performance of maintenance, including all adjustments, the use of proper lubricants, fluids, filters, and the replacement of components due to normal wear and aging. Failure to adhere to proper maintenance intervals and procedures may result in diminished performance of the product and/or accelerated wear of components.

Use mileage, fuel consumption, service hours, or calendar time, WHICH EVER OCCURS FIRST, in order to determine the maintenance intervals. Products that operate in severe operating conditions may require more frequent maintenance.

Note: Before each consecutive interval is performed, all maintenance from the previous interval must be performed.

Note: If Cat HYDO Advanced 10 hydraulic oil is used, the hydraulic oil change interval will change. The normal interval of 2000 hours is extended to 3000 hours. S·O·S services may extend the oil change even longer. Consult your Caterpillar dealer for details.

When Required

Battery - Recycle	146
Battery or Battery Cable - Inspect/Replace	146
Bucket Cutting Edges - Inspect/Replace	148
Bucket Tips - Inspect/Replace	149
Cab Interior - Clean	151
Engine Air Filter Primary Element - Clean/ Replace	158
Engine Air Filter Secondary Element - Replace ..	159
Engine Air Precleaner - Clean	160
Engine Compartment - Clean	160
Fuses - Replace	172
Oil Filter - Inspect	178
Radiator Core - Clean	180
Window Washer Reservoir - Fill	188
Window Wipers - Inspect/Replace	188
Windows - Clean	188

Every 10 Service Hours or Daily

Backhoe Boom, Stick, Bucket, and Cylinder Bearings - Lubricate	145
Backup Alarm - Test	146
Braking System - Test	148
Cooling System Coolant Level - Check	153

Engine Air Filter Service Indicator - Inspect	160
Engine Oil Level - Check	161
Fuel System Water Separator - Drain	171
Hydraulic System Oil Level - Check	176
Loader Bucket, Cylinder, and Linkage Bearings - Lubricate	176
Seat Belt - Inspect	181
Stabilizer - Clean/Inspect	182
Stabilizer and Cylinder Bearings - Lubricate	183
Swing Frame and Cylinder Bearings - Lubricate ..	183
Tire Inflation - Check	183
Transmission Oil Level - Check	186
Wheel Nut Torque - Check	188

Every 50 Service Hours or Weekly

Cab Filter (Fresh Air) - Clean/Inspect/Replace ...	150
Cab Filter (Recirculation) - Clean/Inspect/ Replace	151
Fuel Tank Water and Sediment - Drain	171
Parking Brake - Check/Adjust	178

Every 250 Service Hours

Engine Oil Sample - Obtain	162
----------------------------------	-----

Every 250 Service Hours or Monthly

Axle Breathers - Clean/Replace	145
Belts - Inspect/Adjust/Replace	147
Differential Oil Level (Front) - Check	156
Differential Oil Level (Rear) - Check	156
Extendable Stick Pads - Inspect/Adjust	163
Final Drive Oil Level (Front) - Check	168
Final Drive Oil Level (Rear) - Check	169
Power Sideshift Stabilizer Wear Pads - Inspect ..	179
Sideshift Stabilizer Wear Pads - Inspect/Adjust ..	182

Initial 500 Hours (for New Systems, Refilled Systems, and Converted Systems)

Cooling System Coolant Sample (Level 2) - Obtain	154
---	-----

Every 500 Service Hours or 3 Months

Cooling System Coolant Sample (Level 1) - Obtain	153
Differential Oil Sample (Front) - Obtain	157
Differential Oil Sample (Rear) - Obtain	157
Drive Shaft Spline - Lubricate	157
Engine Oil and Filter - Change	162
Final Drive Oil Sample (Front) - Obtain	169
Final Drive Oil Sample (Rear) - Obtain	169
Fuel System Filter and Water Separator - Replace	169
Fuel System Secondary Filter - Replace	170
Hydraulic Oil Sample - Obtain	173
Hydraulic System Oil Filter - Replace	175
Transmission Oil Filter - Replace	185
Transmission Oil Sample - Obtain	187

Every 1000 Service Hours

Engine Valve Lash - Check 163

Every 1000 Service Hours or 6 Months

Differential Oil (Front) - Change 155
Differential Oil (Rear) - Change 156
Final Drive Oil (Front) - Change 167
Final Drive Oil (Rear) - Change 168
Rollover Protective Structure (ROPS) - Inspect .. 181
Transmission Magnetic Screen - Clean 184
Transmission Oil - Change 184
Wheel Bearings (Front) - Lubricate 187

Every 2000 Service Hours

Engine Crankcase Breather - Replace 161

Every 2000 Service Hours or 1 Year

Hydraulic System Oil - Change 174
Receiver Dryer (Refrigerant) - Replace 180

Every Year

Cooling System Coolant Sample (Level 2) -
Obtain 154

Every 3000 Service Hours or 2 Years

Cooling System Water Temperature Regulator -
Clean/Replace 155

**Every 3 Years After Date of Installation or
Every 5 Years After Date of Manufacture**

Seat Belt - Replace 181

Every 6000 Service Hours or 3 Years

Cooling System Coolant Extender (ELC) - Add .. 153

Every 12 000 Service Hours or 6 Years

Cooling System Coolant (ELC) - Change 151

i02436158

Axle Breathers - Clean/Replace

SMCS Code: 3278-070-BRE; 3278-510-BRE

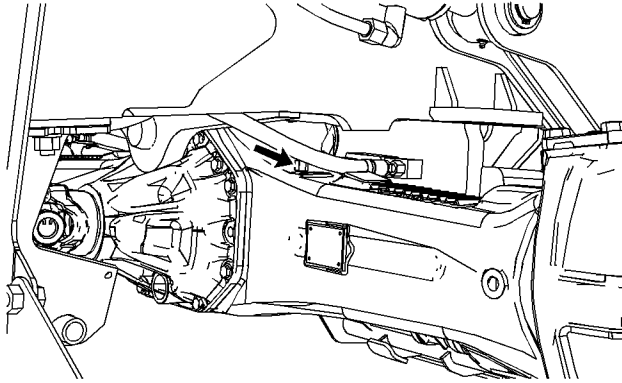

Illustration 210

g01216797

The front axle breather is located on the top right side of the differential housing.

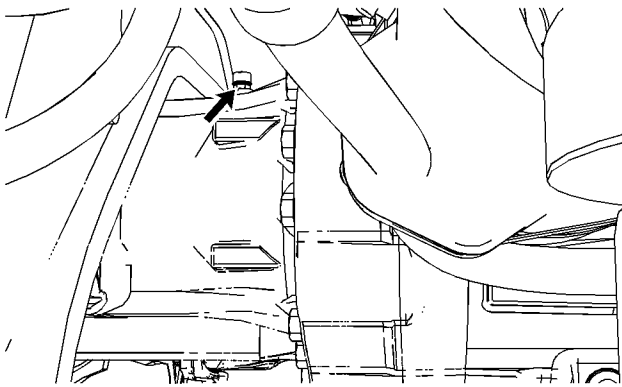

Illustration 211

g01216798

The rear axle breather is located to the left of the differential housing.

1. Clean the area around the breathers. Remove the breather from the front axle.
2. Wash the breather in clean nonflammable solvent. Wipe the breather dry and check the breather for damage.
3. Install the clean breather back into the axle. Replace the breather if the breather is damaged.

Note: Make sure that the slot in the breather is parallel to the axle housing.

i02968284

Backhoe Boom, Stick, Bucket, and Cylinder Bearings - Lubricate

SMCS Code: 6501-086-BD; 6502-086-BD;
6503-086-BD; 6511-086-BD; 6512-086-BD;
6533-086-BD; 7562-086-BD

Illustration 212

g01194613

Position the backhoe into the service position that is shown above. Lower the bucket to the ground. Relieve the hydraulic pressure.

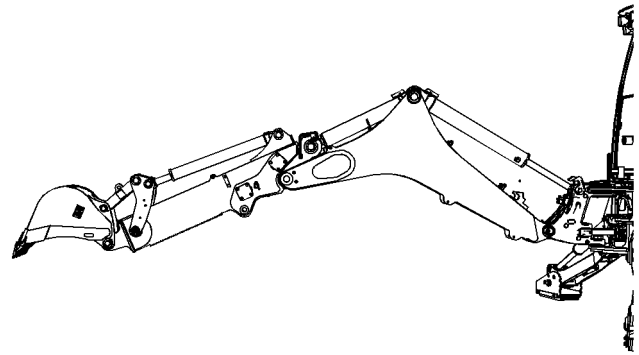
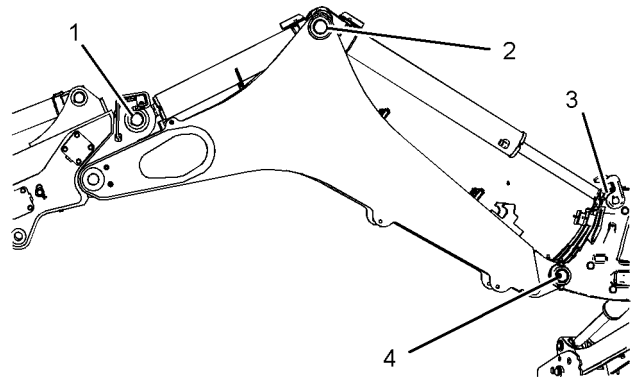

Illustration 213

g01194615

Apply lubricant to the grease fitting (1) for the rod end of the stick cylinder.

Apply lubricant to the grease fitting (2) for the head end of the boom cylinder and the head end of the stick cylinder.

Apply lubricant to the grease fitting (3) for the rod end of the boom cylinder.

Apply lubricant to the grease fitting (4) for the boom pivot. There is one grease fitting on each side of the machine.

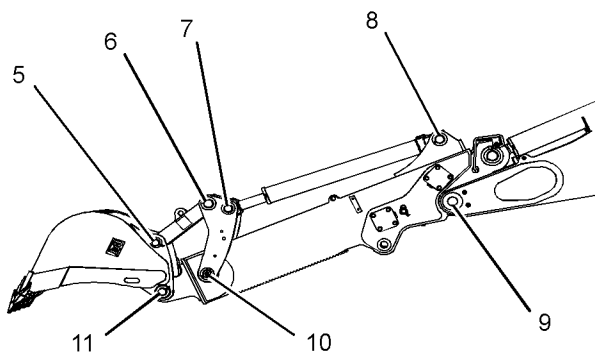

Illustration 214

g01194617

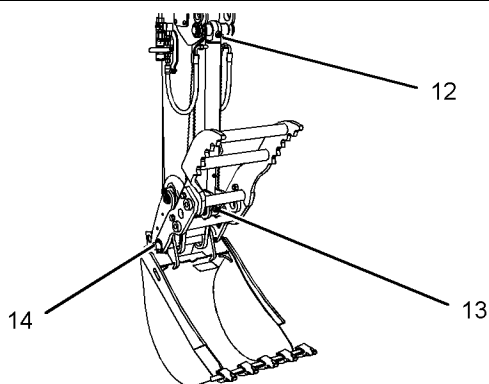

Illustration 215

g01491621

Apply lubricant to the grease fitting (5) for the bucket pivot pin.

Apply lubricant to the grease fitting (6) for the link.

Apply lubricant to the grease fitting (7) for the rod end of the bucket cylinder.

Apply lubricant to the grease fitting (8) for the head end of the bucket cylinder.

Apply lubricant to the grease fitting (9) for the pivot pin for the stick.

Apply lubricant to the grease fitting (10) for the pivot pin. There is one grease fitting on each side of the machine.

Apply lubricant to the grease fitting (11) for the pivot pin.

Apply lubricant to the grease fitting (12) for the head end of the thumb cylinder.

Apply lubricant to the grease fitting (13) for the rod end of the thumb cylinder.

Apply lubricant to the grease fitting (14) for the pivot pin on each side of the thumb.

There is a total of 21 grease fittings.

i00080741

Backup Alarm - Test

SMCS Code: 7406

Turn the engine start switch key to ON in order to perform the test.

Apply the service brake. Move the transmission direction control lever to REVERSE position.

The backup alarm should immediately sound. The backup alarm will continue to sound until the transmission direction control lever is moved to the NEUTRAL position or to the FORWARD position.

i00993589

Battery - Recycle

SMCS Code: 1401-561

Always recycle a battery. Never discard a battery.

Always return used batteries to one of the following locations:

- A battery supplier
- An authorized battery collection facility
- Recycling facility

i01833495

Battery or Battery Cable - Inspect/Replace

SMCS Code: 1401

1. Turn the engine start switch to the OFF position. Turn all switches to the OFF position.

2. Disconnect the negative battery cable from the frame.

Note: Do not allow the disconnected battery cable to contact the frame of the machine.

3. Disconnect the negative battery cable at the battery.

4. Inspect the battery terminals and inspect the battery cables. Keep the terminals clean and keep the terminals coated with petroleum jelly.

5. Perform the necessary repairs. Replace the cable or the battery, as needed.
6. Connect the negative battery cable at the battery.
7. Connect the battery cable to the frame of the machine.
8. Install the engine start switch key.

i03316203

Belts - Inspect/Adjust/Replace

SMCS Code: 1357-025; 1357-040; 1357-510

If new belts are installed, check belt adjustment after 30 minutes of operation. For multiple belt drive applications, always replace the belts in matched sets. Replacing only one belt of a matched set will cause the new belt to carry more load because the older belts are stretched. The additional load on the new belt could cause the new belt to break.

1. Install the lift cylinder brace. Refer to Operation and Maintenance Manual, "Lift Cylinder Brace - Connect and Disconnect" for more information.
2. Remove the engine access panel on the left side of the machine.

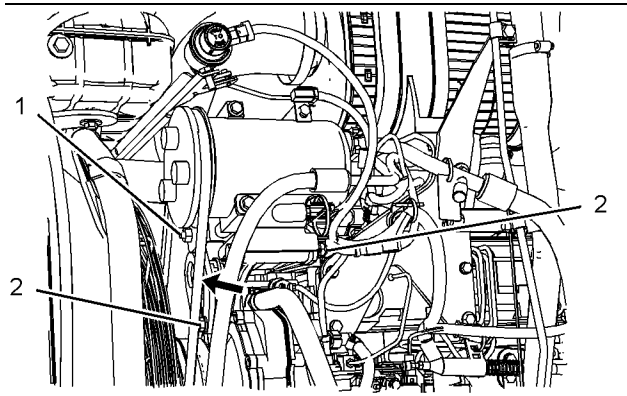

Illustration 216

g01178773

3. Inspect the condition of the air conditioner belt and the adjustment of the air conditioner belt. The air conditioner belt should deflect 10 mm (0.38 inch) under 110 N (25 lb) of force.
4. Loosen the adjusting locknut (1). Loosen the two compressor bracket mounting bolts (2).
5. Move the compressor until the correct belt tension is reached.
6. Tighten the adjusting locknut (1). Tighten the two compressor bracket mounting bolts (2).

7. Recheck the belt deflection. If the amount of deflection is incorrect, repeat Step 4 to Step 6.
8. Install the engine access panel.
9. Remove the engine access panel on the right side of the machine.

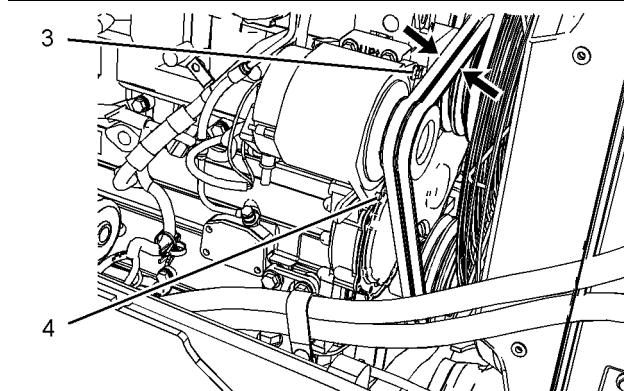

Illustration 217

g01178833

10. Inspect the condition of the alternator belts and the adjustment of the alternator belts. The alternator belts should deflect 10 mm (0.38 inch) under 110 N (25 lb) of force.
11. Loosen the mounting bolt (3). Loosen the adjusting locknut (4).
12. Move the alternator until the correct tension is reached.
13. Tighten the adjusting locknut (4). Tighten the mounting bolt (3).
14. Recheck the belt deflection. If the amount of deflection is incorrect, repeat Step 11 to Step 13.
15. Install the engine access panel.
16. Start the engine. Raise the loader arms to the maximum height.
17. Remove the pin and replace the brace for the loader lift arm to the stored position on the loader lift arm.
18. Lower the bucket to the ground.

i00651426

Braking System - Test

SMCS Code: 4251; 4267; 7000

Service Brake Holding Ability Test

Check the area around the machine. Make sure that the machine is clear of personnel and clear of obstacles.

Test the brakes on a dry, level surface.

Fasten the seat belt before you test the brakes.

The following tests are used to determine if the service brake is functional. These tests are not intended to measure the maximum brake holding effort. The brake holding effort that is required to sustain a machine at a specific engine rpm varies depending on the machine. The variations are the differences in the engine setting, in the power train efficiency, and in the brake holding ability, etc.

1. Start the engine. Raise the bucket slightly.
2. Apply the service brake. Release the parking brake.
3. Move the transmission control lever to THIRD SPEED FORWARD.
4. Gradually increase the engine speed to high idle. The machine should not move.

WARNING

If the machine begins to move, reduce the engine speed immediately and engage the parking brake.

5. Reduce the engine speed to low idle. Move the transmission to NEUTRAL. Engage the parking brake. Lower the bucket to the ground. Stop the engine.

NOTICE

If the machine moved while testing the brakes, contact your Caterpillar dealer. Have the dealer inspect and, if necessary, repair the service brake before returning the machine to operation.

Secondary Brake Holding Ability Test

Check the area around the machine. Make sure that the machine is clear of personnel and clear of obstacles.

Test the brakes on a dry, level surface.

Fasten the seat belt before you test the brakes.

The following tests are used to determine if the parking brake is functional. These tests are not intended to measure the maximum brake holding effort. The brake holding effort that is required to sustain a machine at a specific engine rpm varies depending on the machine. The variations are the differences in the engine setting, in the power train efficiency, and in the brake holding ability, etc.

1. Start the engine. Raise the bucket slightly.
2. Engage the parking brake.
3. Move the transmission control lever to THIRD SPEED FORWARD.

Note: The parking brake indicator light should come on and the parking brake alarm should sound.

4. Gradually increase the engine speed to high idle. The machine should not move.

WARNING

If the machine begins to move, reduce the engine speed immediately and apply the service brake pedal.

5. Reduce the engine speed. Move the transmission to NEUTRAL. Lower the bucket to the ground. Stop the engine.

NOTICE

If the machine moved while testing the brakes, contact your Caterpillar dealer.

Have the dealer inspect and, if necessary, repair the parking brakes before returning the machine to operation.

i01920076

Bucket Cutting Edges - Inspect/Replace

SMCS Code: 6801

WARNING

Personal injury or death can result from bucket falling.

Block the bucket before changing bucket cutting edges.

1. Raise the bucket. Place a block under the bucket.
2. Lower the bucket to the blocking.

Do not block up the bucket too high. Block up the bucket so that the bucket is high enough to remove the cutting edges and the end bits.

3. Remove the bolts. Remove the cutting edge and the end bits.
4. Clean the contact surfaces.
5. Use the opposite side of the cutting edge, if this side is not worn.
6. Install a new cutting edge, if both edges are worn.
7. Install the bolts. Tighten the bolts to the specified torque.
8. Raise the bucket. Remove the blocks.
9. Lower the bucket to the ground.
10. After a few hours of operation, check the bolts for proper torque.

i02540747

Bucket Tips - Inspect/Replace

SMCS Code: 6805

WARNING

Personal injury or death can result from the bucket falling.

Block the bucket before changing bucket tips.

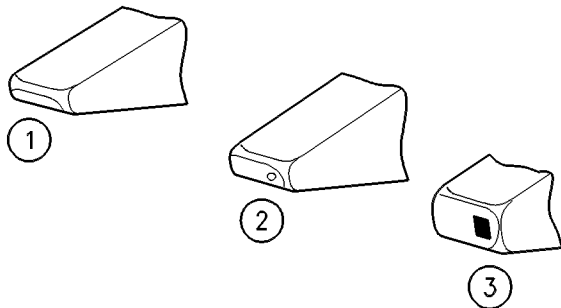

Illustration 218

g00101352

(1) This tip is usable. (2) This tip should be replaced. (3) This tip has been overworn.

Check the bucket tips for wear. If the bucket tip has a hole, replace the bucket tip.

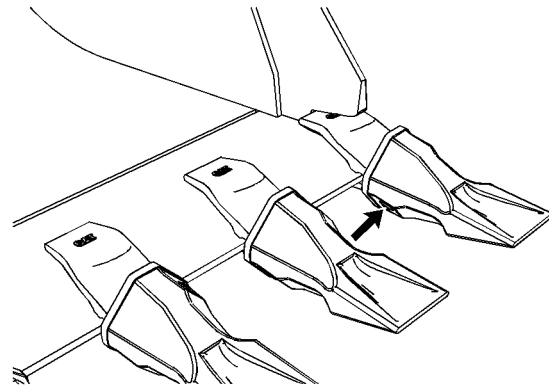

Illustration 219

g01272671

1. Drive the pin out of the bucket tip from the retainer side of the bucket tip. Remove the bucket tip and the retainer.

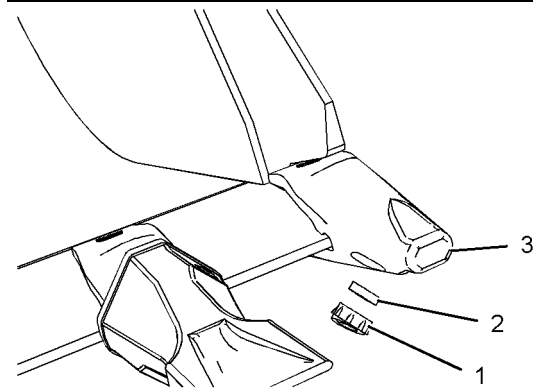

Illustration 220

g01272854

- (1) Retaining washer
- (2) Retainer
- (3) Adapter

2. Clean the adapter and the pin.
3. Fit retainer (2) into retaining washer (1). Install this assembly into the groove that is in the side of adapter (3).

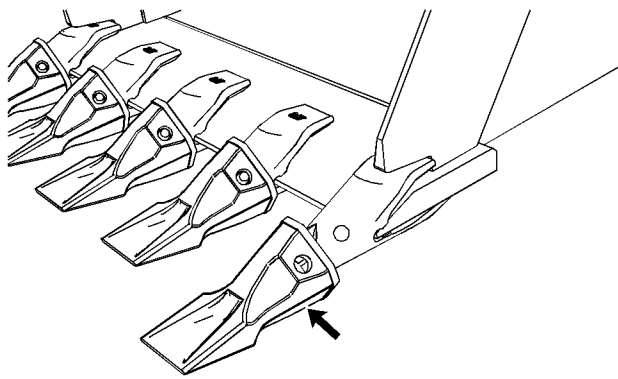

Illustration 221

g01272859

4. Install the new bucket tip or the rotated bucket tip onto the adapter. To allow greater penetration or less penetration, the bucket tip may be rotated by 180 degrees.
5. From the other side of the retainer, drive the pin through the bucket tip, the adapter, and the retainer.
6. After you drive the pin, make sure that the retainer fits snugly into the pin groove.

i02502577

Cab Filter (Fresh Air) - Clean/Inspect/Replace

SMCS Code: 7342-040; 7342-070; 7342-510

NOTICE

Do not clean the elements by bumping or tapping them.

Inspect the elements after cleaning. Do not use an element with damaged pleats, gaskets or seals.

When cleaning with pressure air, use 205 kPa (30 psi) maximum to prevent element damage by too much air pressure.

When cleaning with pressure water, use 280 kPa (40 psi) maximum to prevent element damage.

Clean the filter element weekly, but clean the filter element daily when there is a reduction of air circulation.

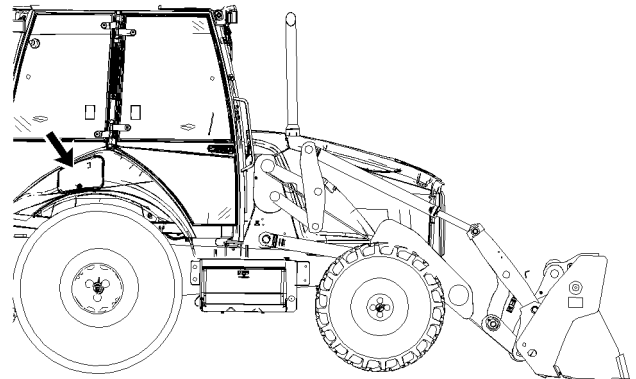

Illustration 222

g01257728

1. Open the filter cover that is located on the right fender.

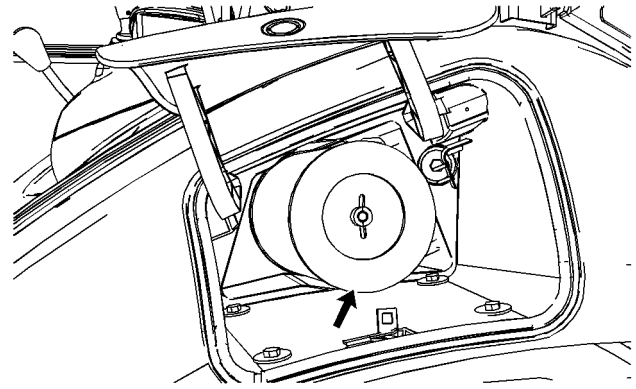

Illustration 223

g01200815

2. Remove the filter element.
3. Clean the filter element with compressed air or pressure water. Direct the air or the water along the pleats of the element. You can also wash the element with clean water and nonsudsing household detergent.
4. Rinse the filter element thoroughly with clear water.
5. Allow the filter element to air dry. Inspect the element for damage. If the filter element is damaged, replace the filter element.
6. Install the filter element.
7. Install the filter cover.

i02502545

i02510458

Cab Filter (Recirculation) - Clean/Inspect/Replace

SMCS Code: 7342-040; 7342-070; 7342-510

The recirculation filter is located to the left of the operator's seat.

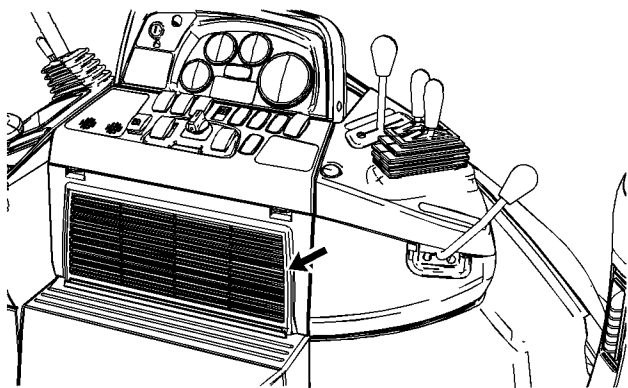

Illustration 224

g01251890

1. Remove the cover that is over the recirculation filter. Remove the filter element.
2. The filter element can be cleaned by using compressed air. Use a maximum air pressure of 205 kPa (30 psi). Direct the air from the clean side to the dirty side.
3. Look through the filter toward a bright light. Inspect the element for damage. Inspect the gaskets for damage. Replace damaged filters.
4. Install the filter element.

Note: Clean the filters more often in dusty conditions.

i01404606

Cab Interior - Clean

SMCS Code: 7301-070

1. Use high pressure air in order to clean the entire cab and the main electrical box.
2. Wash off any remaining dirt and debris. Use caution and minimize the water around electrical connections and the cab roof.
3. Scrub the floormat, the instrument panel, the windows, and the mirrors. Wipe the cab dry.

Cooling System Coolant (ELC) - Change

SMCS Code: 1353; 1395

WARNING

Pressurized system: Hot coolant can cause serious burn. To open cap, stop engine, wait until radiator is cool. Then loosen cap slowly to relieve the pressure.

NOTICE

Mixing ELC with other products will reduce the effectiveness of the coolant.

This could result in damage to cooling system components.

If Caterpillar products are not available and commercial products must be used, make sure they have passed the Caterpillar EC-1 specification for pre-mixed or concentrate coolants and Caterpillar Extender.

Note: This machine is shipped with Extended Life Coolant. Extended Life Coolant is recommended for use.

For information about the addition of Extender to your cooling system, see the Operation and Maintenance Manual, "Cooling System Coolant Extender (ELC) - Add" or consult your Caterpillar dealer.

Flushing the Extended Life Coolant From the Cooling System

Some engines utilize Extended Life Coolant. See the Operation and Maintenance Manual, "Maintenance Interval Schedule" in order to determine the service interval. If a Extended Life Coolant was previously used, flush the cooling system with clean water. No other cleaning agents are required.

Flushing a Standard Coolant From the Cooling System

If you change the coolant of a machine to Extended Life Coolant from another type of coolant, use a Caterpillar cleaning agent to flush the cooling system. After you drain the cooling system, thoroughly flush the cooling system with clean water. **All of the cleaning agent must be removed from the cooling system.**

Changing the Coolant

WARNING

Pressurized system: Hot coolant can cause serious burn. To open cap, stop engine, wait until radiator is cool. Then loosen cap slowly to relieve the pressure.

NOTICE

Do not change the coolant until you read and understand the material in the Cooling System Specifications section.

Drain the coolant whenever the coolant is dirty or whenever foaming is observed.

1. Install the lift cylinder brace. Refer to Operation and Maintenance Manual, "Lift Cylinder Brace - Connect and Disconnect" for more information.
2. Open the engine access door on the top of the machine.

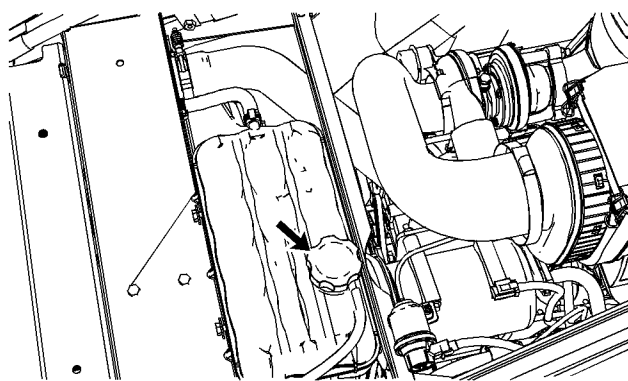

Illustration 225

g01179292

3. Slowly loosen the radiator cap in order to relieve system pressure. Remove the radiator cap slowly.
4. Remove the access panel on the right side of the engine compartment.

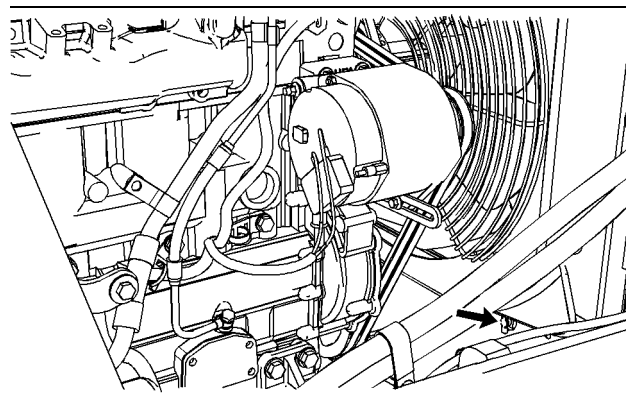

Illustration 226

g01179428

5. Open the drain valve. Face the end of the hose into a suitable container.
6. Close the drain valve. Fill the system with a solution which consists of clean water and of cooling system cleaner. The concentration of the cooling system cleaner in the solution should be between 6 percent and 10 percent.
7. Start the engine. Run the engine for 90 minutes. Stop the engine. Drain the cleaning solution into a suitable container.
8. While the engine is stopped, flush the system with water. Flush the system until the draining water is transparent.
9. Close the drain valve.
10. Add the coolant solution. See the following topics:
 - Special Publication, SEBU6250, "Caterpillar Machine Fluids Recommendations", "Cooling System Specifications"
 - Operation and Maintenance Manual, "Capacities (Refill)"

Note: If you are using Caterpillar antifreeze, do not add the supplemental coolant additive at this time and/or change the element at this time.

11. Start the engine. Run the engine without the radiator cap until the thermostat opens and the coolant level stabilizes.
12. Maintain the coolant level within 13 mm (0.5 inch) of the bottom of the filler pipe.
13. Install the radiator cap. Lower the tab on the radiator cap. Replace the radiator cap if the gasket is damaged.
14. Stop the engine.

15. Replace the access panel. Close the access door.

i03114912

Cooling System Coolant Extender (ELC) - Add

SMCS Code: 1352; 1353; 1395

WARNING

Pressurized system: Hot coolant can cause serious burn. To open cap, stop engine, wait until radiator is cool. Then loosen the cap slowly to relieve the pressure.

When a Caterpillar Extended Life Coolant is used, an extender must be added to the cooling system. See the Operation and Maintenance Manual, "Maintenance Interval Schedule" for the proper service interval. The amount of extender is determined by the cooling system capacity.

Table 74

RECOMMENDED AMOUNT OF EXTENDER BY COOLING SYSTEM CAPACITY	
Cooling System Capacity	Recommended Amount of Extender
22 to 30 L (6 to 8 US gal)	0.57 L (.60 qt)
30 to 38 L (8 to 10 US gal)	0.71 L (.75 qt)
38 to 49 L (10 to 13 US gal)	0.95 L (.95 qt)
49 to 64 L (13 to 17 US gal)	1.18 L (1.25 qt)

For additional information on the addition of extender, see Special Publication, SEBU6250, "Cat Extended Life Coolant (ELC) Cooling System Maintenance" or consult your Caterpillar dealer.

i02360553

Cooling System Coolant Level - Check

SMCS Code: 1350-535-FLV

WARNING

Pressurized system: Hot coolant can cause serious burn. To open cap, stop engine, wait until radiator is cool. Then loosen cap slowly to relieve the pressure.

Open the engine access door on the top of the hood.

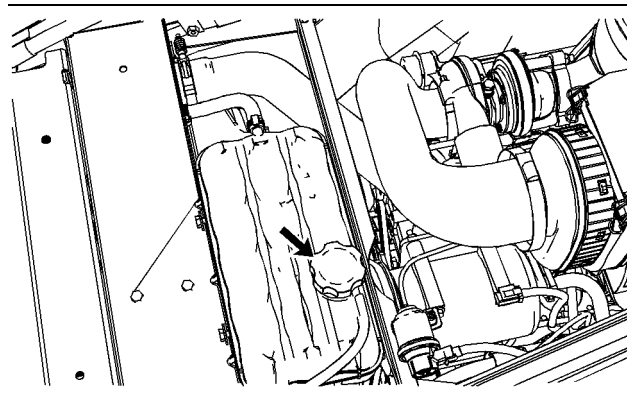

Illustration 227

g01179292

1. The radiator cap is located on the top of the radiator on the left side of the machine. Slowly loosen the cap in order to relieve system pressure. Remove the radiator cap slowly.
2. Maintain the coolant level within 13 mm (0.5 inch) of the bottom of the filler tube. If you need to add coolant daily, check the cooling system for leaks.
3. Inspect the radiator cap seal. Replace the radiator cap seal if the radiator cap seal is damaged.
4. Install the radiator cap. Lower the tab on the radiator cap. Close the access panel.

i02436473

Cooling System Coolant Sample (Level 1) - Obtain

SMCS Code: 1350-008; 1395-008; 7542

NOTICE

Care must be taken to ensure that fluids are contained during performance of inspection, maintenance, testing, adjusting and repair of the product. Be prepared to collect the fluid with suitable containers before opening any compartment or disassembling any component containing fluids.

Refer to Special Publication, NENG2500, "Caterpillar Dealer Service Tool Catalog" for tools and supplies suitable to collect and contain fluids on Caterpillar products.

Dispose of all fluids according to local regulations and mandates.

Note: Level 1 results may indicate a need for Level 2 Analysis.

i02436476

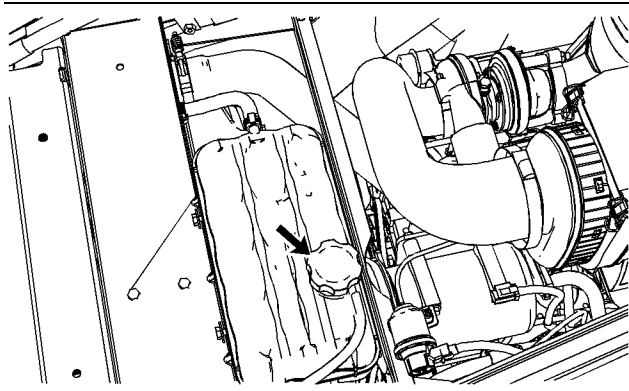

Illustration 228

g01179292

Obtain the sample of the coolant as close as possible to the recommended sampling interval. In order to receive the full effect of S·O·S analysis, you must establish a consistent trend of data. In order to establish a pertinent history of data, perform consistent samplings that are evenly spaced. Supplies for collecting samples can be obtained from your Caterpillar dealer.

Use the following guidelines for proper sampling of the coolant:

- Complete the information on the label for the sampling bottle before you begin to take the samples.
- Keep the unused sampling bottles stored in plastic bags.
- Obtain coolant samples directly from the coolant sample port. You should not obtain the samples from any other location.
- Keep the lids on empty sampling bottles until you are ready to collect the sample.
- Place the sample in the mailing tube immediately after obtaining the sample in order to avoid contamination.
- Never collect samples from expansion bottles.
- Never collect samples from the drain for a system.

Submit the sample for Level 1 analysis.

For additional information about coolant analysis, see Special Publication, SEBU6250, "Caterpillar Machine Fluids Recommendations" or consult your Caterpillar dealer.

Cooling System Coolant Sample (Level 2) - Obtain

SMCS Code: 1350-008; 1395-008; 7542

NOTICE

Care must be taken to ensure that fluids are contained during performance of inspection, maintenance, testing, adjusting and repair of the product. Be prepared to collect the fluid with suitable containers before opening any compartment or disassembling any component containing fluids.

Refer to Special Publication, NENG2500, "Caterpillar Dealer Service Tool Catalog" for tools and supplies suitable to collect and contain fluids on Caterpillar products.

Dispose of all fluids according to local regulations and mandates.

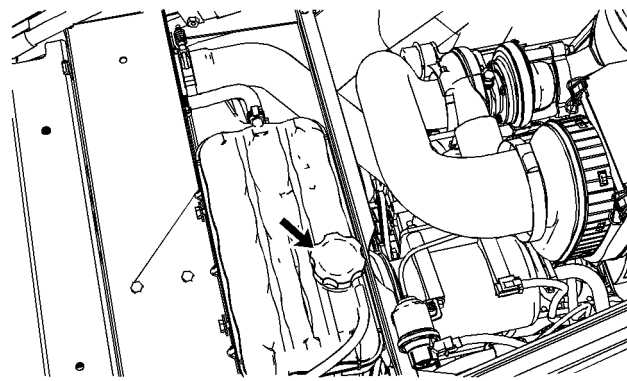

Illustration 229

g01179292

Obtain the sample of the coolant as close as possible to the recommended sampling interval. Supplies for collecting samples can be obtained from your Caterpillar dealer.

Refer to Operation and Maintenance Manual, "Cooling System Coolant Sample (Level 1) - Obtain" for the guidelines for proper sampling of the coolant.

Submit the sample for Level 2 analysis.

Reference: For additional information about coolant analysis, refer to Special Publication, SEBU6250, "Caterpillar Machine Fluids Recommendations" or consult your Caterpillar dealer.

i02510469

Cooling System Water Temperature Regulator - Clean/Replace

SMCS Code: 1355; 1393

Replace the thermostat on a regular basis in order to reduce the chance of unscheduled downtime and of problems with the cooling system. Failure to replace the engine's thermostat on a regularly scheduled basis could cause severe engine damage.

The thermostat should be replaced after the cooling system has been cleaned. Replace the thermostat while the cooling system is completely drained or while the cooling system coolant is drained to a level that is below the thermostat housing.

Note: If you are only replacing the thermostat, drain the cooling system coolant to a level that is below the thermostat housing.

Caterpillar engines incorporate a shunt design cooling system. It is mandatory to always operate the engine with a thermostat.

1. Install the lift cylinder brace. Refer to Operation and Maintenance Manual, "Lift Cylinder Brace - Connect and Disconnect" for more information.
2. Remove the engine access panel on the right side of the machine.

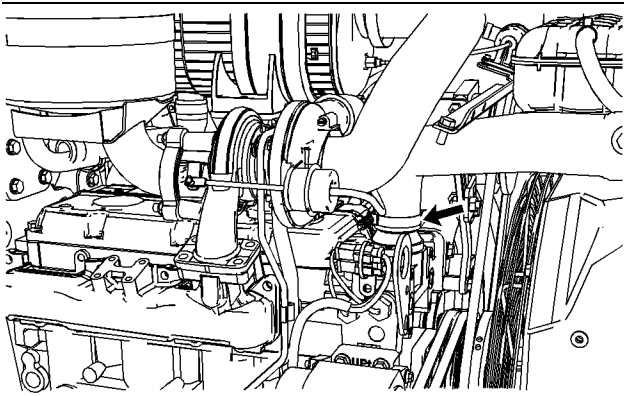

Illustration 230

g01179553

3. Loosen the hose clamp and remove the hose from the thermostat housing assembly.
4. Remove the bolts from the thermostat housing assembly. Remove the thermostat housing assembly.
5. Remove the gasket, the thermostat, and the seal from the thermostat housing assembly.

6. Install a new seal in the thermostat housing assembly. Install a new thermostat and a new gasket. Install the thermostat housing assembly on the engine cylinder head.

The thermostats can be reused under the following conditions.

- The thermostat is tested and the thermostat meets test specifications.
- The thermostat is not damaged.
- The thermostat does not have excessive buildup of deposits.

7. Install the hose. Tighten the hose clamp.
8. Refill the cooling system. Refer to Special Publication, "Cooling System Specifications" and Operation and Maintenance Manual, "Capacities (Refill)".

i02567860

Differential Oil (Front) - Change

SMCS Code: 3258

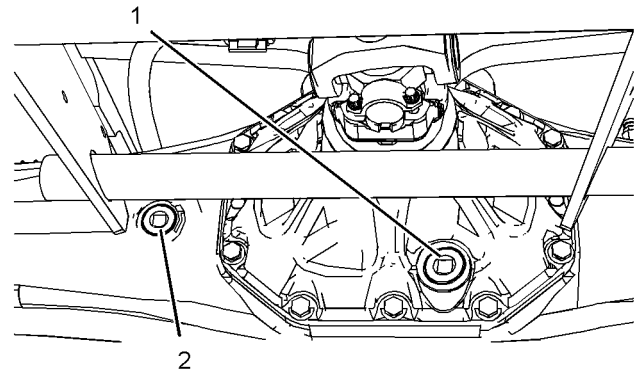

Illustration 231

g01286266

1. Remove oil drain plug (1) and drain the oil into a suitable container.
2. The drain plug is magnetic. Check the plug for metal.
3. Clean the drain plug and install the drain plug.
4. Remove oil level/fill plug (2).
5. Add oil until the oil is level with the threads for the filler plug. Refer to Operation and Maintenance Manual, "Lubricant Viscosities" and Operation and Maintenance Manual, "Capacities (Refill)" for oil.
6. Clean the filler plug and install the filler plug.

i02419881

Differential Oil (Rear) - Change

SMCS Code: 3258

The oil change interval should be decreased to 500 hours if more than 50% of the service hours is used for roading and loading.

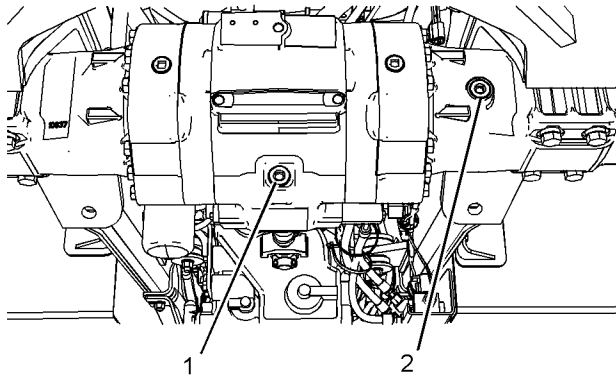

Illustration 232

g01209215

1. Remove oil drain plug (1) and drain the oil into a suitable container.
2. Clean the drain plug and install the drain plug.
3. Remove oil level/fill plug (2).
4. Add oil until the oil is level with the threads for the filler plug. Refer to Operation and Maintenance Manual, "Lubricant Viscosities" and Operation and Maintenance Manual, "Capacities (Refill)" for oil.
5. Clean the filler plug and install the filler plug.

i02363607

Differential Oil Level (Front) - Check

SMCS Code: 3258

The oil level/fill plug is located near the middle of the front axle.

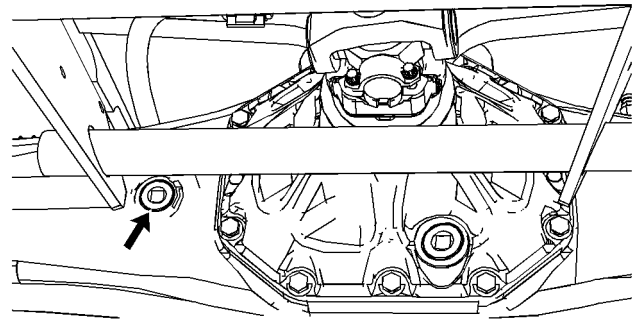

Illustration 233

g01180551

1. Remove the oil level/fill plug in order to check the oil.
2. The oil level should be at the bottom of the plug threads.
3. Clean the oil level/fill plug and install the oil level/fill plug.

i02419882

Differential Oil Level (Rear) - Check

SMCS Code: 3258

The oil level/fill plug is located near the middle of the rear axle.

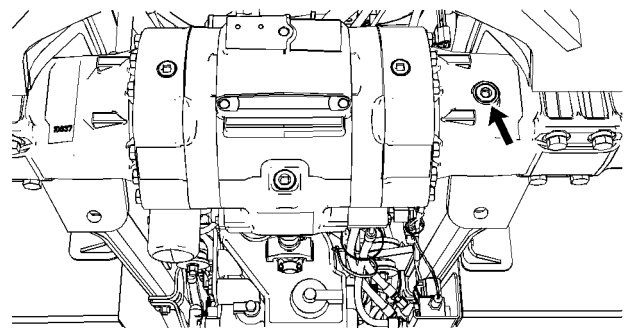

Illustration 234

g01209217

Filler plug on standard rear differential

1. Remove the oil plug in order to check the oil.
2. The oil level should be at the bottom of the plug threads.
3. Clean the oil plug and install the oil plug.

i02363692

Differential Oil Sample (Front) - Obtain

SMCS Code: 3258-008; 7542-008

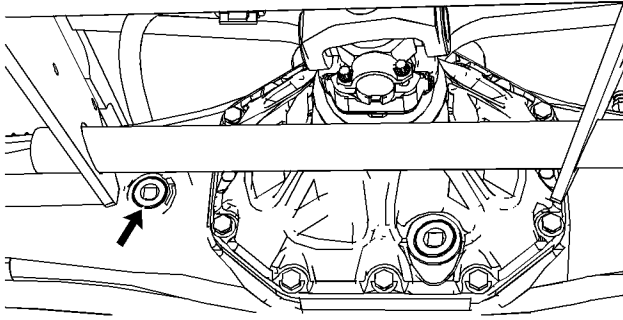

Illustration 235

g01180551

Obtain the oil sample according to the Operation and Maintenance Manual, "Maintenance Interval Schedule".

Refer to the Operation and Maintenance Manual, "General Hazard Information" for information that pertains to containing fluid spillage.

Refer to the Special Publication, SEBU6250, "S-O-S Oil Analysis" for more information.

i02436482

Differential Oil Sample (Rear) - Obtain

SMCS Code: 3258-008; 7542-008

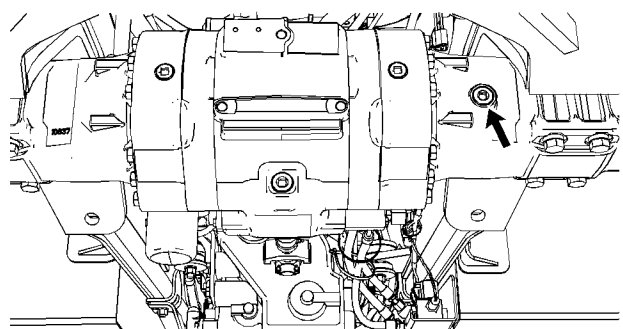

Illustration 236

g01209217

Obtain the oil sample according to the Operation and Maintenance Manual, "Maintenance Interval Schedule".

Refer to the Operation and Maintenance Manual, "General Hazard Information" for information that pertains to containing fluid spillage.

Refer to the Special Publication, SEBU6250, "S-O-S Oil Analysis" for more information.

i02363714

Drive Shaft Spline - Lubricate

SMCS Code: 3253

Access the grease fittings for the drive shaft spline from the bottom of the machine.

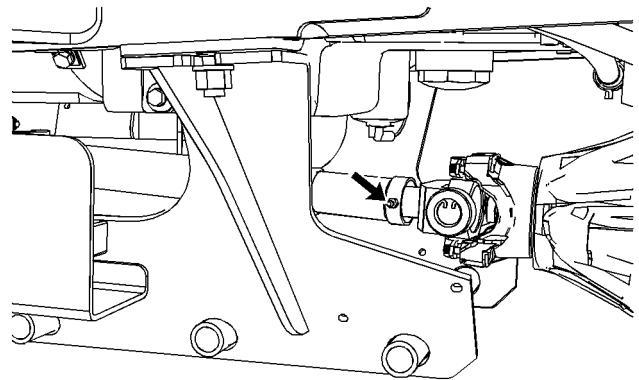

Illustration 237

g01180607

Apply lubricant to the grease fitting for the drive shaft spline of the front drive shaft.

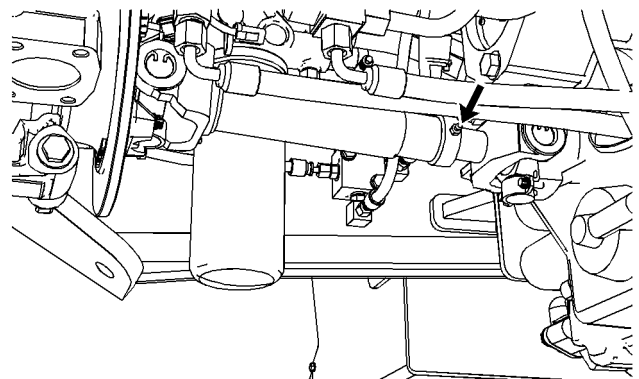

Illustration 238

g01180608

Apply lubricant to the grease fitting for the drive shaft spline of the rear drive shaft.

i02510477

Engine Air Filter Primary Element - Clean/Replace

SMCS Code: 1051; 1054

NOTICE

Service the air cleaner only with the engine stopped. Engine damage could result.

Service the air cleaner filter element when the yellow piston on the engine air filter service indicator enters the red zone or the indicator reads 63.5 cm (25 inch) of water. Refer to Operation and Maintenance Manual, “Engine Air Filter Service Indicator - Inspect”.

1. Open the engine access door on the top of the machine.

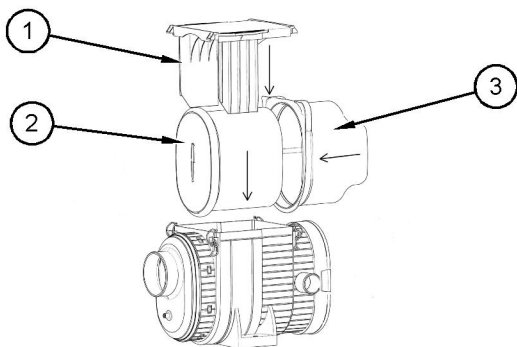

Illustration 239

g01031497

2. Remove cover (1) for the air filter housing .
3. Remove primary filter element (2) from the air filter housing.
4. Slide the primary filter element out of the filter base (3).
5. Clean the inside of the air filter housing.
6. Slide a clean primary air filter element into the filter base. Install the clean filter into the air filter housing. Install the cover for the air filter housing.

Note: Refer to “Cleaning Primary Air Filter Elements”.

7. Reset the engine air filter service indicator.
8. Close the access door.

If the yellow piston in the indicator moves into the red zone after starting the engine or the exhaust smoke is still black after installation of a clean primary filter element, install a new primary filter element. If the piston remains in the red zone replace the secondary element.

Cleaning Primary Air Filter Elements

NOTICE

Caterpillar recommends certified air filter cleaning services available at participating Caterpillar dealers. The Caterpillar cleaning process uses proven procedures to assure consistent quality and sufficient filter life.

Observe the following guidelines if you attempt to clean the filter element:

Do not tap or strike the filter element in order to remove dust.

Do not wash the filter element.

Use low pressure compressed air in order to remove the dust from the filter element. Air pressure must not exceed 207 kPa (30 psi). Direct the air flow up the pleats and down the pleats from the inside of the filter element. Take extreme care in order to avoid damage to the pleats.

Do not use air filters with damaged pleats, gaskets, or seals. Dirt entering the engine will cause damage to engine components.

The primary air filter element can be used up to six times if the element is properly cleaned and inspected. When the primary air filter element is cleaned, check for rips or tears in the filter material. Every two years replace the primary air filter element at least one time. This replacement should be performed regardless of the number of cleanings.

NOTICE

Do not clean the air filter elements by bumping or tapping. This could damage the seals. Do not use elements with damaged pleats, gaskets, or seals. Damaged elements will allow dirt to pass through. Engine damage could result.

Visually inspect the primary air filter elements before cleaning. Inspect the air filter elements for damage to the seal, the gaskets, and the outer cover. Discard any damaged air filter elements.

There are two common methods that are used to clean primary air filter elements:

- Pressurized air

- Vacuum cleaning

Pressurized Air

Pressurized air can be used to clean primary air filter elements that have not been cleaned more than two times. Pressurized air will not remove deposits of carbon and oil. Use filtered, dry air with a maximum pressure of 207 kPa (30 psi).

Note: When the primary air filter elements are cleaned, always begin with the clean side (inside) in order to force dirt particles toward the dirty side (outside).

Vacuum Cleaning

Vacuum cleaning is another method for cleaning primary air filter elements which require daily cleaning because of a dry, dusty environment. Cleaning with pressurized air is recommended prior to vacuum cleaning. Vacuum cleaning will not remove deposits of carbon and oil.

Inspecting the Primary Air Filter Elements

Inspect the clean, dry primary air filter element. Inspect the primary air filter element for tears and/or holes. If it is necessary in order to confirm the result, compare the primary air filter element to a new primary air filter element that has the same part number.

Do not use a primary air filter element that has any tears and/or holes in the filter material. Do not use a primary air filter element with damaged pleats, gaskets or seals. Discard damaged primary air filter elements.

Storing Primary Air Filter Elements

If a primary air filter element that passes inspection will not be used, the primary air filter element can be stored for future use.

Do not use paint, a waterproof cover, or plastic as a protective covering for storage. An air flow restriction may result. To protect against dirt and damage, wrap the primary air filter elements in Volatile Corrosion Inhibited (VCI) paper.

Place the primary air filter element into a box for storage. For identification, mark the outside of the box and mark the primary air filter element. Include the following information:

- Date of cleaning
- Number of cleanings

Store the box in a dry location.

i01991300

Engine Air Filter Secondary Element - Replace

SMCS Code: 1051; 1054

NOTICE

Always replace the secondary filter element. Never attempt to reuse it by cleaning.

The secondary filter element should be replaced at the time the primary element is serviced for the third time. The secondary filter element should be replaced everytime the primary element is replaced.

The secondary filter element should also be replaced if the yellow piston in the filter element indicator enters the red zone after installation of a clean primary element, or if the exhaust smoke is still black.

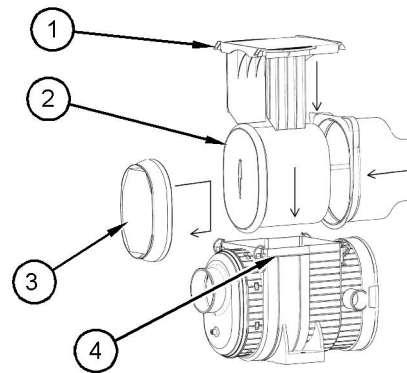

Illustration 240

g01031378

1. Remove the air cleaner housing cover (1).
2. Remove the primary filter element (2) from the air cleaner housing.
3. Clean the inside of the air cleaner housing (4) with a wet rag before the secondary filter element (3) is removed.
4. Inspect the gasket between the air inlet pipe and the air cleaner housing. Replace the gasket if the gasket is damaged.
5. Install a new secondary element.
6. Install the primary element and the air cleaner housing cover. Fasten the clips in order to secure the air cleaner housing cover.
7. Reset the filter element indicator.

8. Close the engine access door.

i02363812

Engine Air Filter Service Indicator - Inspect

SMCS Code: 1051; 1054; 7452

NOTICE

Service the air cleaner only with the engine stopped. Engine damage could result.

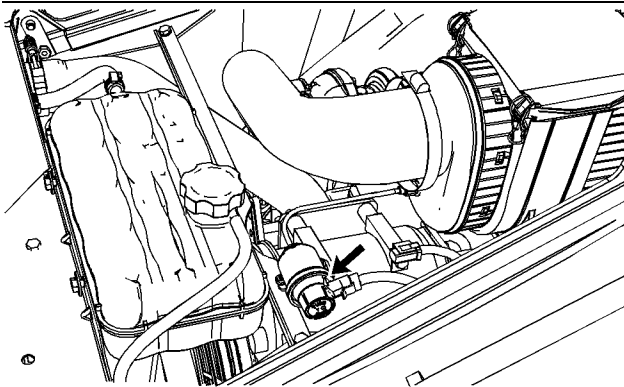

Illustration 241

g01180675

The filter service indicator is located under the engine access door in front of the housing for the air filter.

Start the engine. Run the engine at high idle. If the yellow piston in the filter service indicator enters the red zone, service the air cleaner. Stop the engine.

i03480012

Engine Air Precleaner - Clean

SMCS Code: 1055-070

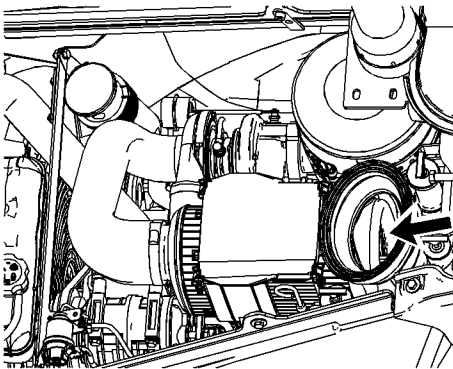

Illustration 242

g01818670

1. Inspect the engine air precleaner for dirt and for trash.

2. Remove the precleaner in order to clean the precleaner.

3. Use pressurized air to clean the tubes. Put the tubes on a flat surface. Direct the pressurized air into the tubes from the top. This loosens up the dirt.

a. Loosen hard deposits of dust on the precleaner body by soaking in an appropriate cleaning agent. Then, wash the precleaner body with a spray of water.

b. Blow dry the precleaner body completely.

4. Install the precleaner.

5. Install T-bolt (1). Hand tighten the T-bolt only.

6. Close the left engine access door.

NOTICE

Service the air cleaner only with the engine stopped. Engine damage could result.

i01404793

Engine Compartment - Clean

SMCS Code: 1000-070

NOTICE

Before spraying the engine compartment with high pressure water turn off the engine and allow the engine to cool. Do not spray water directly on a hot fuel injection pump or damage may occur.

Use a commercially available engine degreaser in order to clean the engine compartment. Use caution and minimize the water around bearings and electrical connections.

i02409844

Engine Crankcase Breather - Replace

SMCS Code: 1317-510

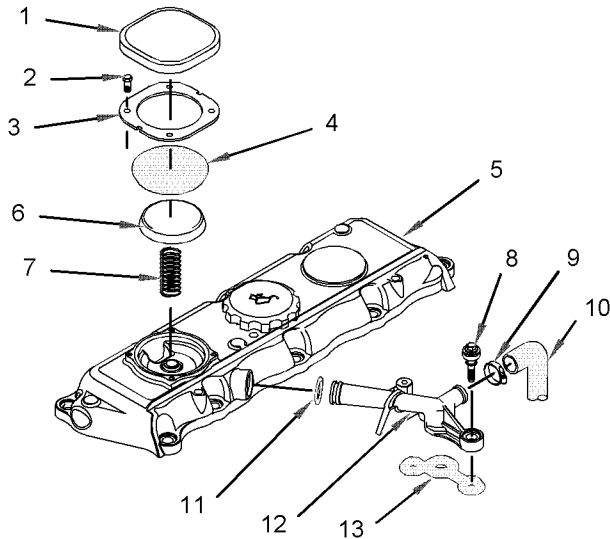

Illustration 243

g01149576

1. Loosen the clamp (9) and remove the hose (10) from the connector (12).
2. Remove the setscrews (8) and remove the connector (12) from the cylinder head. Remove the gasket (13). Remove the O-ring seal (11) from the connector. Discard the gasket (13) and the O-ring seal (11).
3. Remove the cover (1) from the valve mechanism cover (5).

WARNING

Personal injury can result from parts and/or covers under spring pressure.

Spring force will be released when covers are removed.

Be prepared to hold spring loaded covers as the bolts are loosened.

4. Remove the screws (2). Remove the plate (3).
5. Remove the diaphragm (4) and the cap (6). Remove the spring (7). Discard diaphragm (4).

WARNING

Improper assembly of parts that are spring loaded can cause bodily injury.

To prevent possible injury, follow the established assembly procedure and wear protective equipment.

6. Install the spring (7), the cap (6), and a new diaphragm (4).
7. Install the plate (3). Install the screws (2).
8. Install the cover (1) on the valve mechanism cover.
9. Install a new O-ring seal (11) on the connector (12). Install a new gasket (13) on the connector (12). Position the connector in the valve mechanism cover.
10. Install the setscrews (8). Tighten the setscrews to a torque of 9 N·m (80 lb in).
11. Install the hose (10) on the connector (12). Tighten the clamp (9) to a torque of 5 N·m (44 lb in).

i02363877

Engine Oil Level - Check

SMCS Code: 1302; 1318; 1326

NOTICE

Do not overfill the crankcase. Engine damage can result.

1. Open the engine access door on the top of the machine.

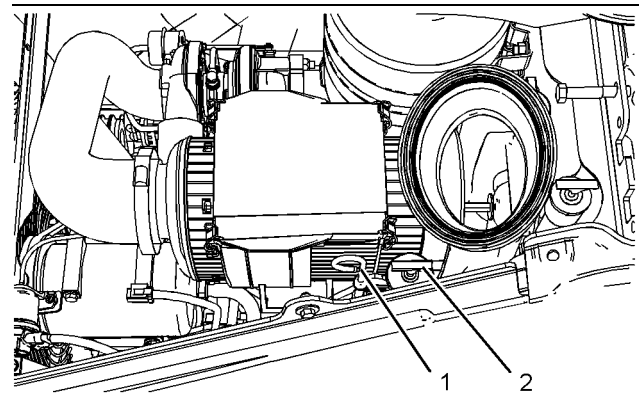

Illustration 244

g01180730

2. While the engine is stopped, maintain the oil level between the "ADD" mark and the "FULL" mark on the engine oil dipstick (1).

3. If necessary, remove the oil filler cap (2) and add oil.
4. Clean the oil filler cap and install the oil filler cap.
5. Close the engine access door.

i03577889

Engine Oil Sample - Obtain

SMCS Code: 1348-008; 7542-008

Use the sampling valve in order to obtain a sample of the engine oil. The sampling valve is located on the side of the engine next to the oil filter base. The engine must be running in order to take a sample of the engine oil.

Refer to Special Publication, SEBU6250, "Caterpillar Machine Fluids Recommendations", "S-O-S Oil Analysis" for information that pertains to obtaining an oil sample. Refer to Special Publication, PEHP6001, "How To Take A Good Oil Sample" for more information about obtaining an oil sample.

i02363963

Engine Oil and Filter - Change

SMCS Code: 1302; 1318; 1326

Note: If the sulfur content in the fuel is greater than 1.5% by weight, use an oil with a TBN of 30. With the high sulfur fuel, change the oil and the filter element after every 250 hours or after every month. If the API category is CF-4 or less, change the oil and change the filter element after every 250 hours or after every month. Otherwise, change the oil and the filter element after every 500 hours or after every three months.

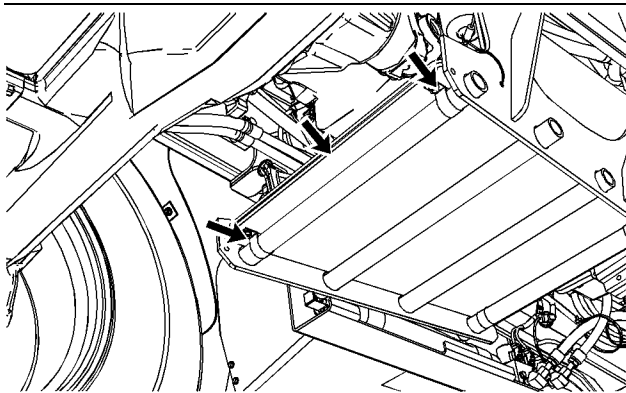

Illustration 245

g01217542

1. If equipped, remove the sound plate from the bottom of the transmission guard. Remove the four clips that secure the sound plate to the transmission guard.

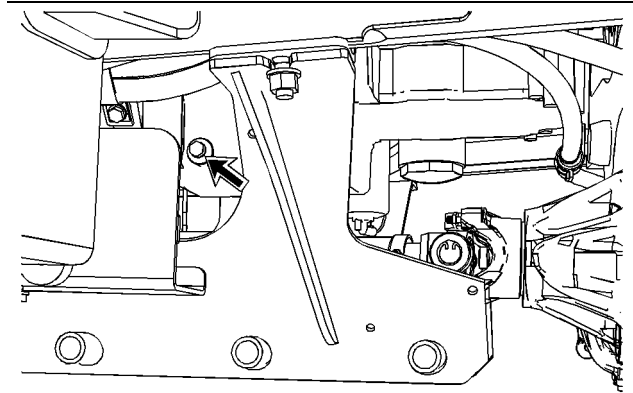

Illustration 246

g01180759

2. Remove the crankcase drain plug and drain the oil into a suitable container. Clean the crankcase drain plug and replace the crankcase drain plug.

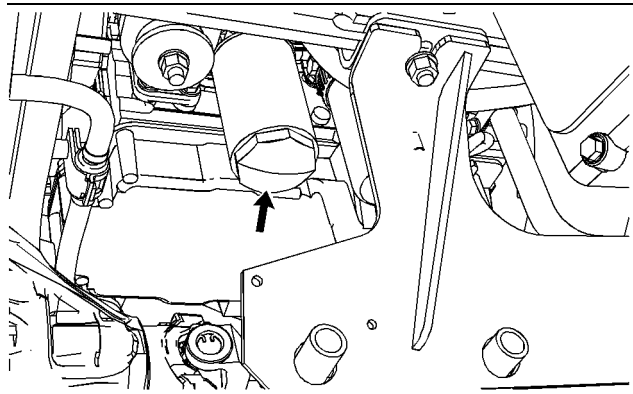

Illustration 247

g01180774

3. Remove the filter element with a strap type wrench.
4. Clean the filter mounting base with a clean cloth. Make sure that the old filter gasket has been removed.
5. Apply a thin film of clean engine oil to the sealing surface of the new filter element.
6. Install the new oil filter by hand.

Instructions for the installation of the filter are printed on the side of each Caterpillar spin-on filter. For non-Caterpillar filters, refer to the installation instructions that are provided by the supplier of the filter.

7. Open the engine access door on the top of the machine.

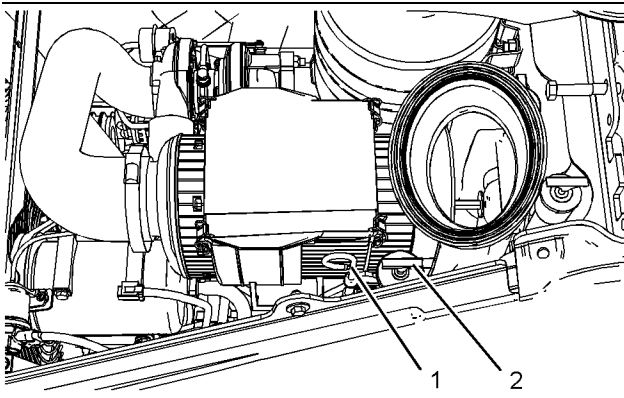

Illustration 248

g01180730

8. Remove the oil filler cap (2). Fill the crankcase with new oil. Refer to Operation and Maintenance Manual, "Lubricant Viscosities" and Operation and Maintenance Manual, "Capacities (Refill)". Clean the oil filler cap and install the oil filler cap.
9. Start the engine and allow the oil to warm. Check for leaks.
10. Stop the engine and allow the oil to drain back into the oil pan. Maintain the oil level in the crosshatched region of the engine oil dipstick (1). Add oil, if necessary.
11. Replace the engine access panel and close the engine access door.

i01897328

Engine Valve Lash - Check

SMCS Code: 1102-082; 1102-535; 1102; 1209-082; 1209

Note: A qualified service person should perform the valve lash check and/or the valve lash adjustment. Special tools and training are required.

Refer to your machine's Service Manual for complete instructions.

i03066310

Extendable Stick Pads - Inspect/Adjust (If Equipped)

SMCS Code: 6533-025; 6533-040

Note: The wear pads on the extendable stick are impregnated with a lubricant. The wear pads do not require the application of lubricant. Do not apply lubricant to the pads.

Upper Wear Pad

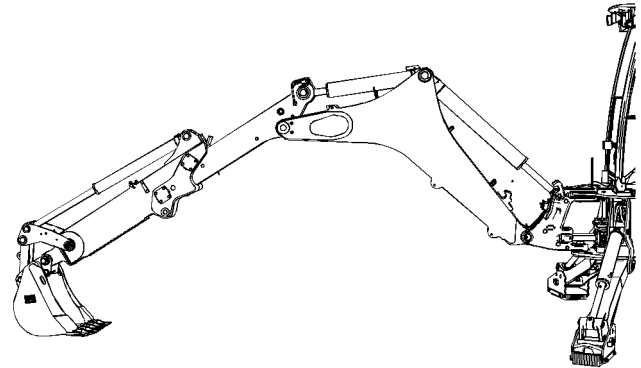

Illustration 249

g01359011

1. Position the machine as shown in figure 249.
2. Raise the rear of the backhoe so that tires are 25.4 mm (1 inch) off of the ground.
3. Fully extend the stick. Then, retract the stick 76.2 mm to 101.6 mm (3 inch to 4 inch).
4. Pull stick in and position the rear bucket so that the bottom of the bucket and the bucket teeth are flat on the ground.
5. Fully extend the extendable stick. Lift the stabilizers off the ground.

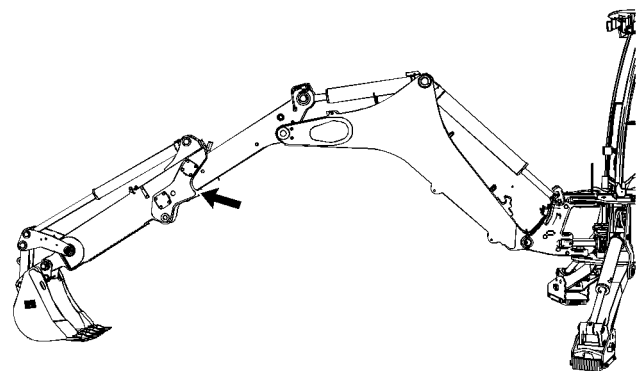

Illustration 250

g01359257

6. Use a feeler gauge in order to measure the gap between wedge (1) and the bottom surface of the inner stick. The gap should be between 0.5 mm (0.0197 inch) and 1.0 mm (0.0394 inch).
7. Check for clearance on the upper wear pad. If the gap between the upper wear pad and the bottom surface of the inner stick is less than 0.5 mm (0.02 inch) proceed to Step 8, or more than 1 mm (0.04 inch) proceed to Step 9.

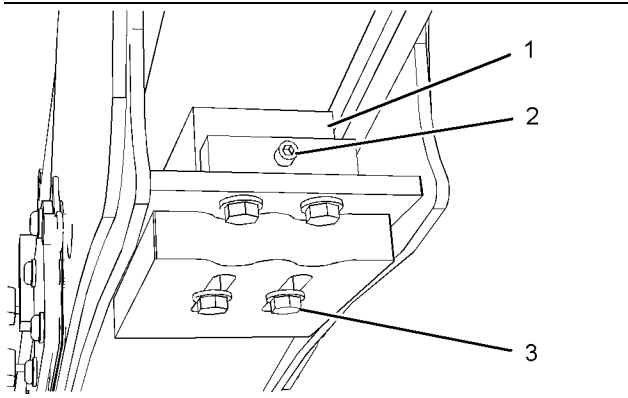

Illustration 251

g01359172

8. If the gap is less than 0.5 mm (0.0197 inch), perform steps 8.a through 8.i.
 - a. Retract the extendable stick halfway.
 - b. Loosen two bolts (3) that secure the upper wear pad (1) in place.
 - Note:** Do not loosen the two bolts that are under the setscrew.
 - c. Loosen set screw (2) by two turns.
 - d. Fully extend the stick. The upper wear pad should slide back to the stop.
 - e. Return the machine to the position that is shown in figure 251.
 - f. Turn the set screw counterclockwise in order to increase the gap.
 - g. After you set the clearance, tighten bolts (3) in order to secure the upper wear pad.
 - h. Measure the gap that is between the wedge and the bottom surface of the inner stick. If necessary, perform steps 8.a through 8.g.
 - i. When the gap is correct, apply 154-9731 Thread Lock Compound to both bolts (3).
 - j. Torque bolts (3) to $100 \pm 20 \text{ N}\cdot\text{m}$ ($74 \pm 15 \text{ lb ft}$).
 - k. Proceed to Step 10.
9. If the gap is more than 1.0 mm (0.0394 inch), perform steps 9.a through 9.e.
 - a. Loosen two bolts (3) that secure the upper wear pad (1) in place.

Note: Do not loosen the two bolts that are under the setscrew.

- b. Turn set screw (2) clockwise in order to decrease the gap.
 - c. Tighten two bolts (3) in order to secure the upper wear pad.
 - d. Measure the gap that is between the wedge and the bottom surface of the inner stick. If necessary, perform steps 9.a through 9.c.
 - e. When the gap is correct, apply 154-9731 Thread Lock Compound.
 - f. Torque bolts (3) to $100 \pm 20 \text{ N}\cdot\text{m}$ ($74 \pm 15 \text{ lb ft}$).
 - g. Proceed to Step 10.
10. Check extension of the stick after adjusting the upper wear pad.
 - a. Set the stick horizontally to the ground.
 - b. Extend the stick and retract the stick in order to check for any vibrations.
 - c. If no vibration is evident, continue to "Inspect the Gap of the Lower Wear Pads".
 - d. If the vibration is evident, adjust the upper wear pad to the maximum gap of 1 mm (0.04 inch). If the vibration continues contact the Dealer Service Network (DSN).

Note: A small amount of vertical movement of the outer slider is acceptable with a gap of 1 mm (0.04 inch).

Inspect the Gap of the Lower Wear Pads

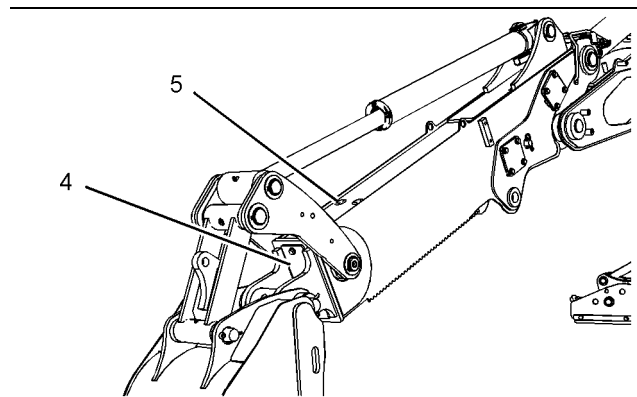

Illustration 252

g01359314

1. Remove access plate (4) and remove the two caps for the access holes (5).

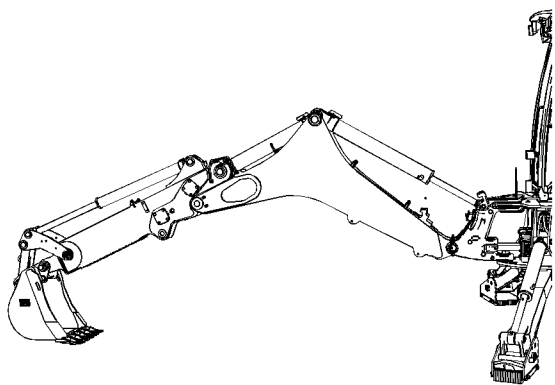

Illustration 253

g01359277

2. Position the machine. Refer to Illustration 253
3. Fully retract the extendable stick in order to allow access through the nose of the stick. Slightly lift the rear of the machine.
4. At access holes (5), measure the gap between the top of the flat wear pad that is bolted to the inner stick and the inside surface of the outer stick.
5. Check for clearance on the lower wear pad. If the gap between the lower wear pad and the bottom surface of the outer stick is less than 0.5 mm (0.02 inch) proceed to Step 6, or more than 1 mm (0.04 inch) proceed to Step 7.
6. If the gap is less than 0.5 mm (0.0197 inch), perform the following steps:
 - a. Loosen the two bolts (6) that secure the lower wear pad in place.

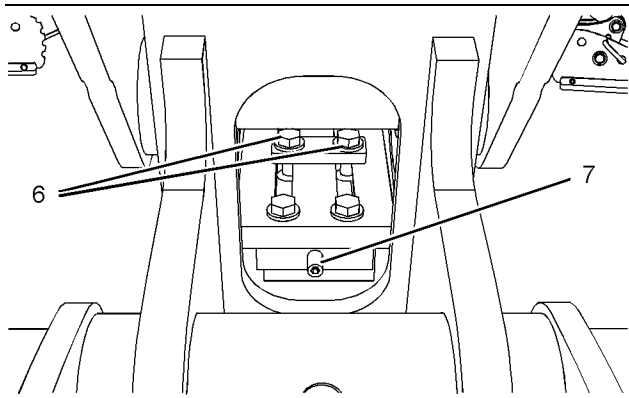

Illustration 254

g01359416

- a. Loosen the two bolts (6) that secure the lower wear pad in place.

Note: Do not loosen the two bolts that are under the setscrew.

- b. Turn set screw (7) counterclockwise by two turns.

- c. Slide the stick out 25 mm (1 inch) to 75 mm (3 inch).

Note: The lower wear pad should return against the set screw. This will create a gap between the lower wear pad and the outer extendable stick.

Note: Ensure that the wear pad is pulled back against the set screw. Tighten the bolts. Ensure that you can access the bolts after the stick has been extended by a few inches.

- d. Return the machine to the position that is shown in figure 253.
 - e. Measure the gap and make any needed adjustments.
 - f. If the gap is correct, apply 154-9731 Thread Lock Compound to both bolts (6).
 - g. Torque the bolts (6) to 100 ± 20 N·m (74 ± 15 lb ft).
7. If the gap is more than 1.0 mm (0.0394 inch), perform steps:
 - a. Loosen the two bolts (6) that secure the lower wear pad in place.

Note: Do not loosen the two bolts that are under the setscrew.

- b. Turn set screw (7) clockwise in order to decrease the gap.
- c. Measure the gap and make any needed adjustments.
- d. If the gap is correct, apply 154-9731 Thread Lock Compound to both bolts (6).
- e. Torque the bolts (6) to 100 ± 20 N·m (74 ± 15 lb ft).

Checking Extension of the Stick

1. Set the stick so the stick is horizontal to the ground.
2. Extend and retract the extendable stick in order to check for any vibrations.
3. If no vibration is evident, proceed to "Adjustment of the Side Pad".
4. If the adjustment of the wedge has been performed and vibration is evident proceed to "Adjustment of the Side Pad".

Note: A small amount of vertical movement of the outer slider is acceptable with a gap of 1.0 mm (0.0394 inch).

Adjustment of the Side Pad

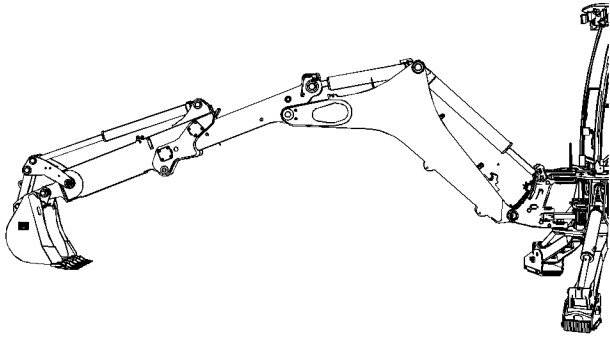

Illustration 255

g01359481

1. Position the machine. Refer to Illustration 255.

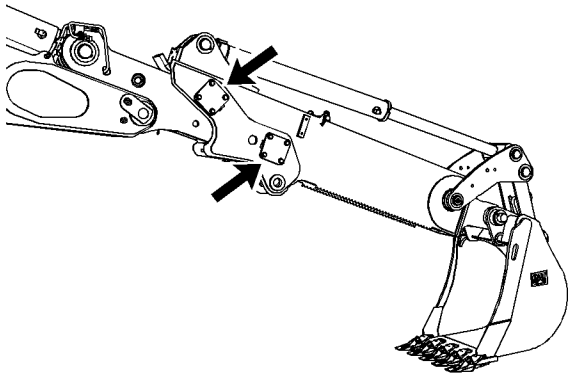

Illustration 256

g01283762

2. Raise the rear of the backhoe and make sure that the boom nose is level with the ground. Fully extend the stick and place the curled bucket slightly off the ground.
3. Check for free play between the side wear pads and the inner section of the stick.
4. Check each side wear pad with the outer slider in the following positions.
 - Extended 50.8 mm (2 inch) to 76.2 mm (3 inch)
 - Half extended
 - Fully extended

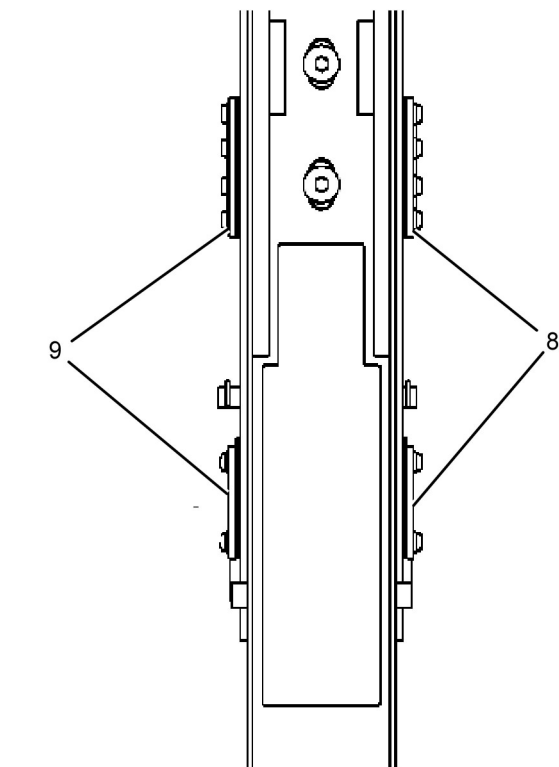

Illustration 257

g01413212

- (8) 0.25 mm (0.0098 inch)
- (9) No gap

5. Use a 0.25 mm (0.0098 inch) feeler gauge to check each side wear pad. One side should have no gap between the inner slider and the face of the pad (9). The other side should have a 0.25 mm (0.0098 inch) or less gap (8). See Illustration 257.
6. Ensure that a 0.25 mm (0.0098 inch) gap is present at the widest part of the three checked positions. This will be the position of the smallest gap between the inner slider and side wear pad. Setting the 0.25 mm (0.0098 inch) gap at a narrow point of the inner slider may allow vibrating as the wear pads travel over the wider points of the slider.
7. If adjustment is required, perform the following steps:

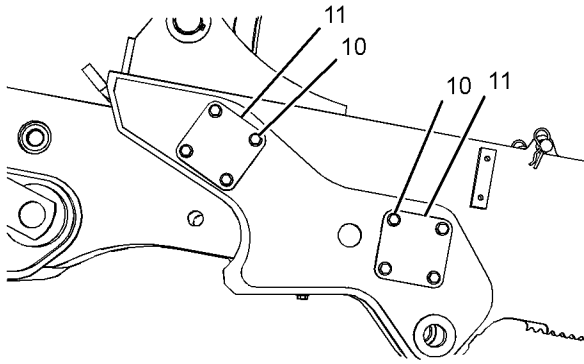

Illustration 258

g01413217

(10) 284-3615 Hex Socket Screws
(11) 233-5165 Plate

- a. Remove the four hex socket screws (10) and the plate (11).
- b. Apply an adequate number of shims in order to make the side lower wear pad flush with shims.

Note: The amount of shims should be equal on both sides within 0.5 mm (0.02 inch). The top side pad and bottom side pad do not need to have an equal number of shims.

- c. Reassemble the cover (11) and torque the hex socket screws (10) to 50 ± 10 N·m (37 ± 7 lb ft).
 - d. Repeat steps for the remaining three additional side pads.
 - e. Proceed to Step 8.
8. Check extension of the stick after adjusting the side wear pads.
- a. Set the stick horizontally to the ground.
 - b. Extend the stick and retract the stick in order to check for any vibrations.
 - c. If adjustment is too tight, then add a 0.5 mm (0.02 inch) shim to one of the side pads and recheck the adjustment.

Note: Choose a pad with the heaviest wear marks.

- d. If adjustment is still too tight, then add a 0.5 mm (0.02 inch) shim to the corresponding pad on the other side and recheck the adjustment.
- e. If adjustment continues to be too tight, then add a 0.5 mm (0.02 inch) shim to the remaining wear pads.

Note: Recheck for vibration before the addition of each shim. Do not exceed 0.5 mm (0.02 inch) of additional shimming at all four pads.

- f. If the stick continues to vibrate, contact the DSN.

i02369952

Final Drive Oil (Front) - Change

SMCS Code: 4050

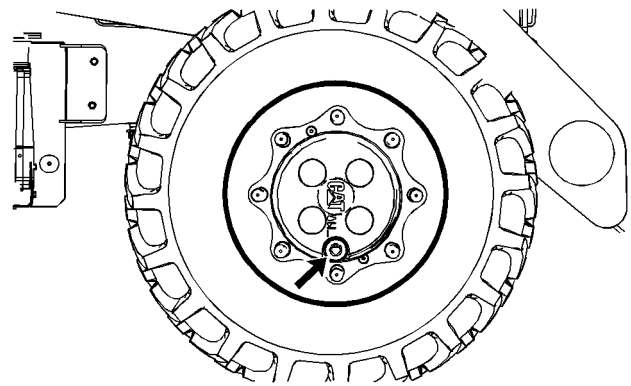

Illustration 259

g01182475

1. Position the oil fill/drain plug at the bottom. Remove the oil fill/drain plug and drain the oil into a suitable container.
2. The plug is magnetic. The plug will attract metal from the oil. Check the plug for an increased amount of metal on the plug. If any abnormal particles are found, consult your Caterpillar dealer.

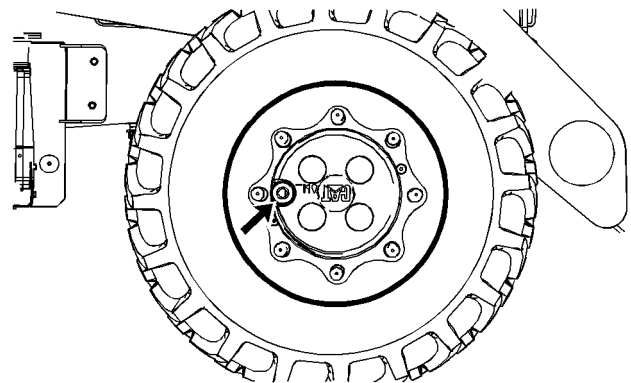

Illustration 260

g01182493

3. Position the plug hole at a horizontal position. Use the line on the final drive as a reference.

4. Add oil until the oil is level with the plug threads. Refer to Operation and Maintenance Manual, "Lubricant Specifications" and Operation and Maintenance Manual, "Capacities (Refill)" for the oil.
5. Clean the plug and install the plug.
6. Repeat the procedure for the other final drive.

i02404350

Final Drive Oil (Rear) - Change

SMCS Code: 4050

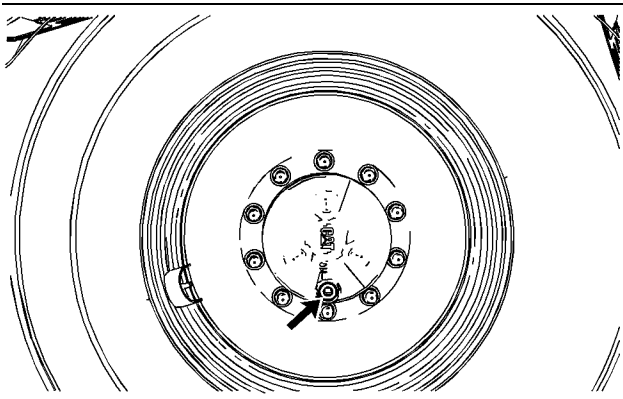

Illustration 261

g01200973

1. Position the oil fill/drain plug at the bottom. Remove the oil fill/drain plug and drain the oil into a suitable container.

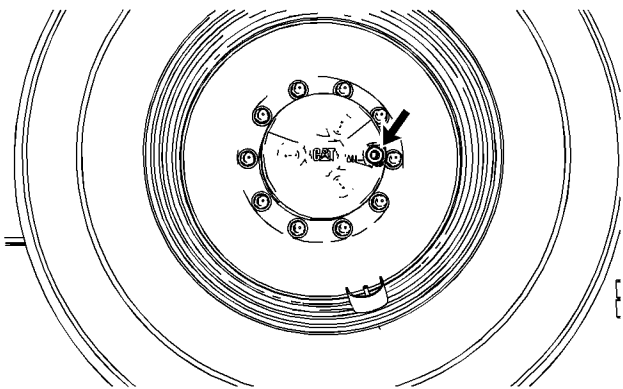

Illustration 262

g01200981

2. Position the plug hole at a horizontal position. Use the line on the final drive as a reference.
3. Add oil until the oil is level with the plug threads. Refer to Operation and Maintenance Manual, "Lubricant Specifications" and Operation and Maintenance Manual, "Capacities (Refill)" for the oil.
4. Clean the plug and install the plug.

5. Repeat the procedure for the other final drive.

i02370034

Final Drive Oil Level (Front) - Check

SMCS Code: 4050

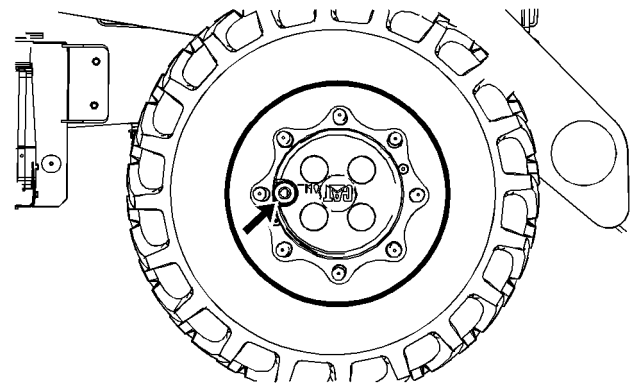

Illustration 263

g01182493

1. Position the oil fill/drain plug at a horizontal position in order to check the oil level.
2. Remove the oil fill/drain plug in order to check the oil level.
3. The oil should be level with the bottom of the plug threads.
4. The plug is magnetic. Check the plug for metal. Clean the plug and install the plug.
5. Repeat the procedure for the other final drive.

i02404426

Final Drive Oil Level (Rear) - Check

SMCS Code: 4050

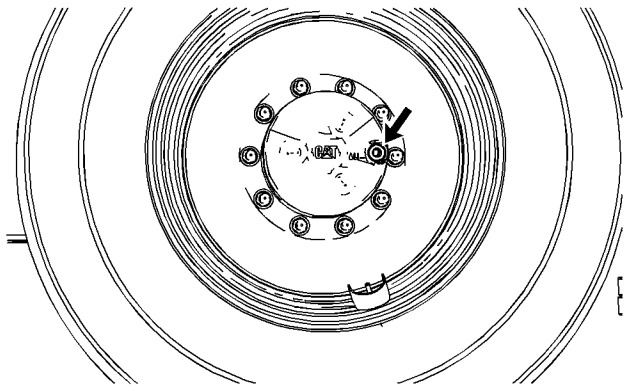

Illustration 264

g01200981

1. Position the oil fill/drain plug at a horizontal position in order to check the oil level.
2. Remove the oil fill/drain plug in order to check the oil level.
3. The oil should be level with the bottom of the plug threads.
4. Clean the plug and install the plug.
5. Repeat the procedure for the other final drive.

i02370039

Final Drive Oil Sample (Front) - Obtain

SMCS Code: 4050-008-FR; 7542-008

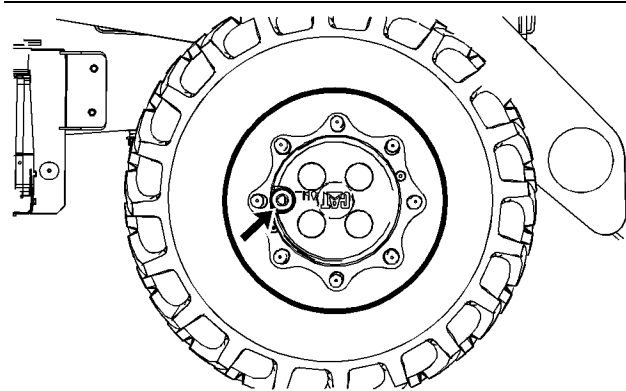

Illustration 265

g01182493

Obtain the oil sample from the fill/drain plug. Refer to Special Publication, SEBU6250, "S-O-S Oil Analysis" for information that pertains to obtaining a sample of the engine oil. Refer to Special Publication, PEHP6001, "How To Take A Good Oil Sample" for more information about obtaining a sample of oil.

i02404432

Final Drive Oil Sample (Rear) - Obtain

SMCS Code: 4050-008-RE; 7542-008

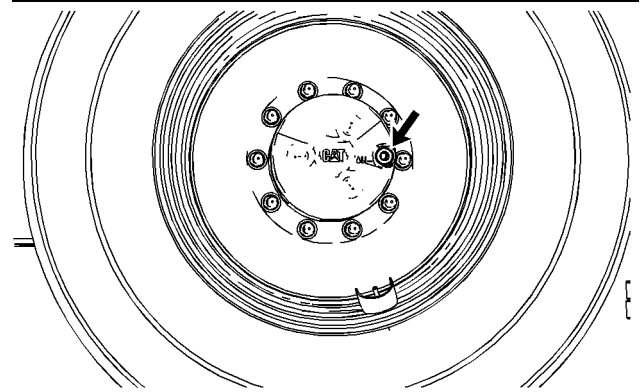

Illustration 266

g01200981

Obtain the oil sample from the fill/drain plug. Refer to Special Publication, SEBU6250, "S-O-S Oil Analysis" for information that pertains to obtaining a sample of the engine oil. Refer to Special Publication, PEHP6001, "How To Take A Good Oil Sample" for more information about obtaining a sample of oil.

i02778910

Fuel System Filter and Water Separator - Replace

SMCS Code: 1261-510; 1263-510-FQ

Some fuel supplies may not meet the minimum standard for fuel lubricity. Caterpillar recommends the use of fuels that meet certain minimum specifications. Refer to Special Publication, SEBU6250, "Caterpillar Machine Fluids Recommendations".

NOTICE

It is extremely important to drain water from the water separator daily, or every ten hours. It is also extremely important to drain water from the fuel tank weekly, or every 50 hours. Failure to do so could result in damage to the fuel system.

i02779217

1. Install the lift cylinder brace. Refer to Operation and Maintenance Manual, "Lift Cylinder Brace - Connect and Disconnect" for more information.
2. Remove the access panel from the left side of the machine.

The machine uses a fuel filter with a push and twist collar.

Note: The primary fuel filter is a reverse flow filter. When you service the machine, the proper filter must be used.

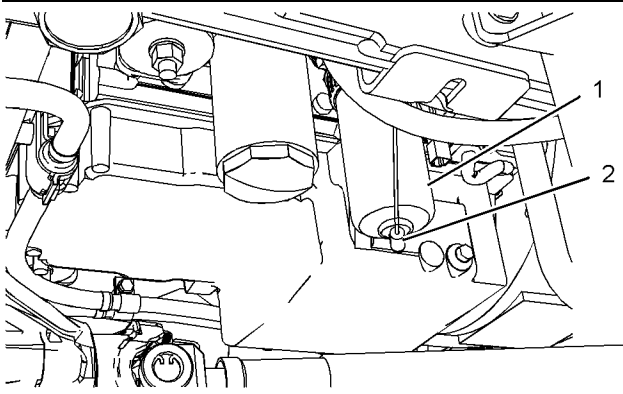

Illustration 267

g01180932

3. Remove sensor (2) and the wire from the bottom of the filter.
4. Remove primary fuel filter (1) that is located next to the engine oil filter under the left side of the machine. Rotate the locking ring counterclockwise in order to remove the filter element. Discard the filter properly.
5. Clean the filter element mounting base. Remove any part of the filter element gasket that remains on the filter element mounting base.
6. Coat the seal of the new filter element with clean diesel fuel.
7. Install the new fuel filter by hand.

Instructions for the installation of the filter are printed on the side of each Caterpillar spin-on filter. For non-Caterpillar filters, refer to the installation instructions that are provided by the supplier of the filter.
8. Install the sensor and the wire into the new filter.
9. Replace the access panel.

Fuel System Secondary Filter - Replace

SMCS Code: 1261-510-SE

S/N: FSH1-Up

S/N: HLS1-Up

S/N: DDT1-Up

S/N: EAT1-Up

S/N: KMW1-Up

NOTICE

Do not fill the secondary fuel filter with fuel before installing. The fuel would not be filtered and could be contaminated. Contaminated fuel will cause accelerated wear to fuel system parts.

NOTICE

Care must be taken to ensure that fluids are contained during performance of inspection, maintenance, testing, adjusting and repair of the product. Be prepared to collect the fluid with suitable containers before opening any compartment or disassembling any component containing fluids.

Refer to Special Publication, NENG2500, "Caterpillar Dealer Service Tool Catalog" for tools and supplies suitable to collect and contain fluids on Caterpillar products.

Dispose of all fluids according to local regulations and mandates.

Note: The secondary fuel filter is a standard flow filter. When you service the machine, the proper filter must be used.

Note: Before you replace the secondary fuel filter, the primary fuel filter must be replaced. Refer to the Operation and Maintenance Manual, "Fuel System Filter and Water Separator - Replace".

1. Park the machine on a level surface. Ensure that the parking brake is fully engaged.

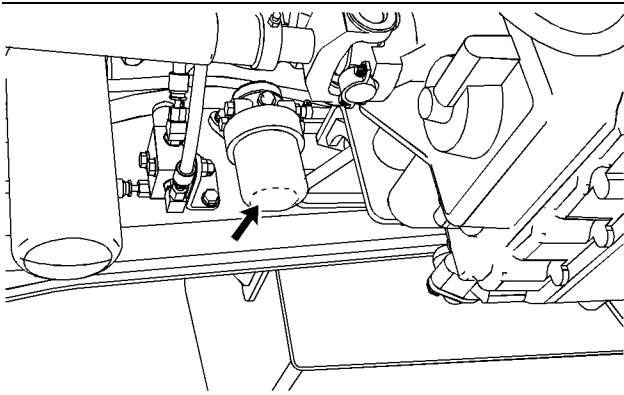

Illustration 268

g01223120

2. Use a strap wrench and remove the secondary fuel filter. Discard the secondary fuel filter properly.
3. Clean the fuel filter base.
4. Coat the seal for the new secondary fuel filter with clean diesel fuel prior to installation.
5. Install the new secondary fuel filter by hand.

Instructions for the installation of the filter are printed on the side of each Caterpillar spin-on filter. For non-Caterpillar filters, refer to the installation instructions that are provided by the supplier of the filter.

6. Start the engine and check for leaks.

i02364753

Fuel System Water Separator - Drain

SMCS Code: 1263-543; 1263

Some fuel supplies may not meet the minimum standard for fuel lubricity. Caterpillar recommends the use of fuels that meet certain minimum specifications. Refer to Special Publication, SEBU6250, "Caterpillar Machine Fluids Recommendations".

NOTICE

It is extremely important to drain water from the water separator daily, or every ten hours. It is also extremely important to drain water from the fuel tank weekly, or every 50 hours. Failure to do so could result in damage to the fuel system.

The water separator is located by the drain plug for the engine crankcase.

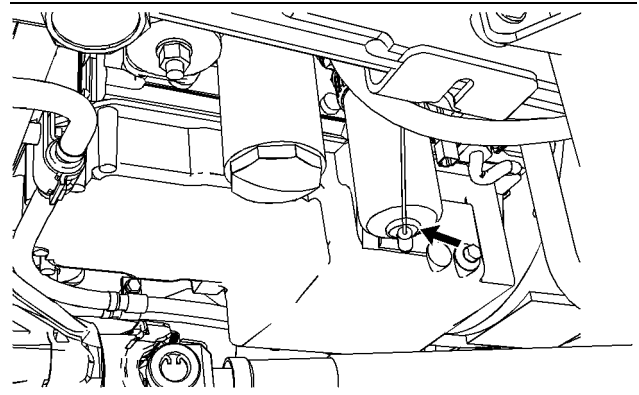

Illustration 269

g01181122

1. Loosen the drain valve on the bottom of the fuel filter. Allow the water and the sediment to drain into a suitable container.
2. Tighten the drain valve.
3. If the engine fails to start, change the fuel filter. If there is a power loss, change the fuel filter.

i02940470

Fuel Tank Water and Sediment - Drain

SMCS Code: 1273-543-M&S

Some fuel supplies may not meet the minimum standard for fuel lubricity. Caterpillar recommends the use of fuels that meet certain minimum specifications. Refer to Special Publication, SEBU6250, "Caterpillar Machine Fluids Recommendations".

NOTICE

It is extremely important to drain water from the water separator daily, or every ten hours. It is also extremely important to drain water from the fuel tank weekly, or every 50 hours. Failure to do so could result in damage to the fuel system.

The fuel tank is located on the left side of the machine.

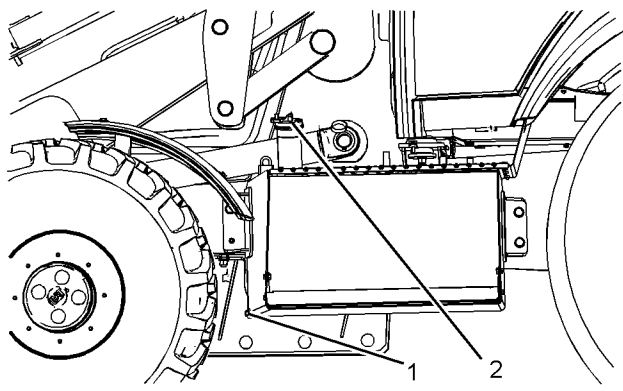

Illustration 270

g01194887

Flip up the tab on the fuel cap. Turn the tab counterclockwise on the fuel cap and slowly remove the fuel tank cap (2) in order to relieve pressure.

The fuel tank drain valve (1) is located on the lower right corner on the front of the fuel tank. Loosen the fuel tank drain plug until the water flows. Allow the water and sediment to drain into a suitable container. Install the fuel tank drain plug. Replace the fuel tank cap.

i02940497

Fuses - Replace

SMCS Code: 1417

Fuses protect the electrical system from damage that is caused by overloaded circuits. Replace the fuse if the element separates. If the element of a new fuse separates, check the circuit. Repair the circuit, if necessary.

NOTICE

Replace the fuses with the same type and size only. Otherwise, electrical damage can result.

If it is necessary to replace fuses frequently, an electrical problem may exist. Contact your Caterpillar dealer

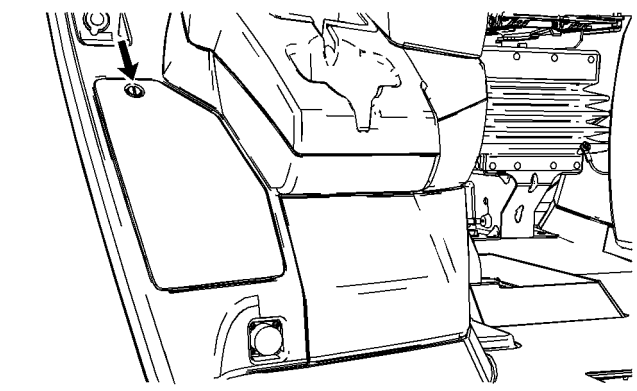

Illustration 271

g01195099

Remove the cover on the front of the right side console in order to access the main fuse panel.

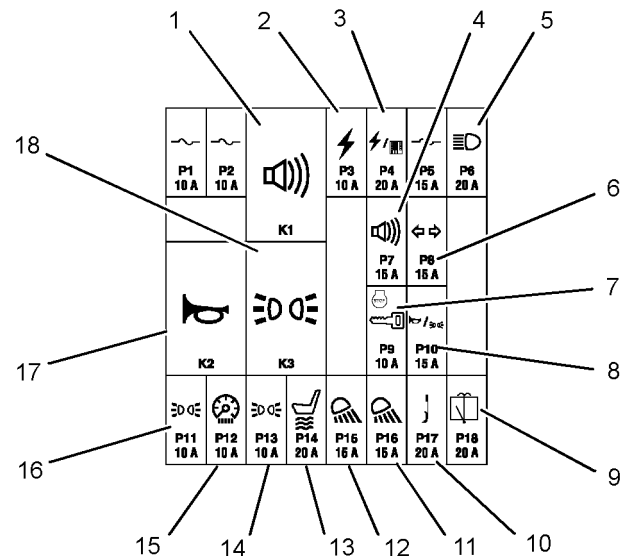

Illustration 272

g01457511

Backup Alarm (1) – Relay

Power Port (2) – 10 Amp

Machine ECM (3) – 20

Backup Alarm (4) – 15 Amp

Rooding Lights (5) – 20 Amp

Flasher Module (6) – 15 Amp

Engine Stop (7) – 10 Amp

Horn and Position Lights (8) – 15 Amp

Rear Window Wiper and Washer (9) – 20 Amp

Laser Mast (10) – 20 Amp

- Rear Floodlights (11) – 15 Amp
 Auxiliary Rear Floodlights (12) – 15 Amp
 Air Seat (13) – 20 Amp
 Left Tail Light (14) – 10 Amp
 Dash Panel Lights (15) – 10 Amp
 Right Tail Light (16) – 10 Amp
 Horn (17) – Relay
 Tail Lights (18) – Relay

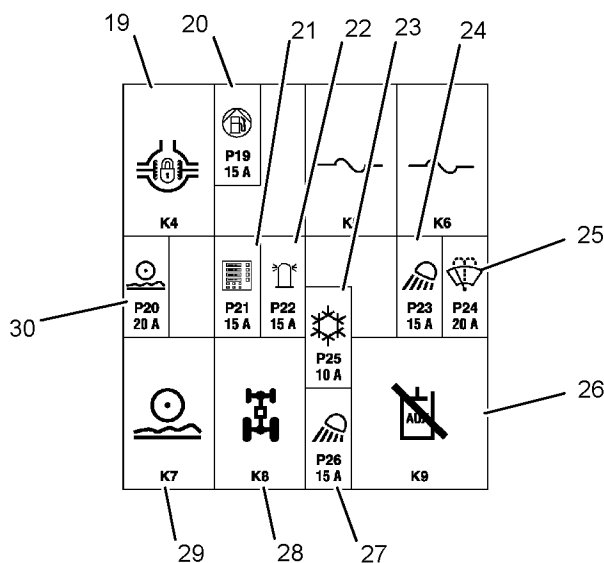

Illustration 273

g01262390

- Differential Lock (19) – Relay
 Fuel Pump (20) – 15 Amp
 Monitor (21) – 5 Amp
 Rotating Beacon (22) – 15 Amp
 Air Conditioner (23) – 10 Amp
 Auxiliary Front Floodlights (24) – 15 Amp
 Front Window Wiper and Washer (25) – 20 Amp
 Hydraulic Lockout (26) – Relay
 Front Floodlights (27) – 15 Amp
 All Wheel Drive (28) – Relay
 Ride Control (29) – Relay

- Ride Control and Hydraulic Lockout (30) – 20 Amp

i02502761

Hydraulic Oil Sample - Obtain

SMCS Code: 5050-008; 7542-008

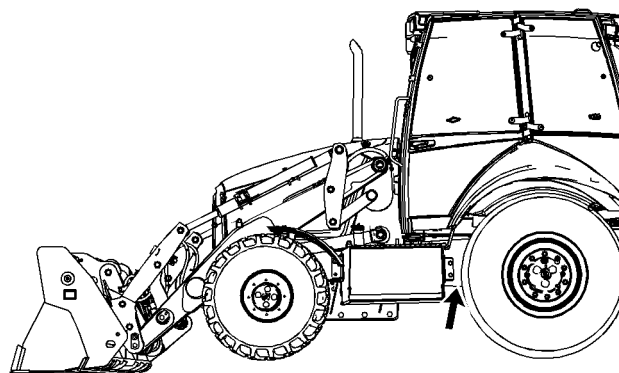

Illustration 274

g01259036

Obtain a sample of the hydraulic oil from the hydraulic quick disconnect fitting that is located on the hydraulic oil filter housing. The hydraulic oil filter housing is located near the rear axle.

1. Turn off the engine.

WARNING

Taking oil samples under a running machine may cause personal injury or death. The use of a sample tube allows an oil sample to be taken while the person is outside of the tread path of the tires. The sample tube should be attached to the sample port when the machine is not running. The oil sample should then be taken only when the following conditions exist:

- The machine transmission is in **NEUTRAL**.
- The parking brake is applied.
- The swing lock pin is engaged.
- All implements are lowered to the ground.
- The hydraulic lockout switch (if equipped) is applied.

2. Attach a hose with a female quick disconnect fitting to the hydraulic quick disconnect fitting.

Note: Ensure that all personnel are clear of the machine before starting the engine.

3. Turn the engine start switch in order to start the engine.
4. Use the hose in order to obtain a sample of the hydraulic oil.

Note: Allow oil to pass through the hose for 10 seconds before obtaining the sample in order to ensure that no contaminants are in the oil sample.

5. Turn off the engine.
6. Remove the hose that was used to obtain the oil sample.

Refer to Special Publication, SEBU6250, "S-O-S Oil Analysis" for information that pertains to a sample of the hydraulic oil. For additional information about taking an oil sample, refer to Special Publication, PEHP6001, "How To Take A Good Oil Sample".

i03150982

Hydraulic System Oil - Change

SMCS Code: 5056

Note: The normal hydraulic oil change interval is at every 2000 Service Hours or 1 Year. By performing S-O-S oil analysis, the hydraulic oil change interval may be extended to 4000 Service Hours or 2 Years. S-O-S oil analysis must be performed at every 500 Service Hours or 3 Months in order to extend the hydraulic oil change interval. The results from the S-O-S oil analysis will determine if the hydraulic oil change interval may be extended. If S-O-S oil analysis is not available, the hydraulic oil change interval must remain at every 2000 Service Hours or 1 Year. Refer to the Operation and Maintenance Manual, "S-O-S Information".

Note: Cat HYDO Advanced 10 has a 50% increase in the standard oil drain interval for machine hydraulic systems (3000 hours versus 2000 hours) over second and third choice oils - when following the maintenance interval schedule for oil filter changes and for oil sampling that is stated in the Operation and Maintenance Manual for your particular machine. 6000 hour oil drain intervals are possible when using S-O-S Services oil analysis. Contact your Cat dealer for details.

Operate the machine for a few minutes in order to warm the hydraulic system oil.

The machine should be level. Lower the bucket to the ground and apply slight downward pressure. Engage the parking brake and stop the engine.

The hydraulic tank filler cap is located under the access door on the top of the engine compartment.

1. Open the engine access door on the top of the machine.

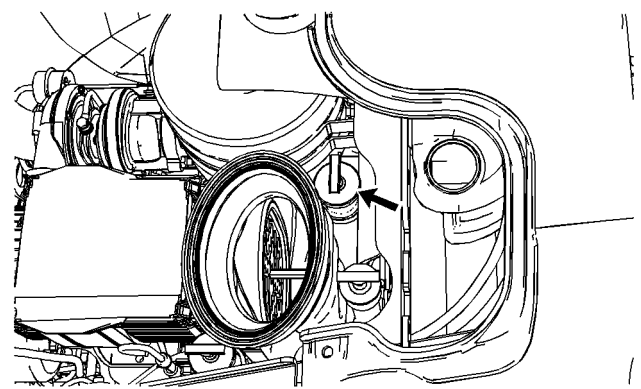

Illustration 275

g01181113

2. Remove the hydraulic tank filler cap.

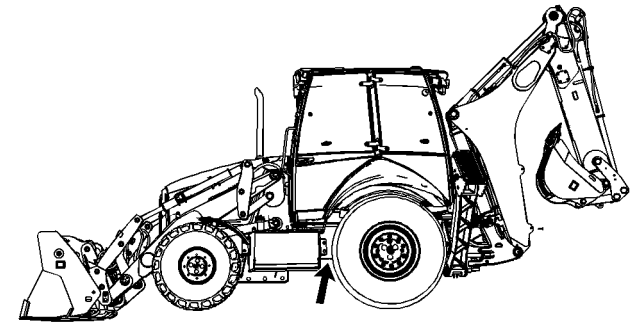

Illustration 276

g01181889

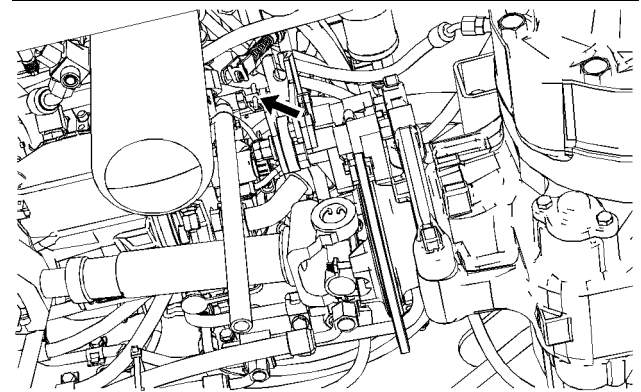

Illustration 277

g01360845

3. Open the drain valve for the hydraulic system. Allow the oil to drain into a suitable container. Close the drain valve.

4. Change the hydraulic system filter. Refer to Operation and Maintenance Manual, "Hydraulic System Oil Filter - Change".
5. Inspect the hydraulic tank breather that is located on a hose from the overflow container. Replace the breather, if necessary.
6. Fill the hydraulic system oil tank. Refer to Operation and Maintenance Manual, "Lubricant Viscosities" and Operation and Maintenance Manual, "Capacities (Refill)".

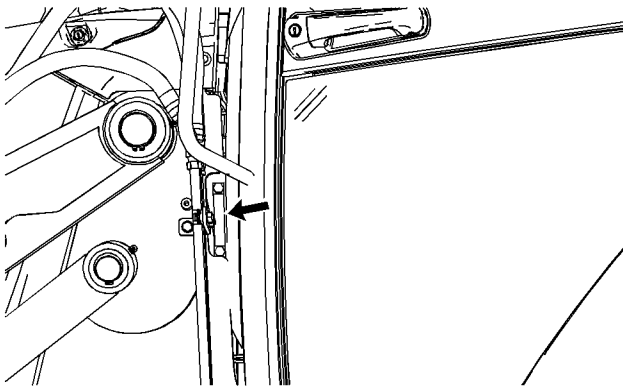

Illustration 278

g01181904

7. Maintain the hydraulic oil level in the sight gauge between the "MIN" mark and the "MAX" mark.

Check the hydraulic oil level with the loader on the ground and with the backhoe in the transport position.

Note: The oil must be free of bubbles. If bubbles are present in the oil, air is entering the hydraulic system. Inspect the suction hoses and hose clamps.

8. Inspect the gasket on the hydraulic tank filler cap for damage. Replace the gasket, if necessary.
9. Install the hydraulic tank filler cap.
10. Close the access door.

i03480268

Hydraulic System Oil Filter - Replace

SMCS Code: 5056; 5068

1. Open the engine access door on the top of the machine.

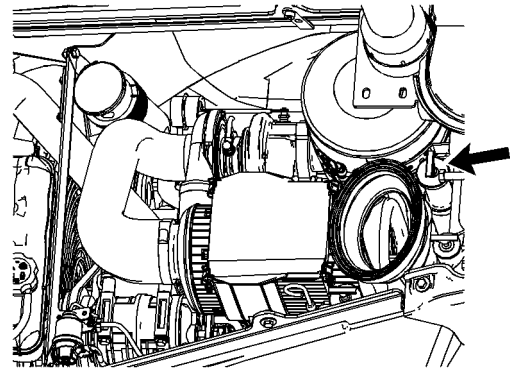

Illustration 279

g01818893

2. Remove the hydraulic tank filler cap that is located under the access panel on the top of the engine compartment.

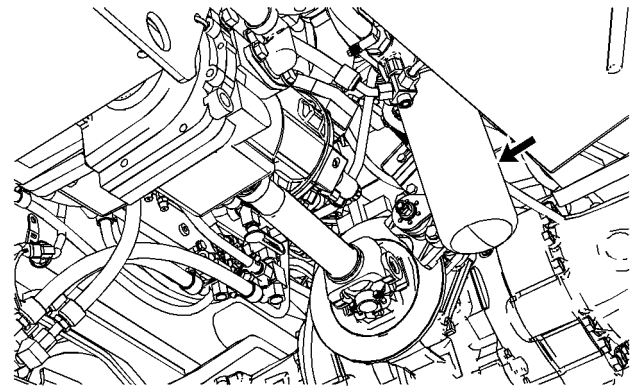

Illustration 280

g01210154

Note: The hydraulic filter is located next to the rear axle.

3. Remove the filter element with a strap type wrench.
4. Clean the filter element mounting base. Remove any part of the filter element gasket that remains on the filter element mounting base.
5. Apply a light coat of oil to the gasket of the new filter element.
6. Install the new oil filter by hand.

Instructions for the installation of the filter are printed on the side of each Caterpillar spin-on filter. For non-Caterpillar filters, refer to the installation instructions that are provided by the supplier of the filter.

7. Remove the hydraulic tank breather. Replace the old breather with a new breather.

i03397201

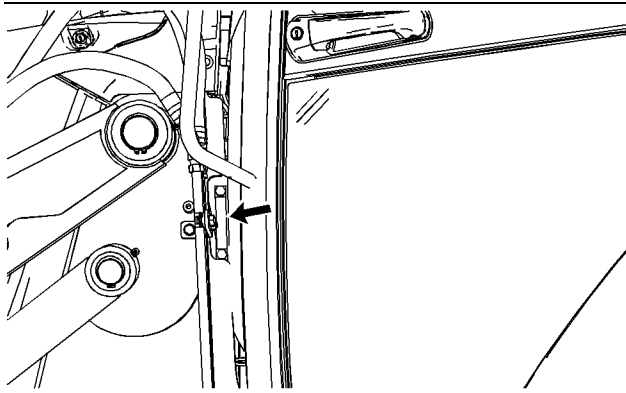

Illustration 281

g01181904

8. Maintain the hydraulic oil level in the sight gauge between the "MIN" mark and the "MAX" mark. Add oil, if necessary.
9. Inspect the gasket on the hydraulic tank filler cap for damage. Replace the gasket, if necessary.
10. Install the hydraulic tank filler cap.
11. Close the access door.

i02368450

Hydraulic System Oil Level - Check

SMCS Code: 5056; 7479

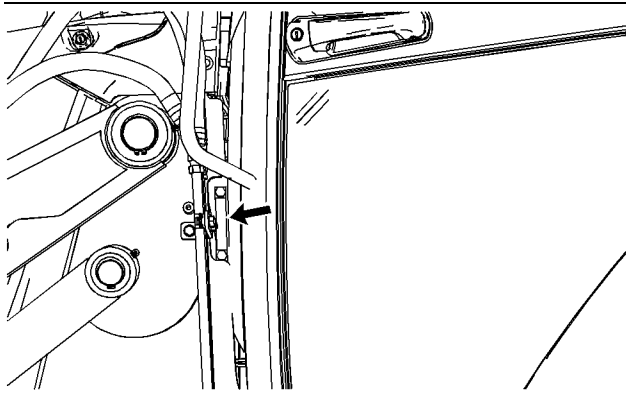

Illustration 282

g01181904

The sight gauge for the hydraulic tank is located on the left side of the machine. Move the backhoe to the transport position and lower the loader bucket to the ground.

Turn off the engine. Wait about five minutes before you check the hydraulic system oil level.

Maintain the oil level in the sight gauge between the "MIN" mark and the "MAX" mark.

Loader Bucket, Cylinder, and Linkage Bearings - Lubricate

SMCS Code: 7069; 7070; 7071

Single Tilt Machines

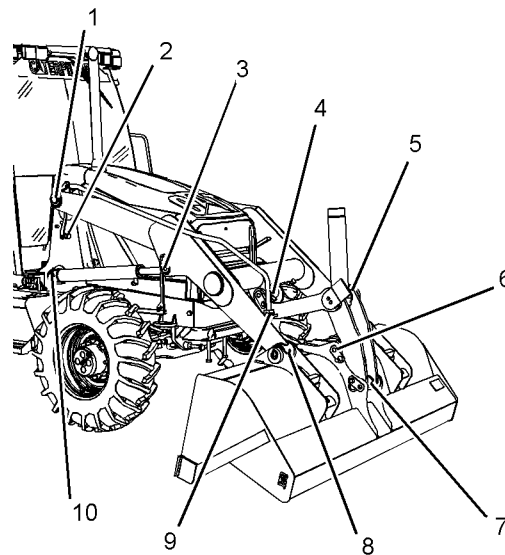

Illustration 283

g01203892

Apply lubricant to the grease fittings (1) for the frame and for the lift arm. There is a grease fitting for each side of the machine.

Apply lubricant to the grease fitting (2) for the pivot for the linkage of bucket positioner and lift kickout.

Apply lubricant to the grease fittings (3) for the rod end of the lift cylinder. There is a grease fitting for each side of the machine.

Apply lubricant to the grease fittings (4) for the pivot pin at the loader lift arm. There is a grease fitting for each side of the machine.

Apply lubricant to the grease fittings (5) for the pivot bearings for the bucket tilt cylinder. There is a grease fitting in each linkage (four total).

Apply lubricant to the grease fitting (6) for the rod end of the tilt cylinder.

Apply lubricant to the grease fittings (7) for the upper pivot pin. There is a grease fitting for each side of the machine.

Apply lubricant to the grease fittings (8) for the lower pivot pins. There is a grease fitting for each side of the machine.

Apply lubricant to the grease fitting (9) for the pivot for the linkage of bucket positioner and lift kickout.

Apply lubricant to the grease fittings (10) for the head end of the lift cylinder. There is a grease fitting for each side of the machine.

There is a total of 18 grease fittings.

Open the engine access door on the top of the machine.

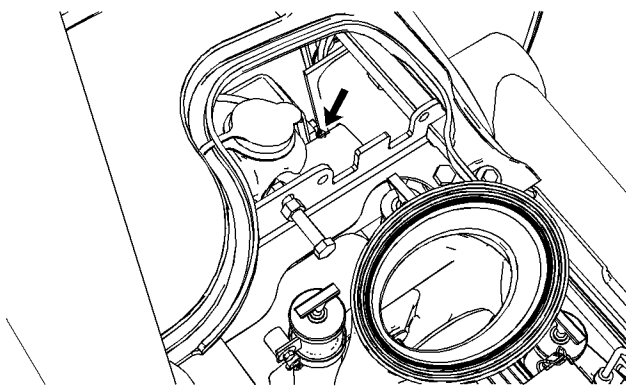

Illustration 284

g01758234

Apply lubricant to the grease fitting for the pivot point for the lift arms.

Parallel Lift Machines

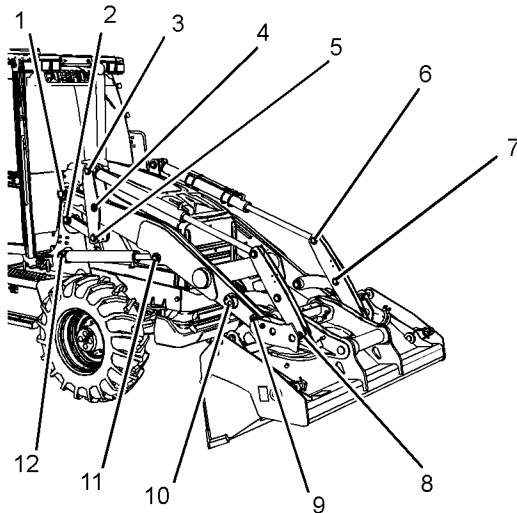

Illustration 285

g01253459

Apply lubricant to the grease fittings (1) for the frame and for the lift arm. There is a grease fitting for each side of the machine.

Apply lubricant to the grease fittings (2) for the frame and for the parallel linkage. There is a grease fitting for each side of the machine.

Apply lubricant to the grease fittings (3) for the head end of the tilt cylinder. There is a grease fitting for each side of the machine.

Apply lubricant to the grease fittings (4) for the center pivot pin of the parallel linkage. There is a grease fitting for each side of the machine.

Apply lubricant to the grease fittings (5) for the lower pivot pin of the parallel linkage. There is a grease fitting for each side of the machine.

Apply lubricant to the grease fittings (6) for the rod end of the tilt cylinder. There is a grease fitting for each side of the machine.

Apply lubricant to the grease fittings (7) for the upper pivot pin of the tilt linkage. There is a grease fitting for each side of the machine.

Apply lubricant to the grease fittings (8) for the upper pivot pin of the quick coupler assembly. There is a grease fitting for each side of the machine.

Apply lubricant to the grease fittings (9) for the lower pivot pin of the quick coupler assembly. There is a grease fitting for each side of the machine.

Apply lubricant to the grease fittings (10) for the lower pivot pin of the tilt linkage. There is a grease fitting for each side of the machine.

Apply lubricant to the grease fittings (11) for the rod end of the lift cylinder. There is a grease fitting for each side of the machine.

Apply lubricant to the grease fittings (12) for the head end of the lift cylinder. There is a grease fitting for each side of the machine.

There is a total of 24 grease fittings.

Multi Purpose Bucket

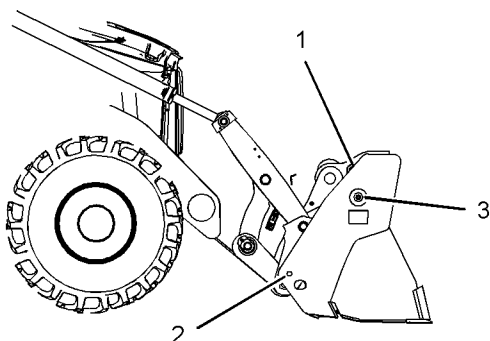

Illustration 286

g01495053

Apply lubricant to the grease fittings (1) for the rod end of the lift cylinder. There is a grease fitting for each side of the bucket.

Apply lubricant to the grease fittings (2) for the head end of the lift cylinder. There is a grease fitting for each side of the bucket.

Apply lubricant to the grease fittings (3) for the bucket hinge pin. There is a grease fitting for each side of the bucket.

There is a total of six grease fittings.

i02106227

Oil Filter - Inspect

SMCS Code: 1318; 3067; 5068

Inspect a Used Filter for Debris

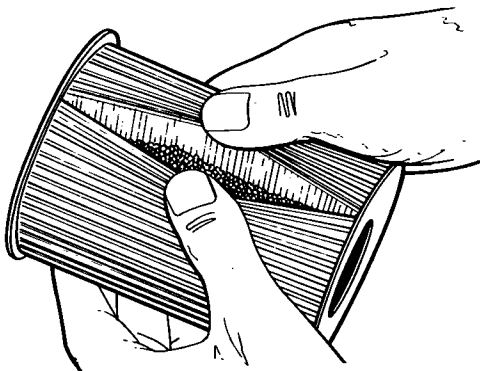

Illustration 287

g00100013

The element is shown with debris.

Use a filter cutter to cut the filter element open. Spread apart the pleats and inspect the element for metal and for other debris. An excessive amount of debris in the filter element can indicate a possible failure.

If metals are found in the filter element, a magnet can be used to differentiate between ferrous metals and nonferrous metals.

Ferrous metals can indicate wear on steel parts and on cast iron parts.

Nonferrous metals can indicate wear on the aluminum parts of the engine such as main bearings, rod bearings, or turbocharger bearings.

Small amounts of debris may be found in the filter element. This could be caused by friction and by normal wear. Consult your Caterpillar dealer in order to arrange for further analysis if an excessive amount of debris is found.

Using an oil filter element that is not recommended by Caterpillar can result in severe engine damage to engine bearings, to the crankshaft, and to other parts. This can result in larger particles in unfiltered oil. The particles could enter the lubricating system and the particles could cause damage.

i02368709

Parking Brake - Check/Adjust

SMCS Code: 4267

Check Procedure

Check the area around the machine. Make sure that the machine is clear of personnel and clear of obstacles.

Check the brakes on a dry, level surface.

Fasten the seat belt before you check the brakes.

The following checks are used to determine if the parking brake is functional. These checks are not intended to measure the maximum brake holding effort. The brake holding effort that is required to sustain a machine at a specific engine rpm varies depending on the machine. The variations are the differences in the engine setting, in the power train efficiency, and in the brake holding ability, etc.

1. Start the engine. Raise the bucket slightly.

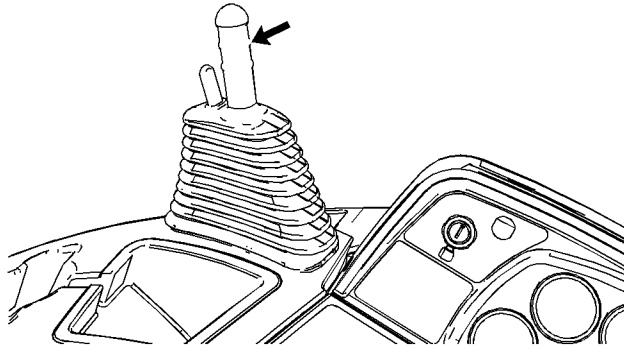

Illustration 288

g01182047

2. Engage the parking brake.
3. If the machine is equipped with the direct drive transmission, move the transmission speed shift lever to THIRD gear. Move the transmission direction control lever to FORWARD, to NEUTRAL, and back to FORWARD. If the machine is equipped with a power shift transmission move the transmission control lever to THIRD SPEED FORWARD, to NEUTRAL, and back to THIRD SPEED FORWARD. This is done in order to override the transmission neutralizer for this test.

Note: Place machines that are equipped with all wheel drive into two-wheel drive mode.

Note: The parking brake indicator light should come on and the parking brake alarm should sound.

4. Gradually increase the engine speed to high idle. The machine should not move.

WARNING

If the machine begins to move, reduce the engine speed immediately and apply the service brake pedal.

5. Reduce the engine speed. Move the transmission to NEUTRAL. Lower the bucket to the ground. Stop the engine.

Adjustment Procedure

If the machine moved during the test, perform the following procedure in order to adjust the parking brake.

1. Apply the service brakes.
2. Disengage the parking brake.

3. As you view the parking brake adjuster knob from the operator seat, turn the knob clockwise for one half of a turn.

4. Repeat steps 1 to 5 in the check procedure.

If the machine moves during the parking brake test, then perform the adjustment procedure again. If you run out of adjustment on the parking brake adjuster knob, refer to Systems Operation, Testing and Adjusting, "Parking Brake Control - Adjust" for your machine.

i02500940

Power Sideshift Stabilizer Wear Pads - Inspect (If Equipped)

SMCS Code: 7222-040-JP

S/N: BXE1-Up

S/N: LBE1-Up

S/N: FSH1-Up

S/N: GKZ1-Up

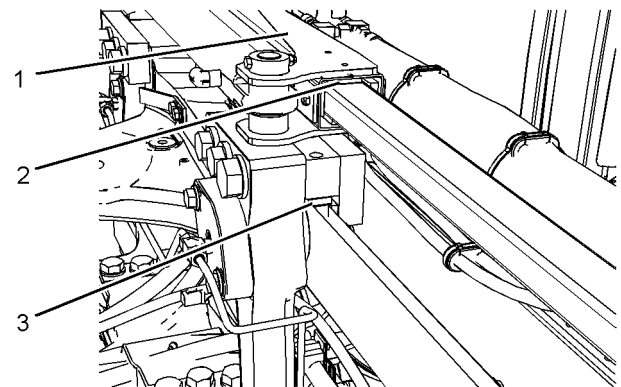

Illustration 289

g01222012

1. Inspect eight pads (2). There are four pads on each end of link (1). The minimum thickness for pads (2) is 9.5 mm (0.37 inch).
2. Inspect four pads (3). There are two pads on each side of the slide frame. The minimum thickness for pads (3) is 12.5 mm (0.49 inch).
3. If replacement of the pads is required, please see your Caterpillar dealer.

i02514305

i02723802

Radiator Core - Clean

SMCS Code: 1353

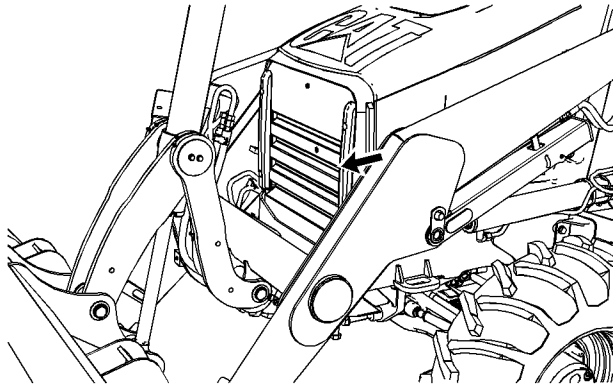

Illustration 290

g01257883

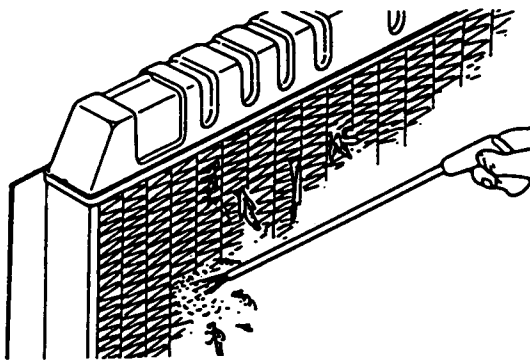

Illustration 291

g00101939

NOTICE

Do not spray high pressure water into the radiator while the engine is running.

You can use compressed air, high pressure water, or steam to remove dust and other debris from the radiator fins. However, the use of compressed air is preferred.

Note: If necessary, tilt the oil cooler away from the radiator in order to remove dust and debris between the radiator and the oil cooler.

Note:

Receiver Dryer (Refrigerant) - Replace

SMCS Code: 7322-710

! WARNING

Personal injury can result from contact with refrigerant.

Contact with refrigerant can cause frost bite. Keep face and hands away to help prevent injury.

Protective goggles must always be worn when refrigerant lines are opened, even if the gauges indicate the system is empty of refrigerant.

Always use precaution when a fitting is removed. Slowly loosen the fitting. If the system is still under pressure, release it slowly in a well ventilated area.

Personal injury or death can result from inhaling refrigerant through a lit cigarette.

Inhaling air conditioner refrigerant gas through a lit cigarette or other smoking method or inhaling fumes released from a flame contacting air conditioner refrigerant gas, can cause bodily harm or death.

Do not smoke when servicing air conditioners or wherever refrigerant gas may be present.

Use a certified recovery and recycling cart to properly remove the refrigerant from the air conditioning system.

NOTICE

If the refrigerant system has been open to the outside air (without being plugged) for more than 30 minutes, the receiver-dryer must be replaced. Moisture will enter an open refrigerant system and cause corrosion which will lead to component failure.

Refer to Service Manual, SENR5664, "Air Conditioning and Heating System with R-134a Refrigerant for All Caterpillar Machines" for the proper procedure to change the receiver-dryer assembly and for the procedure to reclaim the refrigerant gas.

i03329202

Rollover Protective Structure (ROPS) - Inspect

SMCS Code: 7325

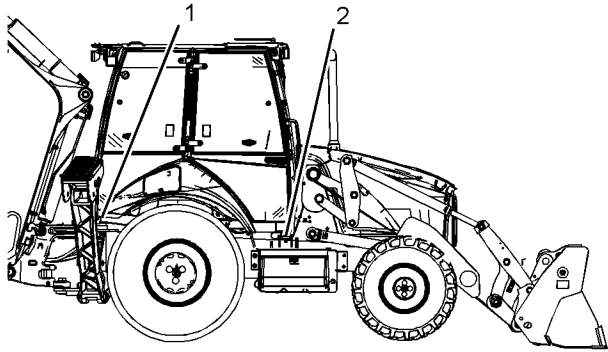

Illustration 292

g01182084

1. Inspect the ROPS for loose bolts or for damaged bolts. Replace any damaged bolts or missing bolts with original equipment parts only.

Tighten the M20 bolts (1) to a torque of 460 ± 60 N·m (339 ± 44 lb ft). Tighten the M16 bolts (2) to a torque of 240 ± 40 N·m (177 ± 30 lb ft).

Note: Apply oil to all ROPS bolt threads before you install the bolts. Failure to apply oil to the bolt threads can result in improper bolt torque.

2. Operate the machine on a rough surface. Replace the ROPS mounting supports if the ROPS emits a noise. Replace the ROPS mounting supports if the ROPS rattles.

Do not straighten the ROPS. Do not repair the ROPS by welding reinforcement plates to the ROPS.

Consult your Caterpillar dealer for repair of any cracks in the ROPS.

i02429589

Seat Belt - Inspect

SMCS Code: 7327-040

Always check the condition of the seat belt and the condition of the seat belt mounting hardware before you operate the machine. Replace any parts that are damaged or worn before you operate the machine.

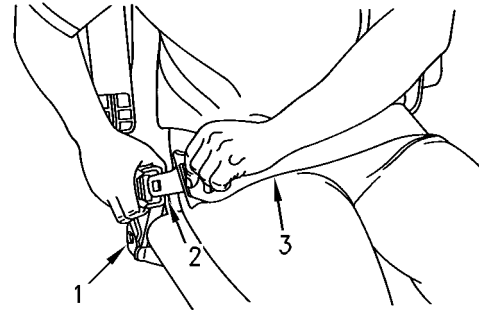

Illustration 293

g00932801

Typical example

Check the seat belt mounting hardware (1) for wear or for damage. Replace any mounting hardware that is worn or damaged. Make sure that the mounting bolts are tight.

Check buckle (2) for wear or for damage. If the buckle is worn or damaged, replace the seat belt.

Inspect the seat belt (3) for webbing that is worn or frayed. Replace the seat belt if the seat belt is worn or frayed.

Consult your Caterpillar dealer for the replacement of the seat belt and the mounting hardware.

Note: Within three years of the date of installation or within five years of the date of manufacture, replace the seat belt. Replace the seat belt at the date which occurs first. A date label for determining the age of the seat belt is attached to the seat belt, the seat belt buckle, and the seat belt retractor.

If your machine is equipped with a seat belt extension, also perform this inspection procedure for the seat belt extension.

i02429594

Seat Belt - Replace

SMCS Code: 7327-510

Within three years of the date of installation or within five years of the date of manufacture, replace the seat belt. Replace the seat belt at the date which occurs first. A date label for determining the age of the seat belt is attached to the seat belt, the seat belt buckle, and the seat belt retractor.

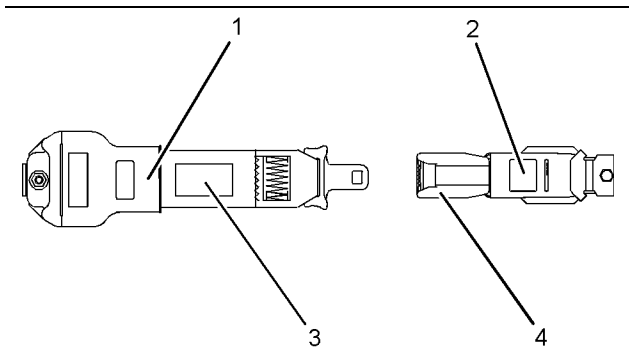

Illustration 294

g01152685

- (1) Date of installation (retractor)
- (2) Date of installation (buckle)
- (3) Date of manufacture (tag) (fully extended web)
- (4) Date of manufacture (underside) (buckle)

Consult your Caterpillar dealer for the replacement of the seat belt and the mounting hardware.

If your machine is equipped with a seat belt extension, also perform this replacement procedure for the seat belt extension.

i02409961

Sideshift Stabilizer Wear Pads - Inspect/Adjust

SMCS Code: 7222-025-JP; 7222-040-JP

S/N: BXE1-Up

S/N: LBE1-Up

S/N: FSH1-Up

S/N: GKZ1-Up

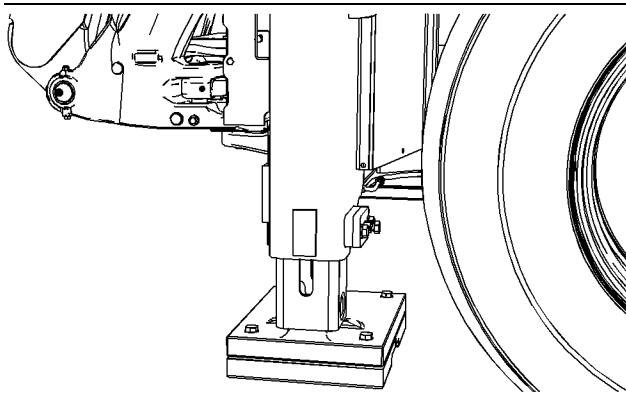

Illustration 295

g01205831

1. Lower the stabilizers until the feet are just above the ground.

2. Check the stabilizer legs for movement in both directions. Maximum free play is 1 mm (0.0394 inch). If adjustment is needed, perform the following steps:

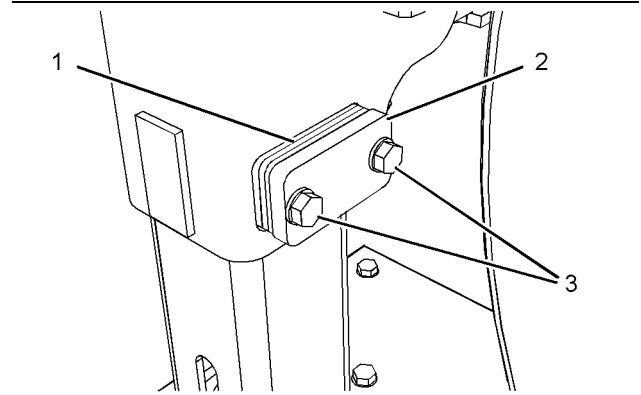

Illustration 296

g01221682

- a. Remove two bolts (3).
- b. Remove plate (2).
- c. Remove shims (1) in order to maintain maximum free play.

Note: Each shim is 1 mm (0.0394 inch) in thickness.

- d. Replace plate (2) and bolts (3).

3. Repeat steps 2.a through 2.d for the remaining wear pads.

4. Fully retract the stabilizers before moving the machine.

The stabilizer pads do not normally require any lubrication. If the stabilizers become noisy, a small amount of a silicone based lubricant may be applied.

Note: Do not apply an excessive amount of a silicone based lubricant. Dirt can be attracted to the lubricant and dirt can cause abrasion to the pad assemblies and wear to the pad assemblies.

i02413953

Stabilizer - Clean/Inspect

SMCS Code: 7222-040; 7222-070

1. Lower the stabilizer legs.

i02348180

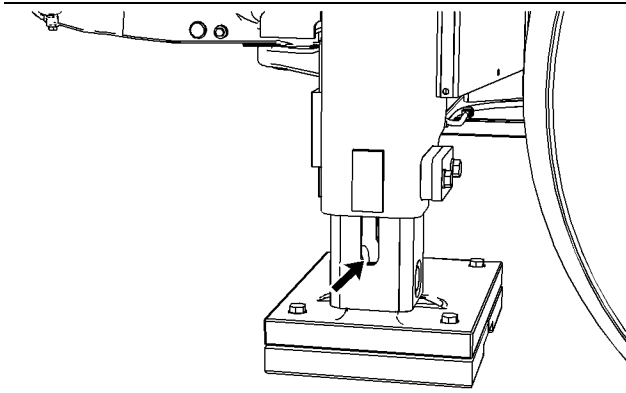

Illustration 297

g01206607

2. Inspect the inner leg through the slot in the leg.
3. Remove excessive debris with pressurized water. Remove dry debris with a long tool.

i02409048

Stabilizer and Cylinder Bearings - Lubricate

SMCS Code: 5468; 7222

S/N: HLS1-Up

S/N: DDT1-Up

S/N: EAT1-Up

S/N: KMW1-Up

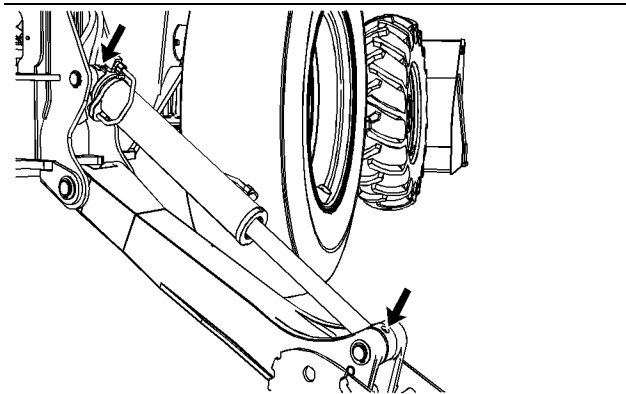

Illustration 298

g01203780

Position the stabilizer, as shown.

Apply lubricant to the grease fitting for the head end of the cylinder and the rod end of the cylinder.

Repeat for the other stabilizer.

There is a total of four grease fittings.

Swing Frame and Cylinder Bearings - Lubricate

SMCS Code: 5105; 6506; 6507; 7063

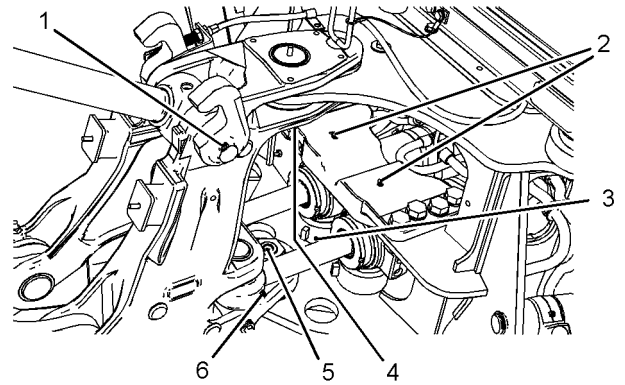

Illustration 299

g01182221

Apply lubricant to the grease fitting (1) for the boom lock. Repeat for the opposite side.

Apply lubricant to the grease fittings (2) for the bearing on the top of the swing cylinders.

Apply lubricant to the grease fitting (3) for the bearing on the bottom of the swing cylinder. Repeat for the other swing cylinder.

Apply lubricant to the grease fitting (4) for the top swing pin.

Apply lubricant to the grease fitting (5) for the bottom swing pin.

Apply lubricant to the grease fitting (6) for the eye of the swing cylinder. Repeat for the other swing cylinder.

There is a total of ten grease fittings.

i02369786

Tire Inflation - Check

SMCS Code: 4203

Measure the tire pressure on each tire. Tire inflation pressures for each application may vary. These tire inflation pressures should be obtained from your tire supplier.

Inflate the tires, if necessary. Refer to Operation and Maintenance Manual, "Tire Inflation with Air".

The operating pressure is based on the following conditions.

- The weight of a ready-to-work machine at the front tires and at the rear tires
- The rated payload
- Average operating conditions

Contact your tire supplier if your machine is experiencing tire slippage. Tire wear may cause tire slippage.

i01365052

Transmission Magnetic Screen - Clean

SMCS Code: 3030

1. Drain the transmission oil. Refer to Operation and Maintenance Manual, "Transmission Oil - Change".

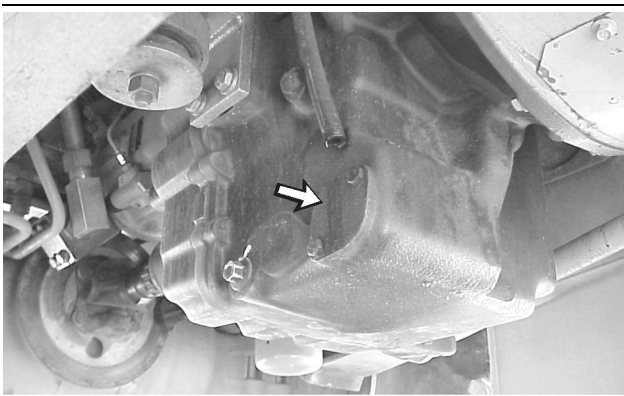

Illustration 300
Magnetic strainer cover for the standard transmission

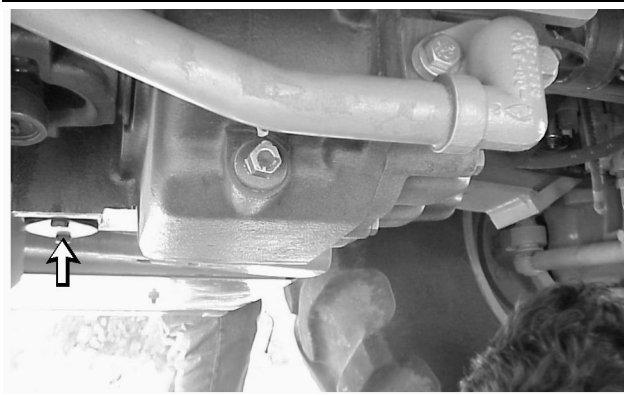

Illustration 301
Magnetic strainer cover for the power shift transmission

2. Remove the magnetic strainer cover.
3. Remove the magnets from the housing.

4. Remove the screen from the housing.
5. Wash the tube and the screen in a clean, nonflammable solvent.

NOTICE

Do not drop or rap the magnets against any hard objects. Replace any damaged magnets.

6. Clean the magnets with a cloth, with a stiff bristle brush, or with pressure air.
7. Install the magnets and the tube assembly into the magnetic screen.
8. Install the magnetic screen.
9. Clean the cover and inspect the seal. Replace the seal, if the seal is damaged.
10. Install the cover. Tighten the cover bolts.
11. Fill the transmission. Refer to Operation and Maintenance Manual, "Transmission Oil - Change".

i03007392

Transmission Oil - Change

SMCS Code: 3030; 3080

Operate the machine for a few minutes in order to warm the transmission oil.

The machine should be level. Lower the bucket to the ground and apply slight downward pressure. Engage the parking brake and stop the engine.

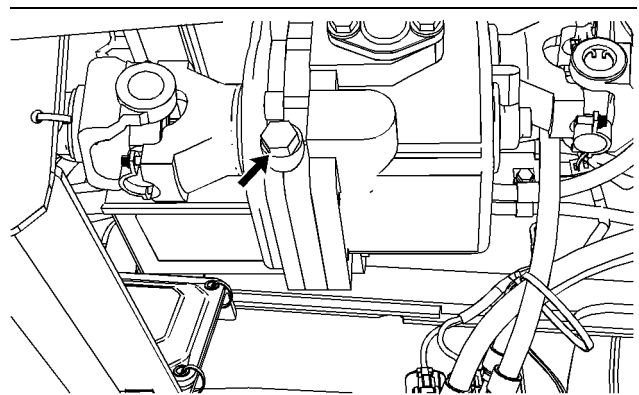

Illustration 302
Drain plug for direct drive transmission

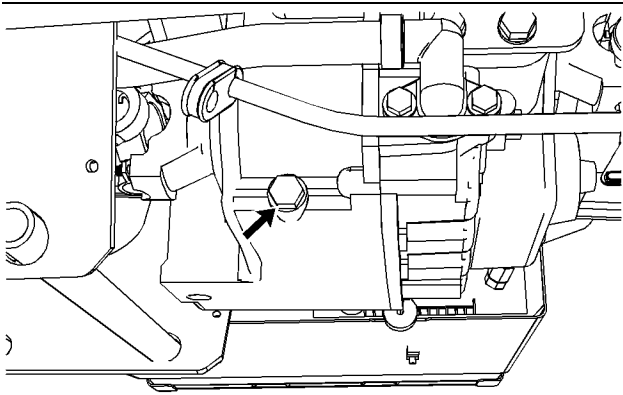

Illustration 303

g01204398

Drain plug for power shift transmission

1. Remove the transmission drain plug. Allow the transmission oil to drain into a suitable container. Clean the transmission drain plug and install the transmission drain plug.
2. Change the transmission oil filter element. Refer to Operation and Maintenance Manual, "Transmission Oil Filter - Replace".
3. Clean the transmission magnetic screen. Refer to Operation and Maintenance Manual, "Transmission Magnetic Screen - Clean".

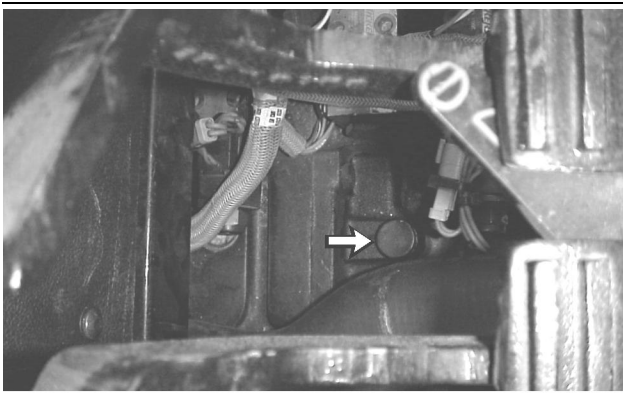

Illustration 304

g00725462

4. Remove the transmission breather from the top of the transmission case. Clean the breather in clean nonflammable solvent and allow the breather to dry. Replace the breather.
5. Open the engine access door on the top of the machine.

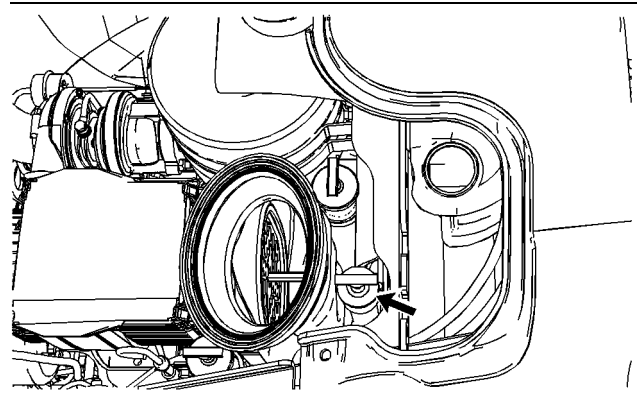

Illustration 305

g01182357

6. Remove the dipstick/fill cap and fill the transmission with transmission oil. Refer to Operation and Maintenance Manual, "Lubricant Viscosities" and Operation and Maintenance Manual, "Capacities (Refill)".
 7. Start the engine and run the engine at low idle. Apply the service brake. Slowly operate the transmission controls in order to circulate the oil.
 8. Move the transmission control lever to NEUTRAL and engage the parking brake. Inspect the transmission for leaks.
 9. Maintain the transmission oil level within the crosshatched region on the "CHECK WITH OIL WARM" side of the dipstick when the transmission is warm. Add transmission oil through the transmission filler tube, if necessary.
- Note:** The transmission can be checked with cold transmission oil. Ensure that the oil level is within the crosshatched region on the "Safe to Start" side of the dipstick/fill plug. Add transmission oil, if necessary.
10. Install the dipstick/fill cap and install the engine access door.
 11. Stop the engine.

i03480364

Transmission Oil Filter - Replace

SMCS Code: 3067

The transmission filter is located on the left side of the machine .

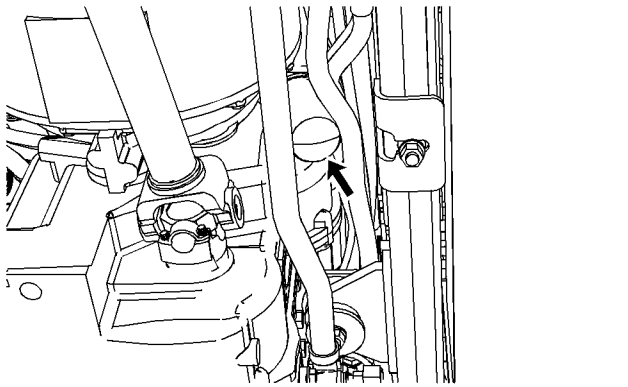

Illustration 306

g01182353

1. Remove the transmission oil filter element with a strap type wrench.
2. Clean the filter element mounting base. Remove any part of the filter element gasket that remains on the filter element mounting base.
3. Apply a light coat of oil to the gasket of the new filter element.
4. Install the new oil filter by hand.

Instructions for the installation of the filter are printed on the side of each Caterpillar spin-on filter. For non-Caterpillar filters, refer to the installation instructions that are provided by the supplier of the filter.

5. Start the engine and apply the service brake. Slowly operate the transmission controls in order to circulate the transmission oil.
6. Move the transmission control lever to NEUTRAL and engage the parking brake. Inspect the filter element for leaks.

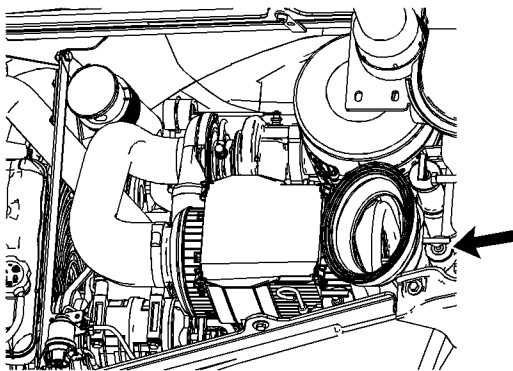

Illustration 307

g01818934

7. Check the transmission oil level. Refer to Operation and Maintenance Manual, "Transmission Oil Level - Check" for more information.
8. Stop the engine.

i03480366

Transmission Oil Level - Check

SMCS Code: 3030; 3080; 3081

Check the transmission oil level while the machine is on a level surface. The loader should be resting on the ground.

1. Open the engine access door on the top of the machine.

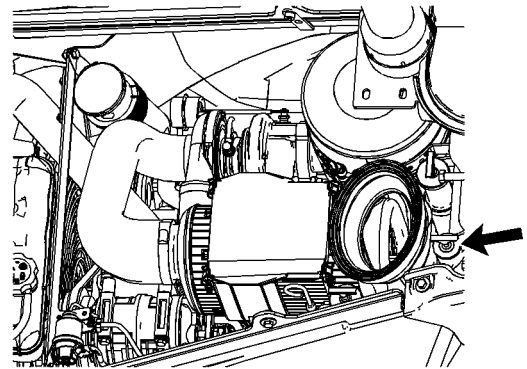

Illustration 308

g01818934

2. Remove the dipstick/fill plug for the transmission.
3. Ensure that the oil level is within the crosshatched region on the "Safe To Start" side of the dipstick/fill plug. Add transmission oil, if necessary.
4. Start the engine. Run the engine for 5 minutes.
5. Maintain the oil level within the crosshatched region on the "CHECK WITH WARM OIL" side of the dipstick/fill plug when the transmission is warm and the engine is at low idle. Add transmission oil, if necessary.
6. Clean the dipstick/fill plug and install the dipstick/fill plug.

i03480361

i01986834

Transmission Oil Sample - Obtain

SMCS Code: 3030-008; 7542-008

NOTICE

Care must be taken to ensure that fluids are contained during performance of inspection, maintenance, testing, adjusting and repair of the product. Be prepared to collect the fluid with suitable containers before opening any compartment or disassembling any component containing fluids.

Refer to Special Publication, NENG2500, "Caterpillar Dealer Service Tool Catalog" for tools and supplies suitable to collect and contain fluids on Caterpillar products.

Dispose of all fluids according to local regulations and mandates.

WARNING

Hot oil and hot components can cause personal injury. Do not allow hot oil or hot components to contact skin.

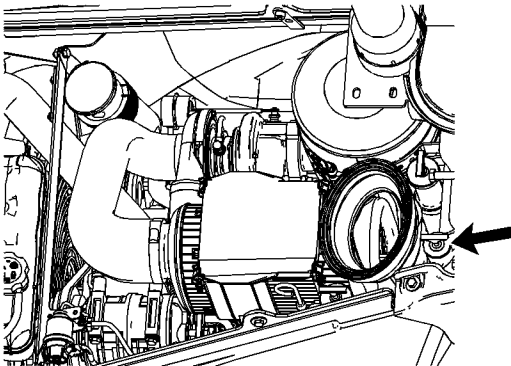

Illustration 309

g01818934

Obtain a sample of the transmission oil from the transmission oil filler tube.

Refer to Special Publication, SEBU6250, "S-O-S Oil Analysis" for information that pertains to obtaining a sample of the transmission oil. Refer to Special Publication, PEHP6001, "How To Take A Good Oil Sample" for more information about obtaining a sample of the transmission oil.

Wheel Bearings (Front) - Lubricate (Two-Wheel Drive)

SMCS Code: 4205; 4208

Use the following procedure for both wheels.

1. Raise the front wheels slightly off the ground.
2. Install sufficient blocking under the frame and lower the machine to the blocking.
3. Remove the nuts and both wheels.

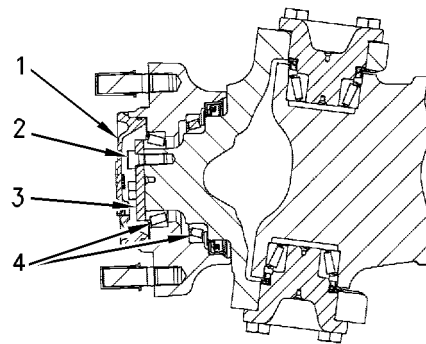

Illustration 310

g00976070

4. Remove the dust cap (1).
5. Remove bolts (2) and retaining plate (3).
6. Pull the hub assembly (4) until the cone and roller assembly come out of the hub assembly. Then, pull off the hub all the way.
7. Clean all of the parts in clean, nonflammable solvent and allow the parts to air dry. Do not use pressure air.
8. Inspect the roller assemblies for heat discoloration and for wear. Inspect the seals for damage. Replace any damaged parts.
9. Make sure that the grease gets packed between the rollers and the cage on both bearings.

Force the grease through the bearing from the large end of the rollers.
10. Pack a 6 mm (0.25 inch) layer of grease between the bearing assemblies in the hub. Do not pack the hub fully with grease.
11. Apply a 6 mm (0.25 inch) thick film of grease on the spindle surface.

12. Install the hub, the bearings, the washer, the nut and the wheel.
13. While you turn the wheel, tighten bolt (2) until a slight drag is noticed.
14. All bearing surfaces must make contact. The wheel should turn freely within 0.025 to 0.25 mm (0.001 to 0.010 inch) end play.
15. Install the dust cap.

i02525863

Wheel Nut Torque - Check

SMCS Code: 4051; 4199; 4200

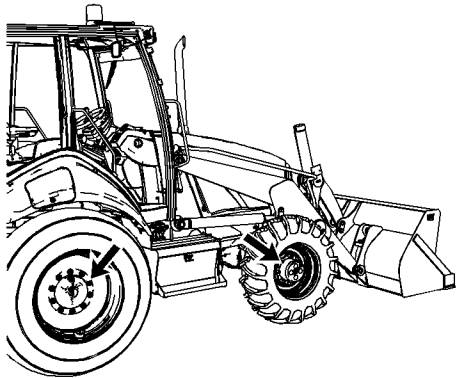

Illustration 311

g01263488

Check the torque on new wheels or repaired wheels after every ten service hours until the specified torque is maintained.

The nut and the stud should be clean and dry for reassembly. Apply one drop of lubricating oil to the stud before installing the nut onto the stud.

Torque the nuts to 460 ± 60 N·m (339 ± 44 lb ft). Use a star pattern when you torque the nuts.

Check the nuts on all four wheels.

i03480604

Window Washer Reservoir - Fill

SMCS Code: 7306-544

NOTICE

When operating in freezing temperatures, use Caterpillar or any commercially available nonfreezing window washer solvent.

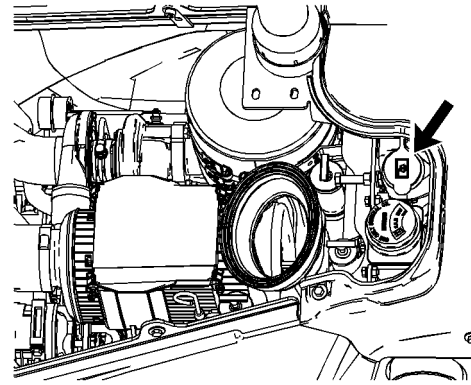

Illustration 312

g01819233

The washer fluid bottle is located in the engine compartment.

1. Open the engine access door.
2. Remove the filler cap.
3. Fill the washer fluid bottle with washer fluid through the filler opening.
4. Replace the filler cap.
5. Close the engine access door.

i01437556

Window Wipers - Inspect/Replace

SMCS Code: 7305

Inspect the condition of the wiper blades. Replace the wiper blades if the wiper blades are worn or damaged or if streaking occurs.

i01077829

Windows - Clean

SMCS Code: 7310; 7340

Use commercially available window cleaning solutions in order to clean the windows. Clean the outside of the windows from the ground, unless handholds are available.

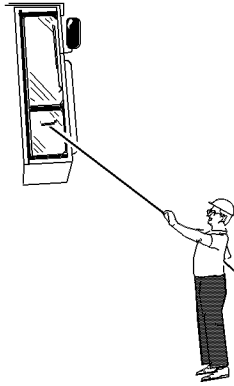

Illustration 313

g00566124

Typical example

Use a pole with a squeegee in order to reach the high areas of the window.

Cleaning Methods

Aircraft Windshield Cleaner

Apply the cleaner with a soft cloth. Rub the window with moderate pressure until all the dirt is removed. Allow the cleaner to dry. Wipe off the cleaner with a clean soft cloth.

Soap and Water

Use a clean sponge or a soft cloth. Wash the windows with a mild soap or with a mild detergent. Also use plenty of lukewarm water. Rinse the windows thoroughly. Dry the windows with a moist chamois or with a moist cellulose sponge.

Stubborn Dirt and Grease

Wash the windows with a good grade of naphtha, of isopropyl alcohol, or of Butyl Cellosolve. Then, wash the windows with soap and with water.