

740B EJ

Articulated Truck



Engine

Engine Model Tier 4 Interim/EU Stage IIIB	Cat® C15 ACERT™	
Gross Power – SAE J1995	365 kW	489 hp
Net Power – ISO 14396	361 kW	484 hp

Weights

Rated Payload	38 tonnes	42 tons
---------------	-----------	---------

Body Capacities

Heaped SAE 2:1	23.1 m ³	30.2 yd ³
----------------	---------------------	----------------------

New Features

Unique Cat® Ejector Body Features

C15 Engine with ACERT™ Technology meeting Tier 4 Interim/EU Stage IIIB engine emission regulations

Cat “on-the-go” Regeneration System

Controlled Throttle Shift (CTS) Transmission

Automatic Traction Control (ATC)

Passenger grab handle

Floor-mounted accelerator pedal

Park brake switch – guarded by raised dash moldings

Dash dimmer switch

Headliner with radio/CD mounting

Machine width position lamps

Electric hood switch mounted in-cab

External grab rail around cab roof

Improved fuse panel

Color Multi-Purpose Display (CMPD) incorporating the rearview camera screen and cycle counter

Machine Security System Tornado-ready (optional)

External roof-level work lights (optional)

Motorized mirrors (optional)

Contents

Engine with ACERT™ Technology.....	3
Transmission.....	4
Suspension and Automatic Traction Control (ATC).....	5
Operator Comfort.....	6
Ease of Operation.....	7
Durability and Reliability.....	8
Ejector Body.....	9
Product Link.....	10
Serviceability.....	11
Complete Customer Support.....	12
Safety.....	13
Sustainability.....	14
740B EJ Articulated Truck Specifications.....	15
740B EJ Standard Equipment.....	20
740B EJ Optional Equipment.....	20
Notes.....	21



The new Cat® 740B EJ with 38 tonnes (42 tons) rated payload offers proven reliability and durability, high productivity, superior operator comfort and lower operating costs.

The spacious two-person cab with forward facing passenger seat and off road oil/nitrogen front suspension cylinders keep the operator comfortable through out the working day.

The true “on-the-go” Automatic Traction Control (ATC) automatically modulates the correct level of Inter-Axle and Cross-Axle differential lock engagement which will improve cycle times and productivity. No operator interaction.

Strong, durable Cat ACERT™ engines with the Tier 4 Interim/EU Stage IIIB exhaust emission solution and electronically controlled smooth shifting transmissions deliver high productivity with low fuel consumption. There are significant changes/improvements to the engine/transmission software that result in smoother gear changes.

Engine with ACERT™ Technology

Innovative technologies optimize performance.

ACERT Technology

The Cat® C15 ACERT™ engine continues the evolutionary, incremental improvements that provide breakthrough engine technology built on systems and components developed by Caterpillar with proven reliability.

Cat Clean Emissions Module (CEM)

CEM is an exhaust aftertreatment package consisting of a diesel particulate filter, and control systems. The CEM reduces particulate emissions using passive and active regeneration during normal engine operation.

Cat NOx Reduction System (NRS)

The Cat NOx Reduction System (NRS) captures and cools a small quantity of exhaust gas, then routes it into the combustion chamber where it drives down combustion temperatures and reduces NOx emissions.

Fuel Delivery

Mechanically actuated Electronic Unit Injection (MEUI-C) multiple injection fuel delivery involves a high degree of precision. Precisely shaping the combustion cycle lowers combustion chamber temperatures, generating fewer emissions and optimizing fuel combustion. This translates into more work output for your fuel cost.

Diesel Particulate Filter Regeneration

Regeneration

Regeneration is the removal of soot from the Diesel Particulate Filter (DPF). The Aftertreatment Regeneration Device (ARD) is used to regenerate the DPF.

The DPF traps both particulates and ash, the ash is removed through a manual cleaning process.

Modes of Regeneration

When set to automatic, regeneration will occur without any interaction from the operator. The three modes of regeneration shown below allow the articulated truck to adapt to specific site conditions in the most efficient manner.

Automatic “On-the-go” regeneration is initiated when the engine control module determines conditions are acceptable. The articulated truck is not required to stop working.

Automatic: Low Idle regeneration is initiated when the machine is in a reduced operating mode for a predetermined period of time, and a number of conditions are met. The system is designed so that the operator can interrupt regeneration at any time.

Manual: A manual regeneration is initiated by pressing the regeneration switch for 5 seconds. The machine must be brought to a non-operating mode in order to perform a manual regeneration.



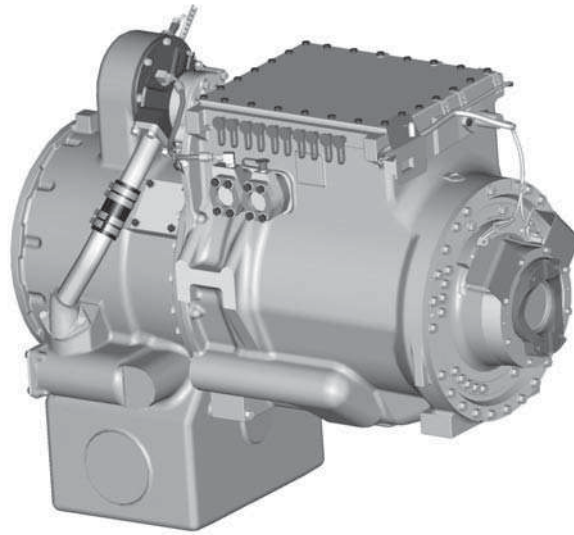

Transmission

Proven Reliability.

Electronic Transmission

The Cat® seven-speed forward, two speed reverse Electronic Clutch Pressure Controlled (ECPC) transmission features enhanced shift control logic with anti-hunt shift strategy for speed continuity, and to ensure constant shift times.

Min-max Governor Control

ECPC control is matched to the min-max governor control for precise smooth shifting.

Two Reverse Gears

The transmission arrangement provides a second reverse gear for improved performance when operating in longer rear hauling applications.

Smooth Transmission Gear Shifting

The 740B EJ features ECPC Shift Torque Management (STM), with improved Shift Control Logic (SCL) and Part Throttle Shifting (PTS). These features allow smoother shifting and greater acceleration on grades while torque is maintained through the shift changes. SCL also provides automatic shift selection that is more specific to the desired machine operation, and downshifts when needed for maximum acceleration when increased throttle is applied. PTS allows shifting at lower speeds during part throttle operation, resulting in improved part throttle fuel economy, quieter machine operation, and better maneuvering in reduced speed operating conditions.

Suspension and Automatic Traction Control (ATC)

Performance and Productivity.

Front Suspension

The three-point front suspension oscillates $\pm 6^\circ$ to provide a smooth ride, allowing the operator to travel at speed over rough terrain and softening impact loads on structures and components. Large bore, low pressure cylinders are purpose designed for tough applications and offer a soft, smooth ride.

Rear Suspension

Features a walking beam geometry with Caterpillar designed rear suspension mounts which provide a reliable and stable ride for excellent load retention.

Automatic Traction Control

Fully Automatic Traction Control (ATC). Inter-Axle-Differential lock (IAD) and Cross-Axle-Differential lock (XAD) feature oil immersed clutches that require no operator input. Operation is seamless and smooth, and it eliminates wheel slip for maximum traction.

Sensors monitor the machine and wheel speeds, enabling instant response in low traction conditions.

Fully automatic, independent IAD and XAD clutches are engaged on-the-go to optimize machine performance and control in all conditions. Clutches are automatically disengaged when ground conditions dictate, maximizing efficiency when steering or on uneven ground.

ATC eliminates wheel spin in soft under foot extreme ground conditions where little traction is available. It also reduces tire and driveline abuse eliminating lost efficiency caused by improper manual operation of the differential clutches.

Retardation Control

The Cat engine compression brake control lever is positioned on the right-hand side of the steer column.

Four modes of operation with three steps of retardation, provide an optimum match between operating conditions and retarding power.

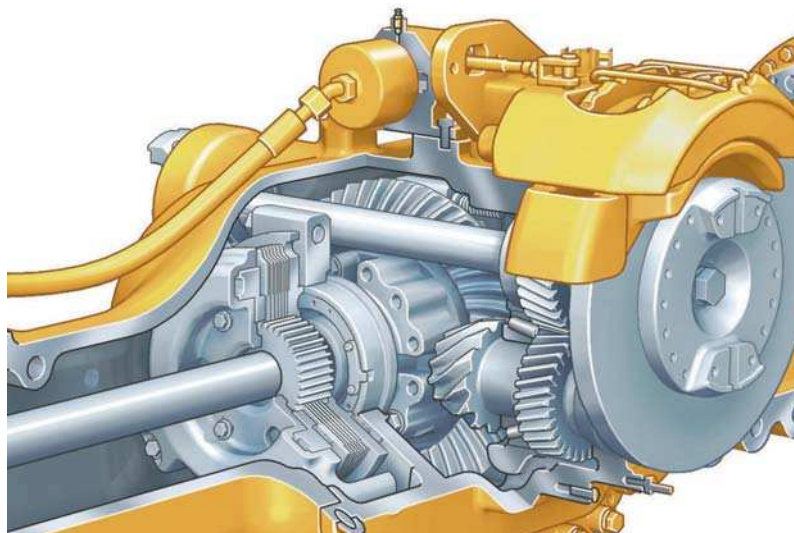



Operator Comfort

High productivity from a comfortable, confident operator.

Ride Comfort

The three-point front suspension with its oscillating axle and low-pressure ride struts, combined with the center-mounted cab, offers unrivaled levels of ride comfort for the operator in all driving conditions. The operator remains comfortable and productive throughout the day.

Spacious Two-Person Cab

The 740B EJ features a large two-person cab, offering comfortable working space for both the operator and trainer or trainee. The 735B, 740B and 740B EJ articulated trucks use the same spacious cab design.

Air Suspension Seat

The air suspension seat enhances operator comfort with a cushioned upper high back, adjustable damping with three settings, ride zone indicator and adjustable lumbar settings. It is fully adjustable to provide the optimal driving position.

Trainer Seat

Full-size passenger seat features a fully padded seat with a backrest and a wide, retractable seatbelt for a secure and comfortable ride. The passenger seat is positioned next to the operator seat, giving both the operator and passenger a clear view of the instrument panel, controls and the road.

Steering Column

A comfortable driving position is provided by a telescopic and tilt adjustable steering column.

Ease of Operation

Designed for ease of use – allows the operator to focus on production.

Ergonomic Layout

The controls and layout of the cab are designed to make it as easy to operate as your car. Quick, easy to read and simple to operate, the controls and gauges on the 740B EJ allow the operator to concentrate on production.

Dash

The integrated wrap-around dash puts all controls within easy reach of the operator. Featuring LED illuminated rocker switches for the dash dimmer, rear wash wiper, hazard warning, head lamp, work lamp, heated mirror (optional), diff-lock, secondary steer, heated seat (optional), machine security system (optional), A/C, cigar lighter, Color Multi-Purpose Display (CMPD) unit incorporating the messenger and rear view display. It provides an automotive feel with the industrial strength you would expect from Caterpillar.

Color Multi Purpose Display (CMPD)

A multi screen display unit showing various levels of machine warning categories, performance and condition pages, including: Performance, Settings, Totals, Service, Machine Status, Operator, and Rearview Camera.

Warning Categories

The monitoring system provides four warning categories.

The first warning category requires only operator awareness.

The second warning category requires a change to machine operation or performance of maintenance to the system.

The third warning category requires an immediate change of the machine operation.

The fourth category requires the operator to immediately stop the machine. The fourth category also requires the operator to immediately shut down the engine.

Viewing Area

The low sloping hood and placement of the cooling package behind the cab give the operator excellent all-around visibility. The large glass area and central operator position also provide excellent visibility.

Transmission and Ejector Levers

Finger tip controls allow easy operation and low effort. The ejector and transmission levers are positioned for easy comfortable operation, along with the control for top gear limit, transmission hold and neutral lock.





Durability and Reliability

High machine availability maximizes productivity and lowers costs.

Front Frame

The front frame design features a large box section and wide, stiff frame beams to handle torque loads. The divergent frame design decreases stress in the hitch area and optimizes suspension geometry. The frame design makes maximum use of robotic welding for increased durability.

Rear Frame

Twin-box construction minimizes stress concentrations and provides low weight with long service life.

Suspension

The three-point oscillating axle front suspension provides unparalleled ride quality. It also protects the truck from adverse road conditions by absorbing shock loads that would reach the frame.

Articulating/Oscillating Hitch

The articulating hitch provides the truck with steering articulation, and the oscillation ensures all-wheel ground contact in rough terrain.

Hitch Construction

Two-piece construction features a durable cast steel head bolted to a hard-wearing forged steel tube.

Fast Hoist Cycle Times

Fast body raise and lower times mean less time spent in the dump area.

Load-Carrying Capacity

The 740B EJ has a large target area to provide consistently high load-carrying capacity. Its diverging flow design gives clean load ejection, which maximizes production and avoids the waste of material carry-back.

Output Transfer Gear

Provides lubrication of all bearings and clutches using a distributed-pressure lubricated and filtered system.

Enclosed, Oil-Cooled Brakes

Multi-plate, oil-immersed brakes are fitted to both front and center axles. These brakes provide outstanding stopping capability, while maintaining maximum durability and low wear characteristics.

Parking Brake

Fitted to the center axle in an elevated position, spring applied and hydraulically released.

Ejector Body

Disperse loads on-the-go for faster cycles and lower spreading costs.

Ejector

The ejector body offers clean load ejection on-the-go and the capability to work in areas with restricted overhead clearance and soft underfoot conditions.

Versatility

The 740B EJ shares the versatility of the Standard 740B Series Articulated Truck, operating in the same conditions, but offering unique capabilities that stretch the operation envelope.

Spreading

The truck can eject and spread the material while moving, reducing additional spreading and dozing equipment. “On-the go” ejecting results in faster cycle times and reduced power train loads.

Stability

Ejecting the load without raising the body increases stability, allowing load dispersal on inclines, side slopes and in very soft underfoot conditions especially on landfill sites.

Overhead Clearance

The truck can eject in areas with reduced overhead clearance, such as around overhead lines or in tunneling and underground operations.

Carry-Back

The body design eliminates material sticking to the body, which increases productivity, improves fuel efficiency and lowers cost per ton.

Body

Reinforced body is made from thick high-yield, heat-treated Brinell hardened steel (Brinell 400 on the base and sides) that provides exceptional durability. Ejector top rails are made from high-strength alloy steel. For optimum durability and wear life, the ejector body is designed to work in applications where the material consists of rocks smaller than 152 mm (6 in) in diameter.

Blade

The ejector blade is made from high-strength steel and uses technology similar to that proven in Cat wheel tractor-scrapers.

Cylinder

A four-stage, high-speed, double-acting cylinder is specifically designed for horizontal mounting and smooth load ejection.





Product Link

A secure and user-friendly application.

Cat Product Link*

Cat Product Link allows remote monitoring of the Articulated Truck to improve overall fleet-management effectiveness. Product Link is deeply integrated into machine systems. Events and diagnostic codes, as well as hours, fuel, idle time and other detailed information are transmitted to a secure web based application, VisionLink™. VisionLink includes powerful tools to convey information to users and dealers, including mapping, working and idle time, fuel level and more.

* Product Link licensing not available in all areas. Please consult your Cat dealer for availability.

Key Points

- See your entire fleet at a glance
- Monitor fuel usage
- Set up site boundaries and security alerts
- Click through to your Cat dealer for service and parts
- Customize the alerts and displays that matter to you
- Compare working time versus idle time
- Reduce owning and operating costs
- Get the right information to the right people at the right time
- Vital Information Maintenance System (VIMS™) upgrades available

New Features

- Completely updated
- Robust new hardware
- Remarkably intuitive web-based interface
- Satellite and cellular coverage
- Open-system design for mixed-fleet use

Serviceability

More time on production.

Long Service Intervals

Long engine oil change and hydraulic oil change intervals lower maintenance costs and downtime. Wheel-bearing adjustment is completely eliminated.

Lube Points

Lube points are grouped at the rear of the front frame and the front of the rear frame. Universal joints are lubed for life, eliminating servicing. Autolube is optional.

Service Points

Engine and transmission dipstick and fill caps, air and fuel filters, and the fuel priming pump are all mounted on the left side of the engine under the electrically raised hood. Coolant level indicator and fill cap are outside the cab.

Radiator

The radiator package is located behind the cab, which provides protection from frontal impacts and offers easy access to the inlet and outlet sides of the radiator. The ATAAC radiator is located at the front of the truck.

Extended Life Coolant

Extends the change interval and improves component life by reducing aluminum corrosion.

Electrical Service Center

Located inside the cab, this service center provides a power port, diagnostic connector and Cat Data Link connector.

Cat Data Link Connector

The Cat Data Link connector provides a plug-in using a laptop computer with Electronic Technician (ET) software.

Service Access

The cab tilts to the side to provide easy access underneath, which simplifies access of the transmission, drive shafts and hydraulic pumps. Machine electrical and hydraulic interfaces are located on the right side of the cab, behind a removable cab body panel for easy access.

Truck Transport

The suspension system eliminates the need to lower the suspension when transporting the truck, reducing maintenance and downtime.





Complete Customer Support

Cat[®] dealer services help you operate longer with lower costs.

Selection

Make comparisons of the machines you are considering before you buy. Your Cat[®] dealer can help.

Purchase

Consider the resale value, compare productivity and day-to-day operating costs and fuel consumption.

Operation

For the best operating techniques to increase productivity and your profit, turn to your Cat dealer for the latest training literature and trained staff.

Maintenance

Repair option programs guarantee the cost of repairs up front. Diagnostic programs such as S-O-SSM and Technical Analysis help you avoid unscheduled repairs.

Replacement

Repair or rebuild? Your Cat dealer can help you evaluate the costs so you can make the right choice.

Product Support

Your local Cat dealership will be with you every step of the way with its unsurpassed worldwide parts support, trained technicians and customer support agreements.

cat.com

For more complete information on Cat products, dealer services and industry solutions, visit us on the Web at www.cat.com

Safety

Designed with safety as the first priority.

Product Safety

Caterpillar has been and continues to be proactive in developing machines that meet or exceed safety standards. Safety is an integral part of all machines and system designs.

Safety Features

- Cab integral ROPS (Roll Over Protection System) and FOPS (Falling Object Protection System)
- Rearview camera system provides a continuous panoramic rear view or when reverse gear is selected
- The secondary and parking brake functions are spring applied and hydraulic released
- Electro-hydraulic secondary steering system, automatically activates in forward/reverse or when stationary if low pressure is sensed. Can be manually selected for machine recovery purposes.
- External engine fuel cut off switch for easy access from outside of the machine
- External electrical system disconnect switch for easy access from outside of the machine
- Slip resistant surfaces – punched steel plate
- Hood raise and lower switch fitted at the LHS of dash
- 75 mm (3 in) wide retractable seat belts for operator and passenger/trainee
- Cab roof mounted spot lights
- Wide angled mirrors for excellent rear visibility
- Sweeping hood design for panoramic forward visibility
- Extensive hand rails
- Body raised alarm
- Heated motorized mirrors (optional)
- LED flashing beacon





Sustainability

Resourceful in every way.

The 740B EJ is designed to maximize efficiency and productivity while conserving natural resources.

Air Quality

The C15 ACERT engine incorporating the Cat Clean Emission Module (CEM) meets U.S. EPA Tier 4 Interim/EU Stage IIIB emissions requirements and designed to incorporate Tier 4 final/EU Stage IV emissions systems at future machine product introduction.

The C15 ACERT engine has the flexibility of running on either ultra-low-sulfur diesel (ULSD) fuel or bio-diesel blended with ULSD. All fuels must have no more than 15 ppm sulfur.

Re-cycle Waste

Caterpillar Design, Manufacture, Assemble and Test Site at Peterlee in England re-cycles 90% of all waste produced.

The 740B EJ is manufactured to be rebuilt and remanufactured to reduce waste and replacement costs.

The 740B EJ is an efficient, productive machine that is designed to conserve our natural resources for generations ahead.

740B EJ Articulated Truck Specifications

Engine

Engine Model	Cat® C15 ACERT™	
Gross Power – SAE J1995	365 kW	489 hp
Net Power – SAE J1349	354 kW	474 hp
Net Power – ISO 14396	361 kW	484 hp
Bore	137 mm	5.4 in
Stroke	171.5 mm	6.75 in
Displacement	15.2 L	926 in ³

- The power ratings apply at rated speed of 1,700 rpm when tested under the conditions for the specified standard.
- The net power advertised is the power available at the flywheel when the engine is equipped with alternator, air cleaner, muffler and fan at minimum speed.
- Net power when the fan is at maximum speed is 321 kW (435 hp) per the SAE reference conditions.
- The 740B EJ meets EPA Tier 4 Interim/ EU Stage IIIB emission specifications for the U.S. and Europe through 2013
- No engine derating required below 2438 m (8,000 ft).
- Peak engine torque gross (SAE J1995) 2510 N-m (1,850 lb-ft)
- Peak engine torque net (SAE J1349) 2466 N-m (1,819 lb-ft)
- Peak engine torque speed (1,200 rpm)

Weights

Rated Payload	38 tonnes	42 tons
---------------	-----------	---------

Body Capacities

Heaped SAE 2:1	23.1 m ³	30.2 yd ³
Struck	17.8 m ³	23.3 yd ³

Transmission

Forward 1	8.9 km/h	5.5 mph
Forward 2	12.1 km/h	7.5 mph
Forward 3	16.4 km/h	10.2 mph
Forward 4	22 km/h	13.7 mph
Forward 5	30 km/h	18.6 mph
Forward 6	40 km/h	25.1 mph
Forward 7	54.7 km/h	34 mph
Reverse 1	8.4 km/h	5.2 mph
Reverse 2	11.6 km/h	7.2 mph

Sound Levels

- | | |
|--------------|----------|
| Interior Cab | 79 dB(A) |
|--------------|----------|
- The operator sound exposure Leq (equivalent sound pressure level) measured according to the work cycle procedures specified in ANSI/SAE J1166 OCT 98 is 79 dB(A), for the cab offered by Caterpillar, when properly installed and maintained and tested with the doors and windows closed.
 - Hearing protection may be needed when operating with an open operator station and cab (when not properly maintained or doors/windows open) for extended periods or in noisy environments.

Operating Weights

Front Axle – Empty	21 395 kg	47,168 lb
Center Axle – Empty	8127 kg	17,917 lb
Rear Axle – Empty	7373 kg	16,255 lb
Total – Empty	36 895 kg	81,340 lb
Front Axle – Rated Load	1642 kg	3,620 lb
Center Axle – Rated Load	18 179 kg	40,078 lb
Rear Axle – Rated Load	18 179 kg	40,078 lb
Total – Rated Load	38 000 kg	83,776 lb
Front Axle – Loaded	23 027 kg	50,788 lb
Center Axle – Loaded	26 306 kg	57,995 lb
Rear Axle – Loaded	25 552 kg	56,333 lb
Total – Loaded	74 895 kg	165,115 lb

Body Plate Thickness

Front	6 mm	0.24 in
Side	6 mm	0.24 in
Base	10 mm	0.39 in

Service Refill Capacities

Fuel Tank	565 L	149.3 gal
Cooling System	80 L	21.1 gal
Hydraulic System	328 L	86.6 gal
Engine Crankcase	38 L	9.5 gal
Transmission	72 L	19 gal
Final Drives/ Differential	72 L	19 gal
Output Transfer Gear Box	18 L	4.8 gal

Ejector Cycle Times

Eject Time	14 Seconds
Retract Time	24 Seconds

Standards

Brakes	ISO 3450 – 1996
Cab/FOPS	ISO 3449 Level II – 2005
Cab/ROPS	ISO 3471 – 2008
Steering	ISO 5010 – 2007

740B EJ Articulated Truck Specifications

Dimensions

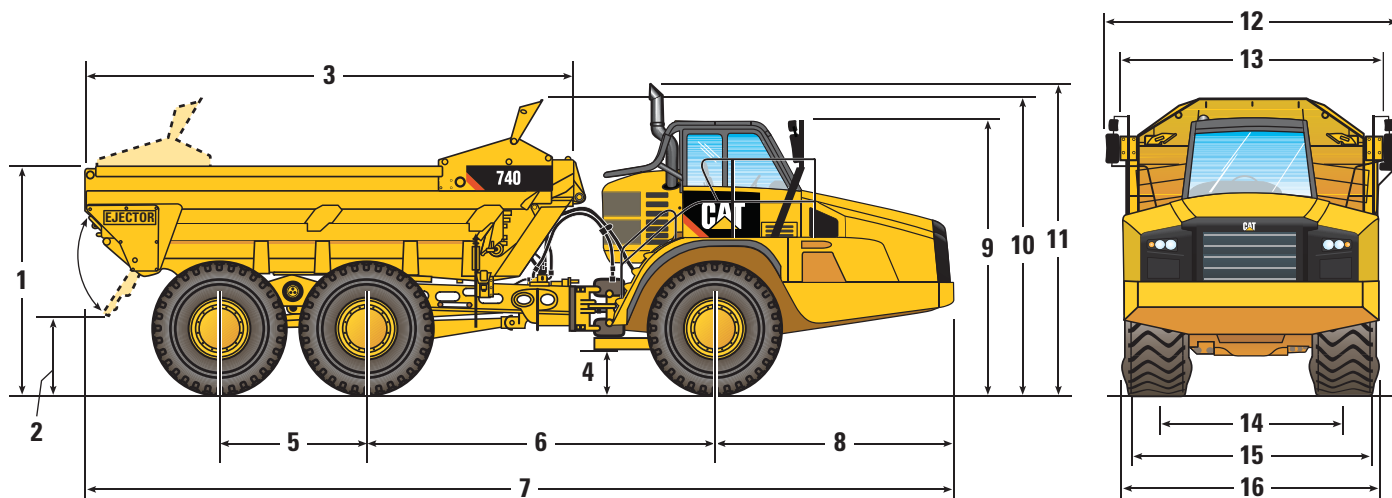

	mm	ft		mm	ft
1	3067	10.0	9	3745	12.2
2	1098	3.6	10*	3984	13.1
3	6730	22.1	11**	4039	13.3
4	577	1.8	12	4163	13.7
5	1966	6.4	13	3512	11.5
6	4596	15.0	14	2687	8.8
7	11 698	38.4	15	3430	11.2
8	3330	10.9	16***	3527	11.6

*Hinged spill plate for transportation.

**Exhaust stack can be removed for transportation.

***Max-unladen over tire bulge.

Turning Circle

Dimensions are for machines equipped with 29.5R25 tires.

Turning dimensions

Steer angle – left/right	45°	
SAE turning radius	8640 mm	340.2 in
Clearance radius	9090 mm	357.9 in
Inside radius	4470 mm	176.0 in
Aisle width	5930 mm	233.5 in

Steering

Lock to Lock

4.6 seconds @ 60 rpm

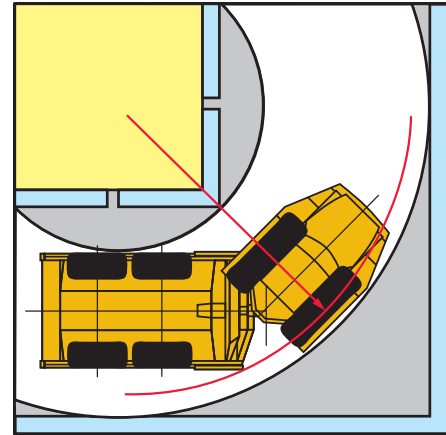

Optimal Loader/Truck Pass Matching

Hydraulic Excavators	390D	374D	349D/E
Loader Capacity (Tonnes) – 50 min hr	954-1193	750-1100	665-805
Loader Capacity (Tons) – 50 min hr	1,049-1,314	825-1,210	735-885
Passes	3-4	4-5	5-6

Wheel Loaders	988H	980H/K	972H/K	966H/K
Loader Capacity (Tonnes) – 50 min hr	565-790	590-650	490-565	400-535
Loader Capacity (Tons) – 50 min hr	625-870	650-717	540-625	440-590
Passes	3-4	4-5	5	5-6

An optimum system match gives you a major productivity advantage. The 740B EJ is an excellent match for the Cat 349D/E, 374D and 390D Hydraulic Excavators; and 966H/K, 972H/K, 980H/K and 988H Wheel Loaders. This results in increased production and lower system costs per unit of volume moved.

740B EJ Articulated Truck Specifications

Gradeability/Speed/Rimpull

To determine performance, read from Gross Weight down to % Total Resistance. Total Resistance equals actual % grade plus 1% for each 10 kg/metric ton (20 lb/ton) of Rolling Resistance. From this point, read horizontally to the curve with the highest attainable speed range. Then, go down to Maximum Speed. Usable Rimpull depends on traction available.

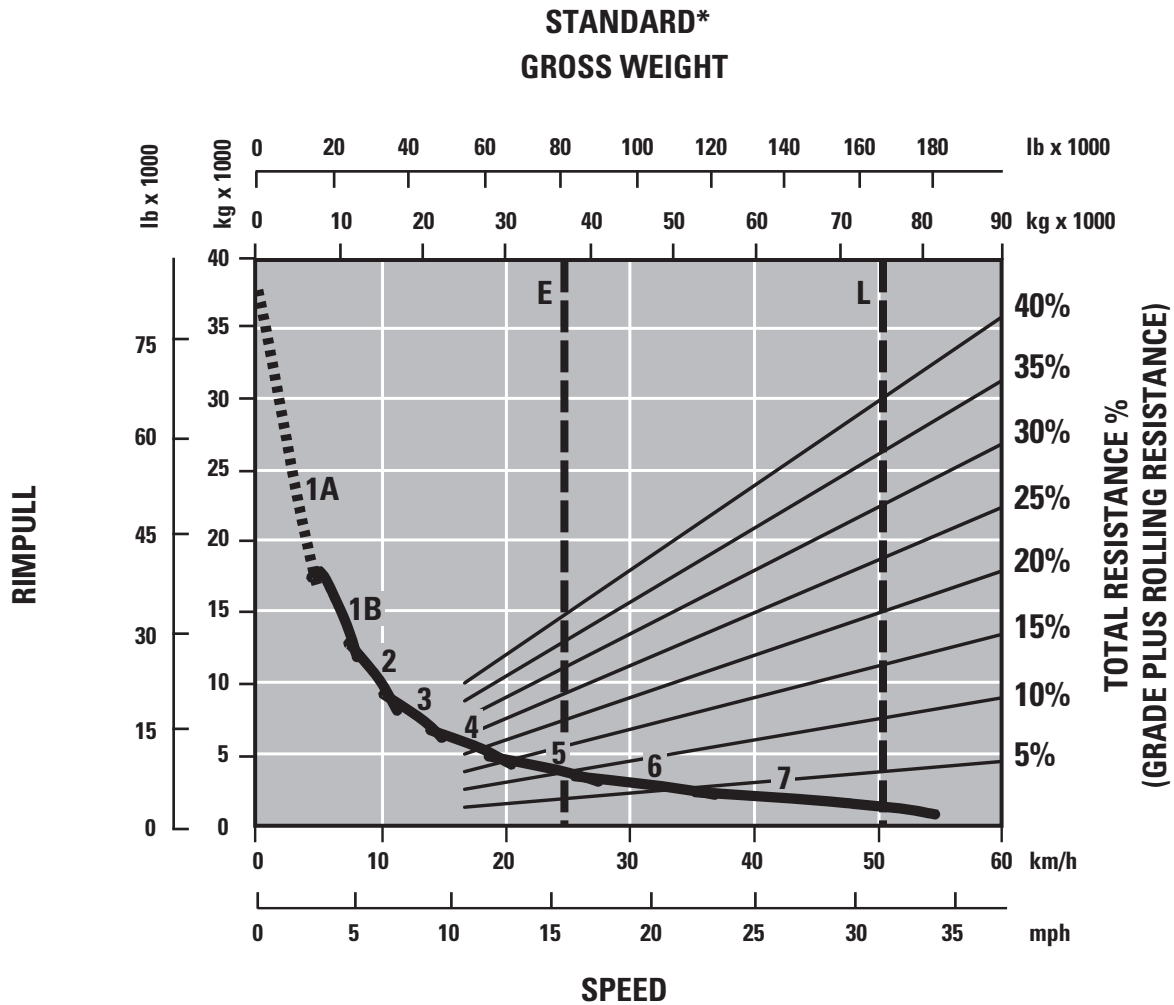

- 1A – 1st Gear (Converter Drive)
- 1B – 1st Gear (Direct Drive)
- 2 – 2nd Gear
- 3 – 3rd Gear
- 4 – 4th Gear
- 5 – 5th Gear
- 6 – 6th Gear
- 7 – 7th Gear

- E – Empty 36 895 kg (81,400 lb)
- L – Loaded 74 895 kg (165,115 lb)
- * at sea level

Retarding Performance

To determine performance, read from Gross Weight down to % Effective Grade. Effective Grade equals actual % favorable grade plus 1% for each 10 kg/metric ton (20 lb/ton) of Rolling Resistance. From this point, read horizontally to the curve with the highest attainable speed range. Then, go down to Maximum Speed. Retarding effect on these curves represents full application of the retarder.

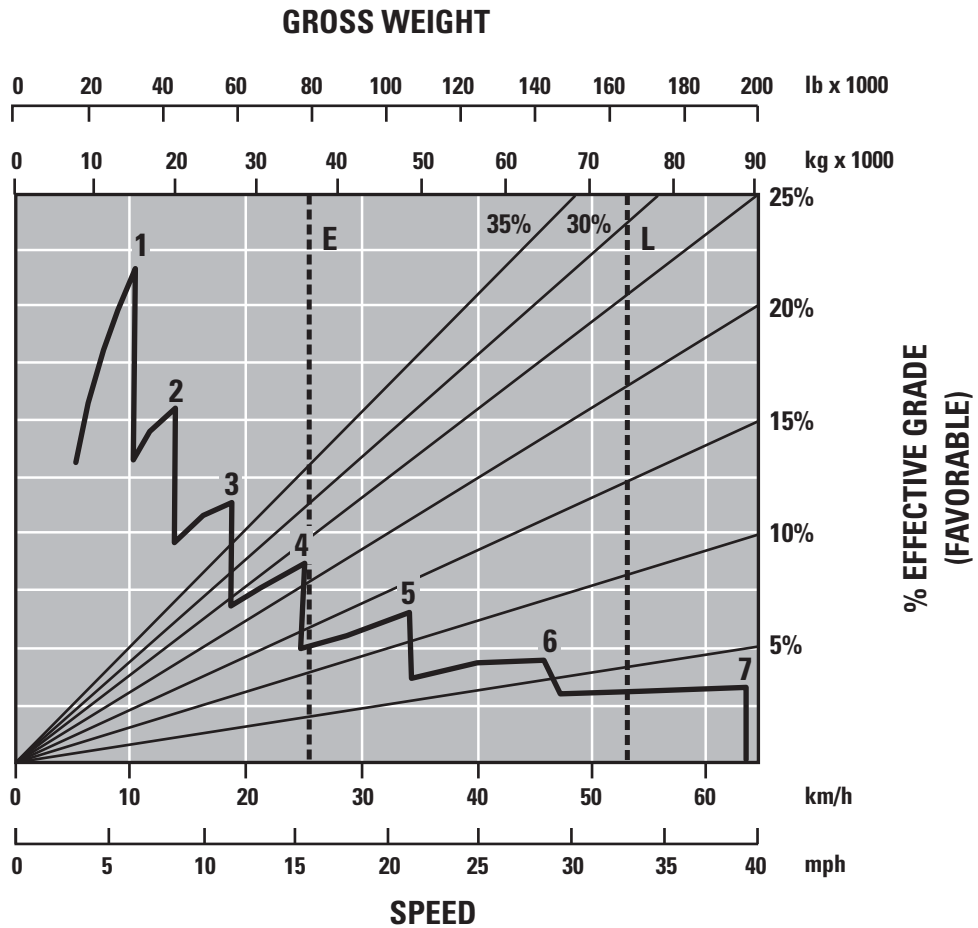

- 1 – 1st Gear
- 2 – 2nd Gear
- 3 – 3rd Gear
- 4 – 4th Gear
- 5 – 5th Gear
- 6 – 6th Gear
- 7 – 7th Gear

- E – Empty 36 895 kg (81,400 lb)
- L – Loaded 74 895 kg (165,115 lb)

740B EJ Standard Equipment

Standard equipment may vary. Consult your Cat dealer for details.

Air conditioning with R134A refrigerant	Heater and defroster with four-speed fan	– LCD warnings/indicators: Gear, Alert, Speed, Soot, DPF Regeneration, Engine hours, Primary Steer, 2nd Steer, Machine Security (MSS), Retarder
Air vents, adjustable	Hinged spill guard for ease of transportation	– Meters: service hour meter, speedometer, tachometer
Automatic Traction Control (ATC)	Horn, electric	Seat, fully adjustable, air suspension
Auto shift seven-speed forward and two-speed reverse transmission	Lights: cab interior, front, side, rear, two reversing/working lights, two stop/tail lights, side width marker, front and rear direction indicators	Seat, padded passenger
Back up alarm	Mirrors, main and auxiliary, left and right	Secondary steering – electronic
Body, adapted for exhaust heat	Mud flaps, wheel arch and body mounted, with transportation tie backs	S·O·S SM sampling valves
Body, including Ejector cylinder and blade with integrated spill guard	Oil-cooled brakes, enclosed	Starting receptacle, electric, remote
Cat® C15 engine with ACERT™ Technology	Operator and passenger grab hand rails	Storage – two cup holders, flask receptacle, under seat storage, door pocket, behind seat storage, coat hook
Cat Clean Emission Module (CEM) an exhaust aftertreatment package	Product Link where applicable	Sun visor
Color Multi-Purpose Display (CMPD) Incorporating the Cycle Counter and Rearview Camera Screen	Retarder, Engine compression brake	Tailgate, hydraulic automatic
CD/Radio, heavy duty ready	ROPS/FOPS cab, with full instrumentation, including:	Three-axle, six wheel drive
Differentials, standard with automatic clutched cross-axle and inter-axle differential locks for all axles	– Instrument cluster display module	Tilt and telescopic steering wheel
Electrical system: 24 volt, 5A 24- to 12-volt converter	– Indicator lamps: left turn, secondary steering, primary steering loss, front and rear brake temp (735B/740B and 740B Ejector only), brake oil pressure, action lamp, transmission fault, park brake, charging system status, differential lock, body not in float, right turn, high beam, transmission hold, machine filter warning, retarder, retarder up shift warning	Tires, 29.5R25, radial
Electro hydraulic hoist control	– Gauges: engine oil pressure, engine coolant temperature, torque converter oil temperature, fuel level, fuel tank level gauge	Towing eyes, front and rear tow pin
Ether starting aid		Two seat belts, retractable
Glass windows, laminated and tinted, front		Vandalism protection: lockable caps for fuel tank and hydraulic oil tank
Glass windows, toughened and tinted, sides and rear		Windows opening side, tinted
Guards: rear window, radiator, crankcase and axle		Windshield wiper and washer, two speed, intermittent (front)
Headlights, four		Windshield wiper and washer, two speed, (rear)

740B EJ Optional Equipment

Optional equipment may vary. Consult your Cat dealer for details.

Autolube installation for automatic greasing of bearings	Engine Block Heater	Heated rearview motorized mirrors
Cab roof mounted headlamps	Exhaust heated body	Heated seats
CD/Radio, heavy duty	Extensions, fender	Product Link PL 321, PL 522 and PL 523 (where available)
Cold Weather Coolant (–51° C/–59.8° F)	Fast fuel fill	Machine Security System (MSS)
Cold weather start attachment	Flashing LED Beacon	
	Fuel Additive – Anti-Waxing	

740B EJ Articulated Truck

For more complete information on Cat products, dealer services, and industry solutions, visit us on the web at www.cat.com

© 2012 Caterpillar Inc.
All rights reserved

Materials and specifications are subject to change without notice. Featured machines in photos may include additional equipment. See your Cat dealer for available options.

CAT, CATERPILLAR, SAFETY.CAT.COM, their respective logos, "Caterpillar Yellow" and the "Power Edge" trade dress, as well as corporate and product identity used herein, are trademarks of Caterpillar and may not be used without permission.

AEHQ6134-01 (11-2012)
Replaces AEHQ6134

