

8750

Dragline

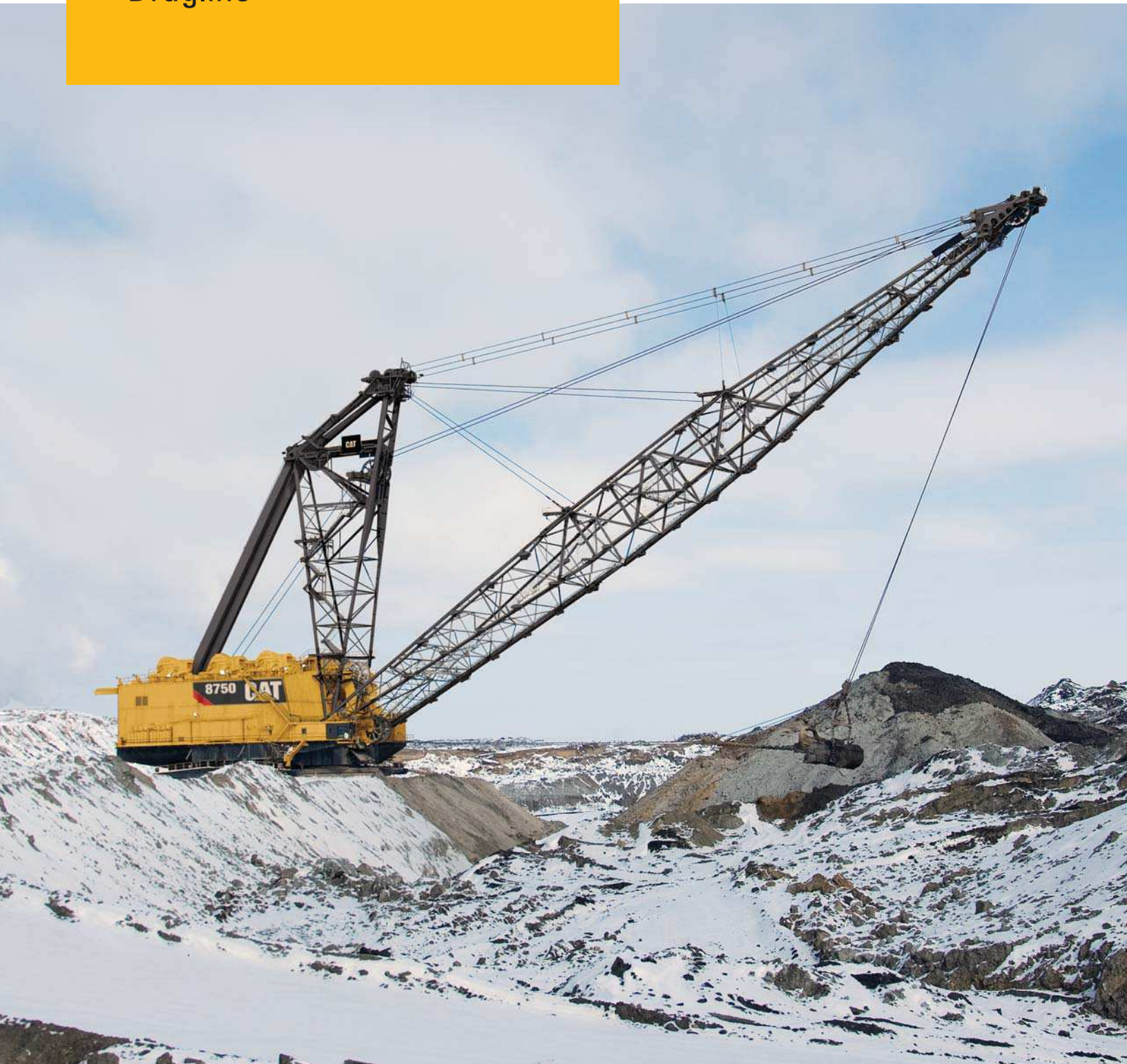

Dimensions/Working Ranges

Bucket Capabilities	76-116 m ³	100-152 yd ³
Boom Lengths	109.7-132.5 m	360-435 ft
Rated Suspended Load	226,800-344,736 kg	500,000-760,000 lb
Approximate Working Weight	5.8-7.5 million kg	13.1-15.9 million lb

Electrical

IGBT-AFE Inverter Cabinets	4 or 5 Water-Cooled	
Hoist Motors	6 to 8 × 1230 kW	6 to 8 × 1,650 hp
Drag Motors	6 to 8 × 1230 kW	6 to 8 × 1,650 hp
Swing Motors	7 to 10 × 932 kW	7 to 10 × 1,250 hp
Walking Motors	4 × 932 kW	4 × 1,250 hp

Experience and Expertise

Leveraging over a century of experience supporting customers through industry leadership and unmatched dragline expertise, Caterpillar is proud to continue this legacy. Whether you look to us to service your existing draglines, to relocate and refurbish a pre-owned dragline, to design innovative dragline technologies, or to work collaboratively with you to determine the optimal dragline configuration for your operation, we will apply the institutional knowledge and expertise, developed over decades, to ensure your success.

Contents

- AC Electrics.....4
- Operator’s Cab..... 6
- Mechanical Systems.....8
- Major Structures.....10
- Cat® MineStar™ System and Technology Solutions12
- Dragline Model Selection.....14
- Aftermarket Solutions15
- Safety16
- Serviceability17
- Customer Support.....18
- Operator Training20
- Sustainability21
- Specifications.....22
- Notes.....26





Offering the highest levels of overburden removal productivity at the lowest total cost per tonne (ton), the 8750 is the flagship model of the Cat dragline product line. The first dragline of any kind to be successfully equipped with AC IGBT drive systems, we developed this superior technology for the sole purpose of making your workday more productive, predictable, and most importantly, safe.

AC Electrics

More reliable and efficient electrics



Tried and True AC IGBT Electric Drive System, Now on Mining Equipment's Largest Platform

You will experience greater machine uptime, lower operating costs, and faster cycle times with our AC dragline designs that leverage institutional knowledge built on 30 years of experience commissioning more than 200 AC equipped machines worldwide.

Benefits over DC Machines

• Superior availability

- Routinely demonstrated electrical availabilities of greater than 95%.
- Extended mean time between failures, and reduced mean time to repair.

• Better reliability

- Less vulnerable to input voltage variation.
- No filters, robust design, independent of mine network.
- Full power available with voltage $\pm 10\%$.
- Continues to operate with reduced power with voltage -10% to -30% .

• Greater efficiency

- Provide 10% energy savings over the life of the dragline.
- AC drives have an overall efficiency of 92% vs. DC machines of 88%.

• Less maintenance

- No regular maintenance is required on IGBT power control modules
- Motor maintenance is reduced to greasing and replacing bearings around 30,000 hours.
- Reduced maintenance resulting from lack of motor and generator brushes requiring change-out. This translates to increased machine electrical availability and reduced maintenance labor costs.

• Reduced inventory

- IGBT modules are interchangeable between Active Front Ends (AFEs), inverters, motions and machines.
- Optional interchangeability: All AC motors for drag, hoist, swing, and propel motions are the same.
- No brush inventory to maintain.



AC Technology

Optimizing your AC system performance and reliability, we've incorporated the latest in AC technology and utilized the most durable components available.

Motion Regulator Control (MRC)

- Sturdy, mine-grade cabinet mounted on a self supporting steel structure encloses all power and control electronics.
- AFE, rather than rectifiers, convert AC to DC power.
- Fuseless IGBT modules in AFEs and inverter.
- Onboard maintenance computer is easy to troubleshoot, quickly identifies faults, and provides instructions to resolve issues.
- Major control and power electrics are derived from the transportation sector, allowing for high temperature ratings, shock and vibration ruggedness, and longevity of component availability.
- IP 54 enclosure – liquid cooled, heat transferred out of machinery house.
- Cabinets allow optimized cable routing.
- Cable internals organized to allow efficient access to internal components.



Harmonics

- Staggered Active Front Ends (AFE) naturally cancel harmonics without filters, which makes the dragline very robust and independent of mine network configuration.
- Provides better Total Harmonic Distortion (THD) than required by IEEE 519.



High Voltage Switchgear

- Rated at 24 kV.
- SF6 gas-insulated switchgear.
- Provides programmable protection and control for Auxiliary Power Transformer (APT) and Drive Power Transformer (DPT).
- Arc resistant (Arc flash).
- Internal and key interlocking provides for safe operation.



AC Main Motion Drive Motors

- Simple, AC squirrel-cage induction motors power swing, hoist, drag and propel motions.
- Built in speed sensor that is replaceable without removal of motor from service.



Operator's Cab

Maximize your performance with enhanced safety and comfort features

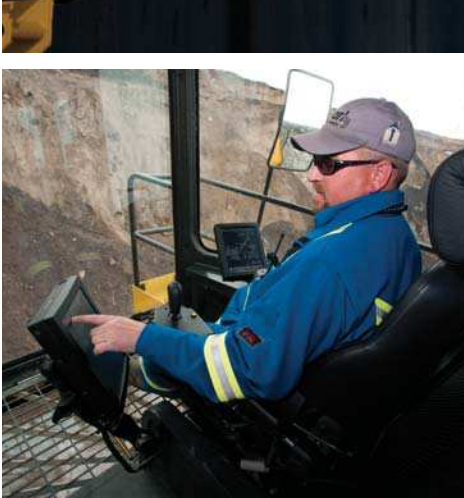



Comfort Infused, State-of-the-art Operator's Cab and Station

Providing more comfort, added safety, and greater reliability, our newly designed state-of-the-art operator's cab will help you produce more. The product of a multi-year collaboration with mining companies from across the globe, our Design Engineers, armed with insights into the aspects most desired by you, have designed what we believe to be the most comfortable and productivity-enhancing operator's cab in the industry.

• Improved operator performance

- Reduced cognitive fatigue and enhanced productivity via the intuitive and visually aesthetic display screens.
- Effortless operation and improved control response resulting from new Hall Effect joysticks (patent pending), with custom-designed ergonomic handles and "finger touch control" spring tension.

• Enhanced safety

- Rear ingress/egress door with no step floor prevents trip hazard, particularly in cases of emergency where rapid exit from the cab is necessary.
- Superior visibility with full operator-to-boom point line of sight.
- Maximum operator situational awareness via external camera system with direct feed to overhead monitors in cab.
- Enhanced safety during operator training with additional emergency stop button within reach of trainer seat.



Mechanical Systems

Maximizing your uptime with durable and dependable mechanical systems



Keeping You Up and Running with Meticulously Engineered and Globally Proven Mechanical Systems

Reliability you've come to depend on, our dragline mechanical systems have proven field history in mine sites across the globe, from the extreme heat of Australia to the frigid temperatures of Canada.

Swing Machinery

- Highly reliable swing planetary transmission and output pinion.
- Interchangeable parts across all swing drives.
- Potential for machine to operate with removal of one swing unit (typical maintenance).
- Cooler/filtration unit plumbed to each planetary gearcase. Controlled and monitored via dragline Programmable Logic Controller (PLC).

Hoist/Drag Machinery

- Parallel shaft gearcases, with eccentric bearing cartridges for optimal gear alignment.
- Gearing, bearings, drums, etc are interchangeable between hoist and drag motions.
- Splash lubricated gearcases with optional filtration available.
- Leak proof inspection hatches for inspection of all gear mesh.
- Drums mounted on self aligning, anti-friction bearings.
- Motors coupled to input pinions with grid couplings to reduce impact loads.



Propel Machinery

- Heavy duty eccentric cam, driven by bull gear and parallel shaft gearbox.
- Eccentric bushing continuously monitored via RTD's. PLC will alarm and shut down machine if permissible temperatures are exceeded.
- Each side independently driven, but electrically synchronized, monitored and adjustable via dragline PLC.
- Shoe incorporates ball swivel mounting to accommodate variable ground conditions.
- Ability to propel machine up and down 10% grade and transverse across 5% grade.

Major Structures

Bolstering your life-of-mine investment with robust and durable dragline structures

Rugged Structures Designed and Fabricated to Withstand Your Extreme Mining Conditions

To extend service life and ultimately reduce your maintenance cost, all major dragline structures are designed for durability and dependability. Extended performance in the harsh mining conditions you face daily is accomplished through selection of high-strength steels, and rugged castings, joined and thermally stress-relieved to create a reliable shell capable of the most productive surface extraction machine in the industry.



- Boom and Tri-structures are manufactured using cold-weather, impact-resistant, high-strength steel with select welds of full penetration, profiled and ground type.
- All structural welds undergo visual inspection, with critical welds also receiving MT, UT or X-ray inspection.
- For reduced susceptibility to cracking, large furnaces are used to stress-relieve entire weldments.
- Simplifying field inspections, interiors of finished structures are painted white.



Base Frame Assembly

- Grid-Radial design to optimize load and access.
- Forged integral center pintle.
- Stress relieved "T-section" roller path sub-weldment.
- Thick bottom plate, with abrasion resistant steel wear plates and anti-skid cleats.

Roller Circle, Rails and Racks (Gear Segment)

- Large diameter machined crowned rollers.
- Third rail eliminates flanged rollers allowing addition of more rollers extending service life significantly.
- Bias cut rail ends for smooth roller transition.
- Forged/fabricated rack segments, stress relieved weldment, quenched and tempered teeth.



Revolving Frame Assembly

- Deep, rectangular frame structure, running full length of assembly.
- Integrated thick rail pad circumferential diaphragm sub-weldment, UT tested, and ground.
- Thick integrated plates for support of main machinery.
- Penetrations reinforced with through thickness plates as determined per FEA.

Fairlead Assembly

- Over-under fairlead provides constant rope contact with sheaves.
- Sheaves interchangeable with boom and tri-structure.
- Shimless fairlead adjustment system for lower swivel.
- Rubber composite “donut” between swivels to dampen dynamics.

Tri-structure Assembly

- Tri-structure design reduces front end weight and enables optimization with boom configurations, increasing allowable load and reach.
- Simplified wide flange beam construction, with high impact strength steel.
- Less maintenance points compared to A-frame/Mast assembly.
- Crack detection system for back legs and tri-structure head assembly, monitored by a warning indicator in the PLC.

Boom Assembly

- Rectangular, deep cross section geometry, constructed of high strength wide flange beams.
- Pre-stretched galvanized main support ropes with equalizers. Kevlar intermediate boom support ropes .
- Drop down stabilizer rope to mitigate dynamics in main support ropes.
- Pressurized apex lacings, monitored through PLC.
- Boom point sheave assembly to equalize rope.

Bucket Assembly

- Bucket capacity and style application dependent.
- Final capacity takes into account ground mass per cubic meter, soil characteristics, abrasion, and digging style.
- Bucket capabilities range from 76-116 m³ (100-152 yd³).
- Rigging configuration is twin dump.
- Custom wear packages designed to suit a variety of soil conditions.
- Three different bucket styles available, HPS, Conventional, and Fabricated.

Dynavane Assembly

- Modular Dynavane assemblies decrease roof weight, easier to maintain and install.





Cat[®] MineStar[™] System and Technology Solutions

Evolving your mine for greater safety and productivity

Helping You Enhance Safety and Productivity through Technology

Aimed at enhancing the productivity and profitability of your dragline, we currently offer a combination of Cat MineStar System offerings and Cat dragline technology solutions.

Cat MineStar System

Helping you achieve your goals for enhanced mine site safety, improved efficiency, reduced operating costs, and greater profitability, the Cat MineStar System provides the most comprehensive suite of mining technology products in the industry. It consists of a number of configurable capability sets – Fleet, Terrain, Detect, Health, and Command – that allow you to scale the system to your mine site needs. Cat MineStar System helps you manage everything from material tracking to sophisticated real-time fleet management, machine health systems, autonomous equipment, and more.

The Cat 8750 dragline is currently able to utilize two of the Cat MineStar System capability sets:

- **Fleet**

- Fleet provides real-time machine tracking, assignment and productivity management, providing a comprehensive overview of all your asset operations from anywhere in the world.

- **Terrain**

- Terrain enables high-precision management of drilling, dragline, grading and loading operations through the use of guidance technology. It increases machine productivity and provides you real-time feedback for improved efficiency.

The remaining Cat MineStar System capability sets are currently under development for the Cat dragline product line.

Dragline Technology Solutions

Enhancement of productivity and efficiency is afforded through Cat dragline technology solutions. This facilitates real-time machine tracking, assignment and productivity monitoring, reducing mean time to repair (MTTR), a full package of diagnostic equipment is also available.

- **AccessDirect**

- Enables factory experts to join the local maintenance team.
- Prepares maintenance personnel to arrive on site ready to fix rather than analyze the problem.
- Reduces MTTR and daily maintenance efforts.
- Enhances local and remote diagnostic capabilities.

- **Description**

- Electrical interface system that facilitates remote access to machine's on board computer via internet.
- Permits monitoring, adjustment, resetting, and modification of electrical parameters.
- Arrives with software for PLC, software for drives resident, and one server per fleet.
- Features high-speed data transfer.





Dragline Model Selection

Maximizing your return on investment and optimizing your dragline performance

Dragline Model Recommendations Grounded in Analysis and Collaboration

Protecting your investment and ensuring that you achieve your cost per ton targets, we have on-staff Application Engineers and a new dragline optimization process to help determine the dragline configuration optimally suited for your application.

Application Engineering

- Specialize in analyzing mine environments and applying findings to recommendations for new draglines configured specifically to meet your productivity targets.
- Analyze existing dragline performance and apply findings to recommendations for upgrade solutions.
- Work collaboratively with you to consider factors, such as your digging environment, mine life, mine plan, and annual production targets, among others, to determine the proper dragline configuration for your mine site.

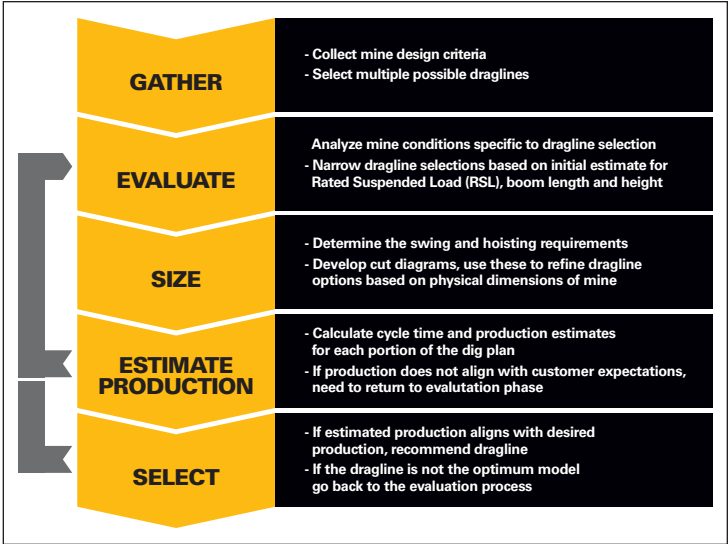

New Dragline Optimization Process

Aftermarket Solutions

Improving your productivity and reliability over the life of your machine

Productivity and Reliability Enhancements for Existing Cat Draglines

A dragline is a life-of-mine asset. To ensure that your investment provides the highest level of performance, productivity, and financial return over time, we offer a stable of top-quality, globally-available aftermarket solutions.

Mechanical Upgrades

- Provide full mechanical component upgrades for existing draglines.
- In-house and third party Finite Element Analysis expertise employed to ensure that replacement parts outperform the original components.
- Solutions include:
 - Major dragline structure repair/replacement for improved reliability and productivity enhancement.
 - Boom modifications to optimize Rated Suspended Load (RSL), operating radius, digging depth, and dumping height.
 - Re-engineered components for improved performance.



Electrical Upgrades

- Owners of legacy draglines can reap the benefits of the latest technology, reducing operating cost, and improving machine productivity and reliability.
- Tailored solutions that address your specific needs, whether you own an AC or DC powered dragline.
- Allows electrical system to work in harmony with on-board mechanical systems.
- Solutions include:
 - Drive system upgrades for enhanced performance (AC and DC machines).
 - Programmable Logic Controller (PLC) and Human Machine Interface (HMI) upgrades for enhanced safety and availability.
 - Production Monitoring System for optimized productivity.
 - On-board troubleshooting and remote diagnostics for improved reliability.

Dragline Relocation and Field Assembly

- Fundamental elements of the Cat dragline portfolio.
- Offer turn-key solution of OEM dragline parts, dragline service expertise, and local resources.
- Unmatched institutional knowledge of current and legacy dragline models ensures informed upgrade recommendations, leading to more productive and reliable operations following relocation.

Component Rebuilds

- Highest quality OE component rebuild services for both legacy draglines and current models in use today.

Safety

Designed with your safety as our top priority



Sharing your commitment to safety, and driven by our commitment to Zero Harm, we work tirelessly to design the safest machines possible to protect your most important asset; your employees.

Some examples of the safety-enhancing features of Cat draglines include the following.

Operator's Cab

- Industry leading visibility.
- Additional visibility provided by five optimally mounted cameras and operator cab mounted overhead displays.
- Dual egress doors; rear door and level floor provide unimpeded stretcher to operator access.
- Unique three seat design accommodates operator, trainer, and maintenance person.

- Observer's seat, positioned behind operator, provides maintenance personnel with the operator's view while allowing him or her to monitor operator actions.
- Separate operator and trainer emergency stop buttons.

Structures/Surfaces

- Sturdy handrail mounting clamps prevent vibration induced weld cracks.
- Non-skid material on roof and shoe walkway surfaces prevent falls.
- Serrated bar grating stairs, platforms and walkways facilitate safe movement around the machine.

Electrical Equipment

- Emergency stop system is hardwired dual string with safety relay.
- All operator interface controls are 24 volt.

- Arc Flash evaluation available.
- Single point of motion disable for mechanical maintenance of machine.
- Key interlocking prevents access to incoming High Voltage connection areas.
- Stored energy warning signs installed at appropriate locations reduce injuries.

Emergency Lighting

- Improves personnel safety by lighting the machine during power outages.

Operator Training

- Provides a safe and controlled learning environment to help produce a more skilled and safer operator.

Serviceability

Designed to get you back to work fast

Lowering your operating costs through reduced incidents of unplanned maintenance, longer intervals between scheduled service, and easier serviceability are of supreme importance to us.

Promoting safer and easier maintenance activities, Cat draglines have improved access to most major service points.

Base Access

- Easy accessibility to base via manholes inside and outside of roller circle path.

Revolving Frame Access

- Ability to move from section to section throughout all compartment spaces.

Swing Platform

- Raised platforms for swing, brake, blower, and electrical termination maintenance.

Machinery House Accessibility

- Substantial walkways/work areas around deck-mounted machinery and electrical equipment.

Hoist/Drag Access

- Ready accessibility to hoist and drag drums via stairs, walkways, and platforms.

Hoist/Drag Rope Clamps

- Clamps eliminate need to lift heavy components to attach rope to drum.

Dirt Chute Access

- Cleats and lanyard attachment points within dirt chute.
- Long lasting poly wear blocks are easy to remove and handle.



Overhead Crane

- Overhead cranes provide coverage to most major components.
- Safe access via walkways along the entire length of the machinery house.

Fairlead Internal Access

- Ladder rung access to lower and upper access points.

Fairlead Sheave Maintenance

- External access ladders and walkways allow for ready maintenance.
- Upper sheave removal system available.

Tri-Structure Access

- Walkways provide access to major service points.

Boom Access

- Improved access to suspension rope connections.
- Walkway system allows inspection on upper and lower lacing-chord connections.

Remote Bulk Lube Tank Fill

- Easily accessible maintenance point for lube servicing.

Lights

- Robust exterior flood lighting brackets allow for changing flood lights from walkways and platforms.
- Machinery house internal highbay lighting is accessible from boxes with quick opening hatches on top of roof.
- Boom and Tri-structure ballasts are accessible in the machinery house.



Customer Support

Stay up and running with service and support from our unmatched global network

Providing You a Unified Team Unlike Any Other in the Mining Industry

While the Caterpillar acquisition of Bucyrus is complete, we are still in the process of integrating the two companies. However, you can rest assured that both your Cat and Bucyrus products will continue to be supported and that there will be no disruption in the service you have come to expect from both organizations.

We are committed to business as usual — with sales, parts fulfillment, technical support, and all other customer services continuing uninterrupted. For the time being, Caterpillar Global Mining will operate from two distinct distribution channels:

- Legacy Bucyrus products, including our draglines, will continue factory direct with support from former Bucyrus employees that are now part of Caterpillar's Global Mining Division.
- Traditional Cat products will continue through Cat dealers with support from Caterpillar's Global Mining Division.



We Will Transition Products to the Cat Dealer Network

With the goal of providing you with one face and the distribution approach that positions you best for success, we will leverage the strength of the Cat dealer network. All products will eventually be sold and serviced by Cat dealers; however, the transition will occur in phases until complete.

We Will Create an Unparalleled Source for Support

The expertise you have come to depend on will continue in the Caterpillar organization, whether through a Cat dealer or from Caterpillar – combining the best of both organizations to create one unparalleled source for support.

Until the Transition Is Complete...

To ensure you have the support necessary to meet your production requirements, experienced and knowledgeable Caterpillar Service Engineers are available throughout the world.

Services offered include the following:

- Technical Service
- Non destructive UT testing
- Conditional analysis
- Suspension pendant inspections
- Alignment audits
- OEM supported technical consulting and troubleshooting

Maintenance and Repair Contracts

- 30+ years of experience
- Contracts tailored to each customer
- Parts planning and machine maintenance services
- Maximize value, while minimizing risk
- High degrees of customization and flexibility
- Inventory management support





Operator Training

Maximize your investment

Aimed at advancing a novice operator to expert levels in a rapid timeframe, our combination of on-site and computer-based training provides all the tools your staff will need.

To help maximize your investment in a Cat dragline, we provide on-site operator training assessments, on-site electrical and mechanical maintenance training, and a variety of computer-based training options.

Customized Training

- On-site and/or classroom training for dragline operators and mine operation supervisors.
- Aimed at developing internal training competency for your operation.
- Designed in module form to target key production issues specific to your operation.
- Trainers have years of experience with hands-on and classroom training, offering the necessary skills to implement changes on all aspects of operation, machine management, and maintenance.
- Utilizes cutting-edge technologies to improve knowledge retention, increase training efficiency, and create a safer learning environment via machine simulation.

Computer-Based Training (CBT) Modules

- Provide a cost-effective way to train employees, improve safety, and optimize machine performance.
- Offer convenient 24/7 access to training on a variety of topics ranging from safety and operation to mechanical and electrical repairs.
- Highly visual and interactive, the CBTs are short online courses on technical subjects, designed by training specialists.

Sustainability

Higher standards for a better tomorrow



Meeting the needs of today without compromising the needs of tomorrow is the goal for all Cat machinery. The commitment to helping you operate safely and sustainably is affirmed in the production of the 8750 dragline.

Cat Dragline Sustainability

• Power consumption

- Consumes less power, produces less heat and sound, and emits fewer greenhouse gasses than other methods of overburden removal.
- Energy savings, accompanied by higher productivity with AC IGBT electrics.

• Greenhouse gas emissions

- Fully electric machine with minimal sight emissions.

8750 Dragline Specifications

Weights – 22.9 m (75 ft) Base*

Boom Length @ 39°	109.7 m	360 ft
Net Weight, domestic, approximate with bucket	5 502 075 kg	12,130,000 lb
Working Weight, approximate with bucket	5 955 668 kg	13,130,000 lb
Ballast Weight, approximate	453 592 kg	1,000,000 lb
Boom Length @ 39°	117.3 m	385 ft
Net Weight, domestic, approximate with bucket	5 497 540 kg	12,120,000 lb
Working Weight, approximate with bucket	6 078 138 kg	13,400,000 lb
Ballast Weight, approximate	580 598 kg	1,280,000 lb
Boom Length @ 39°	124.9 m	410 ft
Net Weight, domestic, approximate with bucket	5 535 188 kg	12,203,000 lb
Working Weight, approximate with bucket	6 182 464 kg	13,630,000 lb
Ballast Weight, approximate	647 276 kg	1,427,000 lb

* Net weight, ballast weight, working weight kPa (psi) bearing pressure will vary with boom length, angle, and rated suspended load. Shipping weight subject to $\pm 5\%$ variance.

Electrical – 22.9 m (75 ft) Base

IGBT-AFE Inverter Cabinets	4 Water-Cooled*	
Hoist Motors	6 to 8 × 1230 kW	6 to 8 × 1,650 hp
Drag Motors	6 to 8 × 1230 kW	6 to 8 × 1,650 hp
Swing Motors	7 or 8 × 932 kW	7 or 8 × 1,250 hp
Walking Motors	4 × 932 kW	4 × 1,250 hp

* Motor combinations and IGBT-AFE Inverter Cabinets vary with boom length, angle, and rated suspension load.

Base – 22.9 m (75 ft) Base

Outside Diameter	22.9 m	75 ft
Bearing Area	410.5 m ²	4,418 ft ²
Bearing Pressure	137.9- 147.5 kPa	20.00- 21.40 psi
Circle Rail Diameter	16.8 m	55 ft
Rollers (average diameter)	35.6 cm	14 in
Swing Gear (pitch diameter)	13.87 m	45 ft 6 in

Walking Mounting – 22.9 m (75 ft) Base

Shoe Width and Length	4.3 m × 21.3 m	14 ft × 70 ft
Combined Bearing Area	182.1 m ²	1,960 ft ²
Bearing Pressure (@ 80% of working weight)	256.5- 268.9 kPa	37.20- 39.00 psi
Overall Width Over Shoes	32.3 m	106 ft
Length of Step (approximate)	2.13 m	7 ft

Dimensions – 22.9 m (75 ft) Base

All dimensions are approximate.

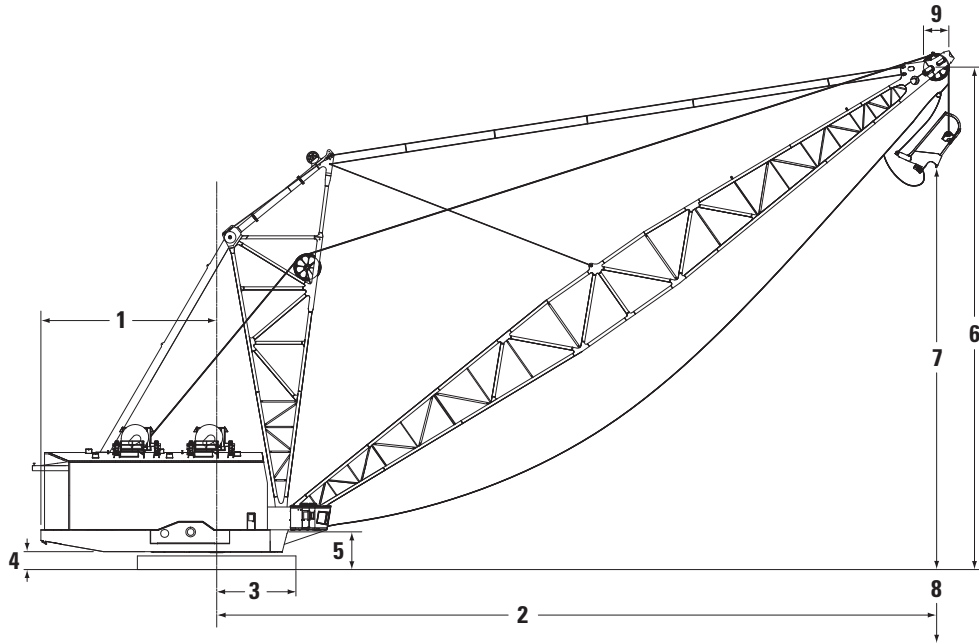

① Clearance Radius	27.9 m	91 ft 8 in
③ Boom Foot Radius	7.3 m	24 ft
④ Clearance Height	4.1 m	13 ft 4 in
⑤ Boom Foot Height	5.1 m	16 ft 10 in
⑨ Point Sheave Pitch Diameter	353.1 cm	139 in

Boom Length	Boom Angle	② Operating Radius		Rated Suspension Load		⑥ Boom Point Height		⑦ Dumping Height		⑧ Digging Depth		DRAG Drum Diameter		DRAG Rope Diameter		HOIST Drum Diameter		HOIST Rope Diameter				
		m	ft	kg	lb	m	ft	m	ft	m	ft	cm	in	cm	in	cm	in	cm	in			
109.7	360	39	94.5	310	394 840	650,000	74.2	243.5	52.1	171	54.8	180	317.5	125	2	11.76	4.63	317.5	125	2	11.76	4.63
109.7	360	35	99.1	325	294 800	650,000	68.07	223.3	46.3	152	63.4	208	317.5	125	2	11.76	4.63	317.5	125	2	11.76	4.63
117.3	385	39	100.2	329	278 964	615,000	78.9	259.1	57.3	188	55.1	181	317.5	125	2	11.76	4.63	317.5	125	2	11.76	4.63
117.3	385	35	105.1	345	278 964	615,000	72.4	237.6	50.5	166	61.8	203	317.5	125	2	11.76	4.63	317.5	125	2	11.76	4.63
117.3	385	32	108.5	356	263 088	580,000	67.3	220.8	46.3	152	69.1	227	317.5	125	2	11.43	4.50	317.5	125	2	11.43	4.50
124.9	410	39	106.1	348	249 480	550,000	83.7	274.8	62.7	206	52.7	173	317.5	125	2	11.43	4.50	317.5	125	2	11.43	4.50
124.9	410	35	111.5	366	242 676	535,000	76.8	252.0	56.7	186	64.9	213	317.5	125	2	10.79	4.25	317.5	125	2	10.79	4.25
124.9	410	32	114.9	377	226 800	500,000	71.3	234.1	51.2	168	70.4	231	317.5	125	2	10.79	4.25	317.5	125	2	10.79	4.25

8750 Dragline Specifications

Weights – 25.6 m (84 ft) Base*

Boom Length @ 39°	109.7 m	360 ft
Net Weight, domestic, approximate with bucket	6 597 500 kg	14,545,000 lb
Working Weight, approximate with bucket	6 876 006 kg	15,159,000 lb
Ballast Weight, approximate	278 505 kg	614,000 lb
Boom Length @ 39°	117.3 m	385 ft
Net Weight, domestic, approximate with bucket	6 705 000 kg	14,782,000 lb
Working Weight, approximate with bucket	7 125 480 kg	15,709,000 lb
Ballast Weight, approximate	420 480 kg	927,000 lb
Boom Length @ 39°	124.9 m	410 ft
Net Weight, domestic, approximate with bucket	6 709 992 kg	14,793,000 lb
Working Weight, approximate with bucket	7 223 005 kg	15,924,000 lb
Ballast Weight, approximate	513 013 kg	1,131,000 lb
Boom Length @ 39°	132.5 m	435 ft
Net Weight, domestic, approximate with bucket	6 672 341 kg	14,710,000 lb
Working Weight, approximate with bucket	7 202 140 kg	15,878,000 lb
Ballast Weight, approximate	529 796 kg	1,168,000 lb

* Net weight, ballast weight, working weight kPa (psi) bearing pressure will vary with boom length, angle, and rated suspended load. Shipping weight subject to $\pm 5\%$ variance.

Electrical – 25.6 m (84 ft) Base

IGBT-AFE Inverter Cabinets	4 or 5 Water-Cooled*	
Hoist Motors	6 to 8 × 1230 kW	6 to 8 × 1,650 hp
Drag Motors	6 to 8 × 1230 kW	6 to 8 × 1,650 hp
Swing Motors	8 or 10 × 932 kW	8 or 10 × 1,250 hp
Walking Motors	4 × 932 kW	4 × 1,250 hp

* Motor combinations and IGBT-AFE Inverter Cabinets vary with boom length, angle, and rated suspension load.

Base – 25.6 m (84 ft) Base

Outside Diameter	25.6 m	84 ft
Bearing Area	514.8 m ²	5,542 ft ²
Bearing Pressure	131.0- 140.6 kPa	19.00- 20.39 psi
Circle Rail Diameter	16.8 m	55 ft
Rollers (average diameter)	40.6 cm	16 in
Swing Gear (pitch diameter)	13.87 m	45 ft 6 in

Walking Mounting – 25.6 m (84 ft) Base

Shoe Width and Length	4.9 m × 24.4 m	16 ft × 80 ft
Combined Bearing Area	237.8 m ²	2,560 ft ²
Bearing Pressure (@ 80% of working weight)	226.8- 243.5 kPa	32.90- 35.32 psi
Overall Width Over Shoes	37.08 m	121 ft 8 in
Length of Step (approximate)	2.28 m	7 ft 6 in

Dimensions – 25.6 m (84 ft) Base

All dimensions are approximate.

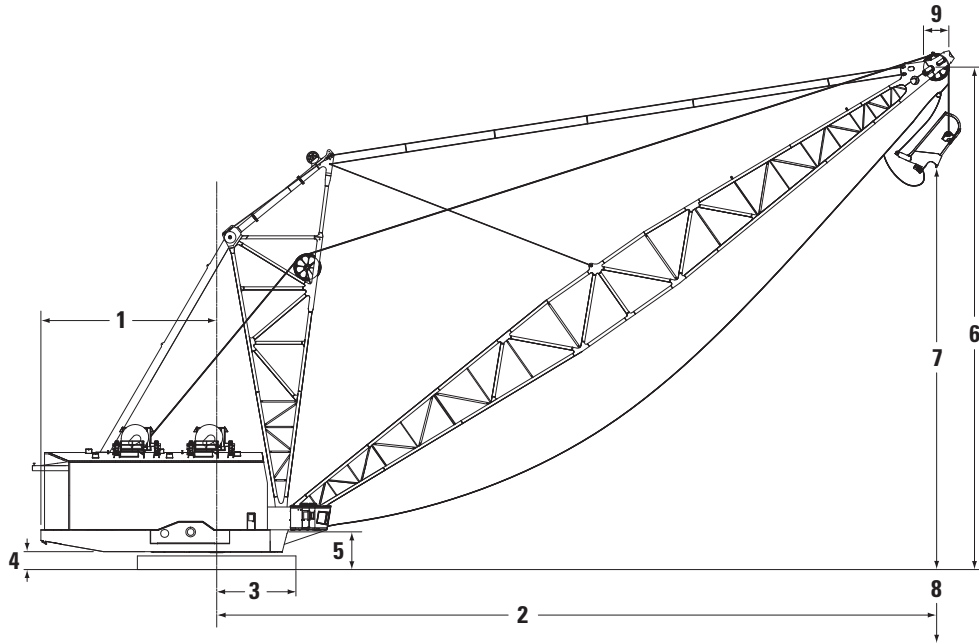

① Clearance Radius	29.26 m	96 ft
③ Boom Foot Radius	7.3 m	24 ft
④ Clearance Height	4.69 m	15 ft 5 in
⑤ Boom Foot Height	6.55 m	21 ft 6 in
⑨ Point Sheave Pitch Diameter	381 cm	150 in

Boom Length	Boom Angle	② Operating Radius	Rated Suspension Load		⑥ Boom Point Height		⑦ Dumping Height		⑧ Digging Depth		DRAG		HOIST									
					m	ft	m	ft	m	ft	m	ft	cm	in	Drum Diameter	Number	Rope Diameter	Drum Diameter	Number	Rope Diameter		
m	ft	m	ft	kg	lb	m	ft	m	ft	m	ft	cm	in	cm	in	cm	in	cm	in	cm	in	
109.7	360	39	94.5	310.0	344 736	760,000	75.6	248.0	50.2	165	66.7	219	330.2	130	2	13.03	5.13	330.2	130	2	13.03	5.13
109.7	360	35	99.1	325.1	344 736	760,000	69.5	228.0	44.5	146	72.5	238	330.2	130	2	13.03	5.13	330.2	130	2	13.03	5.13
109.7	360	32	102.2	335.5	322 056	710,000	64.7	212.3	40.2	132	79.8	262	330.2	130	2	12.70	5.00	330.2	130	2	12.70	5.00
117.3	385	39	100.4	329.5	344 736	760,000	80.4	263.8	55.1	181	61.8	203	330.2	130	2	13.03	5.13	330.2	130	2	13.03	5.13
117.3	385	35	105.3	345.6	344 736	760,000	73.9	242.3	48.7	160	68.2	224	330.2	130	2	13.03	5.13	330.2	130	2	13.03	5.13
117.3	385	32	109.0	356.7	283 500	625,000	68.7	225.5	46.0	151	74.1	243	330.2	130	2	11.76	4.63	330.2	130	2	11.76	4.63
124.9	410	39	106.3	348.9	306 180	675,000	85.2	279.5	61.5	202	58.5	192	330.2	130	2	12.06	4.75	330.2	130	2	12.06	4.75
124.9	410	35	111.5	366.1	317 520	700,000	78.2	256.8	54.5	179	65.5	215	330.2	130	2	12.70	5.00	330.2	130	2	12.70	5.00
124.9	410	32	115.2	377.9	272 160	600,000	72.8	238.9	50.6	166	78.6	258	330.2	130	2	11.76	4.63	330.2	130	2	11.76	4.63
132.5	435	39	112.3	368.3	263 088	580,000	90.0	295.2	67.9	223	61.2	201	330.2	130	2	11.43	4.50	330.2	130	2	11.43	4.50
132.5	435	35	117.8	386.6	254 016	560,000	82.6	271.0	60.3	198	72.2	237	330.2	130	2	11.43	4.50	330.2	130	2	11.43	4.50
132.5	435	32	121.6	399.2	240 404	530,000	76.8	252.0	55.4	182	76.2	250	330.2	130	2	11.43	4.50	330.2	130	2	11.43	4.50

8750 Dragline

For more complete information on Cat products, dealer services, and industry solutions, visit us on the web at www.cat.com

© 2012 Caterpillar Inc.
All rights reserved

Materials and specifications are subject to change without notice. Featured machines in photos may include additional equipment. See your Cat dealer for available options.

CAT, CATERPILLAR, SAFETY.CAT.COM, their respective logos, "Caterpillar Yellow" and the "Power Edge" trade dress, as well as corporate and product identity used herein, are trademarks of Caterpillar and may not be used without permission.

AEHQ6889 (09-2012)

