

# 906/908

## Compact Wheel Loaders



	906	908
Engine	Cat® 3044C	Cat® 3044C
Net Power	51 kW/68 hp	57 kW/76 hp
Operating Weight	4960 kg/10,912 lb	6040 kg/13,288 lb
Nominal Bucket Capacity	0.8 m³/1.0 yd³	1.0 m³/1.3 yd³

## 906/908 Compact Wheel Loaders

*Caterpillar designed and built to deliver exceptional performance and versatility, ease of operation, serviceability and customer support.*

---

### **Ease of Operation**

Operator comfort and simplified operation are designed into every aspect of the cab. With the VersaLink™ loader linkage and contoured hood, these machines offer unmatched visibility to the ground, enabling the operator to easily see the work being done. Ergonomically designed joystick and low effort pilot hydraulics reduce fatigue and increase comfort. Three cab options and two canopy options are available. **pg. 4**

---

### **Power Train**

Cat Compact Wheel Loaders use a Caterpillar power train for reliable, long life. The two-speed closed loop hydrostatic transmission delivers smooth power from full rimpull to runout. Precise inching control and smooth acceleration and deceleration minimizes operator fatigue. **pg. 4**

---

### **VersaLink™ Loader Linkage**

Loader linkage gives the Compact Wheel Loaders unsurpassed versatility and performance. The single piece boom-style lift arm design offers exceptional strength, rigidity and visibility. **pg. 5**

### ***Built for tough work***

*Cat® Compact Wheel Loaders are built to the same high standards as larger Cat® wheel loaders. These machines deliver Cat reliability, durability and efficient operation, even in the toughest working conditions.*

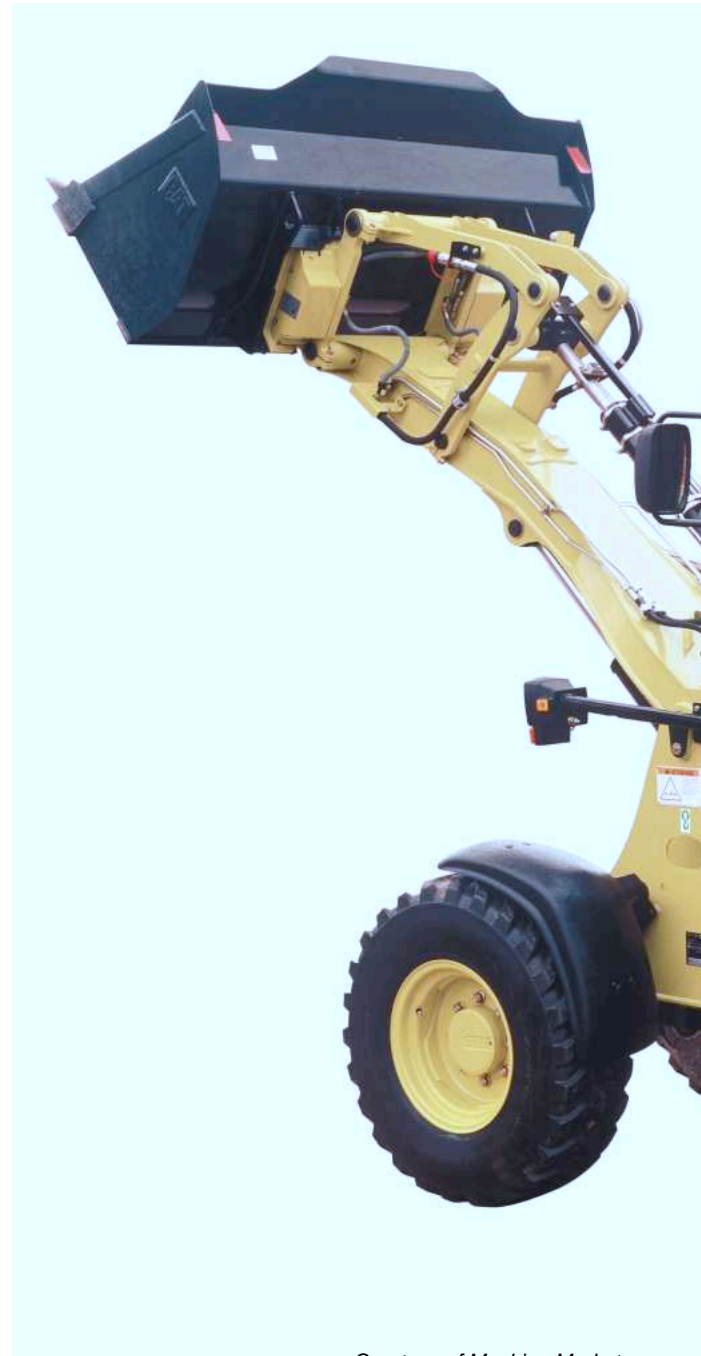



---

### Serviceability

Designed for quick and easy serviceability. Tilt-up engine enclosure and side service doors give exceptional access to major components. Hinged hydraulic oil cooler provides easy access for cleaning. Vertically mounted, Caterpillar spin-on filters are easy to reach for fast maintenance. S•O•S<sup>SM</sup> oil analysis ports for engine oil and hydraulic fluid, and ten hydraulic test ports are standard. Ecological drains are also available. **pg. 5**

---

### Work Tools

A broad range of Caterpillar Work Tools have been developed specifically for the Cat Compact Wheel Loaders to deliver exceptional performance and versatility. The integrated QuickLock hydraulic coupler allows the operator to quickly change from one work tool to another from inside the cab. **pg. 6**

---

### Reliability and Durability

Quality and reliability are built into every aspect of these machines. The same standards and quality components used in larger Cat machines are applied to the compact wheel loader line-up. These machines are all you expect from Caterpillar. **pg. 7**

---

### Customer Support

Caterpillar dealers offer unmatched customer support, excellent warranty programs, and fast parts availability, resulting in maximum uptime and minimum repair costs. Equipment maintenance services help optimize machine performance and reliability. Services include:

- Customer Support Agreements
- S•O•S<sup>SM</sup> oil analysis
- Maintenance contracts
- Scheduled technical inspections

Equipment management services help optimize profits. Services include:

- Machine and work tool selection
- Rental and leasing
- Purchasing and financing
- Owning and operating cost management

**pg. 7**



## Operator Station

*Ergonomically designed, world class cab offers unmatched comfort and ease of operation.*

**Excellent Viewing** in all directions is made possible with large, floor length windows, a compact dash, a contoured hood and the narrow VersaLink™ loader linkage.

**Low effort** pilot hydraulics and an ergonomically designed joystick with adjustable wrist rest maximizes operator comfort and minimizes fatigue. The molded-in Forward/Neutral/Reverse switch is simple to use.

**Spacious cab** offers plenty of storage space and is equipped with many convenience features:

- Fully adjustable suspension seat
- Suspended pedals and flat floor
- Ground level door releases
- Three-speed fan with eleven vents
- Front and rear wet wipers
- Cup holder and coat hook
- Auxiliary power sockets
- Lockable toolbox

**Easy to read dash** features backlit LED display and gauges within close view, including fuel level and hydraulic oil temperature. Sealed switches provide years of dependable service.

- 1 Standard Joystick with Proportional Auxiliary Hydraulic Control lever
- 2 Proportional Auxiliary Hydraulic Control mounted in joystick (optional)

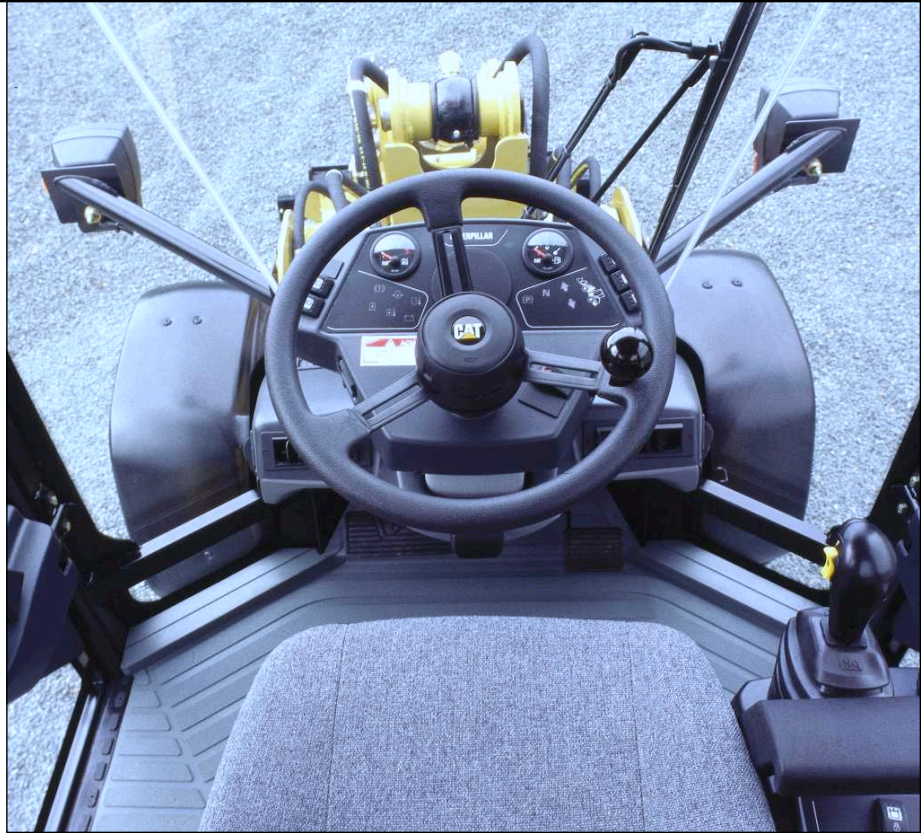

## Power Train

*Caterpillar® hystat power train delivers aggressive performance and easy operation.*

**Two-speed** closed-loop hydrostatic transmission delivers smooth shifting transition from full rimpull to runout. Precise inching control and smooth acceleration and deceleration minimizes operator fatigue.

**Rear axle** oscillates  $\pm 11$  degrees, giving the machine superior control, stability and traction in all applications, especially grading work.

**Limited slip** front differential provides excellent traction in a wide variety of working conditions.

**Unique brake reservoir** is self-replenishing for maintenance free service.



## VersaLink Loader Linkage and QuickLock Hydraulic Coupler

*Linkage design offers unparalleled versatility and superior performance.*

**Narrow Design** of the VersaLink Loader Linkage offers optimum visibility to each side of the QuickLock hydraulic coupler and work tool. This provides operators with an excellent view of the work area, including loading and dumping targets.

**Parallel lift** capability allows precise pallet handling, eliminating the need to adjust level while raising the forks. Operators can concentrate on load placement rather than load leveling.

**Long reach** lets the operator place loads more easily, while protecting the tires and front frame.

**Optimized linkage** design and powerful hydraulics result in excellent breakout force for buckets and high lift force with forks. Fast, controllable hydraulics provide short cycle times.

**Large contact area** of the QuickLock hydraulic coupler absorbs impact loads. Wedges with check valves keep work tools secure and rattle free.



## Serviceability

*Quick access and superior design features make the Compact Wheel Loader easy to service.*

**Ground Level** access is unmatched due to the high opening tilt-up engine enclosure and side service doors. All major components and service points can be easily accessed from the ground.

- Vertically mounted, spin-on hydraulic oil filter, fuel filter with water separator and engine oil filter
- Heavy duty braided wiring harness protects the electrical system
- Radiator fin design is less susceptible to plugging
- Hinged hydraulic oil cooler for ease of cleaning
- Hydraulic oil sight gauge and vented hydraulic system
- Air cleaner service indicator is easy to use and reliable

**S•O•S<sup>SM</sup> valves** are standard for easy oil sampling to help protect the engine and power train.

**Caterpillar extended life coolant** is standard, offering lower service intervals and reduced maintenance costs.

**Centralized lube points** for major components.

**2000-hour** hydraulic oil service interval under normal working conditions.

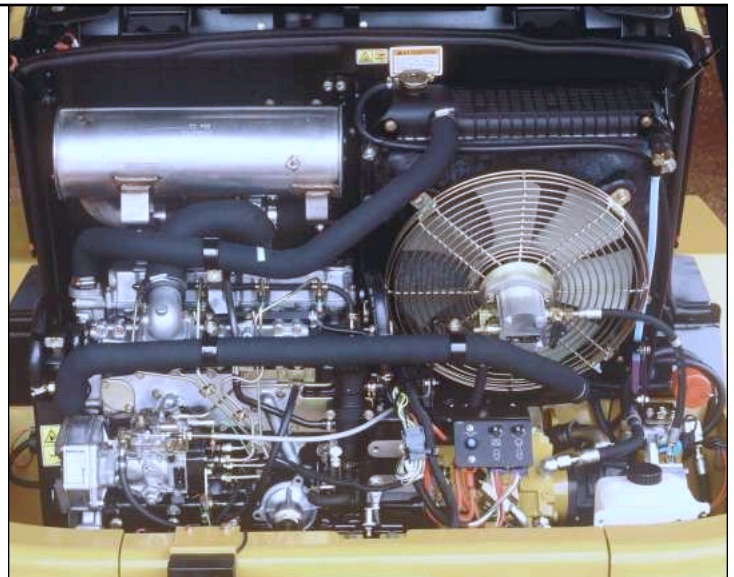

# Work Tools

*Increase your productivity by performing a variety of jobs with one machine.*

## Work Tools

Caterpillar designed work tools extend the versatility of the Cat® Compact Wheel Loaders. Built for performance and durability, a full range of work tools deliver high productivity, long service life and excellent return on investment.

- General Purpose Bucket
- Multi Purpose Bucket
- Light Material Bucket
- Side Dump Bucket
- Stone Sieve Bucket
- High Dump Bucket
- Material Handling Grapple Bucket
- Pallet Forks
- Angle Broom
- Pickup Sweeper

## QuickLock Hydraulic Coupler

The operator can make fast, easy work tool changes from inside the cab. Solid connections are assured every time with the QuickLock hydraulic coupler.

- Opposing wedge design
- Constant hydraulic pressure compensates for wear
- Check valves maintain tight engagement
- Rugged design has large contact area to absorb loads and minimize stress





## Durability and Reliability

*High quality components and assembly techniques ensure optimum protection and productivity.*

**Paint finish.** Cat Compact Wheel Loaders undergo an extensive 24-stage 'E-coat' painting process. Zinc based electroplated undercoat and polyurethane topcoat provides unmatched corrosion resistant properties. Paint color can be customized to meet customer requirements.

**Wiring.** Electrical connectors are sealed to lock out dust and moisture. Harnesses are braided for protection. Wires are color coded for easy diagnosis and repair.

**Cat Hoses.** Cat XT3 high-pressure hydraulic hose is exceptionally strong and flexible for system reliability and long life in the most demanding conditions.



## Customer Support

*Complete services provided by the world's largest dealer network.*

**Selection.** Make detailed comparisons of the machines under consideration before purchasing. Cat dealers can estimate component life, preventive maintenance cost, and the true cost of lost production.

**Purchase.** Consider the financing options your Cat dealer offers as well as day-to-day operating costs. Dealer support services can be included in the cost of the machine to yield lower equipment owning and operating costs over the life of the machine.

**Maintenance.** Chose from a wide range of maintenance services at the time of machine purchase. Repair option programs guarantee the cost of repairs up front and help avoid unscheduled repairs that can cost unnecessary time and money.

**Replacement.** Repair, rebuild or replace? Your Cat dealer can help you evaluate the cost involved so you can make the right choice.



**Product Support.** You will find nearly all parts at our dealer parts counter. Cat dealers use a worldwide computer network to find in-stock parts to minimize machine downtime. Caterpillar offers a line of genuine remanufactured components to help lower repair costs.

## Engine

	906		908	
<b>Engine</b>	Cat 3044C		Cat 3044C	
<b>RPM</b>	2600		2600	
	kW	hp	kW	hp
Gross power	56	75	63	84
Net power	51	68	57	76
<b>Dimensions</b>	mm	in	mm	in
Bore	94	3.7	94	3.7
Stroke	120	4.72	120	4.72

Net power rating per ISO 9249 or 80/1269/EEC.

All Caterpillar Compact Wheel Loader engines meet U.S. EPA and European Union non-road emission regulations. Closed circuit breather on 906 and 908 models.

## Power Train, Axles and Brakes

Closed-loop, two-speed hydrostatic single path transmission. Variable displacement pump and variable displacement motor, driving frame-mounted, fixed gear box.

Travel speed	906		908	
	km/h	mph	km/h	mph
Forward/reverse				
Low	7	4	7	4
High	20	12	20	12

### Features

- Fixed front axle with limited slip differential and planetary gear reduction final drives
- 906 service and parking brake are combined in a single, dry-disc driveline brake
- 908 front and rear axles have outboard enclosed wet disc service breaks
- Brake meets ISO 3450:1996

## Service Refill Capacities

	906		908	
	L	gal	L	gal
Cooling System	21	5.5	22	5.8
Fuel tank	74	19.6	80	21
Hydraulic System	66	17	66	17
Engine oil	10	2.6	10	2.6

## Cab

Caterpillar cab, Rollover Protective Structure (ROPS) and Falling Objects Protective structure (FOPS)

- Cab meets OSHA, MSHA and EU regulations for operator sound exposure in effect at the time of manufacture with doors and windows closed
- Operator sound pressure level is below 75 dB(A) when measured per ISO 6396 or 95/27/EC (dynamic)

ROPS meets the following criteria:

- SAE J1040 MAY94
- ISO 3471-1:1986

FOPS meets the following criteria:

- SAE J231 JAN81
- ISO 3449:1992

## Hydraulic System

	906		908	
	L/min	gpm	L/min	gpm
3rd valve flow	68	17.7	83	21.6
Main relief	235 bar	3400 psi	235 bar	3400 psi
<b>Hydraulic cycle time</b>				
Lift	4.5 sec		4.5 sec	
Dump	1.5 sec		2.4 sec	
Lower, float (engine at high idle, rated load in a bucket)	3.2 sec		3.2 sec	



# Operating Specifications

Machine with full fuel tank, ROPS cab, 75 kg (165 lb) operator and standard tires.

	906		908	
Operating weight (ISO 6016:1982)	4960 kg	10,912 lb	6040 kg	13,288 lb
Rated Bucket capacity (ISO 7546:1983)	0.8 m <sup>3</sup>	1.04 yd <sup>3</sup>	1.0 m <sup>3</sup>	1.3 yd <sup>3</sup>
Hydraulic Lift capacity, maximum	41 kN	9,100 lb	44 kN	9,900 lb
Breakout force, bucket	46 kN	10,340 lb	61 kN	13,710 lb
Rated operating load at full turn, bucket (ISO 5998:1986)	1515 kg	3,333 lb	1880 kg	4,136 lb
Straight tipping load, bucket (ISO 8313:1989)	3430 kg	7,546 lb	4380 kg	9,636 lb
Full turn static tipping load, bucket (DIN 24094)	3030 kg	6,666 lb	3760 kg	8,270 lb
Rackback, transport position	53°		56°	
Rated operating load at full turn, forks (EN 474-3, firm and level ground, 1.25 stability and 500 mm/20 in load center)	2015 kg	4,433 lb	2405 kg	5,291 lb
Tipping load at full turn, forks (transport 100 mm/4 in above ground)	2500 kg	5,500 lb	3120 kg	6,860 lb

# Maximum Material Densities

Based on ISO 7546:1983, SAE J742 Feb85 and rated operating loads at full turn.

	Rated Capacity		Dump Height		Maximum Material Density		Bucket Width	
<b>906</b>								
General Purpose	0.8 m <sup>3</sup>	1.0 yd <sup>3</sup>	2425 mm	95 in	1780 kg/m <sup>3</sup>	3,000 lb/yd <sup>3</sup>	1870 mm	74 in
Multi Purpose	0.7 m <sup>3</sup>	0.9 yd <sup>3</sup>	2425 mm	95 in	1780 kg/m <sup>3</sup>	3,000 lb/yd <sup>3</sup>	1870 mm	74 in
Light Material	1.2 m <sup>3</sup>	1.6 yd <sup>3</sup>	2280 mm	90 in	1150 kg/m <sup>3</sup>	1,950 lb/yd <sup>3</sup>	1940 mm	76 in
High Dump	0.7 m <sup>3</sup>	0.9 yd <sup>3</sup>	3490 mm	137 in	1910 kg/m <sup>3</sup>	3,200 lb/yd <sup>3</sup>	1870 mm	74 in
Side Dump	0.7 m <sup>3</sup>	0.9 yd <sup>3</sup>	2325 mm	92 in	1780 kg/m <sup>3</sup>	3,000 lb/yd <sup>3</sup>	1870 mm	74 in
Stone Sieve	0.7 m <sup>3</sup>	0.9 yd <sup>3</sup>	2425 mm	95 in	1950 kg/m <sup>3</sup>	3,300 lb/yd <sup>3</sup>	1870 mm	74 in
<b>908</b>								
General Purpose	1.0 m <sup>3</sup>	1.3 yd <sup>3</sup>	2637 mm	104 in	1880 kg/m <sup>3</sup>	3,760 lb/yd <sup>3</sup>	2050 mm	81 in
Multi Purpose	0.9 m <sup>3</sup>	1.2 yd <sup>3</sup>	2648 mm	104 in	2000 kg/m <sup>3</sup>	3,300 lb/yd <sup>3</sup>	2050 mm	81 in
Light Material	1.5 m <sup>3</sup>	2.0 yd <sup>3</sup>	2429 mm	96 in	1195 kg/m <sup>3</sup>	1,675 lb/yd <sup>3</sup>	2050 mm	81 in
High Dump	0.9 m <sup>3</sup>	1.2 yd <sup>3</sup>	3670 mm	144 in	1960 kg/m <sup>3</sup>	3,230 lb/yd <sup>3</sup>	2050 mm	81 in
Side Dump	0.9 m <sup>3</sup>	1.2 yd <sup>3</sup>	2496 mm	98 in	1880 kg/m <sup>3</sup>	3,105 lb/yd <sup>3</sup>	2050 mm	81 in
Stone Sieve	0.9 m <sup>3</sup>	1.2 yd <sup>3</sup>	2637 mm	104 in	2050 kg/m <sup>3</sup>	3,380 lb/yd <sup>3</sup>	2050 mm	81 in

# Dimensions

Dimensions shown are based on the machine equipped with standard tires and general purpose bucket. All dimensions are approximate.

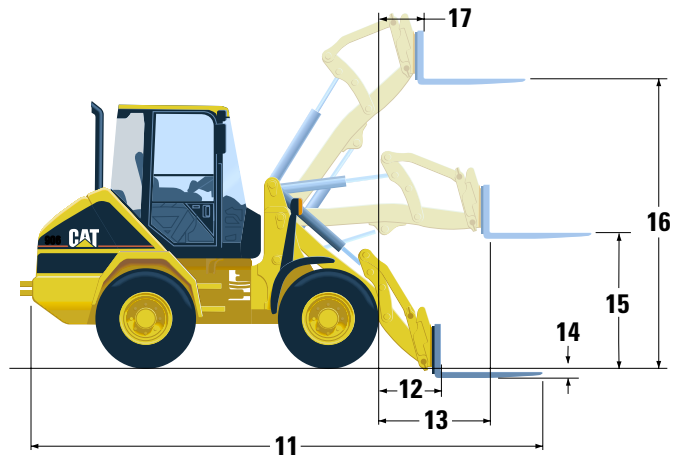
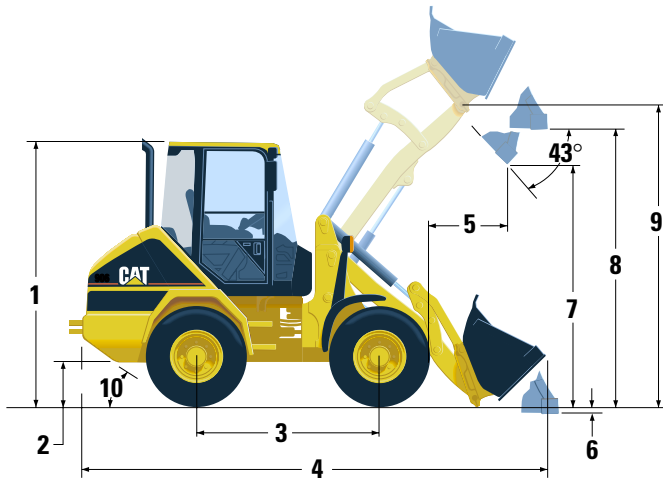

## Standard Tires

<b>906</b>	12.5 - 20
<b>908</b>	14.5 - 20

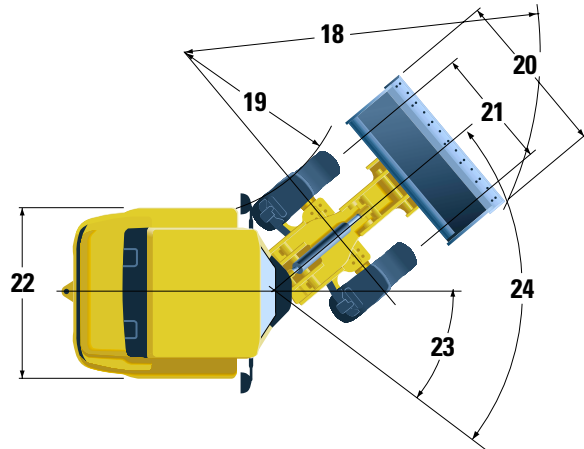

		<b>1</b>	<b>2</b>	<b>3</b>	<b>4</b>	<b>5</b>	<b>6</b>	<b>7</b>	<b>8</b>	<b>9</b>	<b>10</b>	<b>11</b>	<b>12</b>
<b>906</b>	(mm)	2680	420	2000	5040	790	85	2425	2930	3135	34°	5590	770
	(ft/in)	8'9"	1'5"	6'7"	16'6"	2'7"	3"	8'0"	9'7"	10'3"	34°	18'4"	2'6"
<b>908</b>	(mm)	2770	490	2200	5500	902	88	2645	3175	3385	34°	6360	835
	(ft/in)	9'1"	1'7"	7'3"	18'1"	3'0"	3"	8'8"	10'5"	11'1"	34°	20'10"	2'9"
		<b>13</b>	<b>14</b>	<b>15</b>	<b>16</b>	<b>17</b>	<b>18</b>	<b>19</b>	<b>20</b>	<b>21</b>	<b>22</b>	<b>23</b>	<b>24</b>
<b>906</b>	(mm)	1260	55	1420	3010	540	4100	1870	1870	1400	1755	40°	80°
	(ft/in)	4'2"	2"	4'8"	9'11"	1'9"	13'5"	6'2"	6'2"	4'7"	5'9"	40°	80°
<b>908</b>	(mm)	1370	10	1550	3255	600	4475	2060	2050	1575	1960	40°	80°
	(ft/in)	4'6"	0.4"	5'1"	10'8"	2'0"	14'8"	6'9"	6'9"	5'2"	6'5"	40°	80°



---

## Standard Equipment

Standard equipment may vary. Consult your Caterpillar dealer for specifics.

---

Air Cleaner, radial seal, with visual indicator

Alternator, 90-amp

Antifreeze, extended life, -35° C (-31° F)

Battery, 12-volt

Bucket level indicator

Cab, ROPS, sound suppressed, pressurized, includes:

- digital service hour meter
- gauges, fuel level and hydraulic oil temperature
- ground level door releases
- heater/defroster with 11 vents
- lockable tool box
- power sockets, auxiliary
- radio antenna
- right armrest
- seat belt, retractable
- warning indicators, for major systems
- wet wiper, front and rear
- wiring for radio and rotary beacon

Closed circuit breather (906 and 908 only)

Engine hood and side doors, lockable

Front limited slip differential

Hitch, recovery

Hydraulic oil level sight gauge

Proportional Auxiliary Hydraulic Circuit

QuickLock Hydraulic Coupler

Remote jump start terminal

Scheduled oil sampling, S•O•S<sup>SM</sup> ports

---

## Optional Equipment

Optional equipment may vary. Consult your Caterpillar dealer for specifics.

---

Air conditioning

Antifreeze, -50° C (-58° F)

Battery, 12-volt, heavy duty

Cab, comfort, including:

- fabric suspension seat
- sliding window, left hand side
- tilt steering wheel and turning ball

Canopy, ROPS, standard

Creeper control

Custom Color

Eco-drain valves, fuel and hydraulic

Engine block heater, electric

Mud flaps, front (906 only)

No front fenders

Proportional Auxiliary Hydraulic Circuit — joystick mounted

Return to dig

Reverse alarm

Service instructions

Tire options (see price list)

Warning beacon

Worklights, two front, two rear – cab mounted

# 906/908 Compact Wheel Loaders

AEHQ5635-02 (9-06)  
Replaces AEHQ5635-01

For more complete information on Cat products, dealer services,  
and industry solutions, visit us on the web at [www.cat.com](http://www.cat.com)

© 2006 Caterpillar  
All Rights Reserved  
Printed in U.S.A.

Materials and specifications are subject to change without notice.  
Featured machines in photos may include additional equipment.  
See your Caterpillar dealer for available options.

CAT, CATERPILLAR, their respective logos and "Caterpillar Yellow,"  
as well as corporate and product identity used herein, are trademarks  
of Caterpillar and may not be used without permission.

 **CATERPILLAR®**