

# CAT<sup>®</sup> ROTARY MIXERS

RECLAMATION AND STABILIZATION



**CAT<sup>®</sup>**

Courtesy of Machine.Market



RM500

# CAT® ROTARY MIXERS

## HIGH PRODUCTIVITY AND VALUE

### EASIER SERVICE

- Most maintenance items within reach from ground
- Cooling fan easy to clean
- Easy access to hydraulic components
- Electronic Control Modules (ECMs) monitor systems and provide self-diagnosis
- Parts availability, convenient dealer locations

*Lower maintenance and service costs, more uptime, more productivity*

### EASIER OPERATION

- Simple instrumentation is easy to understand
- Controls are conveniently positioned, easy to use, facilitate one-handed operation
- Electronic Monitoring System tracks machine performance and alerts operator to potential issues

*Low training costs, operator can focus on work*



RM300

## SUPERIOR MIX QUALITY

- Rotor options for any job
- Three rotor speeds, selected from operator's station
- Electronic machine control keeps rotor at proper depth and machine at consistent speed
- Electronic control ensures consistent introduction of water or liquid additives

*More precision, more control, easier to use, more options, better quality results in fewer passes*

## DEPENDABLE ROTOR DRIVE SYSTEM

- Automatic lubrication of rotor bearing
- Cat Powershift transmission with hydraulic clutch (RM500)
- Hydraulically engaged clutch, high torque mechanical transmission and drive axle (RM300)
- Mechanical rotor drive system
- Chain drive is self-lubricating, never needs adjustment
- Heavy-duty shear disc or optional torque limiter protects rotor drive

*More durable, simple design, low maintenance, consistent performance*

## BETTER VISIBILITY

- Cab slides to position at either side of machine
- Full visibility to rotor housing and processed material
- Front and rear wiper for cab glass
- Able to mark cut from left or right side

*More precision, more control, better safety*



APPLICATION:  
**RECLAMATION**



## COST-EFFECTIVE REHABILITATION OF ROADS

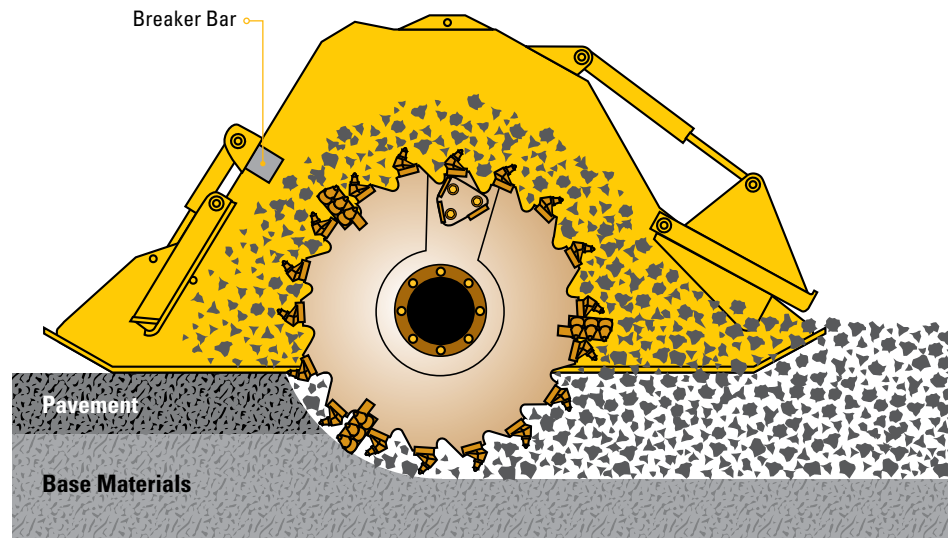

In-place full depth reclamation is growing in use as the worldwide supply of high quality aggregate becomes more scarce and increasingly expensive to haul. Reclamation offers a cost-effective means to recycle the material that is already in place without the time and expense of removing and replacing it. Existing pavements are pulverized in place along with a portion of the existing base materials to form a new homogenous base. Reclamation allows the contractor to not only reuse the materials at hand, but it also provides the opportunity to introduce water or emulsions, and other virgin aggregates to improve the material design. The result is a new, stronger, more uniform base.

Compared with the costs of other rehabilitation methods—overlay or reconstruction—reclamation is the most economical choice over the life of the rehabilitated road.



# IMPROVING THE LOAD-BEARING CAPACITY OF THE SOIL

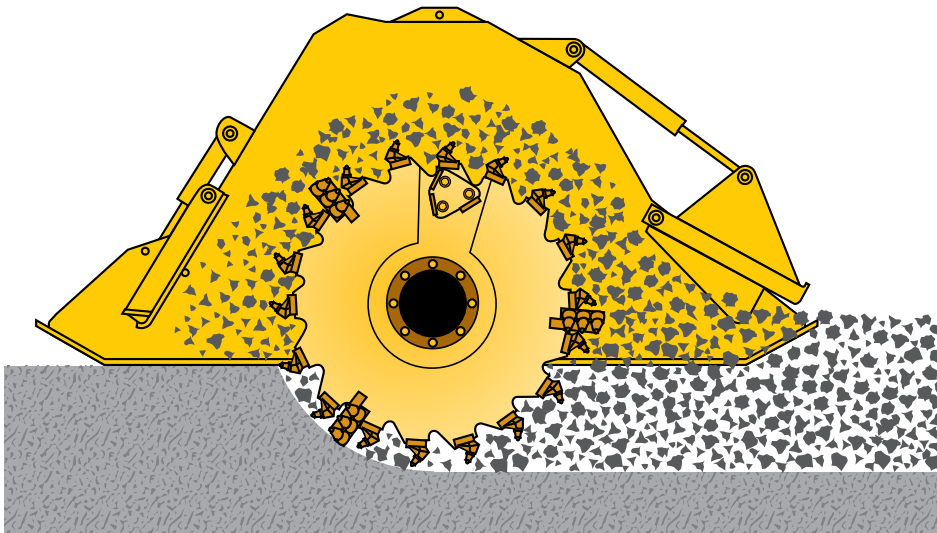

Soil stabilization is the process of mechanically or chemically improving the load-bearing characteristics of the soil. Additives such as fly ash, portland cement and lime are incorporated into cohesive and semi-cohesive native soil to increase compressive strength or reduce plasticity of the subgrade. When performed with the correct additives, stabilization can greatly increase the integrity of the subgrade and provide a material that will have greater support capabilities and moisture resistance.

## SOIL STABILIZATION:

- waterproofs the soil
- improves soil strength
- helps reduce soil volume changes due to temperature or moisture
- improves soil workability
- reduces dust in the jobsite environment
- upgrades marginal materials
- improves durability
- dries wet soils
- conserves aggregate materials
- reduces cost
- conserves energy
- makes it easier for heavy machines to work in poor soils



APPLICATION:  
**SOIL STABILIZATION**

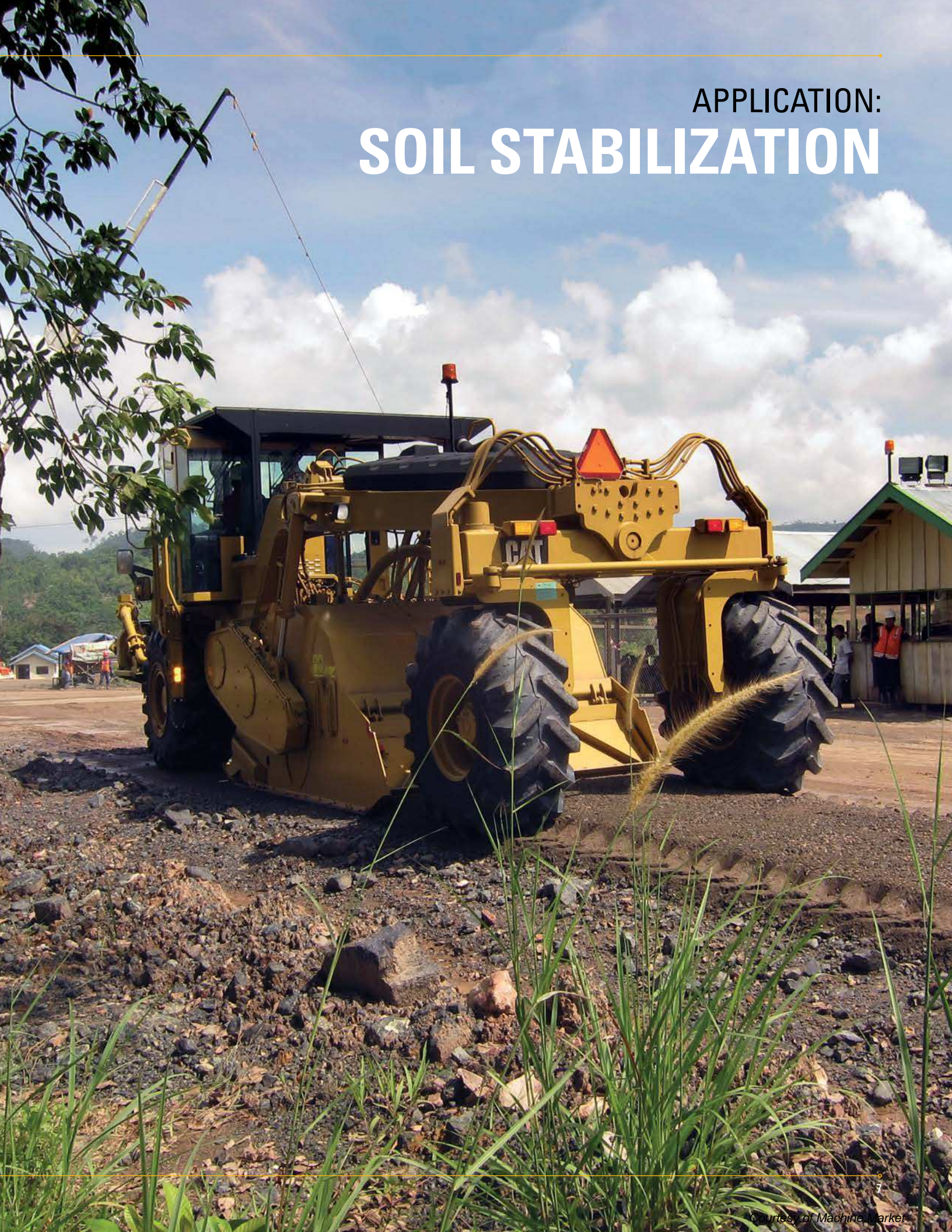

---

# VERSATILITY ALLOWS MULTIPLE USES

## SURFACE MINING



### High Production and Reduced Cost

Although many reclamation and stabilization jobs are tough on equipment, surface mining pushes machine components and reliability to the limit. Rugged Cat rotary mixers are proven to excel in tough mining applications. Whether it's gypsum, salt, coal or surface aggregate, Cat rotary mixers can withstand the rigorous conditions and produce day after day.

## BIO-REMEDIATION



### Helping Nature Help Itself

Concern for the environment has increased the implementation of bio-remediation. In bio-remediation, a rotary mixer is used to blend chemicals, fertilizers and microbes with contaminated soils, water and oxygen. The microbes actively consume the contaminants. The result is a clean, rich material suitable for many construction applications. In many cases, treating soils in place with bio-remediation has proven to be less expensive than removal and off site clean-up.



## AGRICULTURE



### Enhancing the Efficiency of Agriculture

Plantations around the world have found rotary mixers useful for soil turning tasks that require more material processing than standard discs can provide. One example is pineapple plantations in Kenya that use rotary mixers to grind up pineapple tops after harvest and incorporate the material with the soil, leaving a fertile and oxygenated soil for the next planting. This method has proven to be faster and less damaging to the environment than traditional methods of clearing, hauling and burning.

Rotary mixers have a secondary use in agriculture helping to maintain critical haul roads for sub-tropical plantations, often in areas with high clay content.

## HAUL ROADS



### High Strength Roads for Industrial, Governmental or Military Use

Roads are often needed to serve immediate needs: emergency access to disaster areas or roads that connect forestry or mining sites to processing facilities, for example.

Rotary mixers are critical in situations where the need for the road requires the use of in place materials, regardless of their construction quality. A rotary mixer can quickly and dramatically improve the load bearing capacity of soils, and also minimize any impact the construction will place on the environment.

# ROTOR OPTIONS

## DESIGNED FOR EFFICIENT PRODUCTION

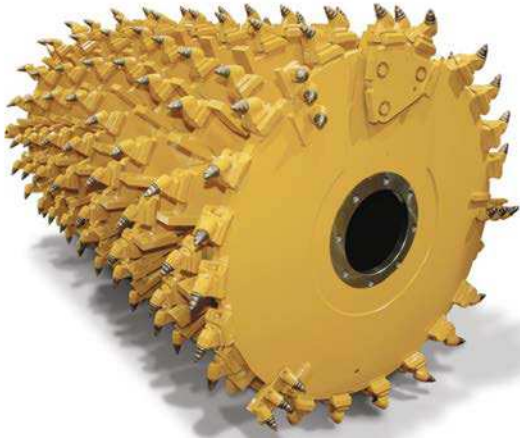

### UNIVERSAL ROTOR

*Note: Universal Rotor offering dependent on region. Consult your dealer.*

Universal Rotor 16" (41 cm) for asphalt is designed to produce maximum breakout force in severe asphalt cuts and on existing soil cement. The kicker paddle design provides material movement and suspension in the mixing chamber for achieving excellent gradation in full-depth reclamation applications. It may also be used in soil stabilization applications; however, the 200 bit design may result in gradation that is finer than desirable. The large number of bits, along with the kicker paddles, will also cause this rotor to consume the most power for soil applications.

Universal Rotor 18" (46 cm) is designed to provide maximum mixing depth. It has lower breakout force compared to the Universal Rotor 16". This rotor meets European 45 cm mixing depth requirements while

providing the highest level of material pulverization and gradation. It has a secondary application of light asphalt reclamation, where the asphalt layer is thin and deteriorated.

Universal Rotors come with Breaker Bars to optimize material sizing.



**Triple-tree cutting bit placement on rotor ends cleans up loose material and reduces wear on the rotor caused by maneuvering in the cut.**



### COMBINATION ROTOR

Designed primarily for stabilization applications in cohesive soils, the Combination Rotor excels in deep-cut soil mixing applications where pulverization and gradation is of lesser importance than higher working speeds. Performs well in cohesive soils and has a secondary application of surface mining for non-engineered substances such as coal, shale, or limestone. Also can handle light reclamation applications where the asphalt layer is thin and deteriorated.

The design utilizes a smaller number of bits, which contributes to lower costs associated with bit replacement. This rotor design results in high production—especially in deep cuts—because less power is required to drive a rotor with fewer bits compared to a rotor with significantly more.

The Combination Rotor will produce larger material sizing compared to the Soil Rotor due to the smaller number of bits.

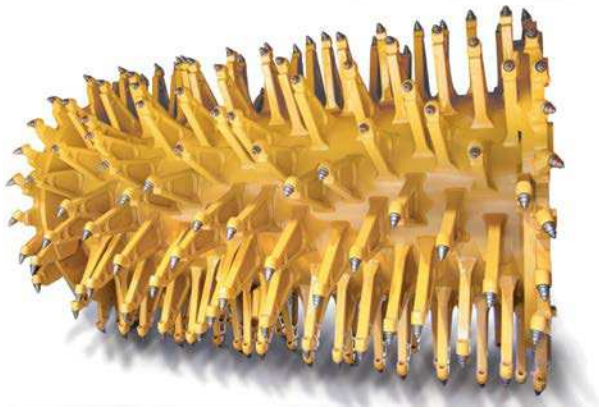

## SOIL ROTOR

Designed primarily for soil stabilization applications in semi-cohesive or granular soils, the Soil Rotor is an ideal choice for mixing additives with semi-cohesive or granular materials where soil gradation is critical.

The rotor is equipped with cast stand-offs that include bit holders in a single casting. Worn or damaged bit holders can be removed and replaced with weld-on bit holders. Bit life varies depending on soil type.



## SPADE ROTOR

Designed for soil stabilization applications, the Spade Rotor blends additives with cohesive, semi-cohesive or granular materials. 58 carbide-faced quick change spade bits provide long service life and are easily replaced due to a single nut and bolt connection. This design allows the tool to break away if it strikes a solid object, preventing damage to the rotor and the rotor drive train.

### Bolt-on Breakaway Cutting Bit Holder

Used on Universal Rotor

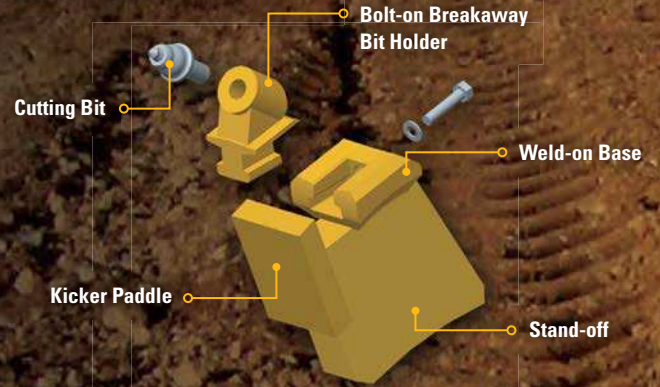

### Bolt-on Breakaway Cutting Bit Holder

Used on Combination Rotor

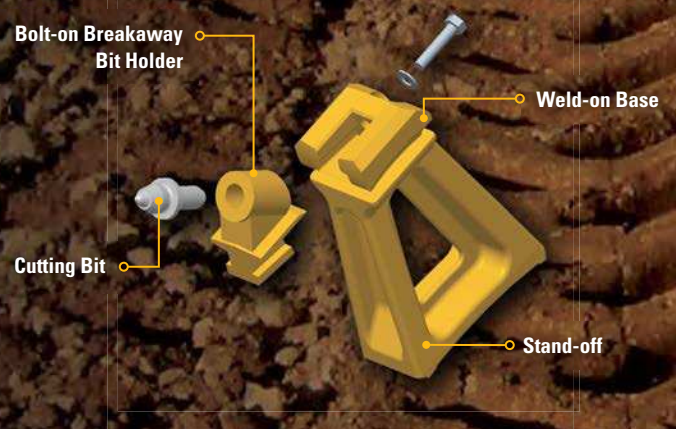

### Weld-on Cutting Bit Holder

Used on Soil Rotor and Spade Rotor

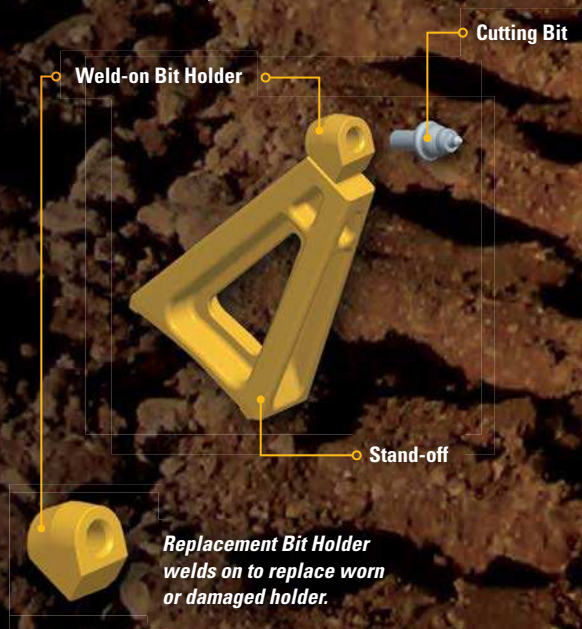



# MAXIMIZE PERFORMANCE

## CHOOSE THE BEST ROTOR FOR THE APPLICATION

While most rotors are capable of producing good results in many applications, each is designed to provide maximum efficiency and productivity when performing a specific application. This chart provides general guidance when choosing a rotor or ascertaining the performance of a rotor for a certain application.

Job Type	Specific Application	Universal 16	Universal 18	Combination	Soil	Spade
Reclamation	Full-Depth Asphalt					
	Thin Asphalt Layer 25-75 mm (1-3 in)	●	●	◐	◐	◐
	Medium Asphalt Layer 75-175 mm (3-7 in)	●	●	◐	○	○
	Thick Asphalt Layer 175-250 mm (7-10 in)	●	◐	○	○	○
	Soil and Cement (fully cured)	●	●	◐	○	○
Soil	Mixing/Stabilization					
	Granular Soils	●	●	◐	●	●
	Granular with rocks < 130 mm (5"), debris	●	●	◐	○	●
	Light Clay	◐	◐	●	●	●
	Heavy Clay/Gumbo	○	○	●	◐	●
Surface Mining	Coal	◐	◐	●	○	○
	Shale	◐	◐	●	○	○
	Limestone	◐	○	●	○	○
Rental	General Purpose	●	◐	●	○	●

- Rotor is an ideal choice for specific application
- ◐ Rotor performance is acceptable, but not ideal
- Rotor is not recommended for this application



# CUTTING BIT COMPATIBILITY

Optimize performance for maximum productivity.

Choosing the best cutting bit for your application can optimize the efficiency of the machine, resulting in more production with ideal material sizing and mixing quality. The charts here can help you choose cutting bits based on their suitability for various common reclamation, stabilization and mining tasks.

For more information or cutting tool alternatives, please consult your local Cat dealer or refer to the *Cutter Bit Reference Guide* (PEBJ0011).

	Universal 16	Universal 18	Combination	Soil	Spade
<b>Cut Width</b>	2438 mm (96 in)	2438 mm (96 in)	2438 mm (96 in)	2438 mm (96 in)	2300 mm (90.6 in)
<b>Rotor Diameter (over bits)</b>	1375 mm (54 in)	1525 mm (60 in)	1625 mm (64 in)	1625 mm (64 in)	1575 mm (62 in)
<b>Maximum Depth</b>	406 mm (16 in)	457 mm (18 in)	508 mm (20 in)	508 mm (20 in)	457 mm (18 in)
<b>Weight</b>	4080 kg (9,000 lb)	4355 kg (9,600 lb)	3085 kg (6,800 lb)	3855 kg (8,500 lb)	2313 kg (5,100 lb)
<b>Number of Cutting Bits</b>	200	200	114	238	58
<b>Bit Impact Spacing</b>	15.9 mm (0.625 in)	15 mm (0.6 in)	32 mm (1.25 in)	11.5 mm (0.45 in)	171 mm (6.75 in)
<b>Bit Holder Type</b>	Bolt-on Breakaway	Bolt-on Breakaway	Bolt-on Breakaway	Weld-on	Weld-on
<b>Bit Shank Diameter</b>	19 mm (¾ in)	19 mm (¾ in)	22 mm (⅞ in)	19 mm (¾ in)	D-Shank
<b>Direction of Cut</b>	Up	Up	Up	Up	Up



Part No	Rotor Type			
	UNIVERSAL 19 mm (¾ in) Shank	STABILIZATION 19 mm (¾ in) Shank	COMBINATION 22 mm (⅞ in) Shank	SPADE D-Shank, 22 mm (⅞ in) Bolt
117-3884			x	
316-6084			x	
149-5763	x	x		
415-3935	x	x		
077-4018				x

Part No	Application				Depth		
	Soil	Surface Mining Harder Materials	Surface Mining Softer Materials	Asphalt Reclamation	Shallow 25-50 mm (1-2 in)	Moderate 75-125 mm (3 - 5 in)	Deep +150 mm (+6 in)
117-3884	x				x		
316-6084	x					x	x
149-5763		x				x	x
415-3935	x		x	x	x	x	x
077-4018	x						



## ENHANCING CAPABILITY

# OPTIONAL EQUIPMENT

### TORQUE LIMITER

The torque limiter minimizes the amount of torque that can be transferred to the engine. This allows the mechanism to limit potential damage when the rotor strikes an immovable object like a manhole cover.

**Available on RM300 and RM500.**

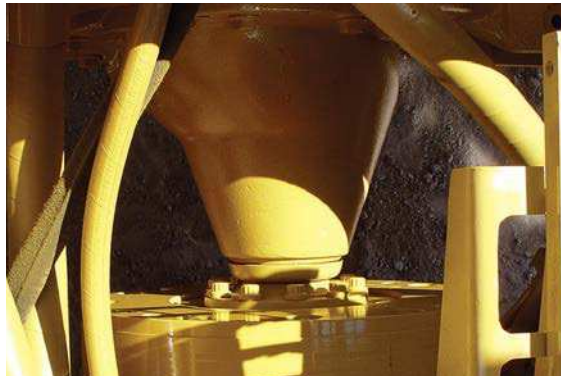

### BOLT-ON COUNTERWEIGHT

Bolt-on 1600 kg (3,500 lb) counterweight kit enhances machine performance in tough reclamation applications. Recommended for asphalt cuts 25 cm (10 in) deep or greater.

**Available for RM500 only.**

### WARNING BEACON

Amber strobe beacon required on many job sites. Mounted on retractable pole.

**Available on RM300 and RM500.**  
Requires Working Lights package.



### PRODUCT LINK™

Product Link gathers and wirelessly transmits key machine data via cellular and satellite communications from the machine to Equipment Manager which can be accessed remotely through a secure web based application hosted on the dealer website.

**Available on RM300 and RM500.**  
Subscription required. Speak to your Cat dealer for details.





## WATER SPRAY AND EMULSION SPRAY SYSTEM

Both Water Spray System and Emulsion Spray Systems installed to allow simultaneous or individual system operation.

**Available for RM500 only.**

## EMULSION SPRAY SYSTEM

Emulsion Spray System automates the addition of metered emulsion to the mixing chamber, allowing the machine to easily mix the proper measured amount to the materials. This pump unit provides an infinitely variable volume capacity of 114 to 757 liters (30 to 200 gallons) per minute. Three sets of nozzles on the spray bar ensure proper fan pattern.

**Low Range Nozzle:** 114 - 208 liters (30 - 55 gal) per min.

**Medium Range Nozzle:** 132 - 416 liters (35 - 110 gal) per min.

**High Range Nozzle:** 284 - 776 liters (75 - 205 gal) per min.

**Available on RM300 and RM500.**



## WATER SPRAY SYSTEM

Water Spray System automates the addition of metered water to the mixing chamber, allowing the machine to easily mix the proper measured amount to the materials. It provides an infinitely variable volume capacity of 114 to 1836 liters (30 to 485 gallons) per minute with two nozzles that provide a high flow range and a low flow range.

**Low Range Nozzle:** 114 - 1079 liters (30 - 285 gal) per min.

**High Range Nozzle:** 227 - 1836 liters (60 - 485 gal) per min.

**Available on RM300 and RM500.**

For water use only—not for use with emulsions.

## MIRROR PACKAGE

Required in many countries. Mirror package enhances visibility to front tires and front of the machine, as well as along the sides. Includes 8 adjustable mirrors.

**Available on RM300 and RM500.**



## ROADING LIGHTS

Roading Lights package enables on-highway transportation. Package includes 2 front-facing headlights, side amber turn signal/hazard lamps (2 front, 2 rear), and a slow moving vehicle sign.

**Available on RM300 and RM500.**



## ROTOR DOOR CAMERA

Provides operator with remote view to rear chamber door, allowing easy monitoring of machine operation and material sizing.

**Available for RM300 and RM500.**

Rotor Door Camera option requires Rear Vision Camera option.



## COMMISSIONING SUPPORT

Certified Caterpillar trainers cover proper machine setup, basic maintenance, operation and application. Training lasts approximately 3 days and is conducted at the customer's location or jobsite.

**Available for RM300 and RM500.**

## FOPS

Falling Object Protective Structure provides Level 1 protection. Bolts on to ROPS structure and also serves as a sun canopy. Requires ROPS.

**Available on RM300 and RM500.**  
Requires ROPS option.



## UMBRELLA

Large umbrella provides the operator with shade from sun or protection from rain. Umbrella measures 1.4 m x 1.4 m (54" x 54") and includes support shaft and mounting hardware. Collapses for storage. For use on open platform configurations.

**Available on RM300 and RM500.**  
Cannot be used with ROPS, FOPS or Cab.



## ROPS

Two-post Roll Over Protective Structure bolts directly onto flanges welded behind operator's platform.

**Available on RM300 and RM500.**

# ARMOR AGAINST ABRASION AND FRICTION

# WEAR PARTS

## WEAR DISC

Disc installs inside rotor chamber on each side of rotor drum to provide protection and guide the depth adjustment of the rotor chain drive while keeping material inside chamber.

**Available on RM300 and RM500.**

Part Number: 231-4209 (Order Quantity: 2)

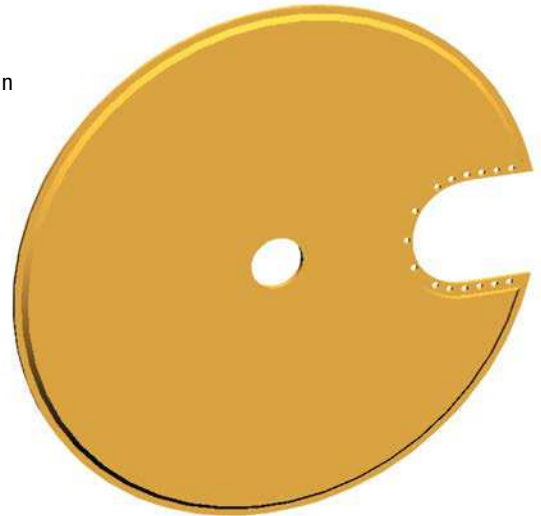

## CHAMBER GROUP (WEAR SKIS)

Steel skis mount to bottom of rotor chamber. Provides protection from ground friction on main chamber housing.

**Available on RM300 and RM500.**

Part Numbers:

Center Plate 140-1188 (Order Quantity: 2)

Front and Back Plate 140-1187 (Order Quantity: 4)

## BREAKER BAR

Steel assembly mounts inside of rotor chamber. For use with Universal 16" and Universal 18" rotors. Provides more control over material sizing by keeping material in the chamber longer and acting as a crushing agent against which larger chunks of material can be broken down.

**Available on RM300 and RM500.**

Part Number: 193-1039 (Order Quantity: 3)

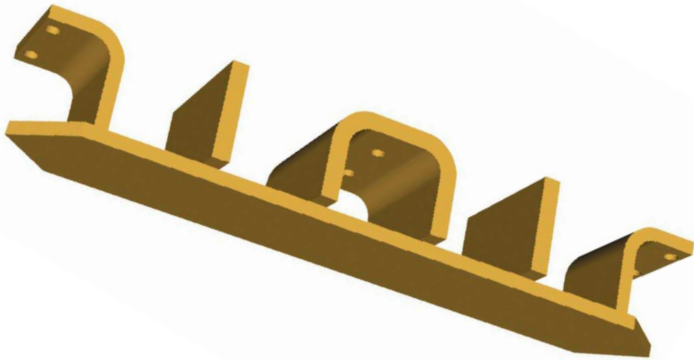

## REAR DOOR STRIKE OFF

Strike off installs on rear chamber door. Provides protection for rear door from friction caused by dragging in material. Reversible design extends use.

**Available on RM300 and RM500.**

Part Number: 077-7730 (Order Quantity: 1)

# RM300

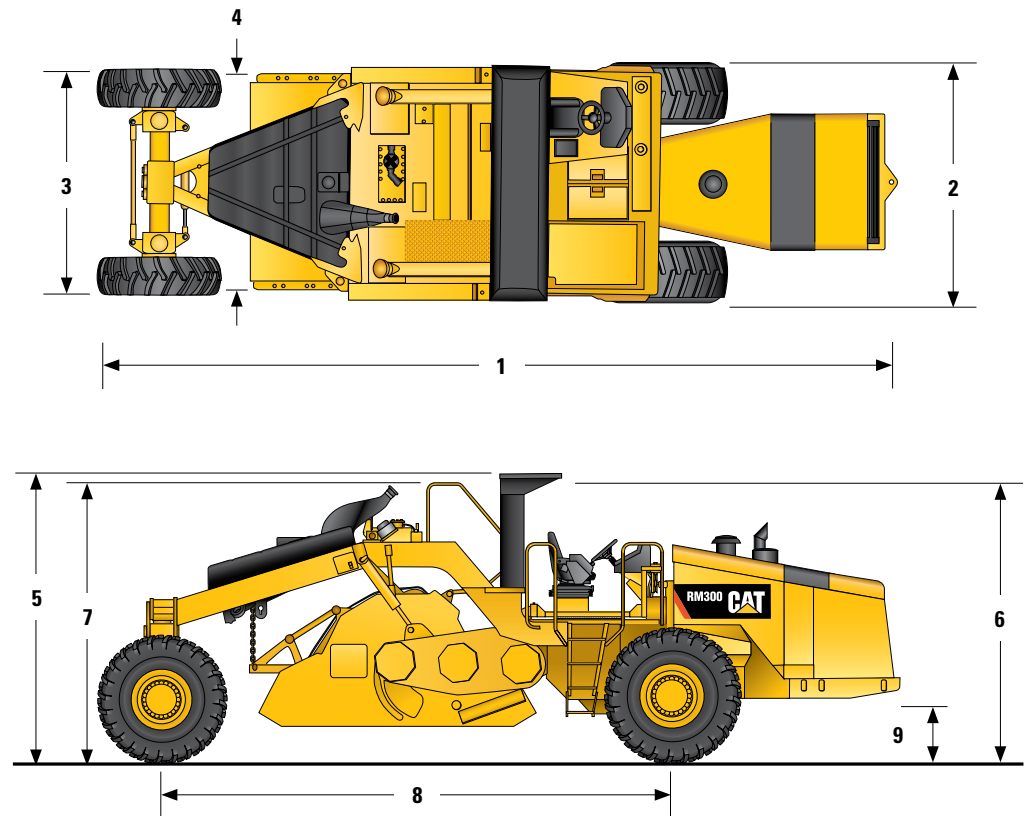

## Dimensions

1 Overall Length	10 m	32.83 ft
2 Overall Width	3 m	9.83 ft
3 Width at Rear Wheels	2.82 m	9.17 ft
4 Rotor Hood Width	2.73 m	8.92 ft
5 Height at ROPS	3.5 m	11.5 ft
6 Height at Cab (if equipped)	3.4 m	11.17 ft
7 Height at Handrail	3.37 m	11.08 ft
8 Wheelbase	6.32 m	20.75 ft
9 Ground Clearance	720 mm	28.3 in
Inside Turning Radius	3.9 m	12.83 ft

## Weights

Operating Weight w/ ROPS/FOPS		
w/ Universal Rotor 16"	24 198 kg	53,349 lb
w/ Universal Rotor 18"	24 474 kg	53,949 lb
w/ Combination Rotor	23 149 kg	51,034 lb
w/ Spade Rotor	22 430 kg	49,449 lb
Operating Weight w/ ROPS cab		
w/ Universal Rotor 16"	24 454 kg	53,911 lb
w/ Universal Rotor 18"	24 729 kg	54,511 lb
w/ Combination Rotor	23 404 kg	51,596 lb
w/ Spade Rotor	22 685 kg	50,011 lb

## Rotor Drive Specifications

Rotor Speeds @ 2000 engine rpm	
First	106 rpm
Second	144 rpm
Third	216 rpm

## Engine - Power Train

Engine Model	Cat® C11 with ACERT™	
Global Emissions	US EPA Tier 3/EU Stage IIIA	
Gross Power	261 kW	350 hp
Displacement	11.1 L	680 in³
Stroke	140 mm	5.5 in
Bore	130 mm	5.1 in
Max. Travel Speed (Forward or Reverse)	9.7 km/h	6 mph

## Service Refill Capacities

Fuel Tank, total capacity	1056 L	279 gal
Cooling System	62.5 L	16.5 gal
Engine Oil w/ Filter	32 L	8.5 gal
Propel Planetary Gear Reducer (ea.)		
Front	5 L	1.3 gal
Hydraulic Tank (service refill)	233 L	61.5 gal
Rotor Drive Axle	17 L	4.5 gal
Rotor Axle Hub (ea.)	3.8 L	1 gal
Rotor Bearing Reservoir	2 L	0.5 gal
Chain Case (ea.)	25.6 L	6.8 gal
Rotor Transmission	5.7 L	1.5 gal

# RM500

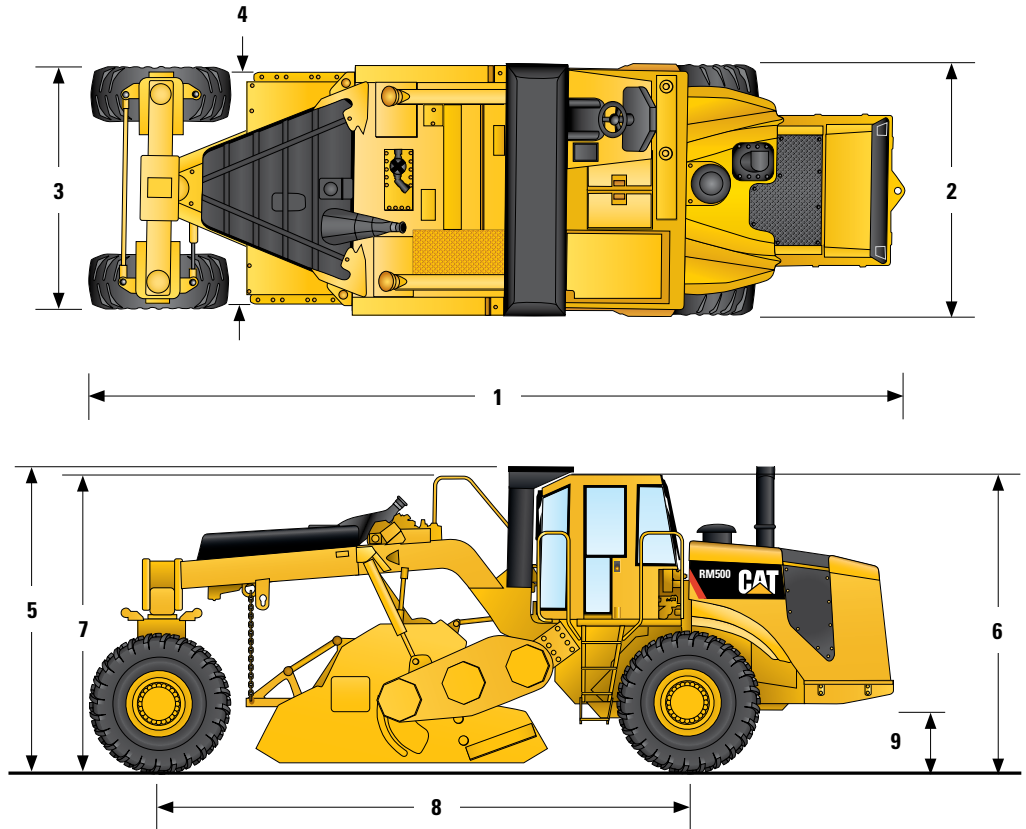

## Dimensions

1 Overall Length	9.68 m	31.67 ft
2 Overall Width	2.98 m	9.58 ft
3 Width at Rear Wheels	2.82 m	9.17 ft
4 Rotor Hood Width	2.53 m	8.25 ft
5 Height at ROPS	3.48 m	11.33 ft
6 Height at Cab (if equipped)	3.39 m	11.08 ft
7 Height at Handrail	3.36 m	11 ft
8 Wheelbase	6.25 m	20.42 ft
9 Ground Clearance	530 mm	20.8 in
Inside Turning Radius	3.7 m	12.08 ft

## Weights

Operating Weight w/ ROPS/FOPS		
w/ Universal Rotor 16"	27 890 kg	61,400 lb
w/ Universal Rotor 18"	28 165 kg	62,000 lb
w/ Combination Rotor	26 895 kg	59,200 lb
w/ Soil Rotor	27 665 kg	60,900 lb
Operating Weight w/ ROPS cab		
w/ Universal Rotor 16"	28 145 kg	62,060 lb
w/ Universal Rotor 18"	28 440 kg	62,660 lb
w/ Combination Rotor	27 150 kg	59,860 lb
w/ Soil Rotor	27 920 kg	61,560 lb

## Rotor Drive Specifications

Rotor Speeds @ 2000 engine rpm	
First	110 rpm
Second	152 rpm
Third	205 rpm

## Engine - Power Train

Engine Model	Cat® C15 with ACERT™	
Global Emissions	US EPA Tier 3/EU Stage IIIA	
Gross Power	403 kW	540 hp
Displacement	15.1 L	923 in <sup>3</sup>
Stroke	171 mm	6.7 in
Bore	137 mm	5.4 in
Max. Travel Speed (Forward or Reverse)	9.2 km/h	5.7 mph

## Service Refill Capacities

Fuel Tank, total capacity	1056 L	279 gal
Cooling System	81 L	21.4 gal
Engine Oil w/ Filter	34 L	8.9 gal
Propel Planetary Gear Reducer (ea.)		
Front	5 L	1.3 gal
Rear	4 L	1 gal
Hydraulic Tank (service refill)	233 L	61.5 gal
Rotor Drive Axle	17 L	4.5 gal
Rotor Bearing Reservoir	12 L	3.2 gal
Chain Case (ea.)	25.6 L	6.8 gal
Rotor Drive Planetary Gear Reducer (ea.)	3.8 L	1 gal
Rotor Transmission	12.4 L	3.25 gal



## **THE CAT PROMISE**

**PERFORMANCE. RELIABILITY. VALUE.**

Cat RM300 and RM500 Rotary Mixers deliver outstanding performance in a wide range of applications. High productivity, coupled with legendary Cat reliability, provides our customers with extraordinary value.

**BUILT FOR IT.**

©2013 Caterpillar | All Rights Reserved | QEDQ1517-02 (06/13)  
CAT, CATERPILLAR, BUILT FOR IT, their respective logos, "Caterpillar Yellow," the "Power Edge" trade dress as well as corporate and product identity used herein, are trademarks of Caterpillar and may not be used without permission.



*Courtesy of Machine.Market*