

RM500

Rotary Mixer



Cat® C15 Engine with ACERT™ Technology

Gross Power (SAE J1995) at 2000 rpm 403 kW/548 hp

Net Power (ISO 9249) at 2000 rpm 403 kW/548 hp

Rotor Width 2438 mm

Rotor Depth (maximum) 508 mm

Operating Weight (with ROPS and cab)

with universal rotor 28 410 kg

with combination rotor 27 150 kg

Productivity, Serviceability and Comfort in a Durable Package

The new RM500 offers enhanced production capabilities, optimized performance, simplified service and exceptional operator comfort.

C15 Engine with ACERT™ Technology

ACERT™ Technology works at the point of combustion to optimize engine performance and provide low exhaust emissions. The C15 engine with ACERT Technology provides clean burning power. Electronically controlled on-demand variable speed cooling fan provides the lowest overall noise levels and high ambient operation capability. **pg. 4**

Cab

The optional cab increases machine utilization, provides greater year-round comfort and offers reduced interior sound levels. The pressurized cab slides side-to-side and includes a rotating cloth seat, left and right side doors, tinted windows, front and rear windshield wipers, heater/defroster and air conditioning. Sound absorbing floor mat reduces sound and machine vibration transmitted to the operator. **pg. 6**

Operator's Station

Ergonomic design emphasizes comfort, visibility and easy operation. Isolated operator's station with heavy-duty rubber mounts reduce machine vibration transmitted to the operator. The hydraulically-assisted platform slides side-to-side to an infinite number of positions. A switch on the side console allows the operator to select any desired position for good visibility and comfort. The fully adjustable steering column and rotating seat are positioned to provide an optimal operating position. Machine controls are grouped and conveniently located to enhance operator productivity and reduce fatigue. **pg. 5**

Serviceability

The one-piece fiberglass hood tilts forward for exceptional access to the engine and cooling system. Daily service points are accessible from ground level and are grouped on one side of the engine. Hinged ground level side panels allow total engine access. Hinged service doors open wide for access to power train and rotor drive components. The rotor hood tilts forward to allow access to the rotor and cutting tools. Ground level side access doors on the rotor hood provides convenient access for easy cutting tool removal and replacement. **pg. 11**

Performance and reliability you expect.

The RM500 combines superior performance and reliability to achieve the most demanding job specifications while maximizing machine uptime. With many enhanced features and options, the RM500 is designed to work well in both full depth reclamation and soil stabilization applications.



Rotor Drive

A Caterpillar® powershift transmission drives the rotor and provides three rotor speeds for maximum performance in a variety of materials and cutting depths. Heavy-duty shear disc or optional torque limiter protects rotor drive components from torsional stress and shock loads. **pg. 8**

Dual Propel Pumps

The dual propel pumps provides a separate balanced hydraulic flow to both the rear and front drive motors to propel the machine with full-time. This system enables the operator to achieve superior tractive effort for soil stabilization applications that require maximum cutting depth and that are also high in moisture content. **pg. 8**

Mixing Chamber

Mixing chamber allows the rotor to move independently so that the capacity of the chamber actually increases in deeper cuts to allow better material mixing and excellent gradation. Machine weight is well distributed to provide stability in the cut for uniform depth control. **pg. 9**

Rotor Options

With a choice of two rotor options, the RM500 can be configured for different applications and depth specifications. The universal rotor is intended primarily to pulverize asphalt layers. The combination rotor is intended primarily for use in soil stabilization with secondary application in light cuts of asphalt reclamation. **pg. 10**



C15 Engine with ACERT Technology

A combination of innovations working at the point of combustion, ACERT Technology optimizes engine performance while meeting European EU Stage IIIA emission regulations for off-road applications.



Cat C15 Engine with ACERT Technology.

The C15 engine provides a full-rated gross power (SAE J1995) of 403 kW at 2000 rpm with a torque of 2356 Nm. The combination of large displacement and high torque allow the RM500 to popel through the toughest materials.

Mechanically-Actuated Electronically Controlled Unit Injection (MEUI).

The MEUI fuel system is a unique system that combines the technical advancement of an electronic control system with the simplicity of direct mechanically controlled unit fuel injection. The MEUI system excels in its ability to control injection pressure over the entire engine operating speed range. These features allow the C15 to have complete control over injection timing, duration and pressure.

Multiple Injection Fuel Delivery.

Multiple injection fuel delivery involves a high degree of precision. Precisely shaping the combustion cycle lowers combustion chamber temperatures, which generates fewer emissions, optimizes fuel combustion; translating into more work output for your fuel cost.

C15 Cylinder Block. The cylinder block is a one-piece, grey iron block that features generous ribbing for stiffness and heavy bearing bulkheads for rigidity and strength as the crankshaft turns. This new design supports the engine's higher compression ratios and increases its power density. The incorporation of straight-thread, o-ring connection points reduces the loss of engine oil and fluids.

High Cylinder Pressures. High cylinder pressures combined with tightly controlled tolerances promote extremely efficient fuel burn, less blow by and lower emissions.

Service, Maintenance and Repair.

Easier service, maintenance and repair is accomplished by monitoring key functions and logging critical indicators. Advanced electronic diagnostic capabilities are possible using Cat Electronic Technician.

Turbocharged and Air-to-Air Aftercooling (ATAAC). The turbocharged air-to-air aftercooling system provides high horsepower with increased response time while keeping exhaust temperatures low for long hours of continuous operation.

Air-to-Air Aftercooling. Air-to-air aftercooling keeps air intake temperatures down and in concert with the tight tolerance combustion chamber components, maximizes fuel efficiency and minimizes emissions. New turbocharger, unique cross-flow head, single, rear driven, overhead cam and a more efficient intake manifold generate significant improvements in air flow. This generates significant improvements in efficiency and reduced emissions.

ADEM™ A4 electronic Control Module.

The ADEM A4 electronic control module manages fuel delivery, valve timing and airflow to get the most performance per liter of fuel used. The control module provides flexible fuel mapping, allowing the engine to respond quickly to varying application needs. It keeps track of engine and machine conditions while keeping the engine operating at peak efficiency.

Operator's Station

Ergonomic design emphasizes operator comfort, visibility and easy operation.

The sliding platform slides side-to-side to increase versatility and productivity while reducing operator fatigue.



The side console features a padded arm rest, four-mode steering switch, speed control dial, propel lever, rotor elevation, front and rear rotor hood door switches, rear steering switch and sliding operator's station switch.

Hydraulically-assisted sliding platform. The operator can position the platform to any desired position to provide clear, all-around visibility to both sides of the machine. Platform can be accessed from either side of the machine.

Comfortable and durable seat. The seat has adjustable fore/aft position, bottom cushion height, suspension stiffness and flip-up arm rests. Seat and side control console rotates to seven positions to enhance operator comfort.

Controls are conveniently located for easy one-handed control while seated. Propel lever with center detent allows forward/reverse operation and variable machine speed.

Adjustable steering column. The telescoping and tilt feature of the steering column provides a comfortable operating position for the operator.

Operational Controls

All machine controls, switches and gauges are positioned to minimize operator fatigue and maximize productivity.



- | | |
|--------------------------------|---------------------------------|
| 1 Electronic Monitoring System | 6 Load Control Selection Switch |
| 2 Ground Speed Indicator | 7 Rotor On/Off Switch |
| 3 Engine Tachometer | 8 Engine Speed Switch |
| 4 Park Brake Switch | |
| 5 Propel Speed Selector Switch | |

Clear instrumentation. Includes gauges for engine oil pressure, engine coolant temperature, hydraulic oil temperature, rotor drive transmission oil temperature, charging system voltage and fuel level.

Large analog gauges. Large gauges display propel ground speed, engine rpm, engine hour meter and fault codes.

Electronic monitoring system. Input signals are constantly monitored from sensors and switches in various machine systems and operator is alerted if a problem occurs.

Load control selection switch. Controls propel speed manually or automatically by the ECM.

Automatic steering control. Four steering modes enable maneuvering in tight quarters: front steer only, crab steer, coordinated steer and rear steer only.

Sliding Cab

Optional cab can increase machine utilization and provides greater year-round comfort in extreme environment conditions. The cab is fully pressurized and includes air conditioning.



Pressurized iso-mounted cab. Maintains noise, dust and the elements out, and comfort in.

Fully-equipped cab. Items included with cab are: rotating cloth seat, left and right side lockable doors, tinted glass, air conditioning, heater/defroster, dual front and rear windshield wipers and sound absorbing floor mat.

Additional operator comforts. The cab also includes two cup holders and a 12-volt power receptacle. The cab is also radio-ready and includes a power converter, antenna with cable, two speakers and a headliner location for mounting radio.

Excellent all-round visibility. The cab offers an exceptional viewing area to the front tire edge, mixing chamber and to the rear wheels.

The following features further enhance operator comfort;

- 1 Heating/air conditioning controls
- 2 Left and right access doors
- 3 Rotating cloth seat
- 4 Sound absorbing headliner
- 5 Tinted glass
- 6 Windshield wipers
- 7 Cushioned floor mat
- 8 Dual front mounted speakers
- 9 Radio-ready mount
- 10 Heavy-duty isolation mounts



Electronic Control Modules

Reliable field-proven technology makes machine operation simple and self-diagnostics simplifies troubleshooting.



Reliable field-proven technology. Field-proven technology provides maximum productivity and simplifies troubleshooting.

Electronic Control Module (ECM). Input signals from sensors in the engine, propel, steering and rotor drive systems monitor current operating conditions.

Self-diagnostics. Provides information for troubleshooting and alerts the operator of potential system problems.

Automatic load control. The load control system automatically adjusts propel speed so that engine speed does not drop below 1900 rpm. Machine always works at peak efficiency for maximum output.

Automatic rotor depth control. Provides consistent quality and performance.

Propel System

Hydrostatic drive provides balanced full-time tractive effort to each drive motor.

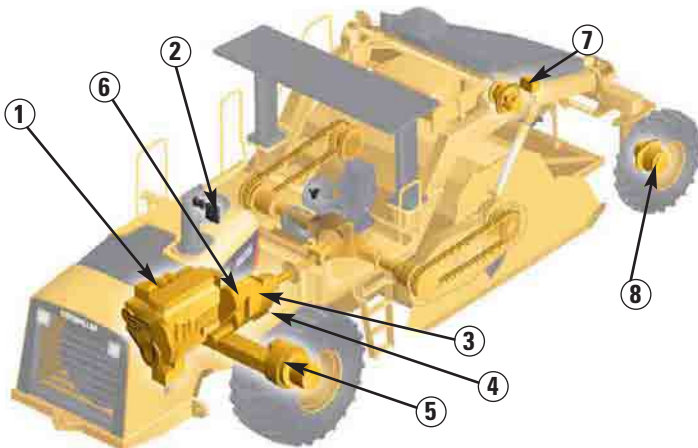

1 Caterpillar C15 Engine
2 Electronic Control Modules
3 Front Wheel Propel Pump
4 Front Flow Divider Control Valve

5 Front Wheel Drive Motor
6 Rear Wheel Propel Pump
7 Rear Flow Divider Control Valve
8 Rear Wheel Drive Motor

Optimum tractive effort. The dual propel pumps provide separate balanced flow to the front and rear dual displacement drive motors. Superior tractive effort is achieved in soft underfoot conditions.

Load sensing system. The Electronically Controlled Module (ECM) matches propel speed to the load on rotor.

Two speed ranges. The machine operates at either maximum torque to propel the machine through the toughest conditions or a faster speed for moving around the job site.

Infinitely variable machine speed. The propel lever and speed dial control infinitely variable machine speed.

Dual flow divider control valves. Equal hydraulic oil flow to each drive motor increases tractive effort in slippery conditions.

All-Wheel-Drive

A separate hydraulic pump provides hydraulic flow to large displacement motors on each wheel. The system propels the machine with full-time all-wheel drive.



Dual propel pump system. One pump is dedicated to drive the front wheels, while the second propel pump is dedicated to drive the rear wheels.

Superior tractive effort. Increased tractive effort for those tough soil or reclamation jobs.

Flow divider control valve. Equal hydraulic flow to each rear wheel to provide all-wheel drive.

Four-wheel drive. High torque large displacement motors on rear wheels makes this a true four-wheel drive machine.

Large rear tyres. Tyres with an aggressive tread and large footprint propels the machine easily in the most severe applications.

Rotor Drive

Maximum production with high reliability. A Caterpillar powershift transmission provides three rotor speeds for maximum performance in a variety of materials and cutting depths.

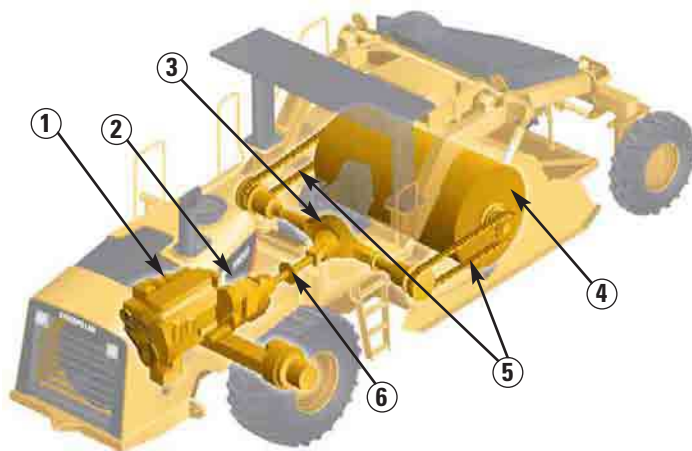

- 1 Caterpillar C15 Engine
- 2 Transmission
- 3 Axle

- 4 Rotor
- 5 Rotor Drive Chains
- 6 Shear Disc

Cat powershift transmission. A Cat powershift transmission drives the rotor and is sized to handle tough cutting and deep mixing.

Heavy-duty gear reducers. Gear reducers with four planetary carriers provide excellent rotor drive reliability.

Rotor drive. Rugged drive chains provide efficient, continuous power to the rotor. Single strand heavy-duty chain resists breakage. High capacity rotor drive shafts and maintenance-free universal joints.

Three rotor speeds. Three rotor speed selection provides maximum performance in a variety of materials and cutting depths. First speed is used primarily for pulverizing the material. Second and third rotor speeds can be used as blending or mixing passes.

Heavy-duty shear disc or optional torque limiter. Protects rotor drive components from torsional stress and shock loads.

Mixing Chamber

Mixing chamber is a heavy-duty hood with large volume to handle deep mixing. Ensures depth control, proper sizing and thorough blending of reclaimed materials.

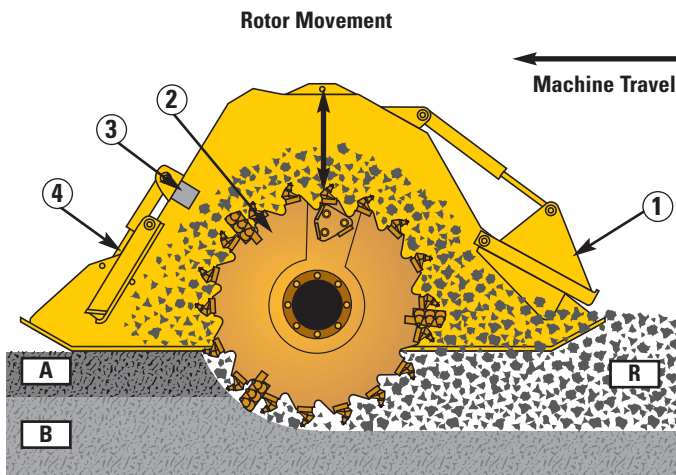

- | | |
|-----------------------------|--------------------------------------|
| A Asphalt | 1 Fully Adjustable Rear Door |
| B Base | 2 Universal Rotor (shown) |
| R Reclaimed Material | 3 Breaker Bars (if equipped) |
| | 4 Fully Adjustable Front Door |

Optimum material mixing. The mixing chamber allows the rotor to move independently so that the capacity of the chamber actually increases in deeper cuts to allow better material mixing.

Mid-machine rotor. Total machine weight on rotor helps keep rotor steady in the cut for uniform depth control.

Increased machine efficiency. Bi-directional mixing capability increases machine efficiency.

Uniform material sizing. Large heavy-duty breaker bars help achieve uniform sizing.

Hydraulically adjustable rear door. Provides optimum control of gradation and material uniformity.

Hydraulically adjustable front door. Allows more precise sizing control when operating in the reverse direction.

Quick tool replacement. Side access doors enable quick and simple replacement of cutting tools on rotor ends.

Hydraulic Front Door

Heavy-duty front door is ideal for peak efficiency on soil stabilization, bio-remediation or mixing passes on asphalt reclamation.



Hydraulically operated front door. Allows the operator to control the opening of the front door from the operator's station.

Precise control. Dual hydraulic cylinders offer increased lifting force and precise control of the front door. The front door raises parallel to the cutting surface to prevent the door from plowing material in harsh soil stabilization conditions.

Increased machine versatility. Forward or reverse operation increases machine versatility in soil stabilization.

Visual site gauge. The visual site gauge on rotor hood displays door position and allows the operator to precisely control the opening of the front door.

Rotor Selection

*Choice of two rotor designs for different applications and depth specifications.
Tools are mounted in drive-in, knock-out holders for quick and easy replacement.*



Triple-tree tool placement.

Universal Rotor. Designed primarily for use in asphalt reclamation.

200 point-attack carbide-tipped tools. Tools are mounted in drive-in, knock-out bolt-on tool holders and arranged in a chevron pattern for maximum breakout force.

Breakaway design tool holders. Allow for fast replacement without welding.

Kicker paddles placed on every stand-off. Improves mixing in soil stabilization and provides more efficient material movement in full depth reclamation.

Triple-tree tool placement. Tool placement on rotor ends cleans up loose material and reduces wear on drum when maneuvering in the cut.

Maximum depth is 457 mm.

Combination Rotor. Designed primarily for use in soil stabilization with secondary application in light cuts of asphalt reclamation.

114 point-attack carbide-tipped tools. Tools are mounted in drive-in, knock-out breakaway bolt-on tool holders.

Versatile applications. Intended for applications where material gradation is of less importance and where higher working speeds are desired.

Replaceable end rings. Rotor mandrel are protected from wear. Rings are hard-faced for extended service.

Maximum depth is 508 mm.



Serviceability

Less time on maintenance means more time on the job.



Large one-piece fiberglass hood tilts forward for exceptional access to the engine and cooling package. Daily service points are accessible from ground level and are grouped on one side of the engine. Lower side panels open wide for even greater access.

Cooling package. A multi-row modular design, stacked in series provides easy access for cleaning and service. A modular stacked cooling system provides more efficient cooling of individual systems and makes replacement and routine cleaning easier. Electronically controlled on-demand variable speed cooling fan provides the lowest overall noise levels and high ambient operation capability.

Hydraulic rotor hood tilt rotates hood forward for convenient access to rotor for inspection and tool maintenance.

Hinged service doors open wide on sides of engine, rotor hood and on top deck for access to power train and rotor drive components.



Self-lubricating rotor drive chains in sealed chain cases partially filled with oil.

Electronic Control Module (ECM). ECM monitors machine systems and provides self-diagnostics for operator or service personnel.

Warnings: Three warning levels alert operator to conditions on the machine that require attention. Encourages repair before major failure.

Level One – a flashing gauge indicator and a flashing alert indicator light.

Level Two – level one warning plus the warning action lamp flashing.

Level Three – level two warning plus the warning action horn sounds.

Visual indicators. Allows easy check of engine coolant, rotor axle and hydraulic oil level and air restriction indicator.

Quick-connect hydraulic test ports simplify system diagnostics.

Ecology drains provide an environmental method to drain fluids. They are included on the radiator, engine oil pan, hydraulic and fuel tank.

S•O•SSM ports allow for simple fluid collection of engine oil, engine coolant and hydraulic oil.

Secure hose routing. Polyethylene routing blocks reduce rubbing and increase service life.

Nylon braided wrap and all-weather connectors ensure electrical system integrity. Electrical wiring is colour-coded, numbered and labeled with component identifiers to simplify troubleshooting.

Maintenance-free Caterpillar batteries are mounted on the side of the machine and are accessible from ground level. Cat batteries are specifically designed for maximum cranking power and protection against vibration.

Machine is Product Link wire-ready. The Caterpillar Product Link System (CPLS) ensures maximum uptime and minimum repair costs by simplifying tracking of equipment fleets. Provides automatic machine location and hour updates. Can be obtained through your local Caterpillar dealer.

Engine

The Caterpillar® C15 engine with ACERT Technology is a six cylinder, turbocharged air-to-air after-cooled diesel engine. The engine meets European EU Stage IIIA emission regulations.

Gross Power	2000 rpm
SAE J1995	403 kW/548 hp
Rated Net Power	2000 rpm
ISO 9249	403 kW/548 hp
80/1269/EEC	403 kW/548 hp
Bore	137 mm
Stroke	171 mm
Displacement	15.1 liters

- All engine horsepower (hp) are metric including front page.
- The power ratings are tested under the reference conditions for the specific standard.
- Net power advertised is the power available at the flywheel when the engine is equipped with an alternator, air cleaner, muffler and fan at minimum speed.
- The engine provides a torque of 2356 Nm.
- Derating is not required up to an altitude of 1000 m.

Electrical

The 24-volt electrical system consists of two maintenance-free Cat batteries. Electrical wiring is colour-coded, numbered, wrapped in vinyl-coated nylon braid and labeled with component identifiers. The starting system provides 1365 cold cranking amps (cca). The system includes a 95-amp alternator.

Propel System

All-wheel-drive is standard to provide full-time four-wheel drive for increased tractive effort in all applications.

Features

- Front and rear wheels are hydrostatically driven by two dual displacement piston-type motors. A separate variable displacement, piston-type pump with electronic displacement control supplies pressurized flow. Planetary gear reduction on each front and rear wheel end.
- Drive motors have two swashplate positions allowing operation at either maximum torque for work or greater speed for moving around the job site.
- Gear selection controlled electrically by a two-position switch on the operator's console.
- Infinitely variable machine speed and direction of travel controlled by propel lever.

- Speed control dial allows the operator to set the maximum working speed so that when the propel lever is placed in the full forward position, the machine will return to the pre-set speed.
- Load sensing system, controlled by Electronic Control Module (ECM), matches propel speed to load on the rotor.
- Flow divider control valve provides equal hydraulic oil flow to each drive motor to increase tractive effort in slippery conditions. Operator can activate by a switch on the front control console.

Max. Speeds (forward and reverse):

Working	3.2 km/h
Roading	9.2 km/h

Frame

Fabricated from heavy gauge steel plates and structural steel tubing. Frame joined to rear bolster with welded-in trunion and spherical plain bearings to allow rear bolster oscillation of 15°.

Brakes

Primary Brake Features

- Closed-loop hydrostatic drive provides dynamic braking during normal operation.

Parking Brake Features

- Spring-applied/hydraulically-released multiple disc type brake mounted on each gear reducer. Secondary brakes are activated by a button on the operator's console, loss of hydraulic pressure in the brake circuit or when the engine is shut down.
- Propel pumps are destroyed when parking brake is engaged. Propel lever must be returned to neutral after brake is released before machine will propel.

Rotor Drive System

Operates direct through a Caterpillar three-speed, powershift transmission.

Features

- A choice of three rotor speeds permits working in a wide range of materials, depths and applications.
- ON/OFF switch controls clutch pack engagement in transmission. Disc-type brake on rotor driveline activates when switch is in the OFF position.
- Rotor speed selection is controlled electrically by a three-position switch on the operator's console. Speed selection can be changed during operation.
- Single strand, high strength rotor drive chains on both sides are contained in heavy-duty chain cases partially filled with oil.
- Shear disc or optional torque limiter protect rotor drive components.

Rotor drive	Chain
Transmission	Mechanical
Clutch	Hydraulic

Rotor Speeds at 2000 engine rpm

First	110 rpm
Second	152 rpm
Third	205 rpm

Rotor Specifications

Cutting width	2438 mm
Cutting depth	
Universal	457 mm
Combination	508 mm
Drum diameter	
Universal	1525 mm
Combination	1625 mm

Rotor Depth Control

Automatic rotor height and depth features electronic over hydraulic control. ECM controls two double-acting hydraulic cylinders on sides of mixing chamber. Actual rotor height and depth are displayed on the electronic control panel.

Features

- Three-position mode switch allows rotor depth to be controlled manually or automatically.
- Manual mode controls depth using the raise/lower switch. Visual depth gauge easily seen from operator's station.
- AUTOMATIC mode automatically controls rotor depth to a preset cutting depth. Setting cutting depth is easily accomplished first in manual mode by a switch on the operator's console.
- TRAVEL mode selection automatically raises rotor and hood to a preset travel height.

Steering

A hydraulic power-assist, steering system provides four steering modes: front steer only, crab steer, coordinated and rear steer only.

Features

- Two double-acting steering cylinders control the front wheels and are powered by a pressure-compensated, piston-type pump. One double-acting steering cylinder is attached to the rear bolster. Constant pressure is assured in the steering system.
- Switch on operator's side console provides rear wheel steering mode.

Steering Modes

- Front steer only – controlled by a hand metering unit, maintained by closed-loop control. The ECM automatically aligns rear wheels to the center position for straight tracking.
- Rear steer – controlled by a toggle switch, maintained by closed-loop control.
- Crab – front and rear wheels turn simultaneously in the same direction.
- Coordinated – front and rear wheels turn simultaneously in the opposite direction.
- Switch on operator's side console provides four steering modes.

Turning Radius (minimum):

Inside	3700 mm
--------	---------

Operating Dimensions

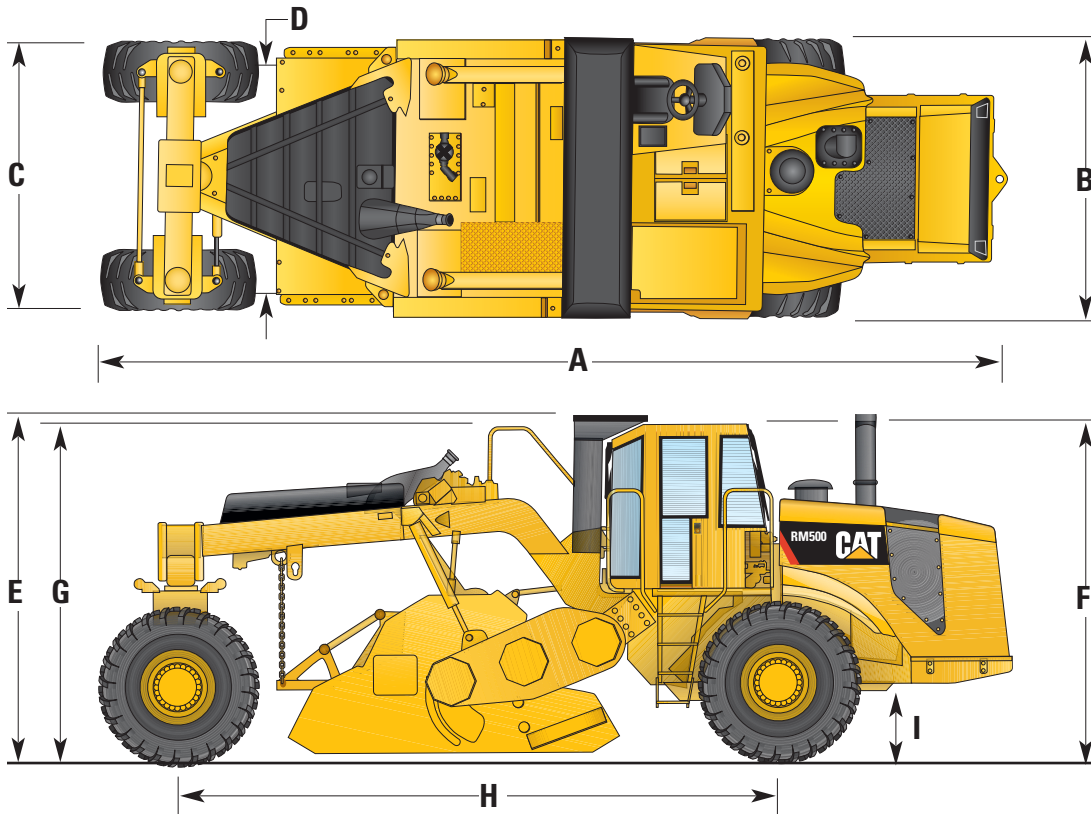

	mm		mm
A Overall length	9680	F Height at cab (if equipped)	3390
B Overall machine width	2980	G Height at handrail	3360
C Width at rear wheels	2820	H Wheelbase	6250
D Rotor hood width	2530	I Ground clearance	530
E Height at ROPS	3480	Inside turning radius	3700

Operating Weights

Weights shown are approximate and include coolant, lubricants, 50% fuel level and a 75 kg operator.

Machine Weights with sliding platform	
with universal rotor	27 430 kg
with combination rotor	26 170 kg

Optional Configurations (add to above figures)

ROPS	512 kg
FOPS	213 kg
Cab	468 kg

Tyres

Front
26.5" x 25" 20-ply lug-type R-1
3.5 bar

Rear
23.1" x 26" 16-ply lug-type R-1
2.4 bar

Service Refill Capacities

	Liters
Fuel tank (useable)	1056
Cooling system	81
Engine oil w/filter	34
Propel planetary gear reducer (each)	
Front	5
Rear	4
Hydraulic tank	233
Rotor drive axle	17
Rotor bearing reservoir	2
Chain case (each)	25.6
Rotor drive planetary gear reducer (each)	3.8
Rotor transmission	12.4

Optional Equipment

Some options listed may be an option in some areas and standard in others. Consult your dealer for specifics.

Roll Over Protective Structure (ROPS).

The two-post structure that bolts directly onto flanges welded to the mainframe. The structure meets ISO 3471. The structure can be field installed.

Falling Object Protective Structure

(FOPS). Bolts directly to the ROPS which provides Level 1 protection and also serves as a sun canopy. The structure meets ISO 3449. The structure can be field installed.

Sliding Cab. includes a rotating cloth seat, sound absorbing headliner, left and right side lockable doors, tinted glass, air conditioning, heater/defroster, dual front and rear windshield wipers and rubber floor mat. The cab is also radio-ready and includes a power converter, antenna with cable, two speakers and a headliner location for mounting.

Friction Torque Limiter. Protects rotor drive train from high torque loads in the event the rotor strikes an immovable object. The limiter slips momentarily without interrupting machine operation.

Roading Light Package. Includes two front-facing headlights, two amber running lamps, four amber turn signal/hazard lamps and a slow moving vehicle sign. Light package used for highway transport purposes only.

Warning Beacon Light. Includes an amber rotating beacon mounted on a retractable pole and mount.

Mirror Package. Includes an adjustable mirror mounted on both sides of the machine for improved visibility to the rear and along the sides of the machine.

Water Spray System. Accurately adds water to processed material. System includes a operator interface panel, hydraulic filter, EDC controlled hydraulic pump, a 379 - 1895 liters per minute vane-type centrifugal pump, in-line flow meter, spray bar with nozzles and hydraulically operated single valve spray bar shut-off.

Universal Rotor. Designed for use in asphalt reclamation and features breakaway bolt-on tool holders. Maximum cutting depth is 457 mm.

Combination Rotor. Designed primarily for use in soil stabilization with secondary application in light cuts of asphalt reclamation and features bolt-on tool holders. Maximum cutting depth is 508 mm.

Counterweight Kit. A bolt-on weight kit can be attached to the rear of the machine. The kit adds stability to the machine when operating in tough reclamation jobs exceeding 25 cm of asphalt.

RM500 Rotary Mixer

For more complete information on Cat products, dealer services, and industry solutions, visit us on the web at www.cat.com

Materials and specifications are subject to change without notice. Featured machines in photos may include additional equipment. See your Caterpillar dealer for available options.

© 2007 Caterpillar -- All rights reserved

HEHG3417-01 (07/2007) hr

CAT, CATERPILLAR, their respective logos, "Caterpillar Yellow" and the POWER EDGE trade dress as well as corporate and product identity used herein, are trademarks of Caterpillar and may not be used without permission.

CATERPILLAR[®]