



SOLAR 55v

- Operating Weight : 5,500kg (12,100 lb)
- Bucket capacity(PCSA) : 0.13~0.17m³ (0.17~0.22 cu · yd)
- Engine Power
 - DIN 6271, net 38.1 kw (51.8 PS)/2,200 rpm
 - SAE J1349, net 38.1 kw (51.1 HP)/2,200 rpm



DAEWOO
DAEWOO HEAVY INDUSTRIES &
MACHINERY LTD.



***Heavy Duty Work with Force
and Light Duty Work with more
Precision.***



Convenient and Comfortable Operation!

This standard-duty machine, offers a spacious operating area that is only found in medium and heavy-duty machines. The working controls in the cabin are ergonomically designed to ensure convenience and comfort for the operator. Resulting in operator comfort and convenient operation.



Comfortable Operating Area

The internal operating controls are arranged in a convenient and ergonomic fashion. This allows for maximized operating efficiency. A large capacity air-conditioning system has been installed for operator comfort in all seasons. The open and spacious cabin provides the operator with a wide field of view for the best possible working conditions.



Rectangular Structure Cabin

For safety purposes and to protect the operator against falling objects at various working sites, the cabin structure is designed in a rectangular shape, ensuring operator safety.

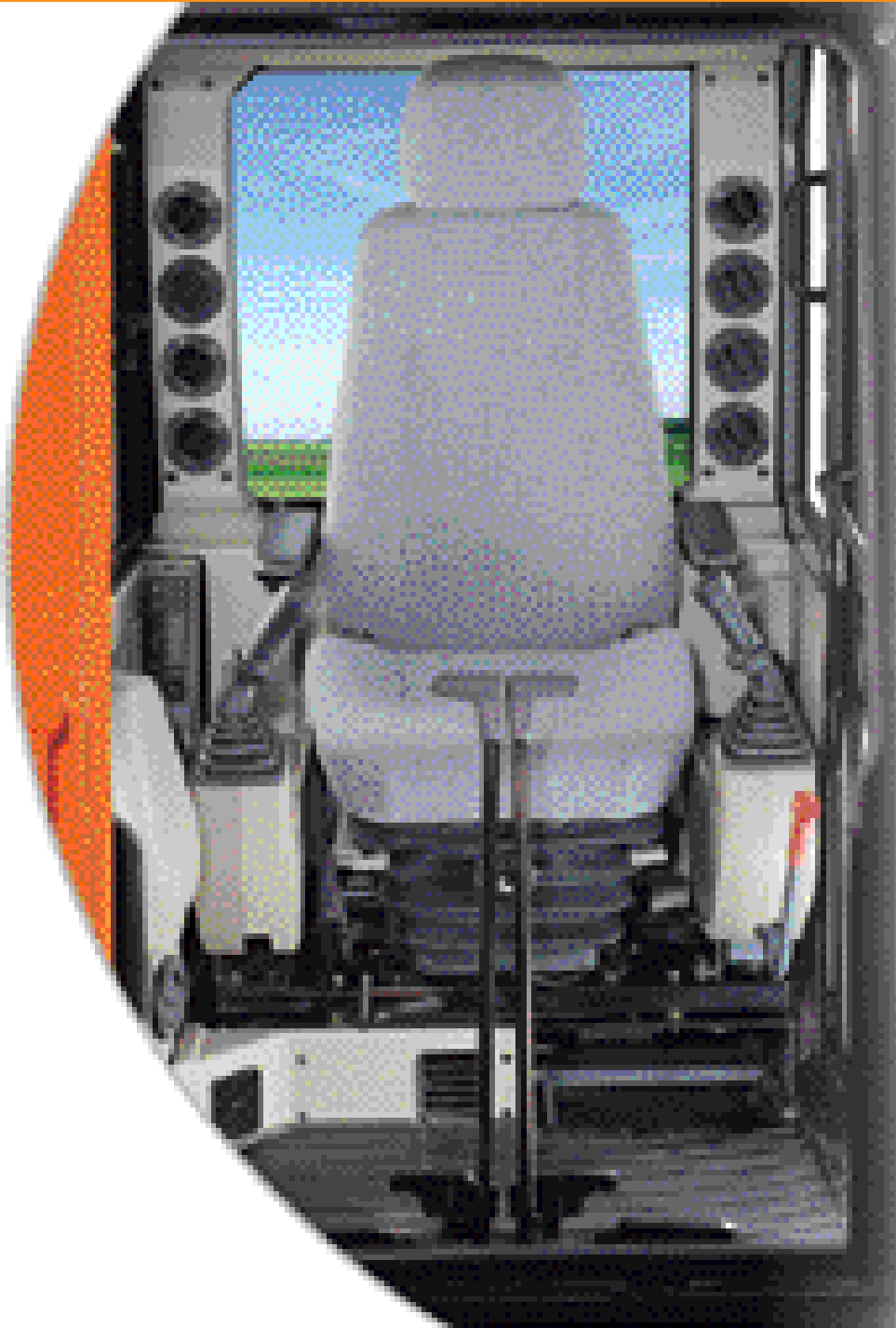



SOLAR SSV

- Vents are located in the left and right side of the rear sections.

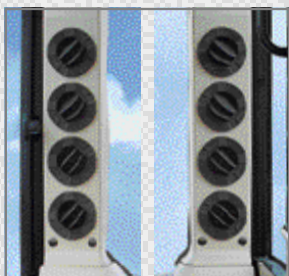

High-Output Air-Conditioner and Defroster

The air-conditioner capacity has been greatly improved and the vents have been installed at both the front and rear of the operator's seat to maximize air-conditioning efficiency. A defroster has been installed to prevent the front windshield from becoming frosted in the cold season resulting in safer operation.



Left and Right Control Stands



- Front Defroster and Lower Vent

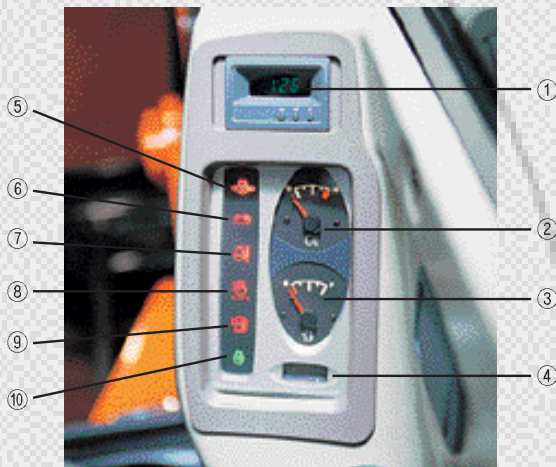

Fixed-Type Instrument Panel

Compact and elegantly designed central instrument panel makes it easy to check for various implements.

Gauges

- ① Digital Clock
- ② Engine Gauge
- ③ Fuel Gauge
- ④ Hour Meter
- ⑤ Engine Oil Pressure Warning Pilot
- ⑥ Charging Warning Pilot
- ⑦ Engine Coolant Temperature Warning Pilot
- ⑧ Clogging Air Cleaner Filter Warning Pilot
- ⑨ Fuel Warning Pilot
- ⑩ Glow Plug Pilot



Control Levers and Switches

Hydraulic joystick type lever is adopted for convenient control, and ensures precise control and excellent maneuverability. Various switches are centrally arranged to the right side of the seat for improved accessibility.

Various Convenience Devices



- Flexible Antenna



- High-end Car Stereo



- Footwear Storage Box



- Handle Release Device



- Foot Rest/Travel Pedal



- Cup Holder

Best Performance Ensured at Any Work

SOLAR 55-V plus ensures best performance with powerful excavating force and high-tech hydraulic system for better operation efficiency at any work site! Excellent performance is its basic feature! Its excellent performance with safety and convenience taken into account will help safe and convenient operation.



Powerful Excavating Force

Powerful excavating force of 3.74 tons from the 51.1HP (SAE J1349, net) engine achieves excellent performance quickly within a short time under any working conditions. In addition, a rpm controlling lever is installed on the left control lever in the cabin to make it easy to control working speed.

Composite Operation Capability Improved

Maximum combined operation capability is guaranteed by a sophisticated engine and hydraulic control system. This system allows the engine and hydraulic system to be controlled to fit various working environments such as excavating or lifting operations requiring high pressure and large hydraulic flow or grading operations requiring low pressure and small hydraulic flow rate.



Breaker-Dedicated Line Installed

The hydraulic pipes have been installed up to the front end of the arm as standard equipment, for easy installation of the hydraulic breaker. A lock device is mounted on the end of the hydraulic line to prevent leakage of hydraulic oil when connecting the breaker.



RPM control lever



Site!



SOLAR 55V

Highest Dump Height

The maximum dump height of 4,048mm is the highest among the same-grade machines and enables easy loading operation onto a 15-ton dump truck.



Bucket End and Dozer Blade Arrangement

The bucket end is designed to reach the dozer blade when the arm is folded. This feature improves efficiency in grading operation as well as stone lifting operation.



Low-Noise High-Power Engine

The 51.1HP(SAE J1349, net) engine produces outstanding power and is known for its durability. This results in excellent operation in high-load operations. In addition, it features a low noise and low emissions suitable for operation in noise sensitive areas and at night.



Large-Capacity Fuel Tank

This machine is equipped with a large-capacity fuel tank (115 liter) enabling continuous operation for two days before refueling. The fuel port has been raised in height to prevent oil leak when operating on a slope.



Large-capacity Dozer Blade

This machine is equipped with a large-capacity dozer blade (350 x 1,880 mm) ensuring excellent earth-moving operation. Its powerful dozer blade force can be used efficiently for operations on a slope.



Ground Clearance

The ground clearance has been raised to 350mm to reduce possible damage to the bottom when traveling on a rough road or logging operation.



Dozer Blade Control Lever

The dozer blade control lever is positioned above the right-hand control stand to secure easy and convenient access.

Quick and Easy Maintenance of Optimal

Sturdy SOLAR 55-V Plus!

Special and scrupulous care has been given to even unseen features for trouble free operation and easy maintenance.



Fan Belt Easy Tension Adjustment and Replacement

The spacious area around the fan belt enables easy tension adjustment and replacement. The mounted B-type belt has a greatly extended replacement interval.



Radiator

The large-capacity radiator provides excellent performance in severe and continuous operations. The assemble dust net on oil-cooler front side prevents overheating from filth.



Dual-Filter Air Cleaner

The high-performance dual-filter air cleaner eliminates dust from entering the engine. The cover is a one-touch open/close type allowing easy maintenance.

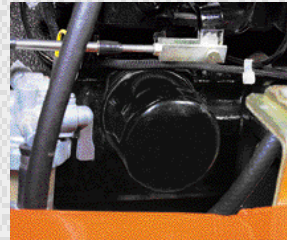

Engine Oil Filter

The engine oil filter is attached to the engine body and extends out for easy maintenance.



Working Condition!



SOLAR 55V

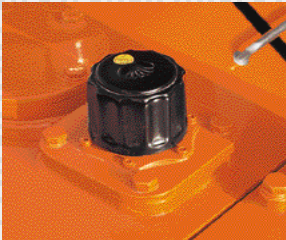

Air Breather

The mounted large-capacity air breather prevents possible damage to the pump from cavitation.



Large-capacity Free Cleaner

The mounted large-capacity free cleaner helps minimize air load pressure to heighten engine efficiency.

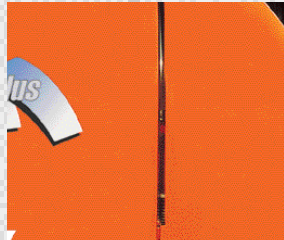

Fuel Level Gauge

The fuel level gauge has been relocated to the lower section and makes it easy to check the remaining fuel level.



Auto Fuel Dispense Pump

To reduce inconvenience in dispensing fuel at the work site, an auto fuel dispense pump has been installed.

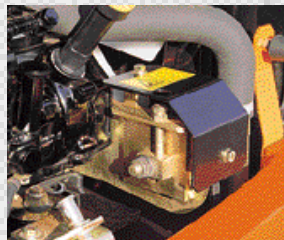
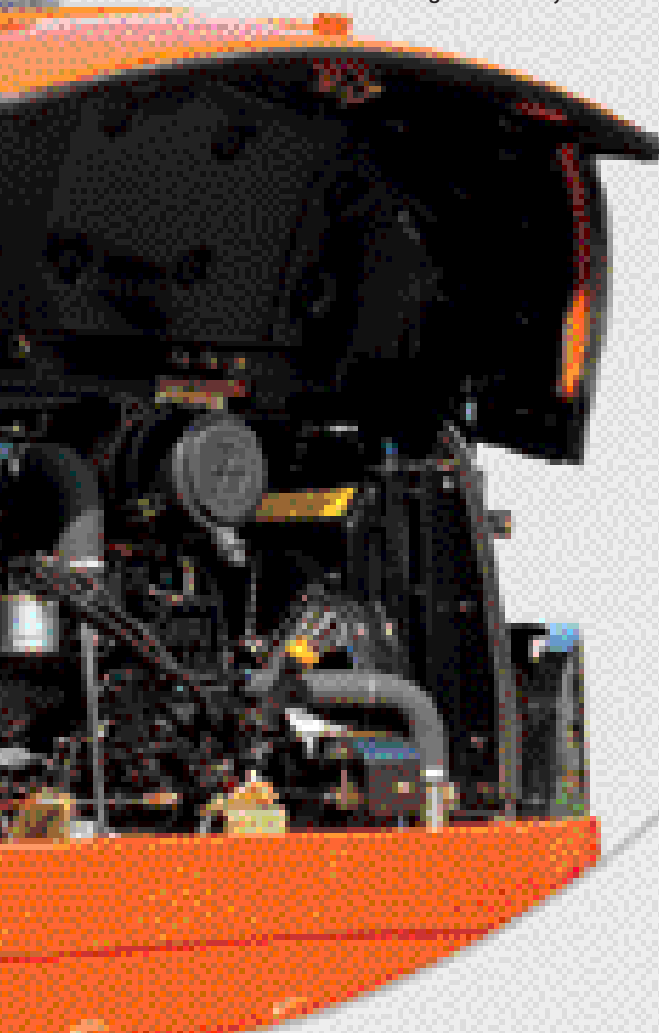

Air-Conditioner Belt

Idle pulley is mounted so that it is easy to adjust belt tension and replace the belt.



Bonnet Protecting Cover

An over-sized protective cover is installed on both lower sides of the counterweight to prevent possible damage to the bonnet when operating in a mountainous region or any place having many obstacles. Also, a net protecting the engine compartment prevents entry of foreign objects.



Prefabricated Track Guard

The track guard, which protects the vital track components is a prefabricated component and allows for easy replacement.



Full Opening Hood

Provides easy access for maintenance checks.

Technical Data

Engine

Model	YANMAR 4TNV94L-XDB
Type	Water-cooled, 4-cycle, direct injection .
Aspiration	Natural
No. of cylinders	4
Rated flywheel horse power	
DIN 6271, gross	39.7 KW (54 PS)
DIN 6271, net	38.1 KW (51.8 PS)
	at 2,200 rpm
SAE J1995, gross	39.7 KW (53.2 HP)
SAE J1349, net	38.1 KW (51.1 HP)
	at 2,200 rpm
Displacement	3,045cc (168.8 cu.in)
Maximum torque	20 kgf.m (196 Nm, 144 lbf.ft) @ 1,400 rpm
Bore and stroke	94 mm × 110 mm (3.7" × 4.3")
Starting system	12V electric motor
Batteries	1 × 12V × 100 AH

Hydraulic system

2 Variable displacement axial piston tandem type pumps.
2 Gear pumps and control valve (9-spool) of section block construction.
This original design enables both independent and combined operations of all function, joystick control type operations.

Main pumps		2 Variable displacement axial piston pump.
Max. oil flow	2-5.5 ℓ/min (12.1 UK gpm, 14.5 US gpm)	
Pilot pump		Gear pump
Max. oil flow	9.9 ℓ/min (2.17 UK gpm, 2.61 US gpm)	
Swing motor		
Relief valve	216 bar (3,129 psi, 220 kgf/cm ²)	
Main relief valves		
Boom/Arm/Bucket	206 bar (2,986 psi, 210 kgf/cm ²)	
Travel circuit	206 bar (2,986 psi, 210 kgf/cm ²)	

Hydraulic cylinders

High-strength piston rods and tubes are used. Cylinder cushion mechanism is provided for boom & arm cylinder to assure shock-free operation and extend life of cylinder.

Cylinders	Q'ty	Bore × Rod dia. × Stroke
Boom	1	115 × 60 × 720mm (4.52" × 2.36" × 2'4")
Arm	1	90 × 60 × 880mm (3.54" × 2.36" × 2'11")
Bucket	1	85 × 55 × 600mm (3.34" × 2.16" × 2')
Dozer	1	110 × 60 × 183mm (4.33" × 2.36" × 7.2")
Boom swing	1	110 × 55 × 558mm (4.33" × 2.16" × 1'10")

Super-structure revolving frame

A deep, full-reinforced box section. Heavy-gauge steel plates used for ruggedness.

Operator's cab

A roomy, independent, shock and noise-free operator's cab, 4 side safety glass windows give all-round visibility. Front window slides up and stores in the roof and side window can be opened for ventilation. Fully adjustable suspension seat. Air conditioner. ISO standard cab.

Noise Levels (dynamic value)

LwA External noise

Guaranteed Sound Power Level **101 dB (A)** (2000/14/EC)

Measured Sound Power Level **100 dB (A)** (2000/14/EC)

LpA Operator noise

81 dB (A) (ISO 6396)

Controls. 2 implement levers

Pilot pressure control type. Right lever is boom and bucket control, left lever for swing and arm control.

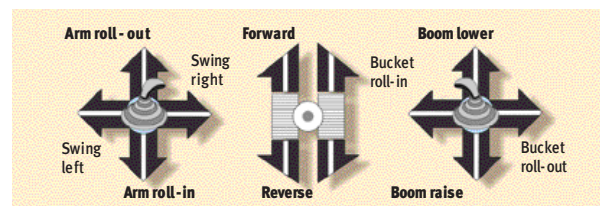

2 Travel pedals with levers

Mechanical control type. Independent drive at each track allows counter-rotation of the tracks. Levers are detachable.

Swing mechanism

High-torque, axial piston motor with planetary reduction gear bathed in oil. Swing circle is single-row, shear type ball bearing with induction-hardened internal gear. Internal gear and pinion gear immersed in lubricant. Swing parking brake is spring-set, hydraulic-released disc type.

- **Swing speed** 0 to 9.0 rpm(min⁻¹)
- **Rear swing radius** 1,650 mm(5'41")

Drive

Each track is driven by an independent, high-torque, axial piston motor through planetary reduction gears. Two levers or foot pedal control provide smooth travel or counter-rotation upon demand.

- **Travel speed (High/Low)** 3.8/2.1 km/h (2.3/1.3 mph)
- **Maximum traction force** 4,800 kgf (10,600 lbf)
- **Gradeability** 30° (58%) continuous

Undercarriage

Tractor type undercarriage. Heavy-duty track frame, all welded stress-relieved structure. Top grade materials are used for toughness. Side frames are welded, securely and rigidly, to the track frame. Lifetime-lubricated track rollers, idlers and sprockets with floating seals. Track shoes of induction-hardened rolled alloy with triple grousers. Specially heat-treated connecting pins. Hydraulic track adjusters with shock-absorbing recoil springs.

Number of rollers and shoes (each side)

- Upper rollers 1
- **(Standard shoe)**
- Lower rollers 5
- Track shoes 38
- Overall track length 2,497mm(8'2")
- Shoe width 400mm(1'4")

Brake

Two oil disc brake on final drive input shafts. Spring applied hydraulically released, when machine is stationary, brakes are set automatically, operating either travel lever disengages brakes.

Buckets

Capacity		Width		Weight	Recommendation	
PCSA, heaped	CECE, heaped	Without side cutters	With side cutters		1.6 m (5'25") Arm	3.0 m (9'84") Boom
0.126 m ³ (0.17 yd ³)	0.11 m ³ (0.14 yd ³)	300 mm (1')	362 mm (1'2")	109 kg (240 lb)	-	-
0.173 m ³ (0.22 yd ³)	0.15 m ³ (0.20 yd ³)	662 mm (2'2")	734 mm (2'5")	170 kg (375 lb)	-	-

Weight

Equipped with 3.0m(9'84") boom, 1.6m(5'25") arm, and 0.173m³(0.22yd³; PCSA heaped) bucket.

Shoe type	Shoe width	Operating weight	Ground pressure
Triple grouser	400mm (1'4")	5,500 kg (12,100 lb)	0.31 kgf/cm ² (4.41 psi)
Rubber	400mm (1'4")	5,400 kg (11,900 lb)	0.30 kgf/cm ² (4.27 psi)

Service refill capacities

	Liters	US gal	UK gal
Fuel tank	115	30.4	25.3
Cooling system	10	2.64	2.2
Lubrication	Liters	US gal	Imp gal
Engine oil	9.7	2.56	2.13
Swing drive	1.5	0.39	0.33
Final drive(each)	1.2	0.32	0.26
Hydraulic tank	80	21.1	17.6

Safety

- Safety glass windows
- Spring-set/hydraulic-released disc type travel parking brake.
- Main relief valves, make-up valves.
- Overload relief valves, hydraulic brake valves.
- Engine coolant temperature gauge.
- Monitor for before starting(Engine oil level, engine coolant level and hydraulic oil level)
- Monitor for during operation(Engine oil pressure, engine coolant temperature, alternator charge, air cleaner clogging and fuel minimum level).
- Alarm buzzer(Engine oil pressure and engine coolant temperature)
- Working lights pilot lamp
- Electric type horn
- Lever lock

Optional equipment

- | | |
|--------------------|------------------|
| Safety | Others |
| • Boom lock valve | • Two way piping |
| • Travel alarm | • Rubber track |
| • Cabin & Interior | • Breaker piping |
| • Sun visor | • Accumulator |
| | • Narrow bucket |

Lifting Capacities

Dozer Up

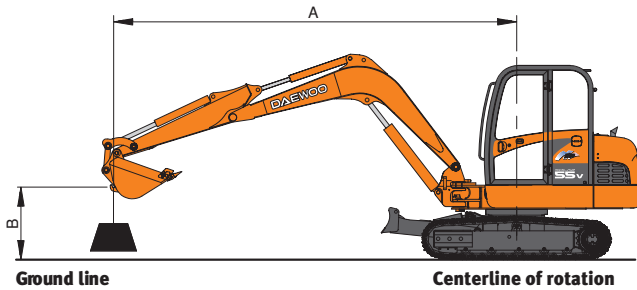

Boom : 3.0m (9'8.4")
Arm : 1.6m (5'2.5")
Bucket: PCSA 0.173m³ (CECE 0.15m³)
Shoe : 400mm (1'4")

Metric

Unit : 1,000 kg

B(m)	A(m)		2		3		4		5		Max. Reach		A(m)
	□	□□	□	□□	□	□□	□	□□	□	□□	□	□□	
4							*0.96	*0.84			*0.80	0.73	4.33
3							*1.05	0.83			0.81	0.57	4.93
2	*3.02	2.39	1.66	1.25	1.32	0.79	0.92	0.54	0.85	0.50	0.85	0.50	5.24
1	1.08	1.08	1.99	1.16	1.27	0.75	0.90	0.53	0.82	0.48	0.82	0.48	5.30
0	*1.80	*1.80	1.93	1.10	1.24	0.72	0.89	0.51	0.85	0.49	0.85	0.49	5.15
-1	*2.94	*2.10	1.91	1.09	1.23	0.71			0.96	0.55	0.96	0.55	4.73
-2	*4.05	2.14	1.93	1.11					1.25	0.73	1.25	0.73	3.97
-3	*3.06	*2.23							*2.38	1.60	*2.38	1.60	2.44

Feet

Unit : 1,000 lb

B(ft)	A(ft)		7.5'		10'		12.5'		15'		Max. Reach		A(ft)
	□	□□	□	□□	□	□□	□	□□	□	□□	□	□□	
15'							1.81	1.81			*1.81	*1.81	12'5"
12.5'							2.02	2.02			*1.75	1.52	14'7"
10'							*2.26	*1.99	*2.38	1.45	1.77	1.27	16'1"
7.5'					*3.11	2.75	*2.77	1.92	2.36	1.42	1.86	1.14	17'0"
5'	7.11	3.98	4.39	2.59	3.08	1.84	2.32	1.37	1.83	1.07	1.83	1.07	17'4"
2.5'	*4.36	*3.74	4.23	2.45	3.00	1.76	2.27	1.33	1.81	1.05	1.81	1.05	17'3"
0'	*5.24	*3.69	4.15	2.38	2.94	1.71	2.24	1.30	1.87	1.08	1.87	1.08	16'9"
-2.5'	*6.76	3.69	4.12	2.35	2.91	1.68	2.22	1.28	2.03	1.17	2.03	1.17	15'9"
-5'	*6.80	3.72	4.12	2.36	2.91	1.69			2.36	1.37	2.36	1.37	14'4"
-7.5'	*6.88	3.79	4.17	2.40					3.14	1.83	3.14	1.83	12'0"
-10'	*5.45	*3.93							*5.38	*3.87	*5.38	*3.87	7'6"

- Note
1. Ratings are based on SAE J1097
 2. Load point is the hook on the back of the bucket.
 3. " * " Rated loads are based on hydraulic capacity.
 4. Rated loads do not exceed 87% of hydraulic capacity or 75% of tipping capacity.

□ : Rating over front
 □□ : Rating over side or 360 degree
 0 : Ground

Dozer Down (Must be equipped with dozer lock valve)

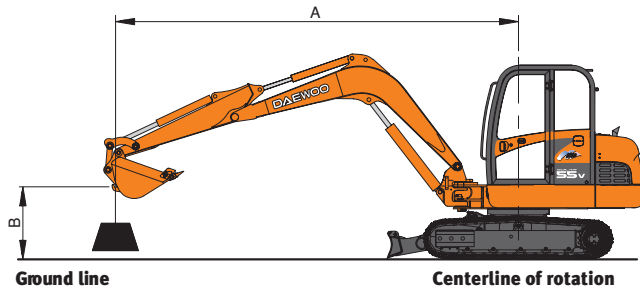

Boom : 3.0m (9'84")
Arm : 1.6m (5'25")
Bucket : PCSA 0.173m³ (CECE 0.15m³)
Shoe : 400mm (1'4")

Metric

Unit : 1,000 kg

B(m)	A(m)		2		3		4		5		Max. Reach		
	□	□	□	□	□	□	□	□	□	□	□	A (m)	
4						*0.96	0.84				*0.80	0.73	4.33
3						*1.05	0.83				*0.81	0.57	4.93
2	*3.02	2.39	*1.66	1.25	*1.33	0.79	*1.21	0.54	*0.87	0.50			5.24
1	*1.08	*1.08	*2.47	1.16	*1.67	0.75	*1.36	0.53	*0.98	0.48			5.30
0	*1.80	*1.80	*2.94	1.11	*1.94	0.72	*1.49	0.51	*1.19	0.49			5.15
-1	*2.94	2.10	*3.03	1.09	*2.03	0.71					*1.61	0.55	4.73
-2	*4.05	2.14	*2.76	1.11							1.84	0.73	3.97
-3	*3.06	2.23									*2.38	1.60	2.44

Feet

Unit : 1,000 lb

B(ft)	A(ft)		7.5'		10'		12.5'		15'		Max. Reach		
	□	□	□	□	□	□	□	□	□	□	□	A (ft)	
15'						*1.81	*1.81				*1.81	*1.81	12'5"
12.5'						*2.02	2.02				*1.75	1.52	14'7"
10'						*2.26	1.99	*2.38	1.45	*1.77	1.27		16'1"
7.5'			*3.11	2.75	*2.77	1.92	*2.62	1.42	*1.86	1.14			17'0"
5'	*7.39	3.98	*4.45	2.59	*3.44	1.84	*2.97	1.84	2.01	1.07			17'4"
2.5'	*4.36	3.74	*5.62	2.45	*4.08	1.76	*3.34	1.33	2.25	1.05			17'3"
0'	*5.24	3.69	*6.32	2.38	*4.56	1.71	*3.62	1.30	2.62	1.08			16'9"
-2.5'	*7.03	3.69	*6.54	2.35	*4.78	1.68	*3.74	1.28	3.27	1.17			15'9"
-5'	*9.34	3.72	*6.34	2.36	*4.67	1.69			3.79	1.37			14'4"
-7.5'	*8.10	3.79	*5.59	2.40					4.28	1.83			17'0"
-10'	*5.45	3.94							*5.38	3.87			7'6"

Note 1. Ratings are based on SAE J1097
 2. Load point is the hook on the back of the bucket.
 3. " * " Rated loads are based on hydraulic capacity.
 4. Rated loads do not exceed 87% of hydraulic capacity or 75% of tipping capacity.

□ : Rating over front
 □ : Rating over side or 360 degree
 0 : Ground

Dimensions & Working Ranges

Dimensions

Unit : mm(ft.in)

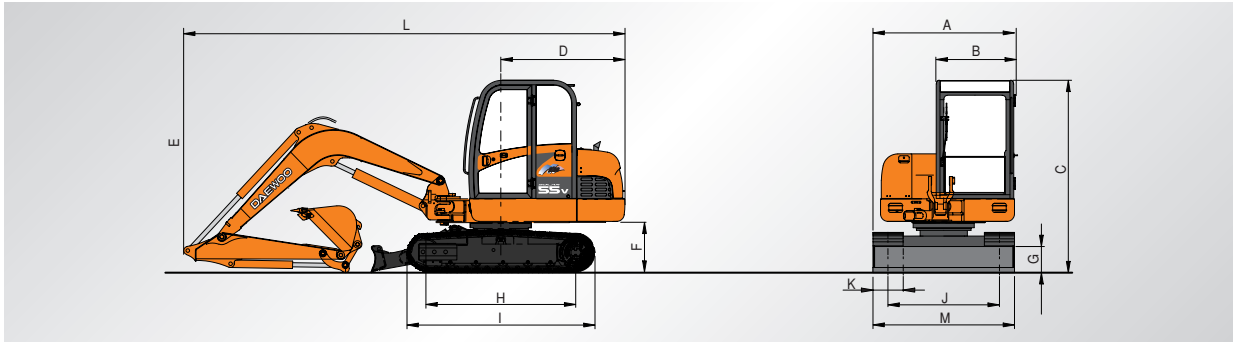

A Overall width of upper structure	1,885mm (6'2")
B Overall width of cab	1,030mm (3'5")
C Overall height of cab	2,556mm (8'5")
D Tail swing radius	1,650mm (5'5")
E Overall height	2,420mm (7'11")
F Clearance under counterweight	670mm (2'2")
G Ground clearance	350mm (1'2")
H Tumbler distance	1,990mm (6'6")
I Track length	2,497mm (8'2")
J Track gauge	1,480mm (4'10")
K Track shoe width	400mm (1'3")
L Overall length	5,850mm (19'2")
M Overall track width	1,880mm (6'2")

Working ranges

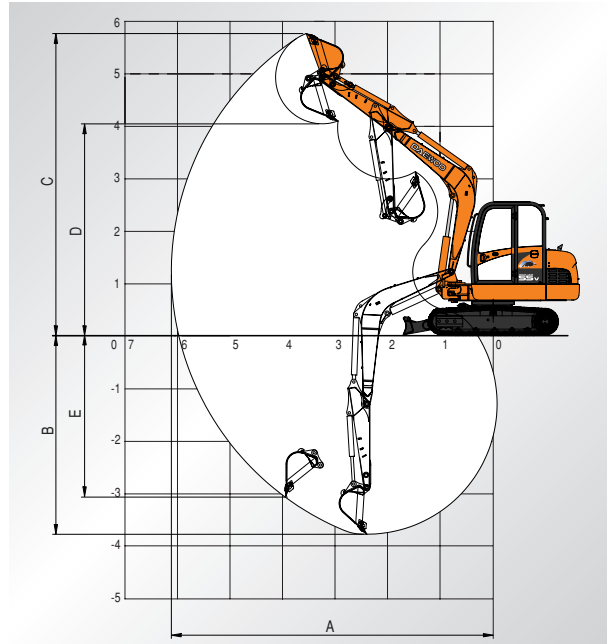

Digging forces

	SAE	ISO
Bucket digging force *	3,740 kgf 36.7 kN 8,250 lbf	4,190 kgf 41.1 kN 9,240 lbf
Arm digging force *	2,660 kgf 26.1 kN 5,860 lbf	2,740 kgf 26.9 kN 6,090 lbf

Boom length	3.0m (9'10")
Arm length	1.6m (5'3")
A. Max. digging reach	6,152mm (20'2")
B. Max. digging depth	3,796mm (12'5")
C. Max. digging height	5,774mm (18'11")
D. Max. dumping height	4,048mm (13'3")
E. Max. vertical wall digging depth	3,070mm (10'1")



*Specifications are subject to change without prior notice.

EC0037 (2003.9)

Seoul Office :

9th Floor, Daewoo Heavy Industries & Machinery Ltd. Bldg.
14-34, Youido-dong, Youngdungpo-gu,
150-010, Seoul, Korea
Mail : C. P. O Box 7955 Seoul, Korea.
Tel : (02)2167-3114 Fax : (02)785-2677
Website : www.dhiltl.co.kr

Euro Daewoo S. A :

1A, Rue Achille Degrace 7080 Frameries, Belgium
Tel : (065)61.32.30 Fax : (065)67.73.38

Euro Daewoo U. K :

Daewoo House, Unit 6.3, Nantgarw Park, Cardiff CF4 7QU, U.K
Tel : (01443)842273 Fax : (01443)841933

Euro Daewoo France :

2ema Etage, 1/3 Avenue Pavlov, Z.A.I. Des Bruyeres 78190
Trappes / France
Tel : (1)3016-2140 Fax : (1)3016-2144

Daewoo Maschinen Vertriebs GmbH :

Hans-Böckler strasse 29, D-40764, Langenfeld-Fuhrkamp, Germany
Tel : (02173)8509-20 Fax : (02173)980729

Daewoo Heavy Industries America Corporation.

2905 Shawnee Industrial Way, Suwanee, Georgia 33024, U.S.A
Tel : 770-831-2200 Fax : 770-831-0480

Daewoo Heavy Industries S. A. (PTY) Ltd.

#21 Wrench Road Corner Electron Road Isando 1600,
Johannesburg, South Africa
Tel : (11)974-2095 Fax : (11)974-2778

Daewoo Heavy Industries Yantai Co., Ltd.

No.28, Wuzhishan Road, Eco & Tech. Development Zone Yantai,
Shandong, China
Tel : 86-535-6382000 Fax : 86-535-6382004/5