

- Dimensions
- Specifications
- Working ranges main boom
- Lifting capacities main boom
- Working ranges main boom extension
- Lifting capacities main boom extension
- Technical description
- Notes to lifting capacity

Demag AC 40-1

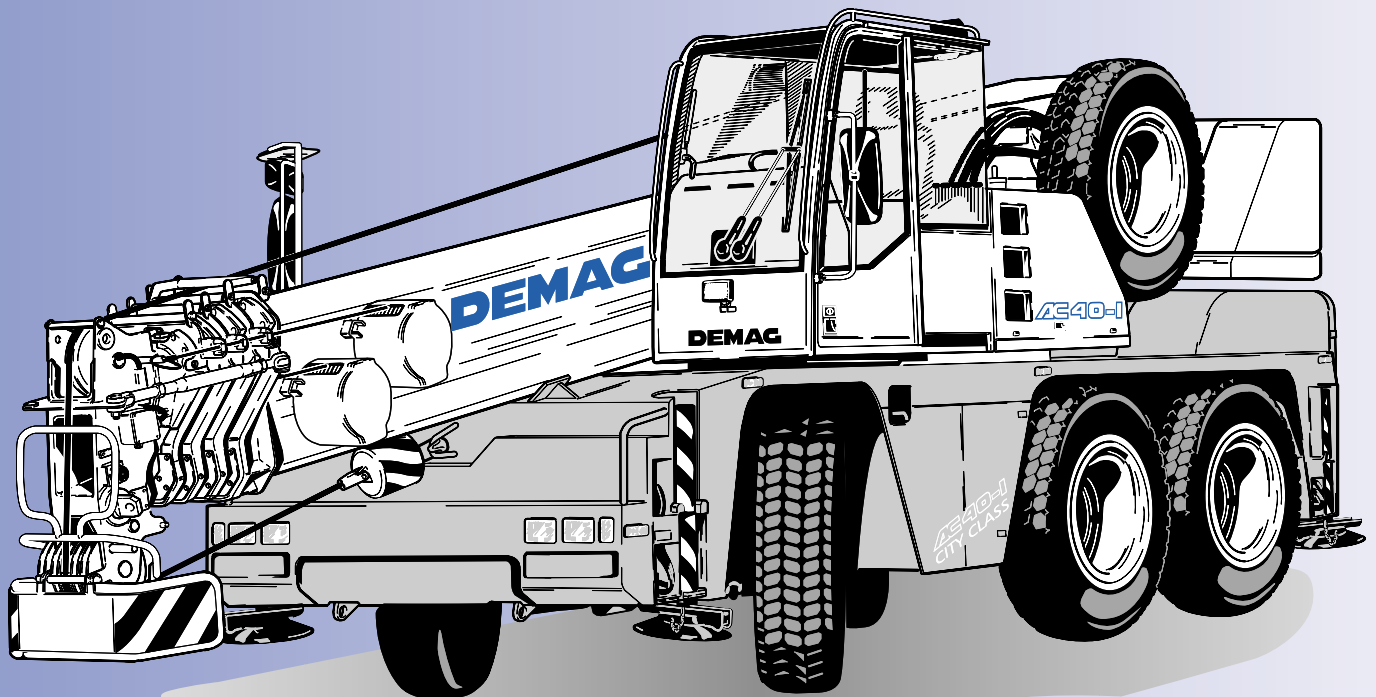

45t

MAIN MENU

Key

 Lifting capacities on outriggers 360°

 free on wheels

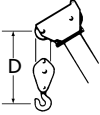
„D“ 

[MAIN MENU](#)

[CONTENTS](#)

Contents

Specifications

Dimensions 4
Specifications 6

Main boom

Working ranges 7
Lifting capacities 8

Main boom extension

Working ranges 10
Lifting capacities 11

Technical description

Carrier · Superstructure · Optional equipment 12

Dimensions

Type of tyres	Level	A	B	C	D
14.00	Road	10'5"	10'1"	1'2"	4'9"
14.00	Lowered	10'2"	9'9"	9"	4'6"
445 / 65	Road	10'1"	9'8"	8"	4'5"
445 / 65	Lowered	9'8"	9'5"	5"	4'2"

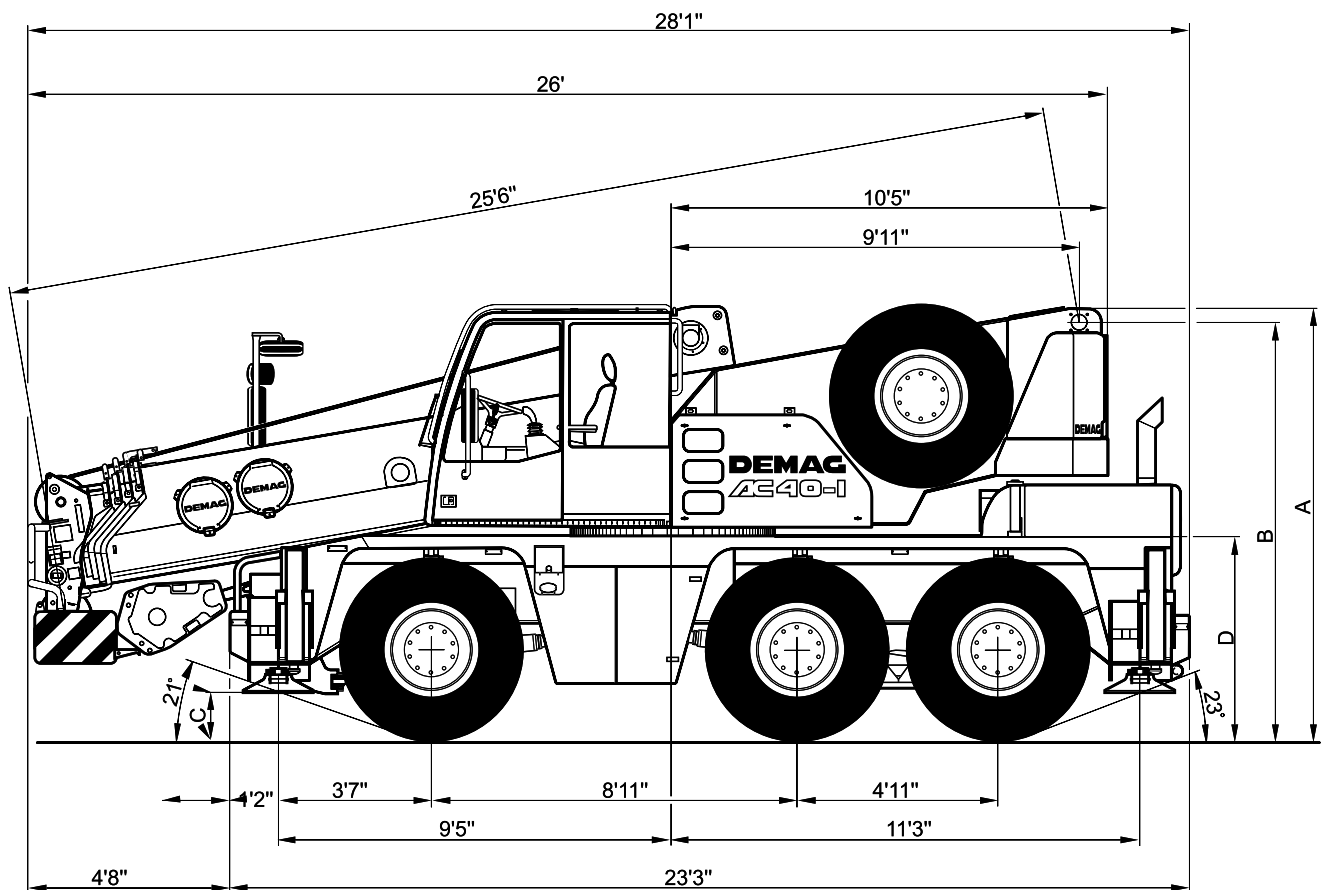

[MAIN MENU](#)

[CONTENTS](#)

Dimensions

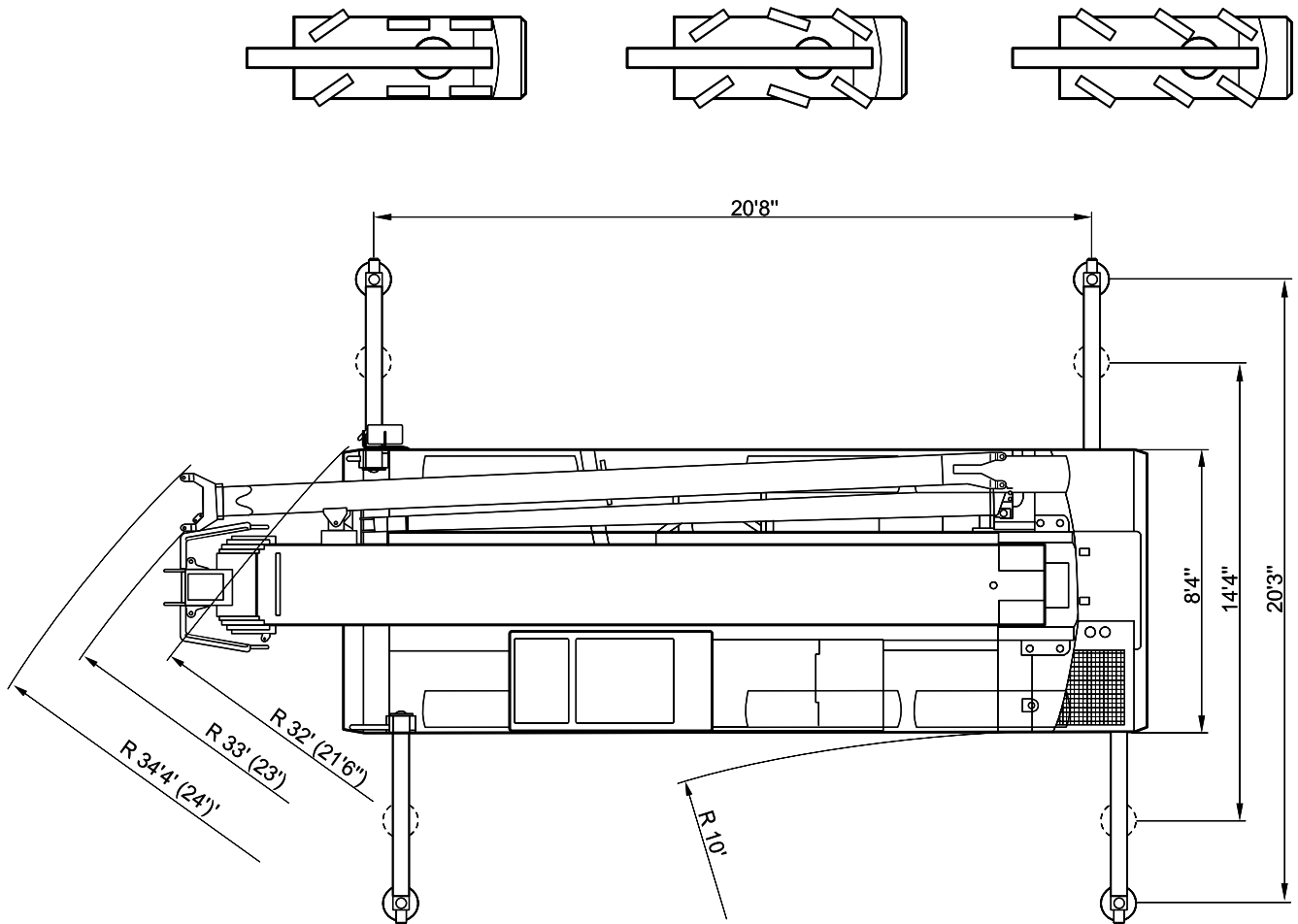

() with independent rear axle steering

[MAIN MENU](#)

[CONTENTS](#)

Specifications

Axle loads

Crane with main boom, 42.6 ft main boom extension, counterweight, tyres 445/65 R 22.5, hook block.

Axles	Axle 1	20,000 lb
Total	Axle 2+3	25,000 lb
		70,000 lb

Working speeds (infinitely variable)

Mechanisms	Normal speed	High speed	Max. permissible line pull ¹⁾	Rope length
Hoist I	197 ft/min	377 ft/min	43 kN	492.1 ft
Slewing				max. 2 1/min
Telescoping speed				25.6 – 102.3 ft: 90 s
Boom elevation				-10° – +78°: 50 s

Carrier performance

Travel speed	0 .. 50 mph ²⁾
Gradeability in travel order	> 60 %
Ground clearance	1' / 1'3" ft ²⁾

Hook block / Single line hook

Type	Possible load ¹⁾	Number of sheaves	Weight	„D“	Max. reeving	Heavy-lift attachment
63	110,000 lb	6	1058 lb	6.6 ft	10	1 add. sheave
32	66,400 lb	3	716 lb	4.3 ft	7	
16	26,500 lb	1	551 lb	3.6 ft	3	
5	8,800 lb	Single line hook	287 lb	2.6 ft	1	

Remarks

¹⁾ varies depending on national regulations

²⁾ depending on type of tyres

Lifting capacities main boom

 20'10" x 20'4" 360° 85%

Radius	Main boom							
	ft	25.6	35.1	44.6	64.0	83.0	93.2	102.3
		1,000 lb						
8	100.0*	-	-	-	-	-	-	-
10	88.0*	-	-	-	-	-	-	-
10	75.2	55.1	46.2	-	-	-	-	-
11	72.6	55.1	46.2	-	-	-	-	-
13	67.5	55.1	46.2	35.4	-	-	-	-
15	61.6	54.7	45.3	35.2	-	-	-	-
16	-	53.4	43.9	35.2	-	-	-	-
19	-	46.4	40.2	35.2	31.2	-	-	-
23	-	37.4	35.2	33.7	29.0	24.4	-	-
26	-	-	34.0	31.0	27.0	23.8	19.8	-
29	-	-	28.7	27.7	25.0	22.5	19.4	-
33	-	-	22.8	22.5	22.5	20.6	18.2	-
39	-	-	-	18.0	17.0	16.9	16.2	-
46	-	-	-	13.8	12.9	13.2	12.9	-
52	-	-	-	11.4	11.1	10.9	10.5	-
59	-	-	-	-	9.4	8.8	8.3	-
65	-	-	-	-	7.8	7.6	6.9	-
72	-	-	-	-	6.6	6.2	5.7	-
79	-	-	-	-	-	5.0	4.5	-
85	-	-	-	-	-	-	3.7	-
92	-	-	-	-	-	-	3.0	-
98	-	-	-	-	-	-	-	-
Capacities ¹⁾		44.1	30.9	19.4	9.9	5.5	4.0	2.4

 0°* 85%

Radius	Main boom			ft
	25.6	35.1	44.6	
	1,000 lb			
8	-	-	-	8
10	-	-	-	10
10	31.6	30.5	32.9	10
11	29.4	28.3	30.6	11
13	25.5	24.6	26.8	13
15	22.5	21.7	23.9	15
16	-	20.3	22.5	16
19	-	17.2	19.2	19
23	-	13.4	15.8	23
26	-	-	13.2	26
29	-	-	10.9	29
33	-	-	8.9	33
39	-	-	-	39
46	-	-	-	46
52	-	-	-	52
59	-	-	-	59
65	-	-	-	65
72	-	-	-	72
79	-	-	-	79
85	-	-	-	85
92	-	-	-	92
98	-	-	-	98
Capacities ¹⁾	17.6	8.8	6.6	Capacities ¹⁾

 20'10" x 7'8" 360° 85%

Radius	Main boom				
	ft	25.6	35.1	44.6	64.0
		1,000 lb			
13	26.5	25.1	28.2	28.7	-
15	20.9	19.8	22.6	23.3	-
16	-	17.7	20.4	21.1	-
19	-	13.4	15.7	16.4	-
23	-	9.4	11.6	12.1	-
26	-	-	9.6	10.0	-
29	-	-	8.1	8.6	-
33	-	-	6.5	6.9	-
39	-	-	-	5.1	-
46	-	-	-	3.7	-
52	-	-	-	2.9	-
59	-	-	-	-	-
Capacities ¹⁾	17.6	6.2	4.6	-	-

 360°*** 85%

Radius	Main boom			ft
	25.6	35.1	44.6	
	1,000 lb			
13	-	-	-	13
15	12.7	11.6	14.2	15
16	-	10.7	13.2	16
19	-	8.4	10.8	19
23	-	6.1	8.3	23
26	-	-	6.9	26
29	-	-	5.9	29
33	-	-	4.7	33
39	-	-	-	39
46	-	-	-	46
52	-	-	-	52
59	-	-	-	59
Capacities ¹⁾	10.6	4.2	2.9	Capacities ¹⁾

Remarks

- * 0° over rear
- ** only stationary
- ¹⁾ with horizontal boom

[MAIN MENU](#)

[CONTENTS](#)

Lifting capacities main boom

 20' 10" x 14' 5" 360°

85%

Main boom

Radius	ft	25.6	35.1	44.6	64.0	83.0	93.2	102.3	
ft					1,000 lb				ft
10		74.9	55.1	46.2	-	-	-	-	10
11		70.7	55.1	46.2	-	-	-	-	11
13		62.8	55.1	46.2	35.4	-	-	-	13
15		51.0	49.2	44.7	35.2	-	-	-	15
16		-	43.0	41.1	35.2	-	-	-	16
19		-	31.1	32.4	29.2	31.2	-	-	19
23		-	21.5	24.4	25.0	23.9	23.7	-	23
26		-	-	19.9	20.6	19.5	19.5	19.6	26
29		-	-	16.6	17.3	17.2	16.8	16.4	29
33		-	-	13.5	14.0	14.2	13.7	13.3	33
39		-	-	-	10.7	11.0	10.5	10.1	39
46		-	-	-	8.1	8.3	7.9	7.4	46
52		-	-	-	6.7	6.7	6.3	6.0	52
59		-	-	-	-	5.5	5.0	4.6	59
65		-	-	-	-	4.7	4.0	3.8	65
72		-	-	-	-	3.7	3.3	2.8	72
79		-	-	-	-	-	2.6	2.1	79
85		-	-	-	-	-	-	1.7	85
92		-	-	-	-	-	-	1.3	92
98		-	-	-	-	-	-	-	98
Capacities ¹⁾		44.1	15.4	11.5	5.5	3.3	1.8	-	Capacities ¹⁾

Remarks

1) with horizontal boom

MAIN MENU

CONTENTS

Working ranges main boom extension

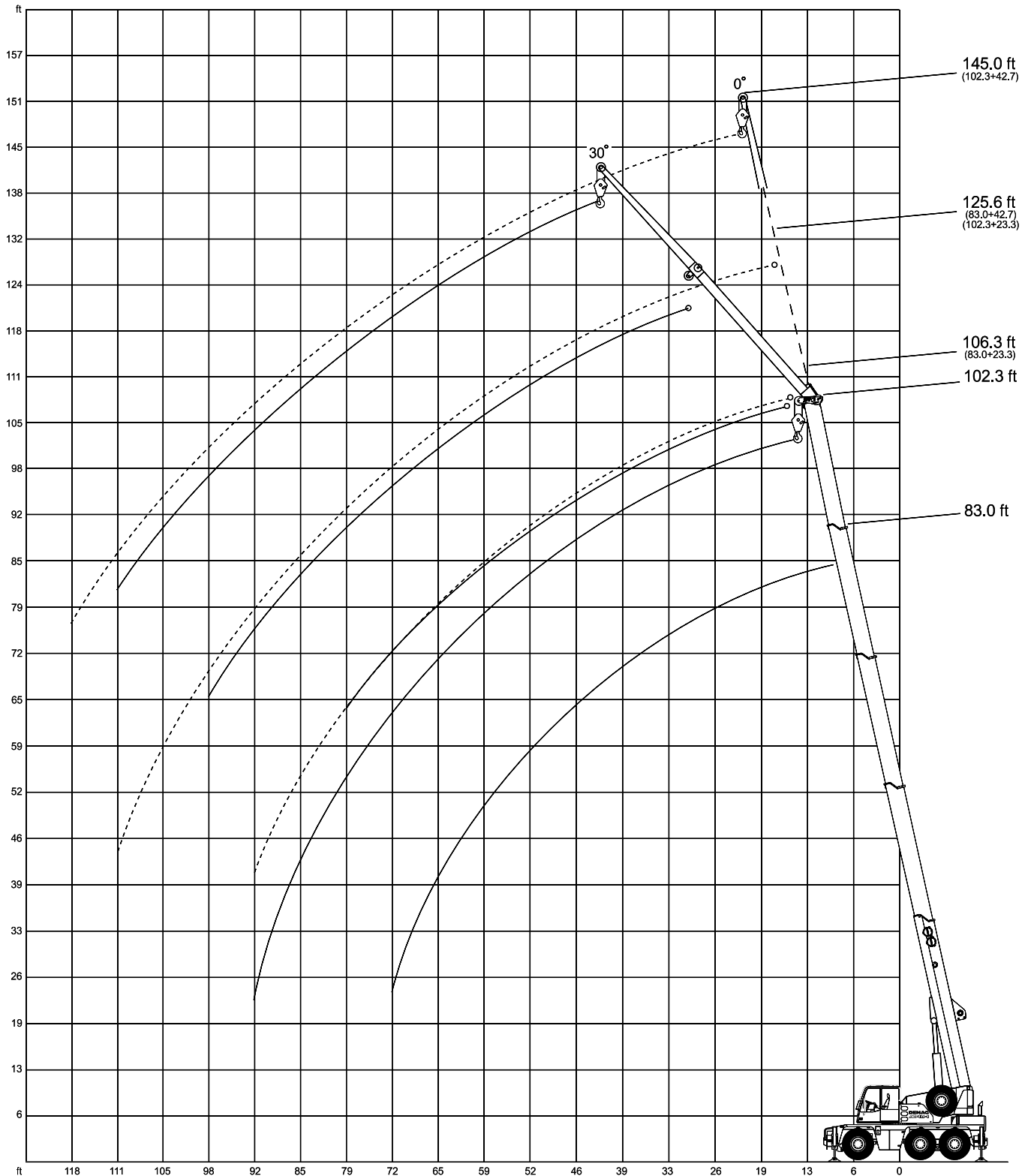

[MAIN MENU](#)

[CONTENTS](#)

Lifting capacities main boom extension

 20'10" x 20'4" 360°

85%

 20'10" x 14'5" 360°

85%

Radius ft	Extension			
	23.3 ft		42.7 ft	
	0°	30°	0°	30°
	1,000 lb			
26	14.3	-	-	-
29	13.7	-	-	-
33	12.9	9.2	7.9	-
39	11.9	8.8	7.3	-
46	10.7	8.3	6.6	-
52	9.9	8.1	6.2	4.8
59	8.8	7.7	5.7	4.6
65	7.4	7.5	5.3	4.4
72	6.2	6.4	5.0	4.1
79	5.0	5.2	4.6	4.1
85	4.2	-	4.4	3.9
92	3.5	-	3.7	3.9
98	-	-	3.3	3.5
105	-	-	2.6	-
111	-	-	2.2	-
118	-	-	-	-

Radius ft	Extension			
	23.3 ft		42.7 ft	
	0°	30°	0°	30°
	1,000 lb			
26	14.3	-	-	-
29	13.7	-	-	-
33	12.9	9.2	7.9	-
39	10.5	8.8	7.3	-
46	7.9	8.3	6.6	-
52	6.3	6.9	6.2	4.8
59	5.0	5.5	5.2	4.6
65	4.0	4.5	4.2	4.4
72	3.3	3.5	3.5	4.1
79	2.6	2.8	2.8	3.5
85	2.0	-	2.2	2.8
92	1.5	-	1.7	2.1
98	-	-	1.3	1.7
105	-	-	-	-
111	-	-	-	-
118	-	-	-	-

ft	1,000 lb			
	0°	30°	0°	30°
33	11.0	-	-	-
39	10.6	8.6	6.6	-
46	10.1	8.1	6.3	-
52	9.7	7.7	6.1	-
59	8.8	7.2	5.9	4.6
65	7.4	6.8	5.5	4.4
72	5.9	6.4	5.2	4.1
79	4.8	5.2	4.8	4.1
85	4.0	4.4	4.2	3.9
92	3.2	3.5	3.5	3.9
98	2.6	2.9	2.9	3.5
105	1.9	-	2.4	2.8
111	1.5	-	2.0	2.2
118	-	-	1.5	-

ft	1,000 lb			
	0°	30°	0°	30°
33	10.9	-	-	-
39	10.1	8.6	6.6	-
46	7.7	8.1	6.3	-
52	6.2	6.9	6.1	-
59	4.8	5.5	5.0	4.6
65	3.8	4.5	4.0	4.4
72	3.1	3.5	3.3	3.9
79	2.3	2.8	2.6	3.2
85	1.7	2.2	2.0	2.6
92	1.3	1.5	1.5	2.1
98	-	-	-	1.5
105	-	-	-	-
111	-	-	-	-
118	-	-	-	-

[MAIN MENU](#)

[CONTENTS](#)

Technical description

Carrier

Drive/steering	6 x 4 x 6
Frame	Monobox main frame with outrigger boxes integral, of high-strength fine-grain structural steel.
Outriggers	4 hydraulically telescoping outrigger beams with hydraulic jack legs.
Engine	Daimler Benz OM 906 LA „EURO II“ water-cooled 6-cylinder engine, output to DIN: 205 kW (279 hp), max. torque 1100 Nm at 1300 1/min. Fuel tank capacity: 79 gallons.
Transmission	Allison automatic transmission with torque-converter, 6 forward speeds and 1 reverse, transfer case with off-road range and longitudinal differential lock-out control.
Axles	Axle 1: with ext. planetary hubs, steering, transverse differential locks; axle 2: non-driving, steering for crab steer mode; axle 3: with ext. planetary hubs, steering for crab steer mode, transverse differential locks.
Suspension	Hydropneumatic suspension, blockable hydraulically.
Wheels and tyres	6 wheels fitted with 445/65 R 22.5 tyres.
Travel speed	50 mph.
Steering	ZF dual-circuit hydraulic steering with mech. steering end stop. 1 engine-driven master steering pump, 1 emergency steering pump. Independent rear axle steering.
Brakes	Service brake: dual-line air system. Parking brake: spring-loaded type. Sustained action brake: engine exhaust brake and constant decompression valve.
Electrical equipment	24 V system, 3-phase alternator 80 A, 2 batteries 12 V/120 Ah. Lighting in compliance with EC-directives.

Superstructure

Main boom	Boom base and 4 telescopic sections, fabricated from fine-grain structural steel, telescoping with partial load, anti-deflection Demag ovaloid design.
Counterweight	Integrated into superstructure.
Hydraulic system	Powered by carrier engine, 1 variable-displacement axial piston pump to enable 3 simultaneous, independent working movements, separate fixed-displacement pump for slew unit.
Hoist	Fixed-displacement axial-piston motor, hoist drum with planetary reduction integral and spring-applied multi-disk brake.
Slew unit	Hydraulic motor with planetary gear reducer, pedal-operated service brake and spring-applied holding brake. Slewing speed infinitely variable.
Boom elevation	1 differential cylinder with pilot-controlled lowering brake valve.
Crane cab	Spacious all-steel comfortable cab with sliding door, large folding-out windscreen, roof window with armoured glass, vertically adjustable operator's seat, controls and instrumentation for all crane movements, washer and interval control wiper for windscreen and roof window.
Safety devices	Electronic safe load indicator with graphic display and digital readout for hook load, rated load, boom length, boom angle, load radius. Integrated display to indicate the percentage of tele sequence, limit switches on hoist and lowering motions, pressure-relief and safety holding valves.

Optional equipment

Drive/steering	6 x 6 x 6.
Wheels and tyres	14.00 R 25 or 17.5 R 25.
Main boom extension	Side-folding 1 or 2-part jib, 23.3 ft or 42.7 ft. 0° and 30° offset.
Heavy-lift attachment	1 additional sheave on boom head.
Heavy-lift runner	3.9 ft long, 3-sheave with several offset positions for working inside buildings.
Searcher hook	
Air-conditioning	
Cool box	

Notes to lifting capacity

Lifting capacities do not exceed 85% of tipping load.
Weight of hook blocks and slings is part of the load, and is to be deducted from the capacity ratings.

Crane operation is permissible up to a
wind pressure of 1.25 lb/ft²
wind speed of 32 ft

Consult operation manual for further details.

Note: Data published herein is intended as a guide only and shall not be construed to warrant applicability for lifting purposes.
Crane operation is subject to the computer charts and operation manual both supplied with the crane.