

Dimensions

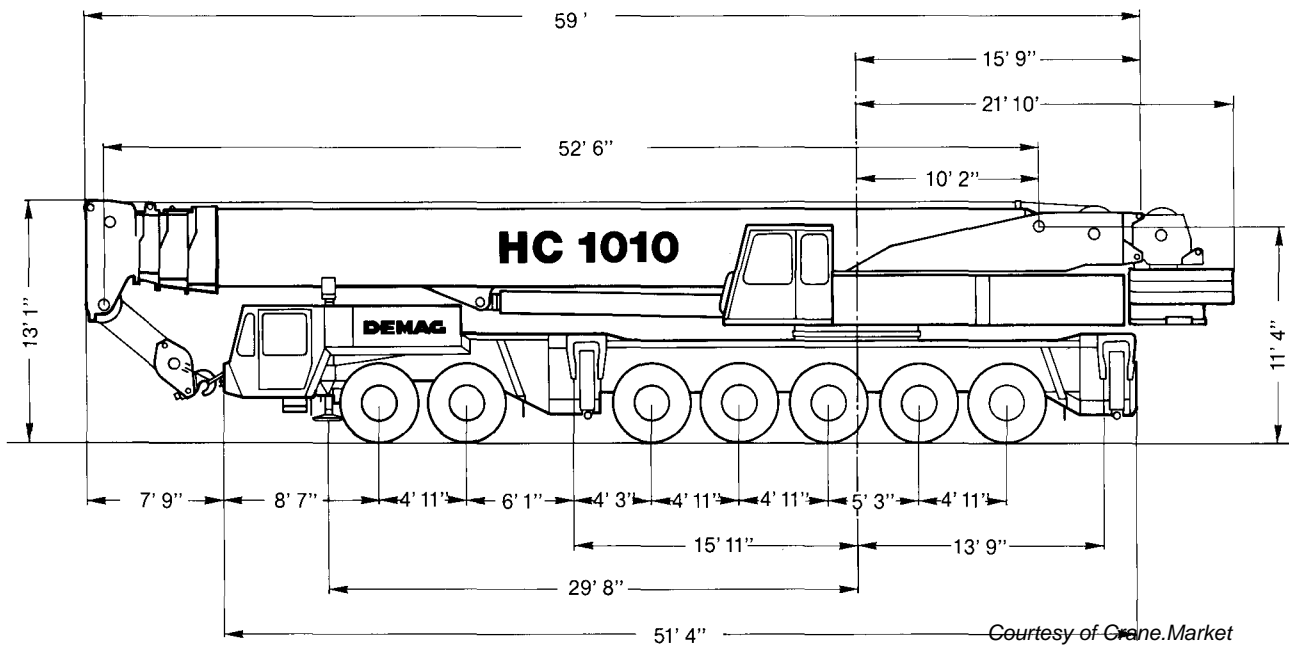

Dimensions

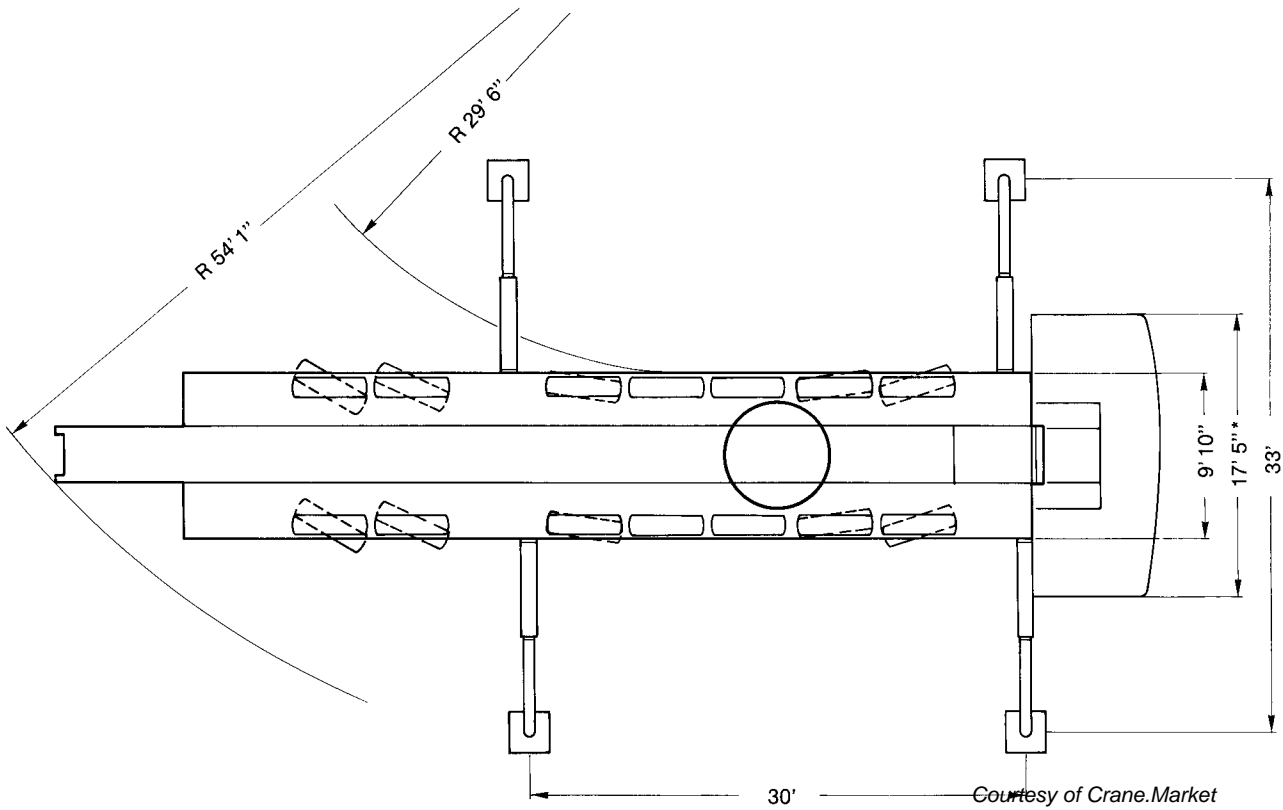

Specifications

Axle loads

Crane with main boom and hook block

Axles

7 x 26,400 lb

Total

184,800 lb

Working speeds (infinitely variable)

Units	Line speed	Max. permissible line pull ¹⁾	Length of hoist rope
Main hoist	max. 607 ft/min	111 kN	1,214 ft
Second hoist	max. 607 ft/min	111 kN	1,214 ft
Slewing		max. 1 rpm	
Telescoping speed			52 – 171 ft: 120 s
Boom elevation			-2° – +84°: 95 s

Carrier performance

Travel speed

0 .. 40 mph

Hook Block/Single Line Hook

Possible load ²⁾			Number of sheaves	Number of Lines	Weight	"D"
max.	85%	75%				
726,000 lb	726,000 lb	660,000 lb	13*	27	6,600 lb	8' 2"
484,000 lb	440,000 lb	391,000 lb	8	16	3,960 lb	8' 2"
220,000 lb	193,000 lb	171,600 lb	3	7	2,530 lb	8' 2"
88,000 lb	81,400 lb	72,600 lb	1	3	1,672 lb	8' 2"
27,500 lb	24,200 lb	22,000 lb	Single Line Hook	1	770 lb	6' 7"

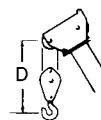

*) with heavy-lift attachment at boom head

¹⁾ varies depending on national regulations

²⁾ varies depending on line pull permissible under different national regulations

Courtesy of Crane.Market

Working range main boom

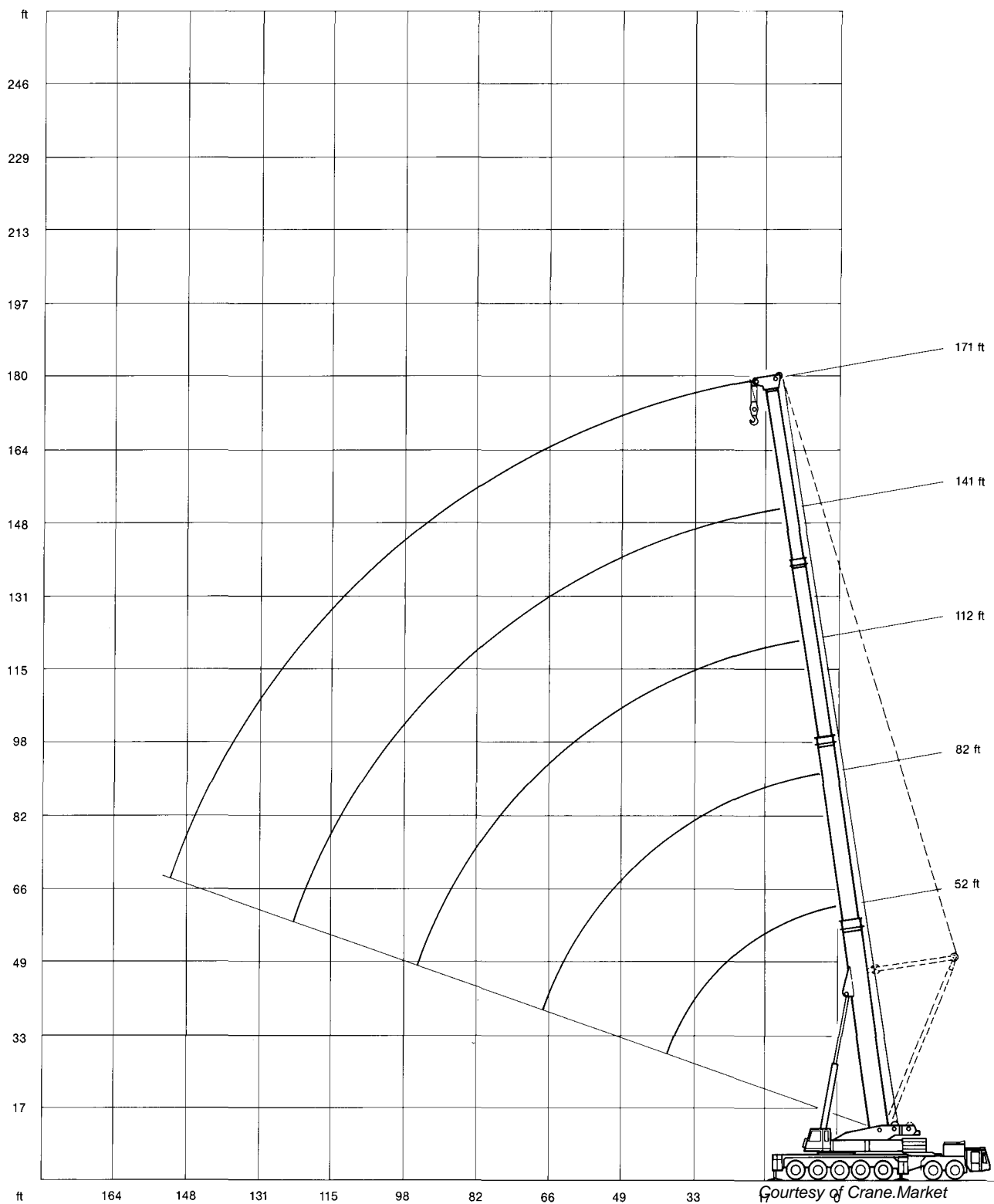

Lifting capacities main boom with Superlift in 1,000 lb

155,000 lb

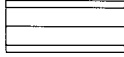

360°

85%

Radius ft	Main boom				
	52.0 Δ	82.0	112.0	141.0	171.0
			1,000 lb		
9	880.0***	-	-	-	-
9	727.0**	-	-	-	-
10	650.0**	-	-	-	-
11	606.0**	-	-	-	-
13	562.0**	-	-	-	-
15	524.0**	-	-	-	-
16	498.0**	-	-	-	-
20	407.0*	313.0*	229.0*	165.0	-
23	341.0	293.0*	212.0	159.0	-
26	291.0	271.0	202.0	147.0	-
29	264.0	251.0	194.0	136.0	-
33	244.0	235.0	185.0	126.0	90.4
39	202.0	197.0	168.0	109.0	88.6
46	-	164.0	154.0	98.1	84.7
52	-	142.0	141.0	87.0	79.3
59	-	124.0	124.0	78.2	73.6
66	-	106.9	106.0	70.5	67.2
72	-	-	91.5	65.7	62.3
79	-	-	81.5	60.4	57.3
85	-	-	71.6	56.4	53.3
92	-	-	62.8	50.7	48.5
98	-	-	56.2	47.4	46.3
105	-	-	-	44.1	43.0
112	-	-	-	42.3	40.7
118	-	-	-	39.6	38.5
125	-	-	-	37.4	35.2
131	-	-	-	-	33.0
138	-	-	-	-	30.8
144	-	-	-	-	28.6
151	-	-	-	-	26.4

Δ without SL-suspension

*** 880,000 lb at 9' radius represents max. static test load only

** only over rear or 90° over side (heavy-lift attachment)

* with heavy-lift attachment

Courtesy of Crane.Market

Lifting capacities main boom with Superlift in 1,000 lb

141,000 lb

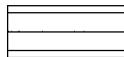

360°

85%

Radius	Main boom				
	52.0 Δ	82.0	112.0	141.0	171.0
ft	1,000 lb				
9	727.0**	-	-	-	-
11	595.0**	-	-	-	-
13	562.0**	-	-	-	-
15	524.0**	-	-	-	-
16	498.0**	-	-	-	-
20	407.0*	313.0*	229.0*	165.0	-
23	341.0	293.0*	212.0	159.0	-
26	291.0	271.0	202.0	147.0	-
29	262.0	251.0	194.0	136.0	-
33	231.0	229.0	185.0	126.0	90.4
39	<u>187.0</u>	184.0	168.0	109.0	88.6
46	-	152.0	154.0	98.1	84.7
52	-	129.0	133.0	87.0	79.3
59	-	<u>112.0</u>	<u>114.0</u>	78.2	73.6
66	-	93.9	98.3	70.5	67.2
72	-	-	84.6	65.7	62.3
79	-	-	73.6	60.4	57.3
85	-	-	64.5	56.4	53.3
92	-	-	57.3	50.7	48.5
98	-	-	51.1	47.4	46.3
105	-	-	-	<u>44.0</u>	42.9
112	-	-	-	41.2	<u>40.7</u>
118	-	-	-	37.2	37.2
125	-	-	-	33.5	33.5
131	-	-	-	-	29.9
138	-	-	-	-	26.8
144	-	-	-	-	24.4
151	-	-	-	-	22.0

Δ without SL-suspension

** only over rear or 90° over side (heavy-lift attachment)

* with heavy-lift attachment

Courtesy of Crane.Market

Lifting capacities main boom with Superlift in 1,000 lb

110,000 lb

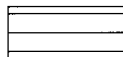

360°

85%

Radius ft	Main boom				
	52.0 Δ	82.0	112.0	141.0	171.0
ft	1,000 lb				
9	727.0**	-	-	-	-
11	595.0**	-	-	-	-
13	549.0**	-	-	-	-
15	511.0**	-	-	-	-
16	487.0**	-	-	-	-
20	394.0*	313.0*	229.0*	165.0	-
23	330.0	293.0*	212.0	159.0	-
26	282.0	271.0	202.0	147.0	-
29	247.0	244.0	194.0	136.0	-
33	218.0	217.0	185.0	126.0	90.4
39	176.0	160.0	168.0	109.0	88.6
46	-	142.0	146.0	98.1	84.7
52	-	114.0	119.0	87.0	79.3
59	-	94.1	99.7	78.2	73.6
66	-	78.9	83.3	70.5	67.2
72	-	-	71.2	65.7	62.3
79	-	-	61.7	60.4	57.3
85	-	-	53.8	54.2	53.3
92	-	-	47.4	47.6	47.8
98	-	-	42.1	42.1	42.3
105	-	-	-	37.4	37.6
112	-	-	-	33.2	33.5
118	-	-	-	29.7	29.9
125	-	-	-	26.6	26.6
131	-	-	-	-	23.5
138	-	-	-	-	20.9
144	-	-	-	-	17.4
151	-	-	-	-	16.3

Δ without SL-suspension

** only over rear or 90° over side (heavy-lift attachment)

* with heavy-lift attachment

Courtesy of Crane.Market

Lifting capacities main boom with Superlift in 1,000 lb

80,000 lb

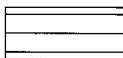

360°

85%

Radius	Main boom				
	52.0 Δ	82.0	112.0	141.0	171.0
ft	1,000 lb				
11	573.0**	-	-	-	-
13	548.0**	-	-	-	-
15	511.0**	-	-	-	-
16	451.0*	-	-	-	-
20	363.0	313.0*	229.0*	165.0	-
23	304.0	293.0*	212.0	159.0	-
26	260.0	258.0	202.0	147.0	-
29	227.0	224.0	194.0	136.0	-
33	201.0	197.0	185.0	126.0	90.4
39	<u>162.0</u>	<u>157.0</u>	<u>162.0</u>	109.0	88.6
46	-	121.0	126.0	98.1	84.7
52	-	95.9	101.0	87.0	79.3
59	-	77.8	82.8	78.2	73.6
66	-	64.5	69.2	69.2	<u>67.2</u>
72	-	-	58.6	58.6	58.6
79	-	-	50.4	50.4	50.4
85	-	-	43.4	43.4	43.4
92	-	-	37.9	37.9	37.9
98	-	-	33.0	33.0	33.0
105	-	-	-	28.6	28.6
112	-	-	-	24.9	24.9
118	-	-	-	21.6	21.6
125	-	-	-	18.9	18.9
131	-	-	-	-	16.0
138	-	-	-	-	13.8
144	-	-	-	-	11.7
151	-	-	-	-	9.7

Δ without SL-suspension

** only over rear or 90° over side (heavy-lift attachment)

* special equipment required

Courtesy of Crane.Market

440 Ton Telescopic Truck Crane

Demag HC 1010

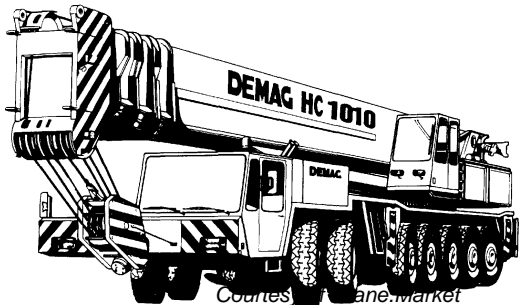

Courtesy, www.cranemarket.com

Lifting capacities main boom in 1,000 lb

110,000 lb

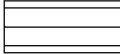

360°

85%

Radius ft	Main boom				
	52.0	82.0 ¹⁾	112.0 ¹⁾	141.0 ¹⁾	171.0 ²⁾
ft	1,000 lb				
9	727.0**	-	-	-	-
11	639.0**	-	-	-	-
13	595.0**	363.0*	-	-	-
15	549.0**	350.0*	-	-	-
16	487.0**	335.0*	238.0*	-	-
20	394.0*	306.0	222.0*	150.0	-
23	330.0	284.0	205.0	143.0	84.8
26	282.0	262.0	189.0	133.0	84.8
29	247.0	247.0	174.0	123.0	84.8
33	218.0	216.0	159.0	114.0	84.8
39	176.0	174.0	140.0	99.2	82.6
46	-	143.0	121.0	88.1	74.9
52	-	117.0	108.0	78.2	67.2
59	-	95.9	97.0	69.4	60.6
66	-	81.1	84.8	61.7	55.1
72	-	-	72.7	57.3	49.6
79	-	-	63.0	51.8	45.2
85	-	-	55.3	48.5	40.7
92	-	-	48.9	43.0	37.4
98	-	-	43.4	39.6	33.0
105	-	-	-	35.2	30.8
112	-	-	-	34.1	28.6
118	-	-	-	30.4	26.4
125	-	-	-	27.5	23.1
131	-	-	-	-	20.9
138	-	-	-	-	18.7
144	-	-	-	-	15.4
151	-	-	-	-	13.2

1) only one telescope unpinned, max. load 110,000 lb
 2) only one telescope unpinned, max. load 66,000 lb
 ** only over rear or 90° over side (heavy-lift attachment)
 * with heavy-lift attachment

Lifting capacities main boom in 1,000 lb

80,000 lb

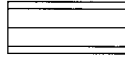

360°

85%

Radius ft	Main boom				
	52.0	82.0 ¹⁾	112.0 ¹⁾	141.0 ¹⁾	171.0 ²⁾
ft	1,000 lb				
9	727.0**	-	-	-	-
11	573.0**	-	-	-	-
13	549.0**	363.0*	-	-	-
15	511.0**	350.0*	-	-	-
16	452.0*	335.0*	238.0*	-	-
20	363.0	306.0	222.0*	150.0	-
23	304.0	284.0	205.0	143.0	84.8
26	260.0	258.0	189.0	133.0	84.8
29	229.0	225.0	174.0	123.0	84.8
33	201.0	198.0	159.0	114.0	84.8
39	<u>162.0</u>	159.0	140.0	99.2	82.6
46	-	<u>121.0</u>	<u>121.0</u>	88.1	74.9
52	-	96.1	101.0	78.2	67.2
59	-	78.7	82.9	69.4	60.6
66	-	65.4	69.4	61.7	55.1
72	-	-	59.0	<u>57.3</u>	49.6
79	-	-	50.7	50.7	45.2
85	-	-	44.0	44.0	40.7
92	-	-	38.5	38.5	<u>37.4</u>
98	-	-	33.7	33.5	33.0
105	-	-	-	29.3	29.1
112	-	-	-	25.2	25.3
118	-	-	-	22.2	22.0
125	-	-	-	19.4	19.2
131	-	-	-	-	16.7
138	-	-	-	-	14.5
144	-	-	-	-	12.5
151	-	-	-	-	10.8

1) only one telescope unpinned, max. load 110,000 lb

2) only one telescope unpinned, max. load 66,000 lb

** only over rear or 90° over side (heavy-lift attachment)

* with heavy-lift attachment

Lifting capacities main boom in 1,000 lb

49,000 lb



360°

85%

Radius ft	Main boom				
	52.0	82.0 ¹⁾	112.0 ¹⁾	141.0 ¹⁾	171.0 ²⁾
ft	1,000 lb				
11	474.0*	-	-	-	-
13	474.0*	363.0*	-	-	-
15	471.0*	350.0*	-	-	-
16	419.0*	335.0*	238.0*	-	-
20	337.0	306.0	222.0*	150.0	-
23	280.0	277.0	205.0	143.0	84.8
26	240.0	238.0	189.0	133.0	84.8
29	208.0	206.0	174.0	123.0	84.8
33	<u>184.0</u>	<u>181.0</u>	<u>159.0</u>	114.0	84.8
39	132.0	127.0	133.0	99.2	82.6
46	-	96.1	101.0	88.1	74.9
52	-	75.4	80.2	<u>78.2</u>	67.2
59	-	61.0	65.0	65.0	60.6
66	-	50.0	54.0	54.0	<u>54.0</u>
72	-	-	45.2	45.2	45.2
79	-	-	38.8	38.6	38.6
85	-	-	32.4	32.0	32.0
92	-	-	27.5	27.5	27.5
98	-	-	23.5	23.1	23.1
105	-	-	-	19.4	19.4
112	-	-	-	16.5	16.3
118	-	-	-	13.6	13.4
125	-	-	-	11.4	11.0
131	-	-	-	-	8.3
138	-	-	-	-	6.3
144	-	-	-	-	4.4
151	-	-	-	-	2.8

¹⁾ only one telescope unpinned, max. load 110,000 lb

²⁾ only one telescope unpinned, max. load 66,000 lb

* with heavy-lift attachment

Lifting capacities main boom in 1,000 lb

19,000 lb

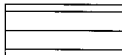

360°

85%

Radius ft	Main boom				
	52.0	82.0 ¹⁾	112.0 ¹⁾	141.0 ¹⁾	171.0 ²⁾
ft	1,000 lb				
11	474.0*	-	-	-	-
13	463.0*	363.0*	-	-	-
15	432.0*	350.0*	-	-	-
16	379.0*	335.0*	238.0*	-	-
20	306.0	302.0	222.0*	150.0	-
23	253.0	251.0	205.0	143.0	84.8
26	<u>218.0</u>	<u>215.0</u>	189.0	133.0	84.8
29	177.0	172.0	<u>174.0</u>	123.0	84.8
33	142.0	138.0	145.0	114.0	84.8
39	100.0	96.1	101.0	<u>99.2</u>	82.6
46	-	71.2	76.0	76.0	74.0
52	-	54.4	59.0	59.0	57.0
59	-	42.1	46.7	46.7	45.1
66	-	32.6	37.2	37.2	36.1
72	-	-	29.7	29.7	<u>21.1</u>
79	-	-	25.3	25.3	25.3
85	-	-	18.9	18.9	18.9
92	-	-	15.2	15.0	15.0
98	-	-	11.9	11.7	11.7
105	-	-	-	8.8	8.8
112	-	-	-	6.3	6.3
118	-	-	-	4.4	4.1

1) only one telescope unpinned, max. load 110,000 lb

2) only one telescope unpinned, max. load 66,000 lb

* with heavy-lift attachment

Lifting capacities main boom in 1,000 lb

0 lb   **360°** **85%**

Radius ft	Main boom				
	52.0	82.0 ¹⁾	112.0 ¹⁾	141.0 ¹⁾	171.0 ²⁾
ft	1,000 lb				
11	441.0*	-	-	-	-
13	425.0*	363.0*	-	-	-
15	405.0*	350.0*	-	-	-
16	359.0	335.0*	238.0*	-	-
20	289.0	286.0	222.0*	150.0	-
23	<u>240.0</u>	<u>238.0</u>	205.0	143.0	84.8
26	189.0	187.0	189.0	133.0	84.8
29	145.0	142.0	149.0	123.0	84.8
33	114.0	113.0	119.0	114.0	84.8
39	79.3	77.1	82.8	82.8	76.2
46	-	52.9	59.5	59.0	54.6
52	-	38.5	44.0	44.3	40.7
59	-	28.8	34.1	34.1	31.0
66	-	21.1	25.7	25.7	23.8
72	-	-	19.6	19.6	18.2
79	-	-	14.7	14.7	13.8
85	-	-	10.1	10.5	<u>10.1</u>
92	-	-	6.6	6.8	6.8
98	-	-	3.7	3.7	3.9

1) only one telescope unpinned, max. load 110,000 lb

2) only one telescope unpinned, max. load 66,000 lb

* with heavy-lift attachment

Notes to lifting capacity

Lifting capacities do not exceed 85% of tipping load.

Weight of hook blocks and slings is part of the load, and is to be deducted from the capacity ratings.

Crane operation is permissible up to a

wind speed of 32 ft/s

Consult operation manual for further details on wind speed.

All capacities above the parting line are based on structural competence. Capacities below the parting line are based on machine stability.

Crane operation subject to computer charts, only!

For crane operation consult operation manual first!

Courtesy of Crane.Market

Lifting capacities main boom extension with Superlift in 1,000 lb

Main boom: 171 ft

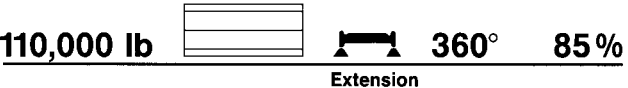

Radius ft	39 ft		66 ft	
	0°	15°	0°	15°
	1,000 lb			
39	49.6	-	26.5	-
46	49.6	36.6	25.1	-
52	48.5	34.6	24.5	19.8
59	46.9	32.6	23.3	18.0
66	45.0	31.5	22.5	18.3
72	42.5	29.7	21.6	17.6
79	40.3	28.0	20.7	17.0
85	38.3	26.6	19.8	16.1
92	35.7	25.1	19.2	15.6
98	33.0	23.8	18.5	15.2
105	31.1	22.7	17.4	14.3
112	29.3	21.3	16.7	13.9
118	27.3	20.5	15.8	13.4
125	25.3	19.2	15.4	13.0
131	22.7	18.3	14.7	12.3
138	20.0	17.0	13.9	11.9
144	18.0	15.8	13.2	11.4
151	<u>16.3</u>	15.0	12.5	11.2
157	14.8	14.1	11.9	10.5
164	12.8	13.2	11.0	10.1
177	-	<u>9.7</u>	10.3	9.4
190	-	-	9.4	8.7
203	-	-	<u>7.1</u>	<u>7.7</u>

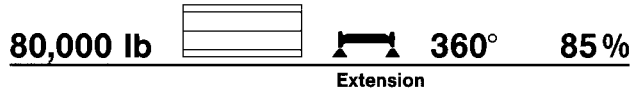



Radius ft	39 ft		66 ft	
	0°	15°	0°	15°
	1,000 lb			
39	49.6	-	26.5	-
46	49.6	36.6	25.1	-
52	48.5	34.6	24.5	19.8
59	46.9	32.6	23.3	18.0
66	45.0	31.5	22.5	18.3
72	42.5	29.7	21.6	17.6
79	40.3	28.0	20.7	17.0
85	38.3	26.6	19.8	16.1
92	35.7	25.1	19.2	15.6
98	<u>33.0</u>	23.8	18.5	15.2
105	30.0	22.7	17.4	14.3
112	26.5	21.3	16.7	13.9
118	22.7	20.5	15.8	13.4
125	20.0	19.2	15.4	13.0
131	17.0	<u>18.3</u>	14.7	12.3
138	14.5	16.1	13.9	11.9
144	12.6	13.7	13.2	11.4
151	10.1	11.4	12.5	11.2
157	8.4	9.5	<u>11.9</u>	10.5
164	6.8	7.5	10.1	<u>10.1</u>
177	-	4.2	7.0	8.4
190	-	-	4.4	5.5
203	-	-	<i>Courtesy of CraneMarket</i>	3.1

Lifting capacities main boom extension in 1,000 lb

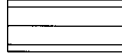

Main boom: 171 ft

110,000 lb   **360°** **85%**

Radius ft	Extension			
	39 ft		66 ft	
	0°	15°	0°	15°
	1,000 lb			
33	49.6	-	-	-
39	46.3	-	26.4	-
46	43.6	36.6	25.1	-
52	40.7	34.6	24.4	19.8
59	38.5	32.6	23.3	18.9
66	36.3	31.5	22.4	18.3
72	34.1	29.7	21.6	17.6
79	32.0	28.0	20.7	17.0
85	30.0	26.6	19.8	16.1
92	28.2	25.1	19.1	15.6
98	26.4	23.8	18.5	15.2
105	24.4	22.7	17.4	14.3
112	22.9	21.3	16.7	13.9
118	21.1	20.5	15.8	13.4
125	19.1	18.9	15.4	13.0
131	17.4	16.9	14.7	12.3
138	14.4	15.0	13.9	11.9
144	13.6	13.2	13.2	11.4
151	12.3	11.6	12.5	11.2
157	11.2	10.5	11.9	10.5
164	9.9	9.2	11.0	10.1
177	7.9	7.0	9.4	9.4
190	-	-	7.7	7.7
203	-	-	6.1	6.1

80,000 lb   **360°** **85%**

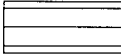
Radius ft	Extension			
	39 ft		66 ft	
	0°	15°	0°	15°
	1,000 lb			
33	49.0	-	-	-
39	46.3	-	26.4	-
46	43.6	36.6	25.1	-
52	40.7	34.6	24.4	19.8
59	38.5	32.6	23.3	18.9
66	36.3	31.5	22.4	18.3
72	34.1	29.7	21.6	17.6
79	32.0	28.0	20.7	17.0
85	30.0	26.6	19.8	16.1
92	28.2	25.1	19.1	15.6
98	26.4	23.8	18.5	15.2
105	24.4	22.7	17.4	14.3
112	22.9	21.3	16.7	13.9
118	21.1	20.5	15.8	13.4
125	19.1	18.9	15.4	13.0
131	17.4	16.9	14.7	12.3
138	15.0	15.0	13.9	11.9
144	12.8	13.2	13.2	11.4
151	10.8	11.6	12.5	11.2
157	8.8	9.7	11.2	10.5
164	7.0	7.9	10.4	10.1
177	-	4.6	7.5	8.8
190	-	-	4.6	5.7
203	-	-	2.6	3.5

49,000 lb   **360°** **85%**

Radius ft	Extension			
	39 ft		66 ft	
	0°	15°	0°	15°
	1,000 lb			
33	49.0	-	-	-
39	46.3	-	26.4	-
46	43.6	36.6	25.1	-
52	40.7	34.6	24.4	19.8
59	38.5	32.6	23.3	18.9
66	36.3	31.5	22.4	18.3
72	34.1	29.7	21.6	17.6
79	32.0	28.0	20.7	17.0
85	30.0	26.6	19.8	16.1
92	28.2	25.1	19.1	15.6
98	24.2	23.8	18.5	15.2
105	20.5	22.5	17.4	14.3
112	17.2	19.4	16.7	13.9
118	14.1	16.1	15.8	13.4
125	11.7	13.4	14.7	13.0
131	9.5	11.0	12.8	12.3
138	7.3	8.8	10.6	11.9
144	5.3	6.4	8.8	11.0
151	3.5	4.6	6.8	8.8
157	-	2.8	5.5	7.3
164	-	-	4.0	5.5
177	-	-	-	2.6

19,000 lb   **360°** **85%**

Radius ft	Extension			
	39 ft		66 ft	
	0°	15°	0°	15°
	1,000 lb			
33	49.0	-	-	-
39	46.3	-	26.4	-
46	43.6	36.6	25.1	-
52	40.7	34.6	24.4	19.8
59	38.5	32.6	23.3	18.9
66	36.1	31.5	22.4	18.3
72	29.3	29.7	21.6	17.6
79	23.8	26.8	20.7	17.0
85	19.6	22.2	19.8	16.1
92	15.8	18.3	18.0	15.6
98	12.7	15.0	15.0	15.2
105	10.1	12.1	12.3	14.3
112	7.5	9.5	10.1	13.0
118	4.8	7.0	8.3	10.8
125	2.8	4.4	6.6	8.8
131	-	2.4	4.4	7.0
138	-	-	2.6	5.0
144	-	-	-	3.3
151	-	-	-	-
157	-	-	-	-
164	-	-	-	-
177	-	-	-	-

Working range main boom extension

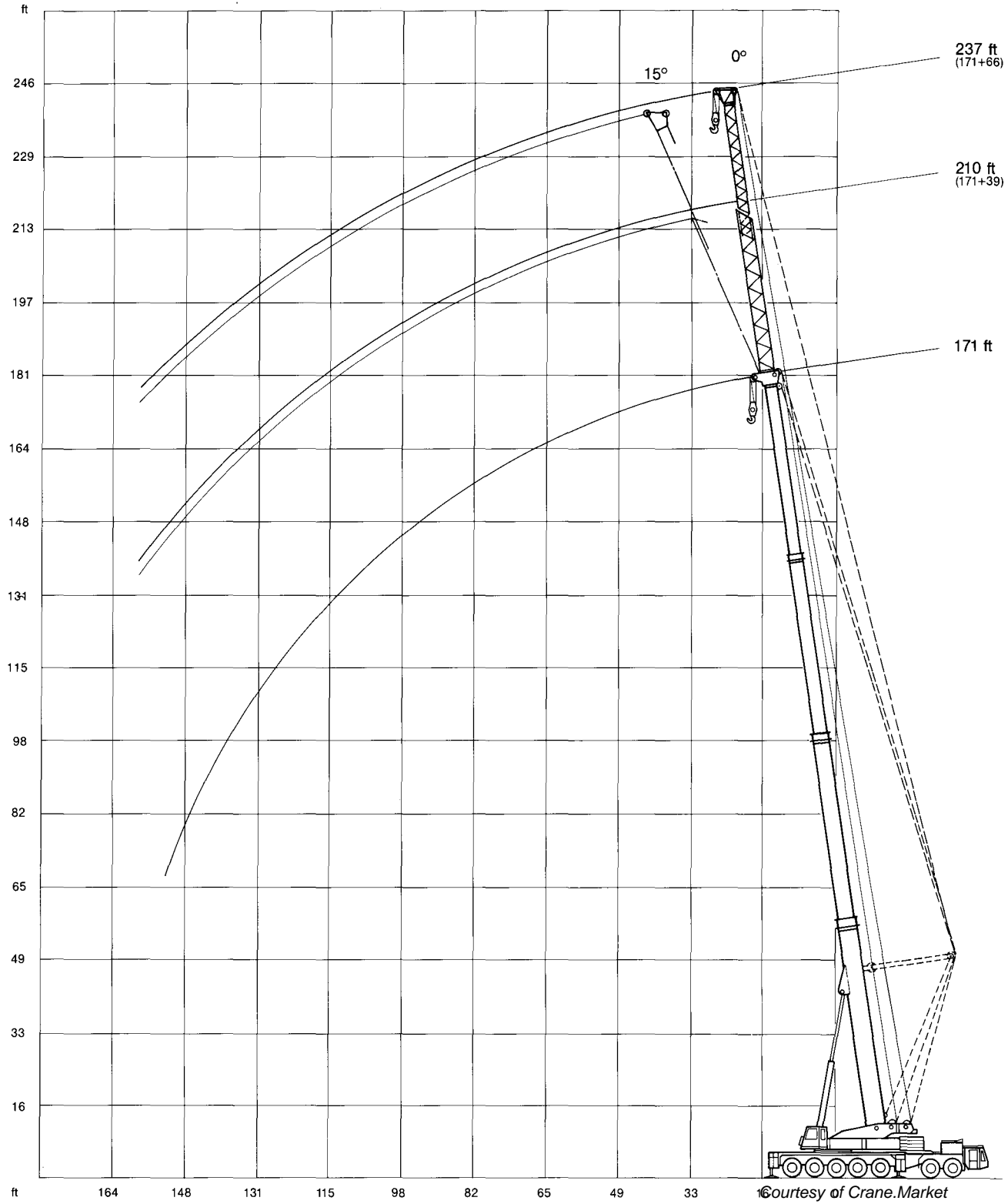

Working range fixed fly jib

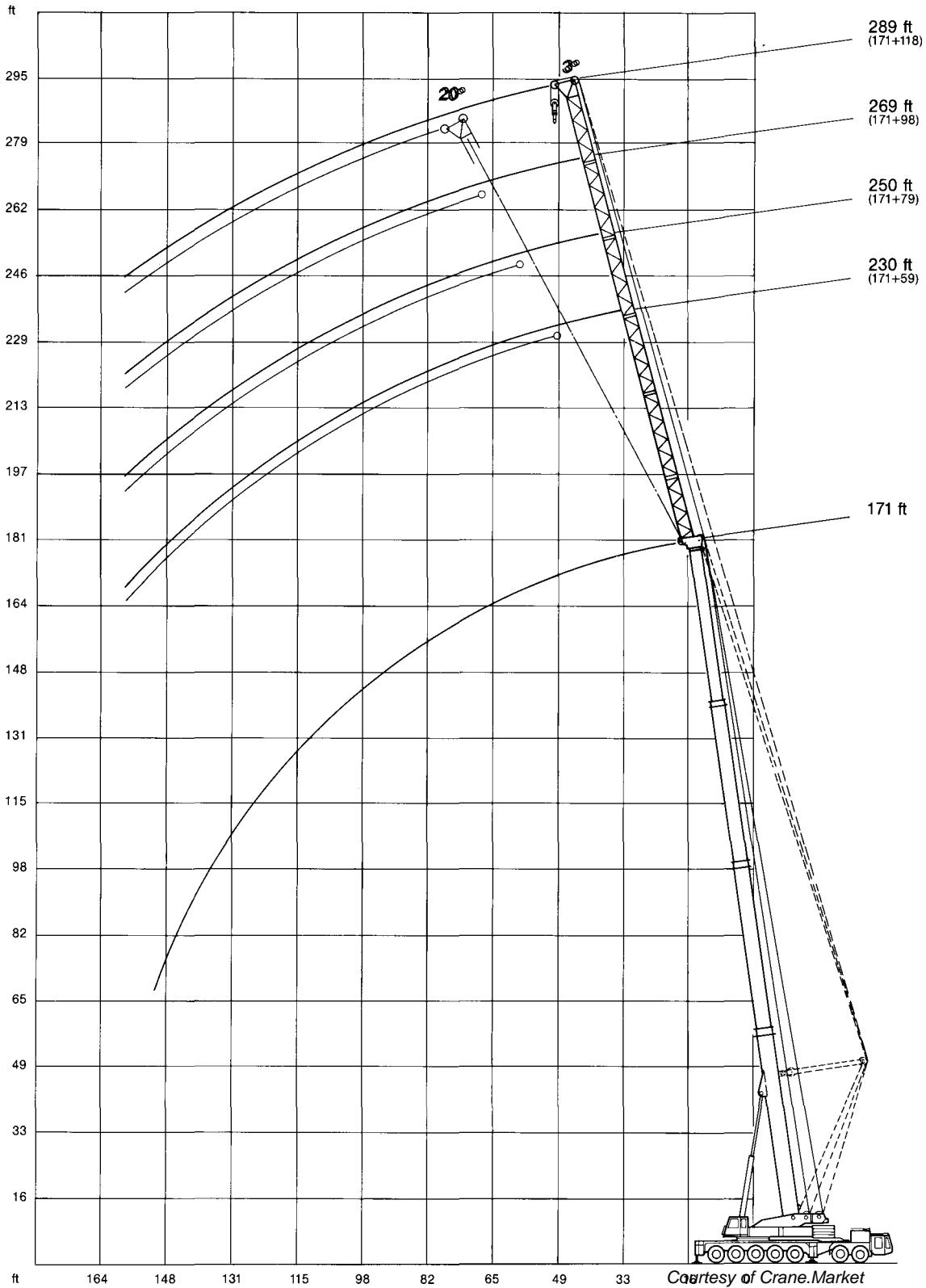

Lifting capacities fixed fly jib with Superlift in 1,000 lb

Main boom: 171 ft

141,000 lb  **360° 85%**

Radius ft	Extension							
	59 ft		79 ft		98 ft		118 ft	
	3°	20°	3°	20°	3°	20°	3°	20°
	1,000 lb							
39	45.0	-	-	-	-	-	-	-
46	43.4	29.5	37.7	-	-	-	-	-
52	41.9	27.5	35.9	-	28.8	-	-	-
59	40.1	26.0	34.1	-	27.5	-	-	-
66	38.1	24.4	32.2	18.5	26.4	-	21.6	-
72	36.1	22.9	30.4	17.4	25.1	-	20.5	-
79	34.1	21.6	28.6	16.3	24.0	13.4	19.4	-
85	32.1	20.5	26.9	15.2	22.7	13.0	18.5	-
92	30.4	19.2	25.3	14.3	21.4	12.5	17.4	10.8
98	28.6	18.0	23.6	13.4	20.3	12.1	16.5	10.3
105	27.1	16.9	22.5	12.5	19.2	11.4	15.4	9.9
112	25.5	16.1	20.9	11.9	17.8	11.0	14.5	9.4
118	24.0	15.0	19.4	11.2	16.9	10.3	13.4	9.0
125	22.4	13.9	18.3	10.5	15.8	9.7	12.3	8.6
131	21.1	13.0	17.0	9.9	15.0	9.0	11.6	7.9
138	19.6	12.1	15.8	9.2	13.6	8.6	11.0	7.5
144	18.5	11.2	14.7	8.6	12.5	8.1	9.9	7.0
151	17.2	10.3	13.6	8.1	11.9	7.5	9.2	6.4
157	15.8	9.7	13.0	7.7	11.0	7.0	8.3	5.9
164	15.0	9.0	12.1	7.0	9.9	6.6	7.7	5.5
170	13.6	8.3	11.4	6.6	8.8	6.1	7.0	5.0
177	12.3	7.7	11.0	6.1	8.6	5.7	6.4	4.6
183	11.2	7.2	10.1	5.7	7.7	5.3	5.9	4.2
190	9.9	6.8	9.9	5.3	7.0	4.8	5.0	3.7
197	-	6.4	7.9	4.8	6.1	4.4	4.2	3.3
206	-	-	-	4.4	-	3.9	-	3.0
210	-	-	-	3.9	-	3.7	-	2.8
216	-	-	-	3.5	-	3.3	-	2.4
223	-	-	-	-	-	2.8	-	2.0

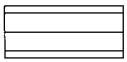
110,000 lb  **360° 85%**

Radius ft	Extension							
	59 ft		79 ft		98 ft		118 ft	
	3°	20°	3°	20°	3°	20°	3°	20°
	1,000 lb							
39	45.0	-	-	-	-	-	-	-
46	43.4	29.5	37.7	-	-	-	-	-
52	41.9	27.5	35.9	-	28.8	-	-	-
59	40.1	26.0	34.1	-	27.5	-	-	-
66	38.1	24.4	32.2	18.5	26.4	-	21.6	-
72	36.1	22.9	30.4	17.4	25.1	-	20.5	-
79	34.1	21.6	28.6	16.3	24.0	13.4	19.4	-
85	32.1	20.5	26.9	15.2	22.7	13.0	18.5	-
92	30.4	19.2	25.3	14.3	21.4	12.5	17.4	10.8
98	28.6	18.0	23.6	13.4	20.3	12.1	16.5	10.3
105	27.1	16.9	22.5	12.5	19.2	11.4	15.4	9.9
112	25.5	16.1	20.9	11.9	17.8	11.0	14.5	9.4
118	22.9	15.0	19.4	11.2	16.9	10.3	13.4	9.0
125	20.7	13.9	18.3	10.5	15.8	9.7	12.3	8.6
131	18.3	13.0	17.0	9.9	15.0	9.0	11.6	7.9
138	16.1	12.1	15.8	9.2	13.6	8.6	11.0	7.5
144	13.9	11.2	14.7	8.6	12.5	8.1	9.9	7.0
151	12.3	10.3	12.7	8.1	11.9	7.5	9.2	6.4
157	10.6	9.7	11.2	7.7	11.0	7.0	8.3	5.9
164	9.2	9.0	9.7	7.0	9.9	6.6	7.7	5.5
170	7.7	8.3	8.1	6.6	8.4	6.1	7.0	5.0
177	6.6	7.7	7.0	6.1	7.2	5.7	6.4	4.6
183	5.5	7.2	5.7	5.7	5.9	5.3	5.7	4.2
190	4.2	5.1	4.6	5.3	4.8	4.8	4.8	3.7
197	-	4.0	3.0	4.6	3.0	4.4	3.0	3.3
206	-	-	-	3.7	-	3.9	-	3.0
210	-	-	-	2.8	-	3.3	-	2.8
216	-	-	-	2.0	-	2.4	-	2.4
223	-	-	-	<i>Gourtesy of Crane Market</i>				-

Lifting capacities fixed fly jib in 1,000 lb

Main boom: 171 ft

110,000 lb  **360°** **85%**

Radius ft	Extension							
	59 ft		79 ft		98 ft		118 ft	
	3°	20°	3°	20°	3°	20°	3°	20°
	1,000 lb							
39	37.9	-	-	-	-	-	-	-
46	35.0	-	30.0	-	-	-	-	-
52	32.4	-	27.1	-	22.0	-	-	-
59	30.4	27.5	24.9	-	20.5	-	16.3	-
66	28.4	25.5	23.1	-	18.9	-	15.2	-
72	26.4	23.8	21.6	-	17.6	-	14.1	-
79	24.7	22.0	20.0	18.0	16.5	-	13.2	-
85	23.1	20.5	18.7	16.7	15.2	-	12.3	-
92	21.6	18.9	17.4	15.4	14.1	13.4	11.7	-
98	19.8	17.4	16.3	14.3	13.2	12.3	10.8	-
105	18.7	16.1	15.0	13.2	12.1	11.4	10.1	8.3
112	17.2	14.7	13.9	12.1	11.4	10.8	9.4	7.7
118	15.6	13.4	13.0	11.2	10.3	9.9	8.6	7.0
125	14.3	12.3	11.9	10.3	9.7	9.2	7.9	6.4
131	13.2	11.2	10.6	9.4	8.8	8.6	6.8	5.9
138	11.9	10.1	9.9	8.8	8.1	7.9	6.6	5.3
144	10.6	9.2	8.8	7.9	7.7	7.5	6.1	4.8
151	9.7	8.1	7.9	7.2	6.8	6.8	5.7	4.4
157	8.6	7.5	7.0	6.6	6.4	6.4	5.0	3.9
164	7.9	6.6	6.4	5.9	5.7	5.7	4.6	3.5
170	7.2	5.9	5.9	5.5	5.0	5.3	4.2	3.1
177	6.4	5.3	5.0	4.8	4.4	4.8	3.7	2.6
183	5.7	4.6	4.6	4.4	3.9	4.4	3.1	2.4
190	4.4	3.9	3.9	3.7	3.3	3.9	2.6	2.0
197	3.7	3.5	3.7	3.3	2.8	3.5	2.2	-

80,000 lb  **360°** **85%**

Radius ft	Extension							
	59 ft		79 ft		98 ft		118 ft	
	3°	20°	3°	20°	3°	20°	3°	20°
	1,000 lb							
39	37.9	-	-	-	-	-	-	-
46	35.0	-	30.0	-	-	-	-	-
52	32.4	-	27.1	-	22.0	-	-	-
59	30.4	27.5	24.9	-	20.5	-	16.3	-
66	28.4	25.5	23.1	-	18.9	-	15.2	-
72	26.4	23.8	21.6	-	17.6	-	14.1	-
79	24.7	22.0	20.0	18.0	16.5	-	13.2	-
85	23.1	20.5	18.7	16.7	15.2	-	12.3	-
92	21.6	18.9	17.4	15.4	14.1	13.4	11.7	-
98	19.8	17.4	16.3	14.3	13.2	12.3	10.8	-
105	18.7	16.1	15.0	13.2	12.1	11.4	10.1	8.3
112	17.2	14.7	13.9	12.1	11.4	10.8	9.4	7.7
118	15.6	13.4	13.0	11.2	10.3	9.9	8.6	7.0
125	13.7	12.3	11.9	10.3	9.7	9.2	7.9	6.4
131	11.7	11.2	10.6	9.4	8.8	8.6	6.8	5.9
138	9.9	10.1	9.9	8.8	8.1	7.9	6.6	5.3
144	8.1	9.2	8.8	7.9	7.7	7.5	6.1	4.8
151	6.6	8.1	7.2	7.2	6.8	6.8	5.7	4.4
157	5.5	7.3	5.9	6.6	6.2	6.4	5.0	3.9
164	4.2	5.5	4.4	5.9	4.6	5.7	4.6	3.5
170	3.1	4.4	3.5	5.3	3.7	5.3	3.7	3.1
177	2.2	3.5	2.4	4.0	2.6	4.6	2.6	2.6
183	-	2.4	-	3.1	-	3.7	-	2.4
190	-	-	-	2.2	-	2.4	-	2.0
197	-	-	-	-	-	-	-	-

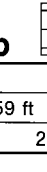
49,000 lb  **360°** **85%**

Radius ft	Extension							
	59 ft		79 ft		98 ft		118 ft	
	3°	20°	3°	20°	3°	20°	3°	20°
	1,000 lb							
39	37.9	-	-	-	-	-	-	-
46	35.0	-	30.0	-	-	-	-	-
52	32.4	-	27.1	-	22.0	-	-	-
59	30.4	27.5	24.9	-	20.5	-	16.3	-
66	28.4	25.5	23.1	-	18.9	-	15.2	-
72	26.4	23.8	21.6	-	17.6	-	14.1	-
79	24.7	22.0	20.1	18.0	16.5	-	13.2	-
85	22.0	20.5	18.7	16.7	15.2	-	12.3	-
92	18.3	18.9	17.4	15.4	14.1	13.4	11.7	-
98	15.0	17.4	15.4	14.3	13.2	12.3	10.8	-
105	11.9	14.8	12.8	13.2	12.1	11.4	10.1	8.3
112	9.9	11.9	10.1	12.1	10.6	10.8	9.4	7.7
118	7.7	9.2	7.9	11.0	8.2	9.9	8.6	7.0
125	5.9	7.9	6.2	9.0	6.4	9.2	6.8	6.4
131	4.2	6.2	4.6	7.3	5.1	7.9	5.1	5.9
138	3.1	4.4	3.3	5.5	3.5	6.2	3.5	5.3
144	-	3.1	2.0	4.0	2.2	4.6	2.2	4.8
151	-	1.8	-	2.8	-	3.5	-	4.0
157	-	-	-	-	-	2.2	-	2.4

Working range luffing fly jib, main boom 70°

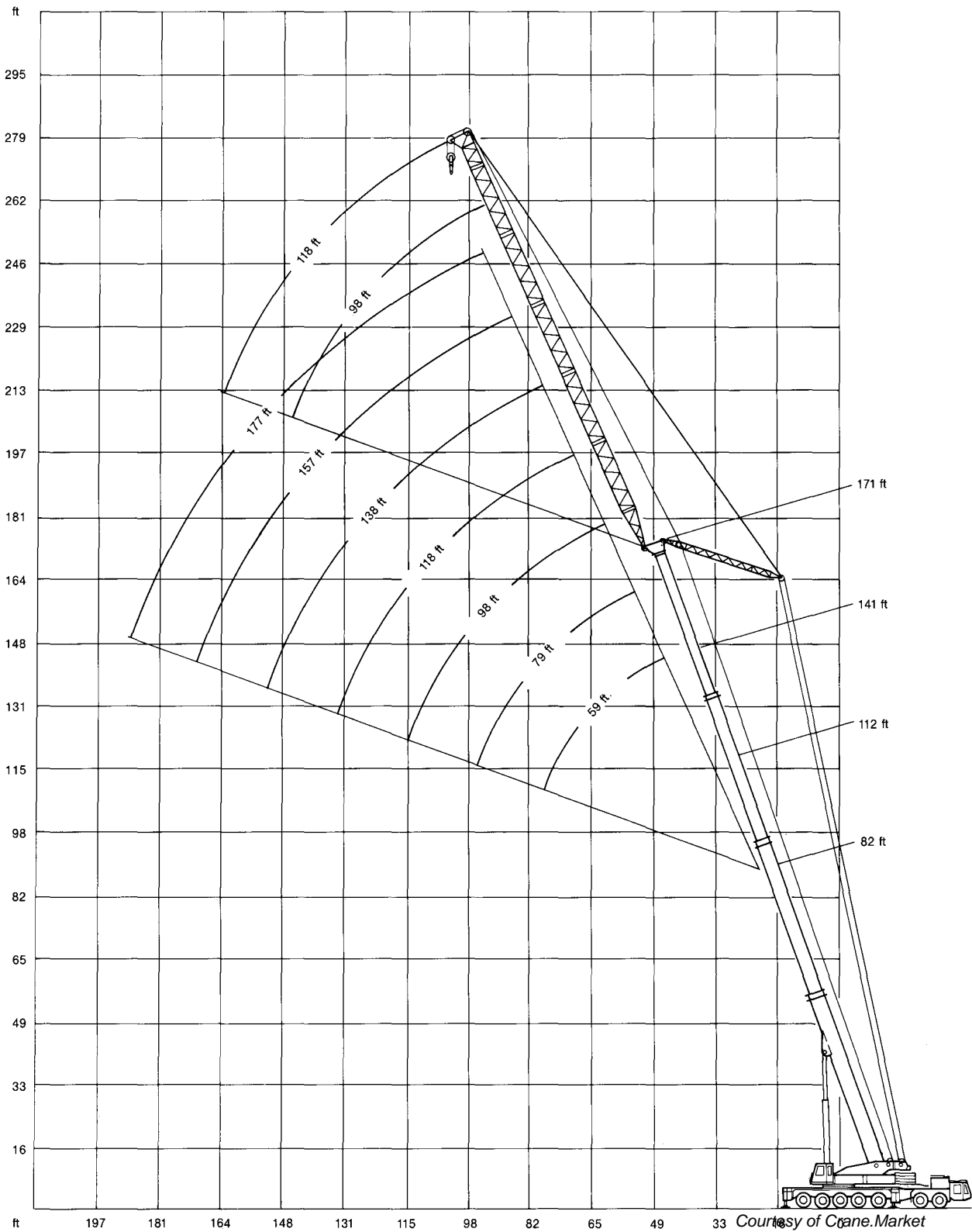

Lifting capacities luffing fly jib, main boom 70°, in 1,000 lb

110,000 lb

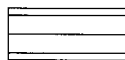

360°

75%

Boom	Radius ft	Main boom						
		59 ft	79 ft	98 ft	118 ft	138 ft	157 ft	177 ft
82 ft					1,000 lb			
	52	<u>105.8</u>	-	-	-	-	-	-
	59	97.0	-	-	-	-	-	-
	66	83.8	<u>81.6</u>	-	-	-	-	-
	72	74.9	72.7	<u>68.3</u>	-	-	-	-
	79	66.1	66.1	63.9	52.9	-	-	-
	85	-	59.5	57.3	50.7	-	-	-
	92	-	52.9	52.9	<u>50.7</u>	40.8	-	-
	98	-	48.5	48.5	48.5	39.7	-	-
	105	-	-	45.1	44.7	38.5	29.1	-
	112	-	-	42.1	41.2	<u>37.4</u>	28.2	20.9
	125	-	-	-	35.7	34.6	26.6	19.8
	138	-	-	-	31.3	30.4	25.1	18.7
	151	-	-	-	-	25.3	23.5	16.5
164	-	-	-	-	-	<u>20.5</u>	14.3	
177	-	-	-	-	-	-	12.1	
190	-	-	-	-	-	-	<u>11.0</u>	
112 ft	72	-	43.2	-	-	-	-	-
	79	-	42.3	-	-	-	-	-
	85	-	41.4	37.0	-	-	-	-
	92	-	40.5	35.0	30.8	-	-	-
	98	-	<u>39.6</u>	33.2	29.7	-	-	-
	105	-	-	32.6	28.9	25.3	-	-
	112	-	-	32.0	27.7	24.4	20.9	-
	125	-	-	<u>31.5</u>	26.0	22.7	19.8	17.4
	138	-	-	-	<u>24.7</u>	21.1	18.7	16.5
	151	-	-	-	-	20.2	17.6	15.6
164	-	-	-	-	<u>19.6</u>	16.7	14.7	
177	-	-	-	-	-	<u>15.8</u>	14.1	
190	-	-	-	-	-	-	<u>12.1</u>	
141 ft	85	-	32.0	-	-	-	-	-
	92	-	30.8	26.9	-	-	-	-
	98	-	30.0	26.2	-	-	-	-
	105	-	29.1	25.5	21.6	-	-	-
	112	-	<u>28.2</u>	24.7	20.9	16.5	-	-
	125	-	-	23.1	19.6	15.6	12.8	-
	138	-	-	<u>22.0</u>	18.5	14.7	12.3	-
	151	-	-	-	<u>17.8</u>	14.1	11.9	-
	164	-	-	-	-	13.6	11.4	-
	177	-	-	-	-	<u>13.6</u>	11.0	-
190	-	-	-	-	-	<u>10.5</u>	-	
171 ft	105	-	-	13.2	-	-	-	-
	112	-	-	12.3	10.1	-	-	-
	125	-	-	11.4	9.2	-	-	-
	138	-	-	<u>10.3</u>	8.3	-	-	-
	151	-	-	-	<u>7.7</u>	-	-	-

Working range luffing fly jib, main boom 84°

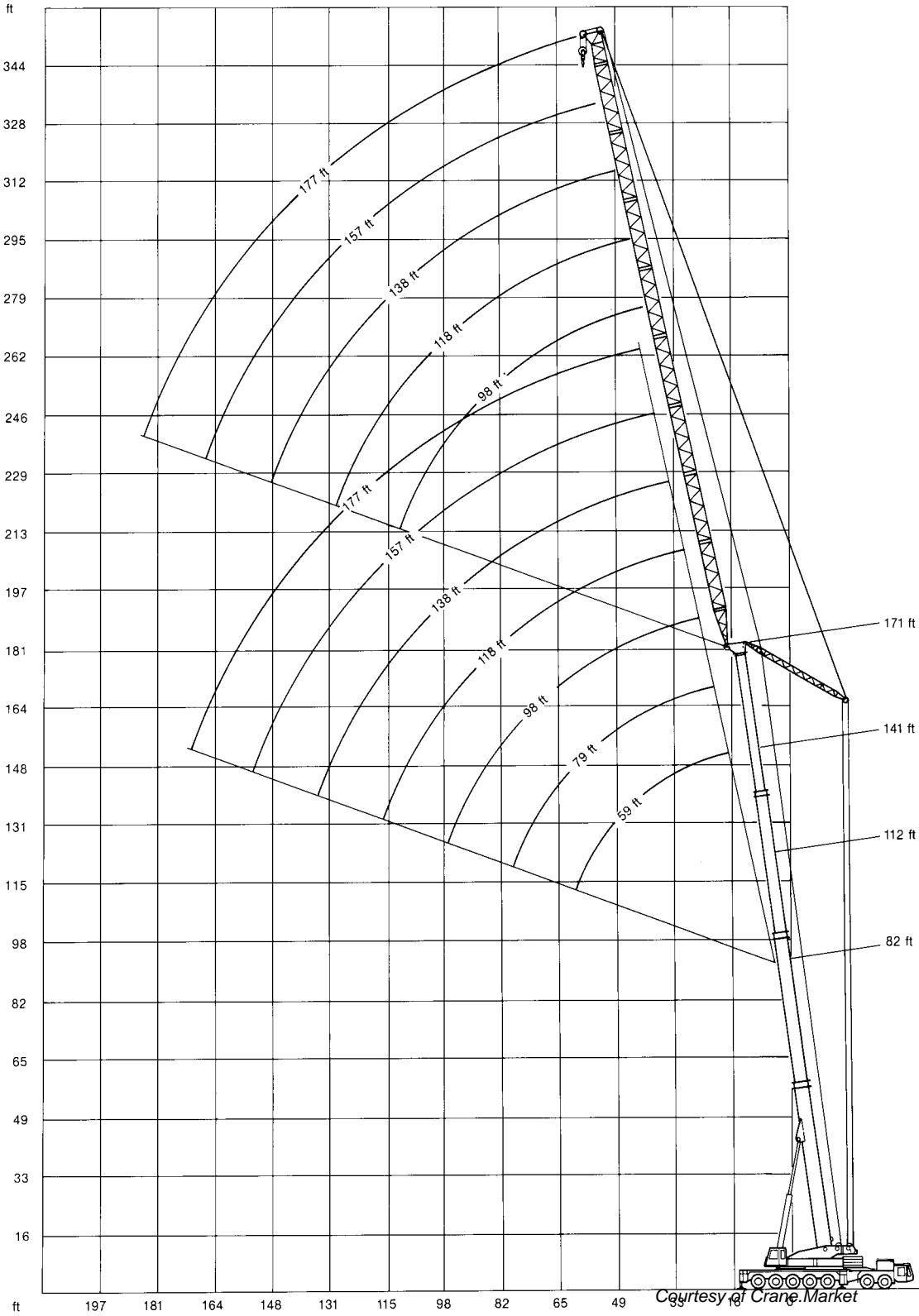

Lifting capacities luffing fly jib, main boom 84°, in 1,000 lb

110,000 lb

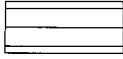

360°

75%

Boom	Radius ft	Main boom						
		59 ft ¹⁾	79 ft ²⁾	98 ft	118 ft	138 ft	157 ft	177 ft
					1,000 lb			
82 ft	23	154.0	-	-	-	-	-	-
	26	137.0	-	-	-	-	-	-
	29	131.0	118.0	-	-	-	-	-
	33	125.0	113.0	-	-	-	-	-
	36	119.0	109.5	96.8	69.0	-	-	-
	39	113.0	106.0	93.7	69.0	-	-	-
	46	102.0	101.0	89.3	69.0	61.6	-	-
	52	86.4	96.1	85.5	69.0	61.6	48.5	-
	59	-	88.2	82.6	69.0	61.6	45.6	34.8
	66	-	74.0	80.4	69.0	59.7	43.2	32.6
	72	-	58.2	72.1	67.9	57.7	40.8	30.4
	79	-	-	61.3	66.1	55.1	38.6	28.2
	85	-	-	51.1	59.3	52.4	36.3	26.4
	92	-	-	41.2	51.8	49.8	34.6	24.7
	98	-	-	-	44.7	47.4	32.6	22.5
	112	-	-	-	30.8	37.0	29.1	20.3
125	-	-	-	-	27.1	26.0	17.6	
138	-	-	-	-	-	22.9	15.4	
151	-	-	-	-	-	16.3	13.2	
164	-	-	-	-	-	-	11.0	
112 ft	33	-	79.8	-	-	-	-	-
	36	-	78.2	-	-	-	-	-
	39	-	78.2	62.8	-	-	-	-
	46	-	76.0	61.7	50.2	-	-	-
	52	-	73.8	61.0	49.4	39.4	-	-
	59	-	72.1	59.7	48.7	38.8	32.2	-
	66	-	69.6	58.6	48.3	38.3	32.0	25.8
	72	-	66.1	58.2	48.0	38.1	31.5	25.1
	79	-	51.6	58.0	47.8	37.9	31.1	24.4
	85	-	-	56.8	47.8	37.9	30.8	23.8
	92	-	-	47.4	47.6	37.9	30.0	23.1
	98	-	-	-	46.3	37.9	29.3	22.2
	112	-	-	-	35.2	37.0	28.0	20.0
	125	-	-	-	-	32.6	25.5	18.0
	138	-	-	-	-	-	22.9	16.1
	151	-	-	-	-	-	19.2	14.1
164	-	-	-	-	-	-	12.1	
141 ft	39	-	49.4	-	-	-	-	-
	46	-	48.9	37.4	-	-	-	-
	52	-	48.7	37.2	30.4	24.7	-	-
	59	-	48.7	37.0	30.0	24.2	19.8	-
	66	-	48.5	37.0	29.7	24.0	19.4	15.4
	72	-	48.0	37.0	29.7	23.8	19.2	15.4
	79	-	47.6	37.0	29.7	23.8	18.7	14.7
	85	-	-	37.0	29.7	23.8	18.5	14.5
	92	-	-	37.0	29.7	23.8	18.5	14.5
	98	-	-	-	29.7	23.8	18.5	14.3
	112	-	-	-	29.7	23.8	18.5	14.3
	125	-	-	-	-	23.1	18.5	14.3
	138	-	-	-	-	-	18.5	13.6
	151	-	-	-	-	-	18.5	12.1
	164	-	-	-	-	-	-	10.1
	171 ft	46	-	-	24.2	-	-	-
52		-	-	24.2	19.2	-	-	-
59		-	-	24.2	19.2	15.8	-	-
66		-	-	24.2	19.2	15.4	12.1	9.0
72		-	-	24.2	19.2	15.2	11.9	8.8
79		-	-	24.2	19.2	15.0	11.7	8.6
85		-	-	24.2	19.2	15.0	11.4	8.3
92		-	-	24.2	19.2	14.7	11.2	8.3
98		-	-	-	19.2	14.7	11.2	8.1
112		-	-	-	19.2	14.7	11.2	7.9
125		-	-	-	-	14.7	11.2	7.9
138		-	-	-	-	-	11.0	7.7
151		-	-	-	-	-	11.0	7.7
164		-	-	-	-	-	-	7.5

1) hook block (8 sheaves, weight 3.96 lb) required

2) hook block (3 sheaves, weight 2.53 lb) required

Carrier

Demag truck-type carrier	Drive 14 x 6
Frame	Monobox main frame with outrigger boxes integral, fabricated from high strength fine-grained structural steel.
Outriggers	Four hydraulic telescopic beam and jack outriggers plus front jack leg for 360° continuous rotation.
Engine	Daimler-Benz OM-424 A water-cooled 12-cylinder diesel engine. Output to DIN: 390 kW (530 hp). Fuel tank capacity: 500 l.
Transmission	Allison CLBT-754 automatic transmission.
Axles	All axles are sprung and single-wheeled. Steering axles: 1st, 2nd, 3rd, 6th, 7th. Drive axles: 1st, 4th, 5th.
Wheels and tyres	14 disk-type wheels with 10.0–25 rims and single 14.00–25 tyres, plus one spare.
Steering	ZF semiblock mechanical steering with hydraulic booster.
Brakes	to EC standards.
Electrical equipment	24-volt system.
Cab	Rubber-mounted low-line two-man steel cab.

Superstructure

Frame	Torsion-resistant welded structure of fine-grained structural steel.
Paneling	Sectional side panels which are removable for service accessibility.
Slew ring	Triple-row roller bearing type with external ring gear.
Engine	Daimler-Benz OM-441 water-cooled 6-cylinder diesel engine. Output to DIN: 160 kW (218 hp). Fuel tank capacity: 300 l.
Hydraulic system	2 variable-displacement axial-piston pumps with automatic power control and 1 fixed-displacement tandem pump (enable the operator to engage three motions at the same time). 1 fixed-displacement pump for low-pressure servo control.
Hoist	Hydromatik variable-displacement axial-piston hydraulic motor with planetary reduction and spring-loaded multiple-disk brake in hoist drum, hoist rope (Ø 1").
Slewing	Axial-piston hydraulic motor with planetary reduction integral. Foot-pedal operated service brake and spring-loaded holding brake.
Boom elevation	Two hydraulic cylinders with pilot-controlled braking valve for lowering.
Cab	Comfortable all-steel cab with sliding door, large folding-out front window, roof window, air heating and ventilation system. The cab is hydraulically tiltable to an angle of 15°.
Main boom	Four-section power-telescoping boom, fabricated from high-grade close-grained plate stock, featuring the familiar DEMAG „ovaloid“ design of rectangular box members with rounded-off corners. Each center section slides on diagonally self-centering plastic shoes. Boom head with mounting lugs for extension boom and luffing fly jib.
Safety devices	Electronic safe load indicator, limit switches on hoist and lowering motions, pressure-relief and safety holding valves.
Hydraulic servo control	By self-centering control levers.

Optional Equipment

Superlift attachment	The Superlift attachment is a means to increase the crane's lifting capacity. It essentially consists of a boom-suspension mast with guy ropes, which provides for an automatic rope-length adjustment for boom telescoping, and a 44,000 lb Superlift counterweight. The suspension mast is lowered to the main boom when not needed, or for road transport. No auxiliary crane is required to mount or remove the counterweights.
2nd Hoist (removable)	The 2nd hoist unit avoids re-reeving the hoist line when using the optional extension boom. It is indispensable for fly jib luffing. The unit is powered by a variable-displacement axial-piston hydraulic motor, through a planetary reduction, integral with the drum and equipped with a spring-loaded multi-disk brake, and ropes.
Main boom extension	39-66 ft telescoping side-folding 2-part extension boom, with adapter to permit an angular adjustment of 0° and 15°.
Fixed fly jib	Non-folding fixed fly jib of 59 ft, 79 ft, 98 ft and 118 ft length, using components of the luffing fly jib (angular adjustment 6° and 20°).
Luffing fly jib	59-177 ft length, with luffing mast, guy ropes, electrical equipment, and safety devices (the 2nd hoist unit is required when using the luffing fly jib).
"Heavy-lift" boom	39-52 ft boom with heavy-lift workshop head and quick assembly system.
Trailer hitch	26,400 lb capacity, with air brake hookup.

Courtesy of Crane.Market