

DEMAG

Lattice Boom Crane

TC 2000S

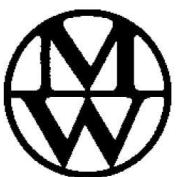

**MANNESMANN
DEMAG**

Construction Machinery Courtesy of Crane.Market

Basic Machine

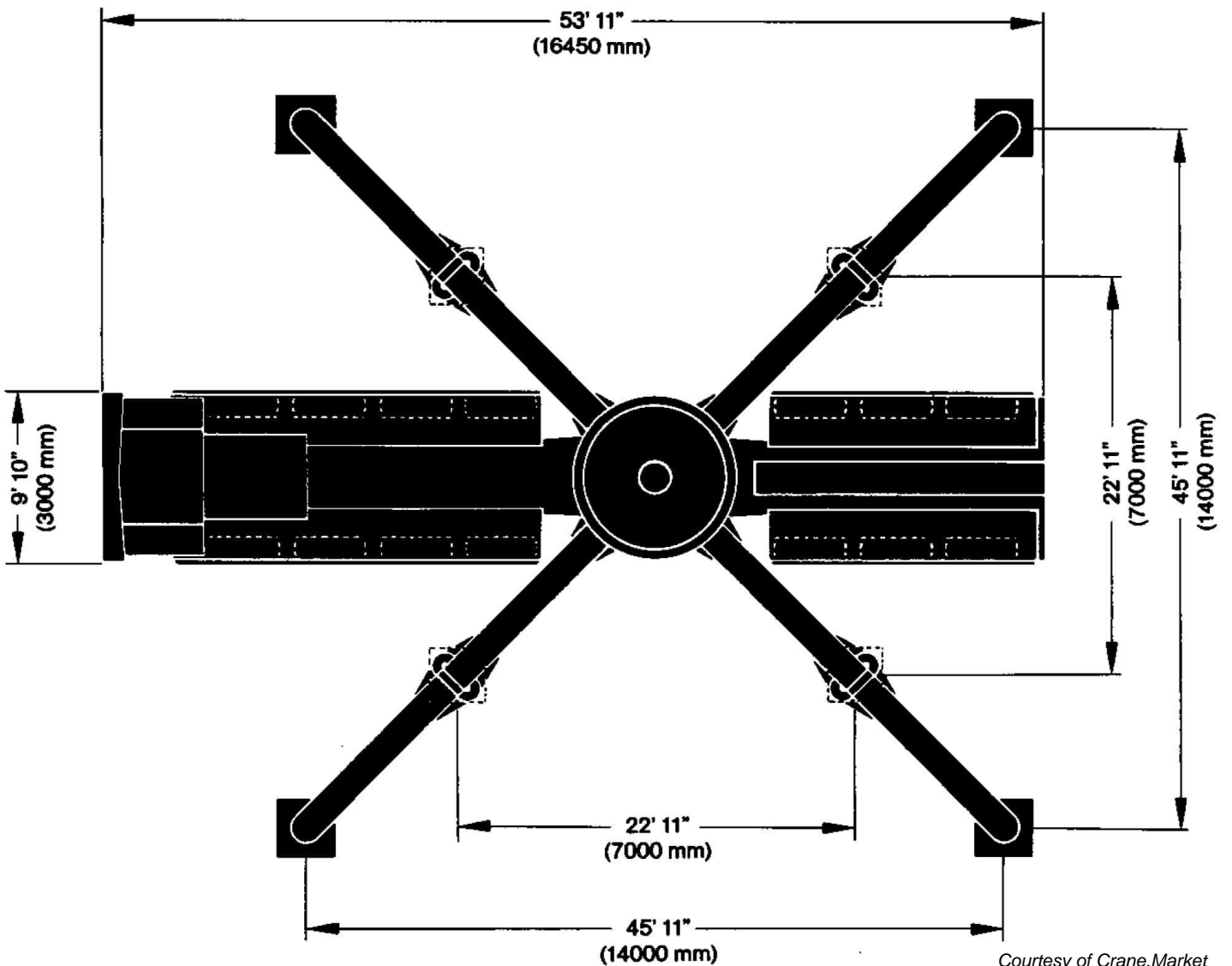
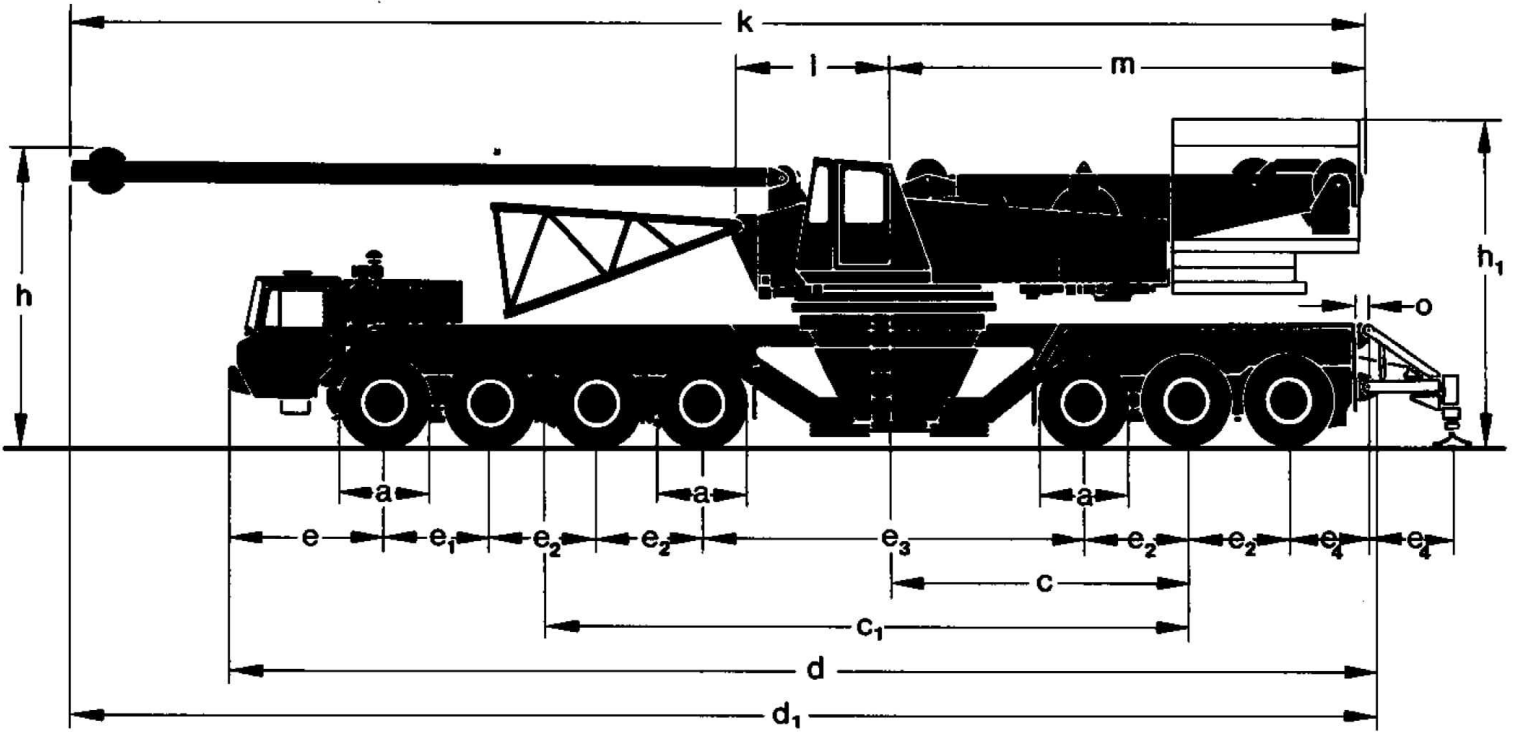

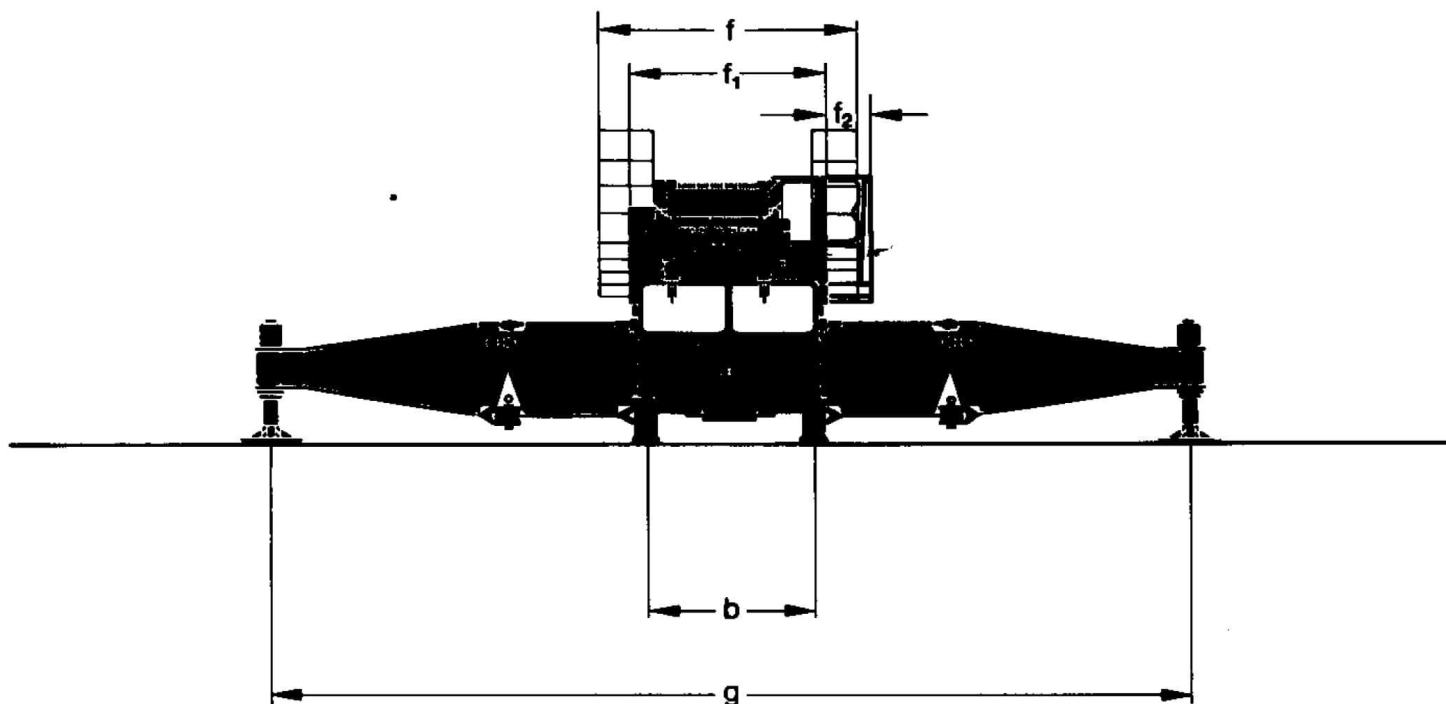

a	14.00 - 24, PR 22	d	54' 9" (16710 mm)	e ₄	3' (1150 mm)	h ₁	15' (4575 mm)
b	8' 5" (2503 mm)	d ₁	62' 2" (18950 mm)	f	15' 9" (4790 mm)	k	61' 4" (18700 mm)
c	13' 9" (4200 mm)	e	8' (2450 mm)	f ₁	9' 10" (3000 mm)	l	7' 2" (2200 mm)
c ₁	30' " (9150 mm)	e ₁	5' 3" (1600 mm)	f ₂	2' 4" (700 mm)	m	22' (6710 mm)
		e ₂	4' 11" (1500 mm)	g	45' 11" (14000 mm)	o	6' (150 mm)
		e ₃	17' 8" (5400 mm)	h	12' 11" (3950 mm)		

Truck Carrier

Engine	KHD-BF 12 L 413 F
System	12 cyl.-4 strokes
Output (DIN 70020) at 2100 RPM	353 kW (480 HP)
Cooling	air
Fuel-Tank Capacity	113 gal. (430 liters)
Transmission	* 8-Speed Synchronmesh Torque-Converter Main Transmission plus Transfer Case and Differential with Lock-Out Control
Carrier	14 x 8
Driving Axles	1st, 2nd, 5th, 6th
Steering Axles	1st, 2nd, 3rd, 5th, 6th, 7th
Suspension	
Front	1st and 2nd Axles: Leaf springs; 3rd and 4 th = Hydraulic Suspension
Rear	1st and 2nd Axles = Walking Beams, 3rd = Hydraulic Suspension
Outriggers	4 articulated dismountable outrigger beams with hydraulic jack legs



Axle Loads

	1st front	2nd front	3rd front	4th front	1st rear	2nd rear	3rd rear	Total
	tons	tons	tons	tons	tons	tons	tons	tons
Crane in travel order, with basic boom and mast gantry, without outriggers	10.5*	10.5	13.2	13.2	13.2	13.2	13.2	87.0

Change of Road Weight

Deduct for: 2nd Hoist Drum with Cable	-0.31	-0.31	0	0	-1.69	-1.69	0	-4.00
Deduct for: Jib-Boom Luffing Drum with Cable	-0.33	-0.33	0	0	-0.91	-0.91	0	-2.48
Deduct for: Main Hoist and Boom Hoist Cable	-0.65	-0.65	0	0	-1.98	-1.98	0	-5.26
Deduct for: 2nd Hoist Cable	-0.20	-0.20	0	0	-1.07	-1.07	0	-2.54
Deduct for: Jib-Boom Luffing Cable	-0.15	-0.15	0	0	-0.42	-0.42	0	-1.14
Deduct for: Basic Boom plus Mast Gantry	-3.10	-3.10	0	0	+0.23	+0.23	0	-5.74



Carrier Weight

	10.5	10.5	0*	0	10.4	10.4	0	41.8
--	------	------	----	---	------	------	---	------

* When adjusting the load on each of the 3rd and 4th front axle and the 3rd rear axle to a certain value "X", the load on each of the 1st and 2nd front axle will be reduced by "X" multiplied by 1.28 t, and on each of the 1st and 2nd rear axle by "X" multiplied by 2.03 t.

Carrier Performance

Travel Speeds

0 ... 38.4 mph (0 ... 61.9 km/h)

Gradeability

max. 30.7%

Courtesy of Crane.Market

Superstructure

Engine	KHD-F 10 L 413 F
Output at 2300 RPM	196 kW (267 HP)
Transmission	Axial-Piston Hydraulic Pumps
Drum Drive	Axial-Piston Hydraulic Motor and Planetary Drive
Swing Drive	Axial-Piston Hydraulic Motor and Planetary Drive
Control	Hydraulic

Working Speeds

	Infinitely variable
Main Hoist	max. 295 ft./min. (max. 90 m/min.)
Aux. Hoist	max. 387 ft./min. (max. 118 m/min.)
Aux. Boom Hoist	max. 141 ft./min. (max. 43 m/min.)
Main Boom Hoist	max. 118 ft./min. (max. 36 m/min.)
Swing	1.1 RPM

Cables

Main Hoist: Rope Pull, Single Line	(75%) 27.557 lbs. (12500 kg) (85%) 31.300 lbs. (14200 kg)	Aux. Hoist: Rope Pull, Single Line	(75%) 20.282 lbs. (9200 kg)
Length of Cable	2789 ft. (850 m)	Length of Cable	2460 ft. (750 m)
Dia. of Cable	1 ⁷ / ₆₄ " (28 mm)	Dia. of Cable	1 ¹ / ₃₂ " (26 mm)

Boom

	Main Boom	Max. Allowable Lifting Load	Main Boom + Jib Boom
Heavy-Duty Hammer Head	39–59 ft. (12–18 m)	440 tons (400 t)	–
Universal Head	39–295 ft. (12–90 m)	350 tons (300 t)	276 + 236 ft. (84 + 72 m)

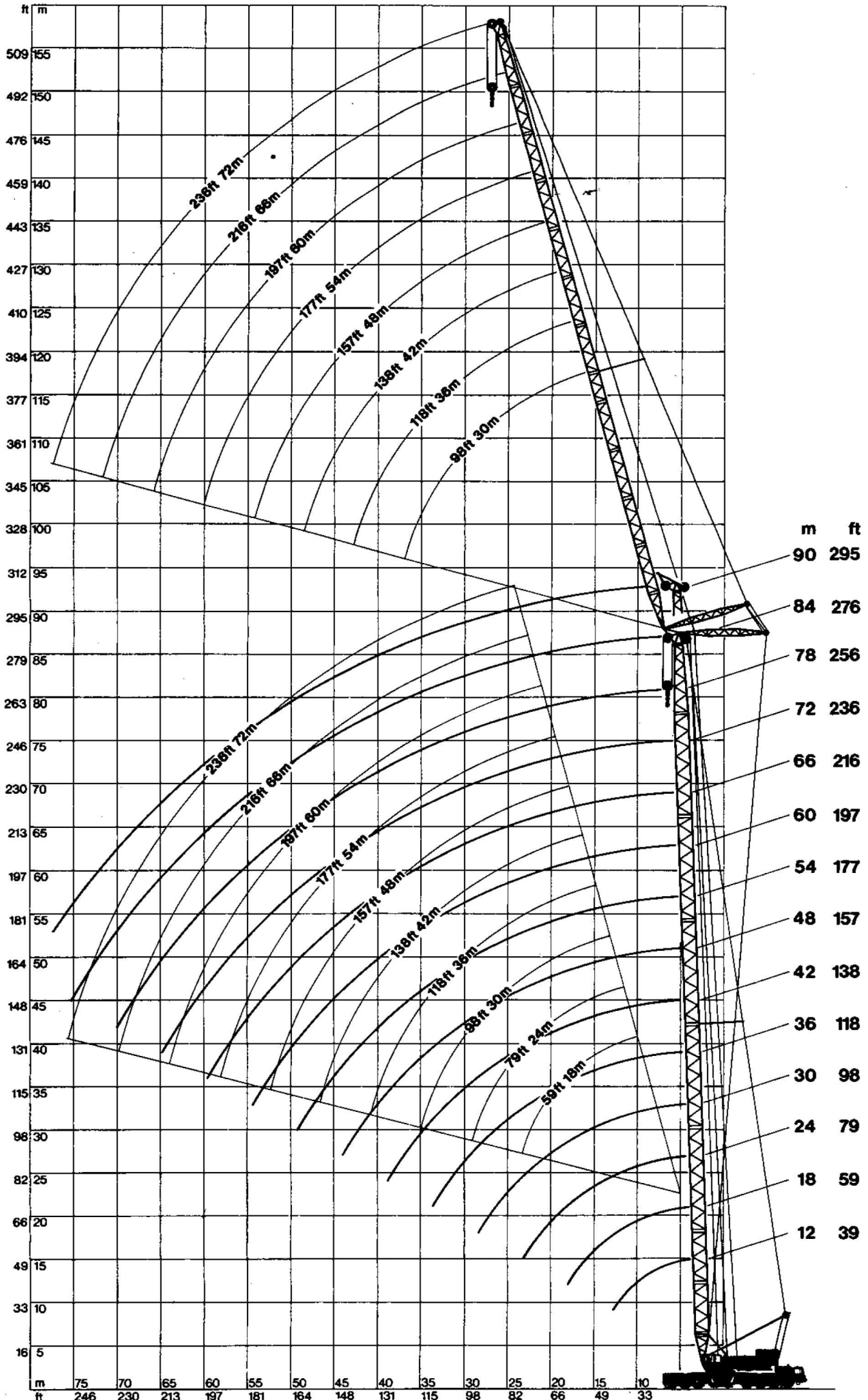

Lifting Capacities on Main Boom, with Outriggers, 360° 85 %

Radius ft	Length of Main Boom													
	39 ft	59 ft	79 ft	98 ft	118 ft	138 ft	157 ft	177 ft	197 ft	216 ft	236 ft	256 ft	276 ft	295 ft
18	440*	440*	-	-	-	-	-	-	-	-	-	-	-	-
20	398*	398*	-	-	-	-	-	-	-	-	-	-	-	-
23	350	350	348	344	292	-	-	-	-	-	-	-	-	-
26	313	311	310	309	269	253	-	-	-	-	-	-	-	-
30	275	273	272	269	250	236	222	-	-	-	-	-	-	-
33	245	244	242	239	234	222	211	188	163	135	112	-	-	-
39	201	199	198	196	194	183	192	170	152	126	104	90	76.3	62.4
46	-	169	167	163	162	162	162	155	141	118	97.7	83.4	70.2	55.9
53	-	146	144	143	141	140	138	137	133	111	91.1	77.9	64.7	51
59	-	128	126	125	124	123	122.9	122	121	104	85.6	72.4	60.3	47.1
66	-	-	113	112	111	110	109	108	107	96.6	80.1	68	55.9	43.3
72	-	-	103	101	100	98.8	97.7	96.9	96	89.4	75.7	63.6	52.1	40.5
79	-	-	-	92.1	90.8	89.6	88.5	87.5	86.6	82.3	71.3	59.2	48.2	37.8
85	-	-	-	84.4	82.9	81.8	80.7	79.7	78.8	75.7	66.9	55.9	44.9	35.6
92	-	-	-	77.9	76.3	75.2	74	73.1	72.1	70.7	63.6	52.6	42.3	32.4
98	-	-	-	-	70.7	69.5	68.3	67.2	66.4	63.6	59.2	49.3	39.4	31.4
112	-	-	-	-	-	60.1	58.9	57.8	57.0	53.7	51.5	42.7	34.6	28.4
125	-	-	-	-	-	53	50.8	50	49.6	47.1	44.9	38.3	30.6	24.6
138	-	-	-	-	-	-	44.7	43.5	42.7	40.5	38.9	32.8	27.3	21.8
151	-	-	-	-	-	-	-	38.5	37.8	35.8	33.9	28.4	24	19.6
164	-	-	-	-	-	-	-	-	33.4	31.6	30.1	25.3	21.3	17.4
177	-	-	-	-	-	-	-	-	29.4	28.1	26.8	21.8	19.1	15.2
190	-	-	-	-	-	-	-	-	-	25.4	23.7	19.6	16.9	13.4
203	-	-	-	-	-	-	-	-	-	-	21.3	17.4	13.4	11.6
216	-	-	-	-	-	-	-	-	-	-	-	15.2	12.9	9.9
229	-	-	-	-	-	-	-	-	-	-	-	13.6	12	8.5

Crane-Capacity Notes

Capacities do not exceed 85%/75% of tipping load

Max. wind pressure: 15 kg/m² △ 15,5 m/sec (85%)

25 kg/m² △ 20 m/sec (75%)

Crane operation up to a wind force of 5^o Beaufort scale (5 kg/m² △ 9 m/sec) permissible.

The weights of all load-handling devices are considered part of the load, and suitable allowance for them should be made.

The 75% crane ratings furthermore comply with DIN 15019,2 (test load = 1.25x lifting load + 0.1 x dead weight of boom reduced to the boom point)

All capacities above the parting line are based upon structural strength. The capacities below the parting line are based on stability.

* With Heavy-Duty Hammer Head

Crane Attachment

Crane Attachment	Width	Height	Length
Main Boom:			
Foot Section	7'06"	5'08"	11'06"
Inserts	7'06"	5'08"	19'08"/29'07" 39'05"
Head Section	4'06"	5'08"	24'
Jib Boom:			
Foot Section	4'11"	4'01"	18'02"
Inserts	4'11"	4'01"	9'10"/19'08" 39'05"
Head Section	4'09"	4'01"	18'02"

Based on a main-boom angle of 88°
All capacities above the parting line are based upon structural strength.

Lifting Capacities on Luffing Jib Boom, with Outriggers, 360° 75%

Main Boom	Radius ft	Length of Jib Boom													
		59 ft	79 ft	98 ft	118 ft	138 ft	157 ft	177 ft	197 ft	216 ft	236 ft				
		tons	tons	tons	tons	tons	tons	tons	tons	tons	tons				
59 ft (18 m)	39	130	122	-	-	-	-	-	-	-	-	-	-	-	
	46	123	114	102	84.2	-	-	-	-	-	-	-	-	-	
	53	103	104	96.8	82.5	69.3	-	-	-	-	-	-	-	-	
	59	84.7	90.8	90.8	80.3	67.8	-	-	-	-	-	-	-	-	
	66	74.3	79.2	77.8	77.8	66.0	55.0	-	-	-	-	-	-	-	
	72	-	69.3	72.6	73.7	63.8	51.7	40.8	-	-	-	-	-	-	
	79	-	61.1	64.0	66.3	61.6	52.8	39.6	32.2	-	-	-	-	-	
	85	-	54.0	56.7	59.4	58.3	51.7	38.8	31.5	28.1	-	-	-	-	
	92	-	-	50.1	52.8	52.3	50.6	38.1	30.8	27.1	23.1	-	-	-	
	98	-	-	44.7	46.8	48.4	48.4	37.2	29.9	26.0	23.1	23.1	-	-	
	112	-	-	-	44.7	48.4	46.2	36.3	29.2	25.1	22.9	21.6	21.6	-	-
	125	-	-	-	-	49.0	44.0	34.1	27.5	25.1	23.3	21.6	21.6	21.6	-
	138	-	-	-	-	33.9	33.9	31.5	25.6	23.7	21.6	20.1	20.1	20.1	-
	151	-	-	-	-	29.4	29.4	27.7	23.7	21.9	19.9	18.6	18.6	18.6	-
	164	-	-	-	-	-	25.3	24.4	21.5	19.4	18.6	17.2	17.2	17.2	-
177	-	-	-	-	-	-	21.7	19.4	17.6	16.0	14.3	14.3	14.3	-	
190	-	-	-	-	-	-	19.8	17.6	16.2	14.9	13.2	13.2	13.2	-	
203	-	-	-	-	-	-	-	16.2	14.9	13.9	12.2	12.2	12.2	-	
217	-	-	-	-	-	-	-	-	13.2	13.2	11.2	11.2	11.2	-	
230	-	-	-	-	-	-	-	-	-	10.5	10.5	10.5	10.5	-	
79 ft (24 m)	39	130	121	-	-	-	-	-	-	-	-	-	-	-	
	46	125	115	100	-	-	-	-	-	-	-	-	-	-	
	53	107	106	96.3	80.3	66.0	-	-	-	-	-	-	-	-	
	59	90.8	94.1	91.9	79.4	65.5	-	-	-	-	-	-	-	-	
	66	77.9	81.6	83.3	77.3	64.6	51.9	-	-	-	-	-	-	-	
	72	-	71.0	72.8	74.3	63.6	51.5	52.8	-	-	-	-	-	-	
	79	-	62.2	64.9	67.1	62.2	50.8	47.7	41.9	-	-	-	-	-	
	85	-	55.0	57.4	60.2	59.4	49.7	47.7	40.7	33.6	-	-	-	-	
	92	-	-	52.4	54.1	55.0	48.4	48.4	39.9	32.9	28.1	-	-	-	
	98	-	-	46.3	48.4	49.0	47.3	47.3	39.2	32.1	27.1	22.0	-	-	
	112	-	-	-	46.3	48.4	47.3	47.3	38.3	31.2	26.0	22.0	22.0	-	-
	125	-	-	-	-	41.4	41.4	41.8	35.2	28.8	25.3	21.9	21.9	21.9	-
	138	-	-	-	-	34.4	34.4	34.4	32.6	27.0	23.3	21.5	21.5	21.5	-
	151	-	-	-	-	29.2	29.2	30.3	28.8	25.0	21.6	20.1	20.1	20.1	-
	164	-	-	-	-	-	25.9	25.9	25.9	22.8	19.9	18.6	18.6	18.6	-
177	-	-	-	-	-	21.7	21.7	20.7	20.7	18.6	17.2	17.2	17.2	-	
190	-	-	-	-	-	-	19.8	18.9	17.5	16.0	14.3	14.3	14.3	-	
203	-	-	-	-	-	-	-	17.5	14.9	13.2	12.2	12.2	12.2	-	
217	-	-	-	-	-	-	-	-	13.2	13.2	11.2	11.2	11.2	-	
230	-	-	-	-	-	-	-	-	-	10.5	10.5	10.5	10.5	-	
98 ft (30 m)	39	130	121	-	-	-	-	-	-	-	-	-	-	-	
	46	126	115	94.8	-	-	-	-	-	-	-	-	-	-	
	53	110	106	92.6	77.0	63.8	-	-	-	-	-	-	-	-	
	59	94.6	94.6	89.9	75.9	63.3	-	-	-	-	-	-	-	-	
	66	81.4	82.5	85.3	74.8	62.5	51.7	-	-	-	-	-	-	-	
	72	-	72.1	76.5	72.6	61.6	51.0	41.3	-	-	-	-	-	-	
	79	-	63.3	67.1	66.8	60.7	50.6	40.3	41.3	-	-	-	-	-	
	85	-	56.1	59.4	60.2	59.0	49.5	41.3	39.6	33.6	-	-	-	-	
	92	-	-	52.8	55.0	55.0	48.4	41.3	38.8	33.0	26.4	-	-	-	
	98	-	-	49.5	49.5	49.5	46.2	38.2	38.8	31.9	26.4	20.9	-	-	
	112	-	-	-	42.4	42.4	44.8	37.4	38.2	30.8	25.5	20.9	20.9	-	-
	125	-	-	-	-	35.9	35.9	35.9	35.2	29.7	24.2	20.9	20.9	20.9	-
	138	-	-	-	-	30.8	30.8	30.3	32.5	27.7	22.6	20.0	20.0	20.0	-
	151	-	-	-	-	-	25.9	25.9	28.8	24.5	19.4	18.6	18.6	18.6	-
	164	-	-	-	-	-	-	22.8	25.9	22.6	18.0	17.1	17.1	17.1	-
177	-	-	-	-	-	-	20.0	22.8	21.0	16.9	15.8	15.8	15.8	-	
190	-	-	-	-	-	-	-	20.0	18.7	15.8	14.3	14.3	14.3	-	
203	-	-	-	-	-	-	-	17.3	17.3	14.9	13.2	13.2	13.2	-	
217	-	-	-	-	-	-	-	-	13.9	13.9	12.2	12.2	12.2	-	
230	-	-	-	-	-	-	-	-	13.1	13.1	10.5	10.5	10.5	-	
118 ft (36 m)	39	121	107	89.7	-	-	-	-	-	-	-	-	-	-	
	46	112	104	87.5	71.9	58.3	-	-	-	-	-	-	-	-	
	53	94.6	96.8	85.3	70.6	58.3	-	-	-	-	-	-	-	-	
	59	81.2	83.7	82.5	69.6	58.3	47.3	-	-	-	-	-	-	-	
	66	-	72.9	74.8	68.2	62.5	47.1	41.3	-	-	-	-	-	-	
	72	-	64.1	67.1	66.0	57.5	46.5	38.5	38.5	-	-	-	-	-	
	79	-	56.7	60.0	62.7	56.7	53.7	38.5	32.6	-	-	-	-	-	
	85	-	-	53.4	56.1	55.6	45.2	38.2	31.7	32.6	24.2	-	-	-	
	92	-	-	49.5	50.6	53.9	44.3	37.4	30.8	29.7	24.2	19.8	-	-	
	98	-	-	-	42.1	51.2	43.2	36.5	29.7	28.8	24.2	19.8	19.8	-	-
	112	-	-	-	34.5	42.1	40.4	34.4	27.3	27.3	22.1	19.8	19.8	19.8	-
	125	-	-	-	-	35.4	36.0	32.1	25.9	25.9	20.5	19.6	19.6	19.6	-
	138	-	-	-	-	30.1	30.3	28.8	24.4	24.4	19.1	18.6	18.6	18.6	-
	151	-	-	-	-	-	25.1	25.9	22.6	22.6	17.9	17.1	17.1	17.1	-
	164	-	-	-	-	-	-	22.8	21.0	21.0	16.7	15.8	15.8	15.8	-
177	-	-	-	-	-	-	20.0	18.7	18.7	14.7	14.3	14.3	14.3	-	
190	-	-	-	-	-	-	-	17.3	17.3	14.7	13.2	13.2	13.2	-	
203	-	-	-	-	-	-	-	-	13.9	13.9	12.2	12.2	12.2	-	
217	-	-	-	-	-	-	-	-	13.1	13.1	11.2	11.2	11.2	-	
230	-	-	-	-	-	-	-	-	-	10.5	10.5	10.5	10.5	-	
138 ft (42 m)	39	-	101	-	-	-	-	-	-	-	-	-	-	-	
	46	-	99.3	81.8	-	-	-	-	-	-	-	-	-	-	
	53	-	97.7	80.0	67.1	-	-	-	-	-	-	-	-	-	
	59	-	91.3	78.1	66.0	60.1	-	-	-	-	-	-	-	-	
	66	-	82.1	75.9	64.9	58.5	47.9	-	-	-	-	-	-	-	
	72	-	73.3	73.0	63.6	53.0	44.0	40.7	-	-	-	-	-	-	
	79	-	65.3	68.8	62.0	52.0	43.6	40.4	36.5	-	-	-	-	-	
	85	-	58.1	60.0	59.8	51.0	42.9	35.9	35.9	29.7	-	-	-	-	
	92	-	-	53.4	56.1	49.5	42.1	34.7	35.3	29.6	23.7	-	-	-	
	98	-	-	49.5	51.9	47.3	41.3	34.1	34.7	28.9	23.7	18.5	-	-	
	112	-	-	-	49.5	44.0	42.1	33.7	32.5	28.3	23.5	18.5	18.5	-	-
	125	-	-	-	35.0	41.9	38.9	32.5	30.9	26.7	22.0	18.5	18.5	18.5	-
	138	-	-	-	-	35.3	35.2	32.1	29.7	25.7	20.5	18.3	18.3	18.3	-
	151	-	-	-	-	30.0	30.8	28.8	26.1	24.6	19.1	17.9	17.9	17.9	-
	164	-	-	-	-	-	26.1	25.9	22.6	22.6	17.9	17.1	17.1	17.1	-
177	-	-	-	-	-	23.4	22.8	21.0	21.0	16.7	15.8	15.8	15.8	-	
190	-	-	-	-	-	-	20.0	18.7	18.7	14.7	14.3	14.3	14.3	-	
203	-	-	-	-	-	-	-	17.3	17.3	14.7	13.2	13.2	13.2	-	
217	-	-	-	-	-	-	-	-	13.9	13.9	12.2	12.2	12.2	-	
230	-	-	-	-	-	-	-	-	13.1	13.1	11.2	11.2	11.2	-	
157 ft (48 m)	39	-	89.1	-	-	-	-	-	-	-	-	-	-	-	
	46	-	87.5	73.7	-	-	-	-	-	-	-	-	-	-	
	53	-	85.5	71.9	60.1	-	-	-	-	-	-	-	-	-	
	59	-	83.1	68.3	58.5	47.9	-	-	-	-	-	-	-	-	
	66	-	80.1	67.1	57.0	47.4	40.7	-	-	-	-	-	-	-	
	72	-	73.3	64.9	55.4	46.6	40.4	34.1	-	-	-	-	-	-	
	79	-	65.3	62.4	53.7	46.0	40.1	33.9	38.5	28.6	-	-	-	-	
	85	-	58.9	58.9	51.9	45.0	39.8	33.7	33.7	28.3	21.6	-	-	-	
	92	-	-	53.4	50.1	44.0	39.4	33.4	33.4	27.9	21.6	17.2	-	-	
	98	-	-	49.5	47.9	42.9	38.8	33.2	33.2	27.6	21.6	17.2	17.2	-	-
	112	-	-	-	41.8	42.9	38.2	33.0	33.0	27.3	21.6	17.2	17.2	17.2	-
	125	-	-	-	34.9	39.6	36.3	32.1	32.1	26.6	21.3	17.			



Hook Blocks

Number of Sheaves	Capacity	Weight	"B"
16	440 tons (400 t)	12.257 lbs. (5560 kg)	11 ft. (3.50 m)
13	330 tons (300 t)	9.094 lbs. (4125 kg)	10 ft. (3.20 m)
6	120 tons (110 t)	4.938 lbs. (2240 kg)	8 ft. (2.50 m)
1	35 tons (32 t)	2.557 lbs. (1160 kg)	6 ft. (2.00 m)

Subject to change without notice

Printed in West-Germany

Mannesmann Demag Corporation

Construction Machinery Division

Chicago: 1100, Jorie Blvd., Oak Brook, Ill. 60521

Tel.: 312-920-9700, **Telex:** 28-3432

DEMAG TC-2000S

SUPERLIFT

750 ton LOAD MOMENT CHART

(13,500 foot-tons)

Superlift Attachment for DEMAG Model TC 2000S Crane

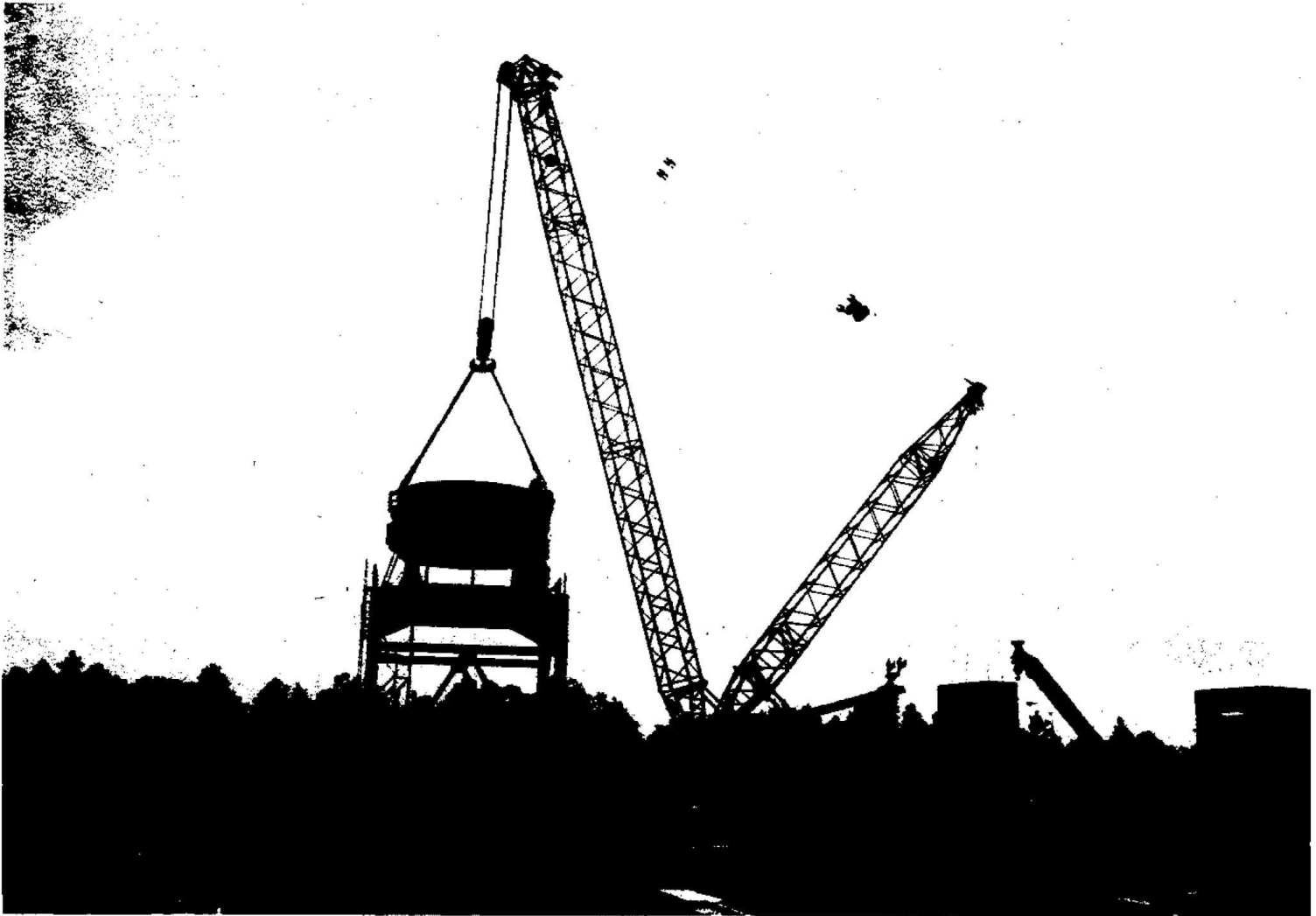

DEMAG

Baummaschinen

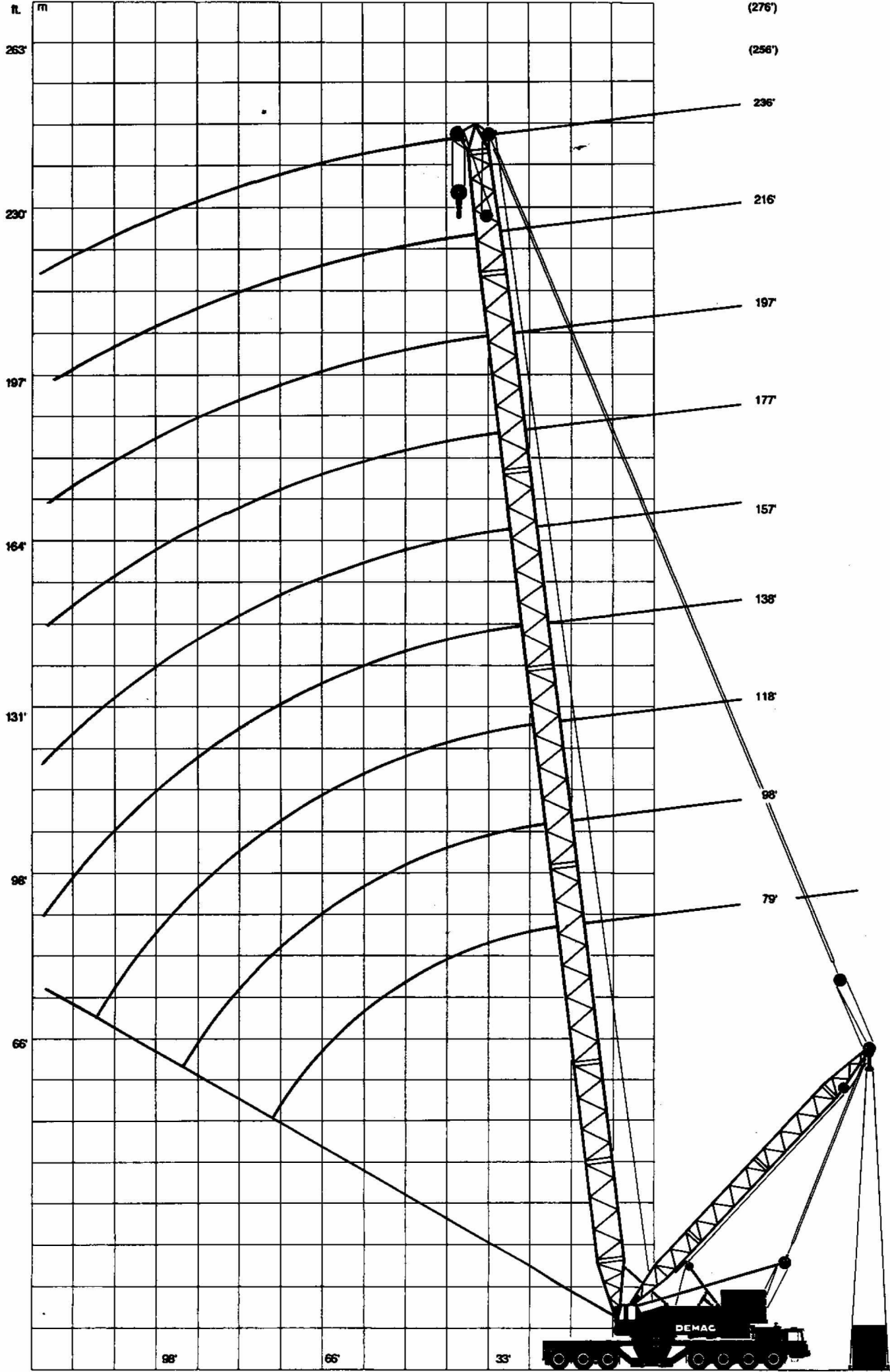

DEMAG TC-2000S SUPERLIFT I

750 ton LOAD MOMENT CHART, 1 of 3, (SL II See Chart 3 of 3)

On 45'-11" x 45'-11" Outriggers, 360° Swing, 75% Ratings, Lifting Capacities (ton=2000#) on main Boom

Main Boom	Radius	SuperLift Counterweight (tons)								
		0	44	77	110	143	160	176	193	210
ft.	ft.	tons	tons	tons	tons	tons	tons	tons	tons	tons
79' ^a with Heavy Duty Hammer Head	30'	241.45	280.04	314.21	347.29	385.88				
	33'	214.99	253.58	283.34	314.21	345.08				
	40'	175.30	208.37	238.14	263.50	288.86				
	46'	148.84	176.40	202.86	226.01	249.17				
	53'	127.89	153.25	175.30	198.45	218.30				
	59'	112.46	134.51	154.35	175.30	194.04				
	66'	100.33	120.17	137.81	156.56	174.20				
	72'	90.41	108.05	124.58	141.12	154.35				
79' ^a with Std. Hammer Head	30'	241.45	280.04	314.21	330.75					
	33'	214.99	253.58	283.34	314.21	330.75				
	40'	175.30	208.37	238.14	263.50	288.86	302.09	315.32		
	46'	148.84	176.40	202.86	226.01	249.17	260.19	271.22		
	53'	127.89	153.25	175.30	198.45	218.30	228.22	237.04		
	59'	112.46	134.51	154.35	175.30	194.04	202.86	211.68		
	66'	100.33	120.17	137.81	156.56	174.20	180.81			
	72'	90.41	108.05	124.58	141.12	154.35				
98' ^a	30'	239.24	277.83	310.91	319.73					
	33'	212.78	250.27	281.14	312.01	319.73				
	40'	174.20	206.17	234.83	260.19	286.65	298.78	312.01		
	46'	145.53	174.20	200.66	223.81	245.86	256.88	267.91	278.93	
	53'	126.79	149.94	173.09	196.25	214.99	224.91	234.83	244.76	254.68
	59'	111.35	132.30	152.15	173.09	190.73	199.55	209.48	217.19	226.01
	66'	99.23	117.97	135.61	154.35	171.99	179.71	187.43	195.14	203.96
	72'	89.30	105.84	122.38	138.92	155.45	163.17	169.79	177.50	184.12
	79'	81.59	95.92	111.35	126.74	141.12	148.84	155.45	162.07	
	85'	72.77	88.20	101.43	115.76	130.10	136.71	143.33		
	92'	67.25	81.59	93.71	106.94	120.17	126.79			
	98'	61.74	74.97	87.10	99.23	110.25	115.76	122.38	126.79	
118' ^a	30'	222.71	275.63	286.65						
	33'	207.27	250.27	281.14	286.65					
	40'	173.09	206.17	234.83	260.19	286.65				
	46'	144.43	174.20	200.66	223.81	245.86	253.58	264.60		
	53'	125.69	149.94	173.09	196.25	214.99	222.71	231.53	242.55	
	59'	110.25	132.30	152.15	171.99	190.73	199.55	209.48	216.09	226.01
	66'	98.12	117.97	135.61	154.35	171.99	178.61	187.43	195.14	203.96
	72'	88.20	105.84	121.28	138.92	154.35	160.97	168.68	176.40	184.12
	79'	79.38	95.92	111.35	126.79	141.12	147.74	154.35	162.07	168.68
	85'	72.77	88.20	101.43	115.76	128.99	135.61	143.33	149.94	155.45
	92'	67.25	81.59	93.71	106.94	120.17	125.69	132.30	138.92	143.33
	98'	61.74	74.97	87.10	99.23	110.25	115.76	122.38	126.79	
138' ^a	30'	224.91	248.06							
	33'	199.55	248.06							
	40'	171.99	207.27	232.63	248.06					
	46'	144.43	171.99	198.45	221.60	243.65				
	53'	124.58	147.74	170.89	194.04	212.78	222.71	232.63	242.55	
	59'	109.15	130.10	149.94	170.89	189.63	197.35	206.17	214.99	220.50
	66'	97.02	115.76	133.40	152.15	169.79	177.50	185.22	192.94	201.76
	72'	87.10	103.64	120.17	136.71	153.25	160.97	168.68	175.30	183.02
	79'	79.38	93.71	107.15	124.58	140.02	146.63	153.25	159.86	167.58
	85'	71.66	86.00	99.23	113.56	124.58	134.51	141.12	147.74	153.25
	92'	66.15	79.38	91.51	104.74	117.97	124.58	131.20	136.71	142.22
	98'	60.64	72.77	84.89	97.02	109.15	114.66	121.28	126.79	132.30
	110'	51.82	62.84	73.87	83.79	94.82	100.33	105.84	111.35	115.76
125'	45.20	55.13	65.05	73.87	83.79	88.20	93.71	97.02		
157' ^a	30'	209.48								
	33'	198.45	209.48							
	40'	169.79	207.27							
	46'	144.43	171.99	198.45	207.27					
	53'	124.58	146.63	170.89	192.94	206.17				
	59'	110.25	130.10	149.94	170.89	189.63	197.35	206.17		
	66'	98.12	114.66	131.20	151.04	168.68	177.50	184.12	192.94	198.45
	72'	87.10	103.64	120.17	136.71	153.25	160.97	168.68	175.30	183.02
	79'	78.28	93.71	109.15	123.48	137.81	146.63	153.25	159.86	166.48
	85'	71.66	86.00	99.23	113.56	124.58	134.51	141.12	147.74	153.25
	92'	65.05	78.28	91.51	103.64	116.87	123.48	130.10	136.71	141.12
	98'	59.54	72.77	84.89	97.02	109.15	114.66	121.28	126.79	132.30
	110'	51.82	62.84	73.87	83.79	94.82	100.33	105.84	111.35	115.76
125'	44.10	55.13	65.05	73.87	83.79	88.20	93.71	98.12	102.53	
140'	38.59	49.61	57.33	66.15	74.97	79.38	83.79	88.20		
177' ^b	33'	180.81								
	40'	160.97	179.71							
	46'	137.81	169.79	178.61						
	53'	122.38	146.63	169.79	177.50					
	59'	108.05	127.89	148.84	168.68	176.40				
	66'	94.82	113.56	132.30	149.94	167.58				
	72'	84.89	102.53	119.07	135.61	152.15				
	79'	77.18	92.61	106.94	123.48	137.81				
	85'	70.56	83.79	98.12	112.46	125.69				
	92'	63.95	77.18	90.41	102.53	115.76				
	98'	59.54	71.66	82.69	94.82	103.64				
	110'	50.72	61.74	71.66	82.69	88.20				
	125'	44.10	54.02	62.84	71.66	74.97				
140'	38.59	47.41	56.23	61.74	65.05					
150'	34.18	41.90	50.72	54.02	57.33					

a - Mast length = 79'0" Mast radius = 42'8"
 b - Mast length = 118'0" Mast radius = 42'8"
 c - Mast length = 118'0" Mast radius = 52'6"

DEMAG TC-2000S SUPERLIFT I

750 ton LOAD MOMENT CHART, 2 of 3, (SL II, See Chart 3 of 3)

On 45'-11" x 45'-11" Outriggers, 360° Swing, 75% Ratings, Lifting Capacities (ton=2000#) on main Boom

Main Boom	Radius	SuperLift Counterweight (tons)								
		0	44	77	110	143	160	176	193	210
ft.	ft.	tons	tons	tons	tons	tons	tons	tons	tons	tons
197 ^b	33'	145.53	148.84							
	40'	135.61	147.74							
	46'	125.69	146.63							
	53'	117.47	143.33	145.53						
	59'	106.94	127.89	144.43						
	66'	94.82	113.56	132.30	143.33					
	72'	84.89	102.53	119.07	135.61	142.22				
	79'	76.07	91.51	106.94	123.48	137.81				
	85'	69.46	83.79	98.12	112.46	125.69				
	92'	62.84	77.18	89.30	102.53	115.76				
	98'	58.43	71.66	82.69	94.82	106.94				
	110'	48.51	61.74	71.66	82.69	90.41				
	125'	43.00	54.02	62.84	72.77	78.28				
	140'	37.49	47.41	56.23	63.95	68.36				
	150'	33.08	41.90	50.72	56.23	59.54				
	165'	28.67	38.59	44.10	49.61	51.82				
	180'	25.36	35.28	39.69	43.00	46.31				
216 ^b	33'	121.28								
	40'	121.28								
	46'	120.17								
	53'	114.66	120.17							
	59'	100.33	120.17							
	66'	88.20	112.46	120.17						
	72'	79.38	100.33	116.87	120.17					
	79'	72.77	91.51	105.84	120.17					
	85'	66.15	82.69	97.02	110.25	120.17				
	92'	61.74	76.07	88.20	101.43	114.66				
	98'	56.23	69.46	81.59	93.71	105.84				
	110'	47.41	59.54	70.56	81.59	91.51				
	125'	40.79	51.82	61.74	70.56	80.48				
	140'	35.28	45.20	55.13	62.84	71.66				
	150'	30.87	40.79	48.51	56.23	63.95				
	165'	27.56	36.38	44.10	50.72	58.43				
	180'	24.26	33.08	39.69	45.20					
190'	22.05	29.77	36.38	39.69						
236 ^b	33'	101.43								
	40'	101.43								
	46'	100.33								
	53'	100.33								
	59'	98.12	100.33							
	66'	88.20	99.23							
	72'	79.38	99.23							
	79'	70.56	90.41	99.23						
	85'	62.84	82.69	97.02	99.23					
	92'	57.33	74.97	88.20	98.12					
	98'	52.92	69.46	81.59	92.61	98.12				
	110'	46.31	58.43	70.56	79.38	91.51				
	125'	39.69	50.72	61.74	69.46	79.38				
	140'	35.28	45.20	54.02	61.74	70.56				
	150'	30.87	40.79	47.41	56.23	62.84				
	165'	26.46	36.38	43.00	49.61	55.13				
	180'	24.26	33.08	39.69	45.20	49.61				
190'	20.95	29.77	35.28	39.69	44.10					
205'	18.74	27.56	33.08	36.38	39.69					
256 ^b	40'	86.00								
	46'	84.89								
	53'	83.79								
	59'	83.79								
	66'	82.69								
	72'	77.18	81.59							
	79'	66.15	81.59							
	85'	57.33	80.48							
	92'	52.92	74.97	80.48						
	98'	48.51	68.36	79.38						
	110'	40.79	57.33	69.46	77.18					
	125'	35.28	49.61	60.64	69.46	72.77				
	140'	30.87	44.10	52.92	61.74	68.36				
	150'	27.56	39.69	47.41	56.23	62.84				
	165'	24.26	35.28	41.90	49.61	55.13				
	180'	20.95	31.97	38.59	45.20	49.61				
	190'	18.74	28.67	34.18	39.69	44.10				
205'	17.64	25.36	31.97	36.38	39.69					
220'	14.33	23.15	28.67	33.08	36.38					
230'	12.13	20.95	26.46	29.77	33.08					
276 ^b	40'	69.46								
	46'	69.46								
	53'	69.46								
	59'	69.46								
	66'	69.46								
	72'	69.46								
	79'	66.15	69.46							
	85'	57.33	69.46							
	92'	52.92	68.36							
	98'	48.51	67.25							
	110'	40.79	57.33	65.05						
	125'	35.28	49.61	60.64						
	140'	30.87	44.10	52.92	57.33					
	150'	27.56	39.69	47.41	54.02					
	165'	23.15	35.28	41.90	48.51					
	180'	19.85	31.97	38.59	45.20					
	190'	17.64	28.67	34.18	39.69					
205'	15.44	25.36	31.97	36.38						
220'	13.23	23.15	28.67	33.08						
230'	12.13	20.95	26.46	29.77						
256'	11.03	19.85	24.26	27.56						

a - Mast length = 79'0" Mast radius = 42'8"

b - Mast length = 118'0" Mast radius = 42'8"

c - Mast length = 118'0" Mast radius = 52'6"

DEMAG TC-2000S SUPERLIFT II

750 ton LOAD MOMENT CHART, 3 OF 3, (SL I, See Charts 1 & 2 of 3)

On 45'-11" x 45'-11" Outriggers, 360° Swing, 75% Ratings, Lifting Capacities (ton=2000#) on main Boom

Main Boom	Radius	SuperLift Counterweight (tons)								
		0	44	77	110	143	160	176	193	210
ft.	ft.	tons	* tons	tons	tons	tons	tons	tons	tons	tons
157 ^c	30'	214.99								
	33'	213.89	214.99							
	40'	174.20	214.99	217.19						
	46'	146.63	189.63	217.19	220.50					
	53'	125.69	163.17	191.84	217.19	220.50				
	59'	109.15	143.33	168.68	192.94	214.99	220.50	220.50		
	66'	97.02	126.79	149.94	171.99	192.94	202.86	212.78	220.50	
	72'	87.10	113.56	134.51	155.45	174.20	183.02	192.94	201.76	
	79'	78.28 ¹	103.64	122.38	141.12	159.86	167.58	176.40	184.12	
	85'	71.66 ²	93.71	111.35	128.99	145.53	154.35	162.07	169.79	
	92'	65.05 ²	86.00	102.53	119.07	134.51	142.22	149.94	156.56	
	98'	60.64 ³	79.38	94.82	110.25	124.58	132.30	138.92	145.53	
	110'	51.82 ³	69.46	82.69	94.82	108.05	114.66	121.28	127.89	
	125'	45.20 ³	60.64	72.77	83.79	95.92	101.43	108.05	112.46	
140'	38.59 ²	54.02	65.05	74.97	86.00	91.51	93.71			
177 ^{c*}	33'	180.81								
	40'	162.07	180.81							
	46'	143.33	167.58	178.61						
	53'	123.48	154.35	169.79	177.50					
	59'	108.05	141.12	157.66	168.68	176.40				
	66'	95.92	125.69	147.74	159.86	169.79	184.12			
	72'	84.89	112.46	132.30	152.15	162.07	166.48	170.89	169.79	
	79'	76.07	101.43	120.17	138.92	155.45	158.76	164.27	163.17	
	85'	68.36	92.61	110.25	126.79	144.43	151.04	156.56	153.25	
	92'	61.74	84.89	101.43	116.87	132.30	140.02	146.63	144.43	
	98'	56.23	78.28	92.61	108.05	122.38	128.99	137.81	125.69	
	110'	47.41	67.25	80.48	94.82	106.94	112.46	120.17	111.35	
	125'	40.79	58.43	70.56	81.59	93.71	99.23	105.84	99.23	
	140'	35.28	51.82	62.84	72.77	83.79	88.20	94.82	89.30	
150'	29.77	46.31	56.23	66.15	74.97	79.38	84.89			
197 ^c	33'	143.33								
	40'	143.33	145.53							
	46'	143.33	145.53							
	53'	123.48	145.53	147.74						
	59'	108.05	141.12	147.74						
	66'	95.92	125.69	147.74	148.84					
	72'	84.89	112.46	132.30	148.84	151.04				
	79'	77.18 ¹	101.43	120.17	138.92	151.04	151.04			
	85'	69.46 ¹	92.61	110.25	126.79	144.43	151.04	151.04		
	92'	63.95 ²	84.89	100.33	116.87	132.30	140.02	147.74	151.04	
	98'	58.43 ²	78.28	92.61	108.05	122.38	128.99	137.81	144.43	
	110'	49.61 ²	67.25	80.48	93.71	106.94	112.46	120.17	125.69	
	125'	43.00 ²	58.43	70.56	81.59	93.71	99.23	105.84	111.35	
	140'	37.49 ²	51.82	62.84	72.77	83.79	88.20	94.82	99.23	
150'	33.08 ³	46.31	56.23	66.15	74.97	79.38	84.89	89.30		
165'	28.67 ²	41.90	50.72	59.54	68.36	71.66	77.18	81.59		
180'	25.36 [*]	37.49 [*]	46.31 [*]	54.02 [*]	62.84 [*]	65.05 [*]	70.56 [*]			
236 ^c	33'	101.43								
	40'	101.43								
	46'	101.43								
	53'	101.43								
	59'	101.43	102.53							
	66'	93.71	102.53							
	72'	83.79	102.53	104.74						
	79'	74.97	100.33	104.74						
	85'	68.36 ¹	90.41	104.74	104.74					
	92'	61.74 ¹	82.69	99.23	104.74					
	98'	57.33 ²	76.07	91.51	104.74	104.74				
	110'	48.51 ²	65.05	78.28	91.51	104.74	104.74			
	125'	41.90 ²	57.33	68.36	80.48	92.61	98.12	103.64		
	140'	36.38 ³	50.72	60.64	71.66	81.59	87.10	92.61		
150'	30.87 ²	44.10	54.02	63.95	73.87	78.28	82.69			
165'	27.56 ³	39.69	48.51	57.33	66.15	70.56	74.97			
180'	23.15 ²	36.38	44.10	51.82	60.64	65.05	68.36			
190'	20.95 ²	31.97	39.69	47.41	55.13	59.54	62.84			
205'	18.74 [*]	29.77 [*]	36.38 [*]	44.10 [*]	50.72 [*]	55.13 [*]	58.43 [*]			
256 ^c	40'	86.00								
	46'	86.00								
	53'	86.00								
	59'	86.00								
	66'	86.00								
	72'	82.69	87.10							
	79'	73.87	87.10							
	85'	67.25	87.10							
	92'	60.64 ¹	82.69	88.20						
	98'	56.23 ²	76.07	88.20	88.20					
	110'	47.41 ²	65.05	78.28	88.20	88.20				
	125'	40.79 ³	56.23	68.36	79.38	88.20				
	140'	35.28 ³	49.61	59.54	70.56	79.38				
	150'	30.87 ²	44.10	52.92	62.84	71.66				
165'	26.46 ²	38.59	47.41	56.23	65.05					
180'	23.15 ²	35.28	43.00	51.82	59.54					
190'	19.85 ²	31.97	38.59	46.31	54.02					
205'	17.64 ²	28.67	35.28	43.00	49.61					
220'	15.44 ²	26.46	33.08	39.69	46.31					
230'	13.23 [*]	24.26 [*]	29.77 [*]	36.38 [*]	40.79 [*]					

a - Mast length = 79'0" Mast radius = 42'8"
 b - Mast length = 118'0" Mast radius = 42'8"
 c - Mast length = 118'0" Mast radius = 52'6"

* - Extended Pendant Wires Only.

1 - Extended Pendant Wires, (Standard Pendant Wires = 1.10 Ton Less).
 2 - Extended Pendant Wires, (Standard Pendant Wires = 2.21 Ton Less).
 3 - Extended Pendant Wires, (Standard Pendant Wires = 0.11 Ton Less).

SUPERLIFT Attachment for the DEMAG TC-2000S Truck Crane

For applications where load moments in excess of 7920 foot-tons are encountered, the DEMAG TC-2000S Truck Crane can be equipped with a Superlift Attachment which permits load moments up to 13500 foot-tons. An increase of 170%, resulting in a 750 ton load moment chart at an 18' radius, up to an increase of 300% with 256' of main boom at a 203' radius. The performance benefits derived from the Superlift result from the fact that a heavier load is compensated by a corresponding counterweight. This causes the loads on the structural member of the crane, such as superstructure, slewing ring, undercarriage, and outriggers, to be applied centrally while relieving the boom assembly.

The additional counterweight is automatically lifted off the ground when attempting to pick up a load with the Superlift, so that the upper can be swung as desired. The Superlift Attachment consists of the following components which are readily mounted to our standard crane without major modifications:

- (a) Superlift Mast with head sheaves
- (b) Superlift Backstops
- (c) Counterweight Suspension Cables
- (d) Boom-Hoist Bridle
- (e) Additional Counterweight
- (f) Additional Hydraulic and Electric Controls
- (g) Conversion Parts to Overload Cut-Out

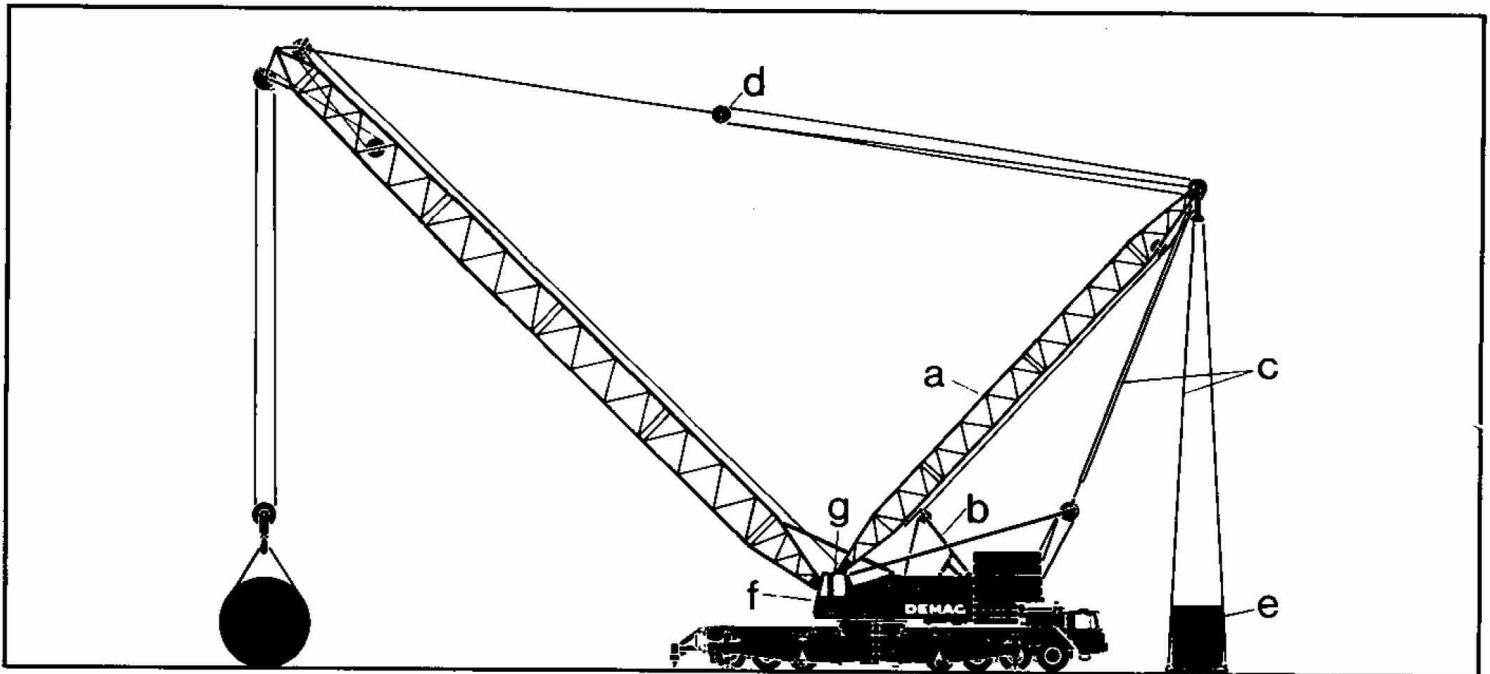

Subject to change without notice

DEMAG Baumaschinen

Zweigniederlassung der
Demag Aktiengesellschaft

Postfach 180180
BuscherhofstraBe 10
4000 Dusseldorf 13
Telefon: (0211) 71091
Telex: 08 582 703

Niederlassungen:

Hamburg, Tel. (040) 670 1043
Hannover (Lehrte), Tel. (05132) 4081
Berlin, Tel. (030) 8 52 40 31
Essen, Tel. (0201) 4 00 11
Frankfurt (Maintal 1), Tel. (06181) 4 50 11
Bierbach, Tel. (0 68 42) 30 11
Munche, Tel. (0 89) 3 51 30 91

Vertragshandler:

Lingener Baumaschinen GmbH & Co. KG
Lingen/Ems, Tel. (05 91) 4273

O. Sponsel & Co.
Bamberg, Tel. (09 51) 2 51 41
Nurnberg, Tel. (09 11) 30 10 05

Gebr. Hones GmbH
Munchingen, Tel. (0 71 50) 60 18
Krauchenwies, Tel. (0 75 76) 5 50