

- 7000 - 21000 kg
- 9400 - 10200 mm
- 93 kW (127 HP) - 146 kW (196 HP) at 2200 rpm



Telescopic Handlers | Product Range



Multipurpose fleet

■ The Doosan High Capacity Telescopic Handlers offer exceptional performance in terms of heavy lifting.

The product range opens doors to numerous applications all in one versatile machine; from civil engineering to forestry, mining to ports... the possibilities are endless. An unmatched attention to detail guarantees optimum reliability and reduced maintenance costs.

■ Combining the reach of cranes, the power of wheel loaders and the efficiency of forklift trucks

HANDLING, MORE THAN A CRANE

With the range of attachments which a typical crane or a forklift cannot use, the Doosan HC Telescopic Handlers allow you to reach the versatility and performance not possible by a single machine before. All this, together with compact dimensions and efficiency!



1



LIFTING, MORE THAN A FORKLIFT

Combine the versatility of a telescopic machine with the efficiency and manoeuvrability of a forklift. This combination offers unmatched capabilities for handling large loads up to 21 ton while maintaining the agility of a small forklift truck.

2



LOADING, MORE THAN A WHEEL LOADER

With buckets up to 4.5 m³ in capacity, a 10 meter reach, a lift capacity up to 21 ton, as well as a vast range of attachments, you have one machine that can tackle the job of any wheel loader.

3

High mobility and reach



■ Do the job faster and more efficiently with the features of multiple machines combined into 1:

- Reach of 10 meters and load capacity up to 21 t ①
- Rough terrain access ②
- High travel speed up to 36 km/h ③
- Compact dimensions ④

Power meeting comfort

■ Spacious cab

Lift 21 ton with fingertip control. With Doosan High Capacity Telescopic Handlers, control and capacity are both fully optimized for performance. The cab offers the operator a fully integrated, comfortable work space designed to provide both efficiency and productivity.

- The controls are logically designed and positioned within arm reach.
- A spacious glazed cab offers excellent panoramic visibility for easier operation and better safety.
- An easy-to-use load control system ensures the operator can focus completely on the task at hand.



Experience versatility

■ Do any job...

... thanks to our large range of attachments:

1

A CRANE



EXTENSION JIB +
HYDRAULIC WINCH



EXTENSION JIB + HOOK



HYDRAULIC WINCH



HOOK

2

A WHEEL LOADER



LIGHT MATERIAL BUCKET



DIGGING BUCKET

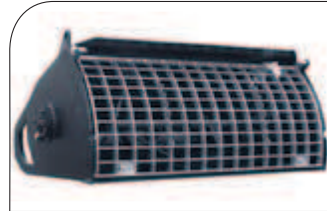

MIXING BUCKET



CONCRETE BUCKET

3

A FORKLIFT



PALLET FORK TEETH



HYDRAULIC PALLET FORKS



PALLET FORK EXTENSIONS

Serviceability is excellent, with easy access to all [maintenance points](#). All areas have been carefully designed for ease of inspection, maintenance and repair. Service intervals for various components have been extended to [reduce costs](#) for the customer and increase machine utilization.





Telescopic Handlers Specifications

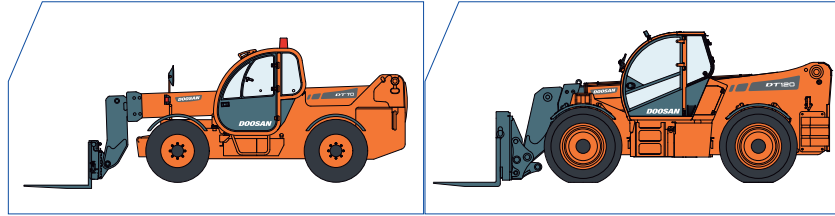

Model		DT70	DT120
PERFORMANCE			
Maximum lift capacity	kg	7000	12000
Maximum lift height	mm	9650	9400
Maximum forward reach	mm	5400	4900
Lift capacity at full height	kg	5000 *	7000
Lift capacity at full reach	kg	2500 *	3000
Breakout force	daN	5700	11400
Standard bucket capacity	m ³	0.9	3.0
WEIGHT			
Weight (unladen)	kg	11300	16700
ENGINE			
Make / Model		Iveco NEF-TA	Perkins 1104D-ETA
Fuel / Cooling		Diesel / Liquid	Diesel / Liquid
Rated power at 2200 RPM	kW (HP)	93 (127)	106 (144)
Number of cylinders		4	4
Displacement	cm ³	4485	4399
TRACTION			
Standard tyres		18/22.5" - R20	16.00 R25 XLB
Low speed (forward/reverse)	km/h	10	11
High speed (forward/reverse)	km/h	30	28
Transmission		Hydrostatic	Hydrostatic
HYDRAULIC SYSTEM			
Pump type		Gear pump	Gear pump with LS valve
Distributor		On/Off Proportional flow sharing	Flow sharing
Combined pump capacity	l/min	135	160
Working pressure	bar	230	280 **
BRAKES			
Service brake		Oil-immersed disc on 4 wheels	Oil-immersed disc on 4 wheels
Parking and emergency brake		Negative brake with hydraulic command	Negative brake with hydraulic command
DIMENSIONS			
Overall width	mm	2360 ***	2400
Overall length (with carriage)	mm	5910	6395
Overall height	mm	2490	2870
Wheelbase	mm	2950	3350
External turning radius (at tyres)	mm	4400	4850
Internal turning radius	mm	1700	1800

* On stabilizers - ** Maximum pressure with variable pump - *** On tyres

3 steering modes

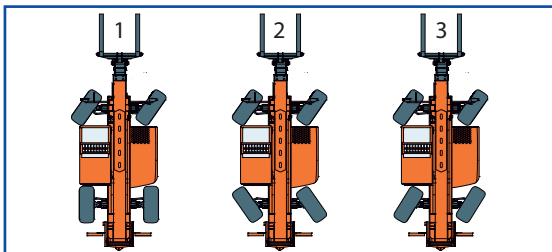

Exceptional manoeuvrability

Whatever your working environment, there is a steering mode to suit your requirement:

1. Front-wheel steering for road travel; gets you to your next site quickly.
2. All-wheel steering gives you better on-site handling and a smaller turning radius, for sharp turns in small and narrow spaces.
3. Crab steering lets you position loads to the side with perfect precision in cramped areas.

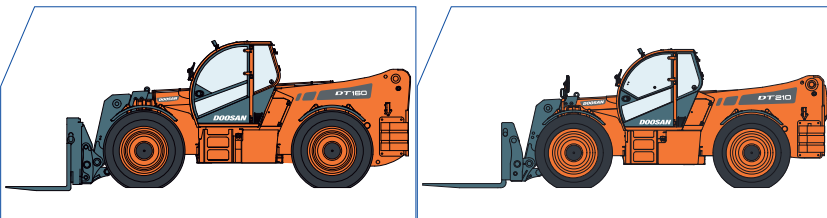

DT160	DT210
16000	21000
10200	10200
5150	5100
11000	14500
5000	7000
16200	18900
3.5	3.5
23700	27400
Perkins 1106D-ETA	Perkins 1106D-ETA
Diesel / Liquid	Diesel / Liquid
146 (196)	146 (196)
6	6
6598	6598
18.00 R25 XLB	23.5 R25 XMA
10	9
25	25
Hydrostatic	Hydrostatic
Gear pump with LS valve	Gear pump with LS valve
Flow sharing	Flow sharing
170	170
350 **	350 **
Oil-immersed disc on 4 wheels	Oil-immersed disc on 4 wheels
Negative brake with hydraulic command	Negative brake with hydraulic command
2500	2720
6775	6950
2870	2890
3700	3700
5550	5550
2650	2650

Levelling

Frame levelling for better handling on uneven ground and precise positioning.



Load charts

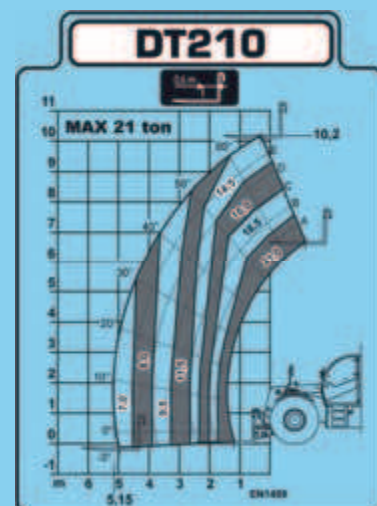
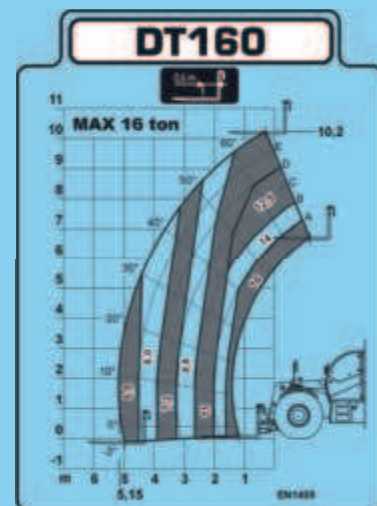
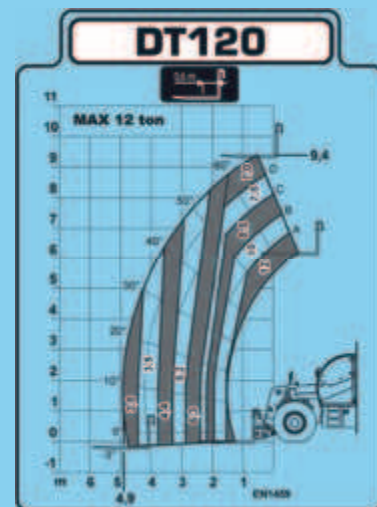
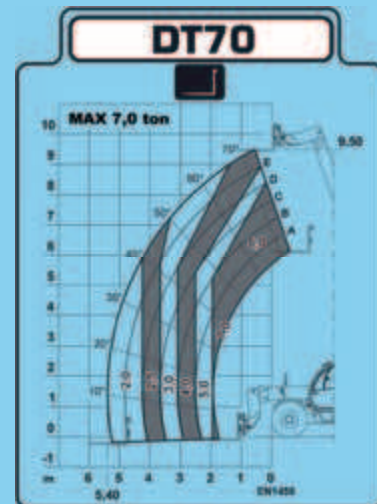

Options and Attachments

Model	DT70	DT120	DT160	DT210
OPTIONS				
Sun visor	STD	STD	STD	STD
4 Lights on top of the cab	STD	STD	STD	STD
Quick coupler hydraulically controlled	x	x	x	x
Air conditioning	x	x	x	x
Additional hydraulic line (with electrical cable)	x	x	x	x
Front cab protection grill	x	x	x	x
Air suspension seat	x	x	x	x
Mixing bucket pre-installation (electrical connector)	x	x	x	x
Cold weather pre-installation	x	x	x	x
Boom light	x	x	x	x
Radio with CD player	x	x	x	x
Catalytic exhaust purifier	x	x	x	x
Particle filter	x	x	x	x
Particle filter + catalytic exhaust purifier		x	x	x
Special paint	x	x	x	x
Road homologation		x	x	x
Reversible fan		x	x	x
Solid tyres 22.5" R20	x			
Solid tyres 16" R25		x		
Solid tyres 18" R25			x	
Solid tyres 23.5" R25				x
Stabilizers	x			
Frame levelling	x	STD	STD	STD
Lifting accessories pre-installation	x	STD	STD	STD
Man-platform pre-installation	x	STD	STD	STD
Centering handler pre-installation	STD	STD	STD	STD
ATTACHMENTS				
Pallet fork teeth (set of 2, 200x60 mm L=1200, 7 t)	x			
Hydraulic pallet forks	x			
Pallet fork teeth (set of 2, 200x70 mm, L=1200 / 1800 or 2400, 12 t)		x		
Hydraulic pallet forks (with set of 2 forks 200x70 mm, L=1200 / 1800 or 2400, 12 t)		x		
Pallet fork teeth (set of 2, 200x80 mm, L=1200 / 1800 or 2400, 16 t)			x	
Hydraulic pallet forks (with set of 2 forks 200x80 mm, L=1200 / 1800 or 2400, 16 t)			x	
Pallet fork teeth (set of 2, 200x95 mm, L=1800 or 2400, 20 t)				x
Hydraulic pallet forks (with set of 2 forks 200x95 mm, L=1800 or 2400, 21 t)				x
Hook for fork carriage	x	x	x	x
Concrete bucket (400 l - with hydraulic opening)	x			
Concrete bucket (600 l - with hydraulic opening)	x			
Extension jib with winch (2.0 t, L=1.3m)	x			
Extension jib with winch (1.2t, L=2.5m)	x			
Extension jib with hook (1.2 t, L=2.5 m)	x			
Extension jib with hook (6.0 t, L=2.5 m)		x	x	x
Hydraulic winch (double pull with cable guide - 3.8 t)	x			
Hydraulic winch (double pull with cable guide - 5.0 t)	x			
Hydraulic winch (double pull with cable guide - 8.0 t)		x	x	x
Hydraulic winch (double pull with cable guide - 12.0 t)		x	x	x
Light material bucket (width 2.35 m, 1.0 m ³)	x			
Light material bucket (width 2.35 m, 1.5 m ³)	x			
Light material bucket (width 2.35 m, 2.0 m ³)	x			
Light material bucket (width 3.0 m, 4.5 m ³)		x	x	x
Digging bucket with teeth (width 2.35 m, 0.9 m ³)	x			
Digging bucket without teeth (width 2.35 m, 0.9 m ³)	x			
Digging bucket without teeth (width 2.5 m, 3.0 m ³)		x	x	
Digging bucket without teeth (width 2.8 m, 3.5 m ³)				x
Mixing bucket (500 l)	x			
Mixing bucket (1500 l)		x	x	x
Centering handler (used to mount beams in tunnels - option pre-installation is required)	x	x	x	x

Specifications and design are subject to change without notice. Pictures of Doosan products may show other than standard equipment.



Doosan Infracore
Construction Equipment

