

DOOSAN

Reduced Tail Swing

CRAWLER EXCAVATORS

DX140LCR-3	15 200 kg	33,510 lb.	109 hp (81 kW)
DX235LCR	24 300 kg	53,575 lb.	173 hp (129 kW)

14 – 24 METRIC TON



Who is Doosan?

Founded in 1896, Doosan is a strong, stable and global company with a long legacy in infrastructure support. Its history in equipment manufacturing began in 1937. Since 2005, we've grown to become the fifth largest construction equipment manufacturer in the world.

From our design concepts to manufacturing in our ISO-certified factories, Doosan machines are built for profit-making productivity and an unequalled ownership experience. And we provide high-performance service to match our high-powered equipment.

Our Customer Commitment

Doosan is committed to helping you be more productive. Our long-standing reputation for quality equipment, parts and product support instills customer confidence because everything we do is done with our customer in mind.

With Doosan Elite PLUS™, we take our customer commitment one step further by offering a full selection of product support solutions that help increase productivity, decrease downtime and improve your bottom line.

Doosan Elite PLUS™, our comprehensive product support program, is designed to protect and enhance resale value while helping you control costs. Our repair-before-failure approach allows you to manage your cash no matter what equipment you own. Doosan Elite PLUS™ offers Doosan Elite Assurance™ Warranty, Doosan GPS Program, Doosan Component Analysis Program™, and All-Makes Parts and Attachments. Each one of these valuable programs can be used separately or as a comprehensive product support system for your entire fleet.





Doosan can be found in every area of the infrastructure support business, which encompasses many facets of the heavy construction equipment industry.

Many contractors might be surprised to know that, while Doosan is a relatively young brand in the North American construction equipment market, the organization has a global manufacturing history going back more than 75 years.

Today, Doosan Infracore Construction Equipment America (DICEA) and its affiliates are industry leaders in the engineering, manufacturing and marketing of construction equipment including skid-steers, excavators, wheel loaders, articulated dump trucks, attachments, air compressors, lighting systems and generators as well as compact construction equipment and engine power systems.

Building Your Tomorrow Today

Our construction equipment group leads Doosan's infrastructure support business (ISB) segment. Other ISB businesses include:

- Forklifts & Material Handling
- Machine Tools
- Castings & Forgings
- Construction & Engineering
- Power Generation
- Water Treatment & Desalination
- Renewable Energy

Your North American Partners

Throughout our decades of selling equipment in North America, we've been building a network of dealers designed to surpass the standards for customer service. From coast to coast, there's a solid infrastructure that supports your equipment, including a parts distribution facility in Chicago and a service training facility in Georgia, sales training center in Arizona, attachments design and development in Minnesota and sales & marketing support in North Dakota.



General

— STANDARD CONFIGURATION —

	UNIT	DX140LCR-3	DX235LCR
ENGINE			
MODEL		QSB 4.5	DL06
NUMBER OF CYLINDERS		4	6
RATED POWER GROSS (HP per SAE J1995)	hp (kW) @ rpm	109 (81) @ 2200	173 (129) @ 1900
RATED POWER NET (HP per SAE J1349) NET	hp (kW) @ rpm	102 (76) @ 2200	166 (124) @ 1900
MAXIMUM TORQUE (GROSS) (SAE J1995)	ft.-lb. (Nm) @ rpm	360 (488) @ 1500	564 (765) @ 1400
PISTON DISPLACEMENT	in. ³ (cc)	275 (4500)	359 (5890)
BORE AND STROKE	in. x in. (mm x mm)	4.2 x 4.9 (107 x 124)	4 x 5 (100 x 125)
STARTER	V (kW)	24 (4.5)	24 (4.5)
BATTERIES	V (AH)	24 (100)	2 x 12 (100)
AIR CLEANER		Inlet Transition	Double Elements
HYDRAULICS			
MAIN PUMPS	gpm (L/min)	2 x 30 (2 x 114)	2 x 58 (2 x 220.2)
PILOT PUMP Gear design	gpm (L/min)	7.33 (27,75)	7.2 (27,4)
RELIEF PRESSURE (Normal/Boost)	psi (kg/cm ²)	4,694/4,978 (330/350)	569 (39)
MAXIMUM SYSTEM PRESSURE			
BOOM/ARM/BUCKET (Normal Mode)	psi (kg/cm ²)	4,694 (330)	4,978 (343)
BOOM/ARM/BUCKET (Power Mode)	psi (kg/cm ²)	4,978 (350)	5,263 (363)
TRAVEL (Normal Mode)	psi (kg/cm ²)	4,694 (330)	4,978 (343)
TRAVEL (Power Mode)	psi (kg/cm ²)	4,978 (350)	5,263 (363)
SWING (Normal Mode)	psi (kg/cm ²)	4,694 (330)	4,267 (294)
SWING (Power Mode)	psi (kg/cm ²)	4,978 (350)	5,263 (363)
UNDERCARRIAGE			
UPPER ROLLERS		1	2
LOWER ROLLERS		7	9
NUMBER OF SHOES (Links per Side)		46	49
TOTAL LENGTH OF TRACK	ft. in. (mm)	12' 4" (3755)	14' 7" (4445)
ENVIRONMENT			
SOUND LEVEL (2000/14/EC)	dB(A)	101	103
CABIN SOUND LEVEL (ISO 6396)	dB(A)	72	71
SWING MECHANISM			
SWING SPEED	rpm	11.4	11.3
SWING TORQUE	lbf.-ft. (kgf-m)	34,681 (4795)	52,442 (7250)
DRIVE SYSTEM			
TRAVEL SPEED (Low – High)	mph (km/h)	1.7/2.9 (2.8/4.7)	1.9/3.6 (3.1/5.8)
DRAWBAR PULL	lb. (kg)	31,966 (14 500)	51,588 (23 400)
MAXIMUM GRADE	% (°)	70 (35)	70 (35)
REFILL CAPACITIES			
FUEL TANK	gal. (L)	58 (220)	84.5 (320)
COOLING SYSTEM (Radiator Capacity)	gal. (L)	5.5 (21)	7.1 (27)
ENGINE OIL	gal. (L)	2.9 (11)	7.1 (27)
SWING DRIVE	gal. (L)	1.3 (5)	1.3 (5)
FINAL DRIVE (Each Side)	gal. (L)	0.8 (3.0)	0.8 (3.3)
HYDRAULIC SYSTEM	gal. (L)	43 (161)	60.8 (230)
HYDRAULIC TANK (Level)	gal. (L)	22 (85)	34.3 (130)

NOTE – Where applicable, dimensions are in accordance with Society of Automotive Engineers (SAE) and ISO standards. Specifications and design are subject to change without notice. Pictures of Doosan excavators may show other than standard equipment. All dimensions are shown in inches. Respective metric dimensions are enclosed by parentheses. Doosan Construction Equipment is manufactured with a Quality Management System that is in compliance with ISO 9001:2008.

All dimensions are given for Doosan excavators equipped with standard tracks.

Weight

	UNIT	DX140LCR-3	DX235LCR
CATEGORY			
BOOM	ft. in. (mm)	15' 1" (4600)	18' 8" (5700)
ARM	ft. in. (mm)	9' 10" (3000)	9' 6" (2900)
BUCKET	yd ³ (m ³)	0.5 (0.39)	1.20 (0.92)
DOZER BLADE LENGTH	ft. in. (mm)	N/A	N/A
DIMENSIONS (TRIPLE GROUSER)			
SHOE WIDTH - 2' 0" (600 mm) OPERATING WEIGHT GROUND PRESSURE	lb. (kg) psi (kgf/cm ²)	33,510 (15 200)* 5.5 (.39)	52,250 (23 700) 7.11 (.49)
SHOE WIDTH - 2' 4" (700 mm) OPERATING WEIGHT GROUND PRESSURE	lb. (kg) psi (kgf/cm ²)	33,951 (15 400) 4.8 (.34)	52,911 (24 000) 6.12 (.42)
SHOE WIDTH - 2' 8" (800 mm) OPERATING WEIGHT GROUND PRESSURE			53,572 (24 300)* 5.40 (.37)
SHOE WIDTH - 2' 11" (900 mm) OPERATING WEIGHT GROUND PRESSURE			54,234 (24 600) 4.84 (.33)

* = Standard Shoe Size

Hydraulic Cylinders

	UNIT	DX140LCR-3	DX235LCR
BOOM (2)			
BORE x ROD DIAMETER x STROKE (STD)	in. x in. x in. (mm x mm x mm)	4.3 x 3.0 x 43.4 (110 x 75 x 1103)	5.1 x 3.5 x 53.3 (130 x 90 x 1355)
ARM (1)			
BORE x ROD DIAMETER x STROKE (STD)	in. x in. x in. (mm x mm x mm)	4.5 x 3.1 x 43.6 (115 x 80 x 1108)	5.3 x 3.7 x 58.7 (135 x 95 x 1490)
BUCKET (1)			
BORE x ROD DIAMETER x STROKE (STD)	in. x in. x in. (mm x mm x mm)	3.9 x 2.8 x 35.4 (100 x 70 x 900)	4.7 x 3.1 x 41.7 (120 x 80 x 1060)

The piston rods and cylinder bodies are made of high-strength steel. A shock absorbing mechanism is fitted in all cylinders to ensure shock-free operation and extend piston life.

Digging Force (ISO)

DX140LCR-3

BUCKET (PCSA)	BUCKET SIZE (SAE)	0.51 yd ³ (0.39 m ³) STD	0.59 yd ³ (0.45 m ³)	0.67 yd ³ (0.51 m ³)
DIGGING FORCE	lbf.	24,471	24,471	24,471
	kgf	11 100	11 100	11 100
	kN	109	109	109
ARM		9' 10" (3000 mm) STD		
DIGGING FORCE	lbf.	13,228		
	kgf	6000		
	kN	59		

DX235LCR

BUCKET (PCSA)	BUCKET SIZE (SAE)	1.37 yd ³ (1.05 m ³)	1.53 yd ³ (1.17 m ³)	1.67 yd ³ (1.28 m ³)
DIGGING FORCE	lbf.	33,510	33,510	33,510
	kgf	15 200	15 200	15 200
	kN	149	149	149
ARM		9' 6" (2900 mm) STD		
DIGGING FORCE	lbf.	23,810		
	kgf	10 800		
	kN	106		

Specifications

Bucket

DX140LCR-3

					BOOM					
					15' 1" (4600 mm)					
					ARM		9' 10" (3000 mm)		9' 10" (3000 mm)	
					TRACK TYPE					
					FIXED		FIXED W/DOZER			
					SHOE SIZE					
					23.6" (600 mm)		23.6" (600mm)			
					MOUNT					
					Pin-On		Quick Coupler		Pin-On Quick Coupler	
BUCKET TYPE	MODEL	CAPACITY ¹ yd ³ (m ³)	WIDTH in. (mm)	WEIGHT lb. (kg)						
HEAVY DUTY ^{2,3}	HF40-018	0.27 (0.21)	20 (508)	796 (361)	A	A	A	A	A	A
	HF40-024	0.41 (0.31)	26 (660)	902 (409)	A	A	A	A	A	A
	HF40-030	0.55 (0.42)	32 (813)	1037 (470)	A	A	A	A	A	A
	HF40-036	0.68 (0.52)	38 (965)	1171 (531)	A	A	A	A	A	A
	HF40-042	0.82 (0.63)	44 (1118)	1253 (568)	A	B	A	A	A	A
DITCHING ⁴	BS8B48	0.64 (0.49)	48 (1219)	602 (273)	A	A	A	A	A	A
	BS8B60	0.80 (0.61)	60 (1524)	908 (412)	A	A	A	A	A	A
	BS8B72	0.98 (0.75)	72 (1829)	1047 (475)	A	A	A	A	A	A

DX235LCR

					BOOM			
					18' 8" (5700 mm)			
					ARM			
					9' 6" (2900 mm)			
					TRACK TYPE			
					FIXED			
					SHOE SIZE			
					31.5" (800 mm)			
					MOUNT			
					Pin-On		Quick Coupler	
BUCKET TYPE	MODEL	CAPACITY ¹ yd ³ (m ³)	WIDTH in. (mm)	WEIGHT lb. (kg)				
HEAVY DUTY ^{2,3}	HF49-024	0.59 (0.45)	26 (660)	1277 (579)	A	A		
	HF49-030	0.78 (0.60)	32 (813)	1466 (665)	A	A		
	HF49-036	0.99 (0.76)	38 (965)	1665 (755)	A	A		
	HF49-042	1.20 (0.92)	44 (1118)	1820 (826)	A	A		
	HF49-048	1.41 (1.08)	50 (1270)	1976 (896)	A	B		
DITCHING ⁴	B33B48	0.93 (0.71)	48 (1219)	903 (410)	A	A		
	B33B60	0.98 (0.75)	60 (1524)	1307 (593)	A	A		
	B33B72	1.2 (0.92)	72 (1829)	1499 (680)	A	A		

- 1 Capacity based on ISO 7451
- 2 Equipped with Side Cutters
- 3 Equipped with Bolt On Teeth
- 4 Equipped with Bolt On Cutting Edge

Maximum Suitable Material Density

- A 3,370 lb./yd³ (2,000 kg/m³)
- B 2,700 lb./yd³ (1,600 kg/m³)
- C 1,850 lb./yd³ (1,100 kg/m³)
- X Not Recommended

Dimensions

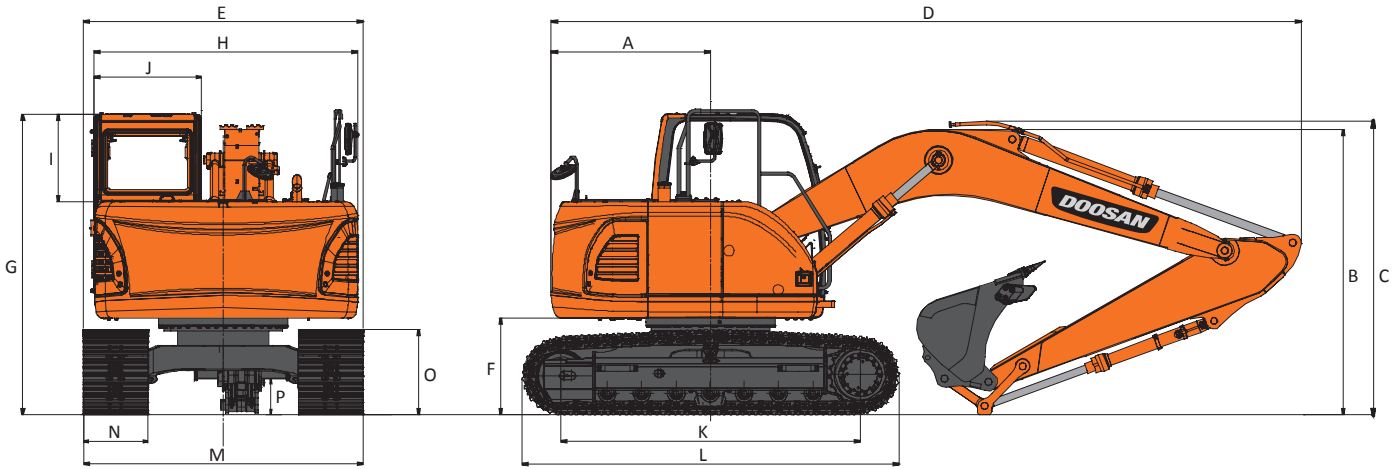

DX140LCR-3

BOOM		ft. in. (mm)	15' 1" (4600) STD
ARM		ft. in. (mm)	9' 10" (3000)
BUCKET TYPE (SAE)		yd ³ (m ³)	0.5 (0.39)
TRACK TYPE			STANDARD
TAIL SWING RADIUS	A	ft. in. (mm)	5' (1530)
SHIPPING HEIGHT (BOOM)	B	ft. in. (mm)	9' 11" (3030)
SHIPPING HEIGHT (HOSE)	C	ft. in. (mm)	10' 2" (3090)
SHIPPING LENGTH	D	ft. in. (mm)	24' (7320)
SHIPPING WIDTH	E	ft. in. (mm)	8' 6" (2590)
COUNTER WEIGHT CLEARANCE	F	ft. in. (mm)	2' 11" (895)
CABIN HEIGHT	G	ft. in. (mm)	9' 2" (2795)
UPPER STRUCTURE WIDTH	H	ft. in. (mm)	8' (2440)
CABIN HEIGHT ABOVE HOUSE	I	ft. in. (mm)	1' 6" (450)
CABIN WIDTH	J	ft. in. (mm)	3' 3" (980)
TUMBLER DISTANCE	K	ft. in. (mm)	9' 11" (3034)
OVERALL TRACK LENGTH	L	ft. in. (mm)	12' 4" (3755)
UNDERCARRIAGE WIDTH	M	ft. in. (mm)	8' 6" (2590)
TRACK SHOE WIDTH	N	in. (mm)	23.6" (600)
TRACK HEIGHT	O	ft. in. (mm)	2' 5" (728)
CAR BODY CLEARANCE	P	ft. in. (mm)	1' 4" (410)

DX235LCR

BOOM		ft. in. (mm)	18' 8" (5700) STD
ARM		ft. in. (mm)	9' 6" (2900)
BUCKET TYPE (SAE)		yd ³ (m ³)	1.20 (0.92)
TRACK TYPE			STANDARD
TAIL SWING RADIUS	A	ft. in. (mm)	5' 6" (1680)
SHIPPING HEIGHT (BOOM)	B	ft. in. (mm)	9' 5" (2870)
SHIPPING HEIGHT (HOSE)	C	ft. in. (mm)	9' 8" (2955)
SHIPPING LENGTH	D	ft. in. (mm)	29' 5" (8955)
SHIPPING WIDTH	E	ft. in. (mm)	10' 6" (3190)
COUNTER WEIGHT CLEARANCE	F	ft. in. (mm)	3' 4" (1025)
CABIN HEIGHT	G	ft. in. (mm)	10' 1" (3080)
UPPER STRUCTURE WIDTH	H	ft. in. (mm)	9' 5" (2870)
CABIN HEIGHT ABOVE HOUSE	I	ft. in. (mm)	2' 6" (760)
CABIN WIDTH	J	ft. in. (mm)	3' 3" (980)
TUMBLER DISTANCE	K	in. (mm)	12' (3650)
OVERALL TRACK LENGTH	L	ft. in. (mm)	14' 7" (4445)
UNDERCARRIAGE WIDTH	M	ft. in. (mm)	10' 6" (3190)
TRACK SHOE WIDTH	N	in. (mm)	31.5" (800)
TRACK HEIGHT	O	ft. in. (mm)	3' 1" (947)
CAR BODY CLEARANCE	P	ft. in. (mm)	1' 7" (480)

Specifications

Working Range

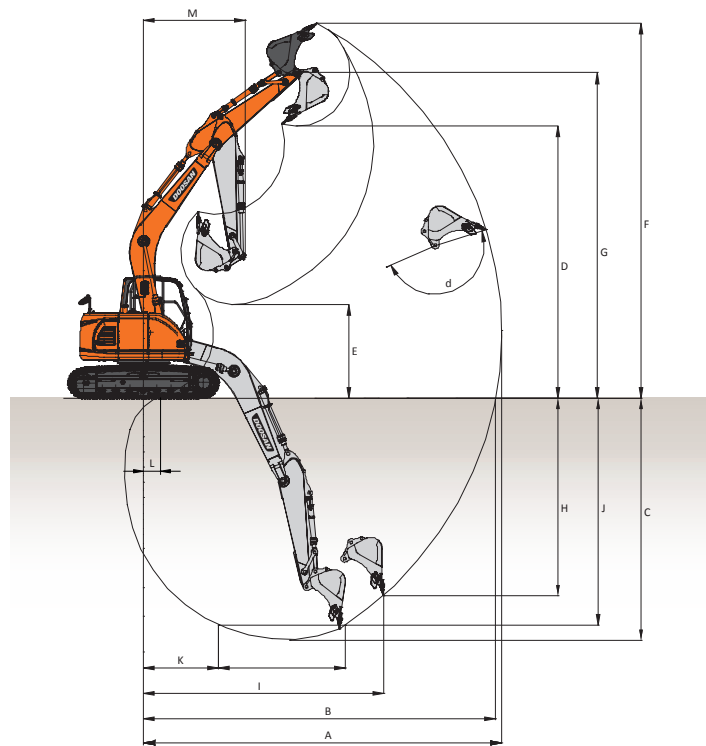

DX140LCR-3

BOOM TYPE	ft. in. (mm)	15' 1" (4600)
ARM TYPE	ft. in. (mm)	9' 10" STD (3000)
BUCKET TYPE (SAE) PCSA	yd ³ (m ³)	0.5 (0.39)
TRACK TYPE		STANDARD
MAX. DIGGING REACH	A ft. in. (mm)	28' 5" (8665)
MAX. DIGGING REACH (GROUND)	B ft. in. (mm)	28' (8530)
MAX. DIGGING DEPTH	C ft. in. (mm)	19' 8" (5985)
MAX. LOADING HEIGHT	D ft. in. (mm)	23' 3" (7080)
MIN. LOADING HEIGHT	E ft. in. (mm)	6' 11" (2120)
MAX. DIGGING HEIGHT	F ft. in. (mm)	31' 1" (9470)
MAX. BUCKET PIN HEIGHT	G ft. in. (mm)	27' 3" (8300)
MAX. VERTICAL WALL DEPTH	H ft. in. (mm)	15' 4" (4680)
MAX. RADIUS VERTICAL	I ft. in. (mm)	19' 7" (5970)
MAX. DEPTH TO 8' LINE	J ft. in. (mm)	18' 11" (5765)
MIN. RADIUS 8' LINE	K ft. in. (mm)	6' 8" (2040)
MIN. DIGGING REACH	L ft. in. (mm)	-5 (-130)
MIN. SWING RADIUS	M ft. in. (mm)	7' 7" (2320)
BUCKET ANGLE (DEG)	d degrees	174°

DX235LCR

BOOM TYPE	ft. in. (mm)	18' 8" (5700) STD
ARM TYPE	ft. in. (mm)	9' 6" (2900)
BUCKET TYPE (SAE) PCSA	yd ³ (m ³)	1.20 (0.92)
TRACK TYPE		STANDARD
MAX. DIGGING REACH	A ft. in. (mm)	32' 3" (9820)
MAX. DIGGING REACH (GROUND)	B ft. in. (mm)	31' 7" (9630)
MAX. DIGGING DEPTH	C ft. in. (mm)	21' 11" (6670)
MAX. LOADING HEIGHT	D ft. in. (mm)	26' 1" (7955)
MIN. LOADING HEIGHT	E ft. in. (mm)	10' 4" (3155)
MAX. DIGGING HEIGHT	F ft. in. (mm)	35' 5" (10795)
MAX. BUCKET PIN HEIGHT	G ft. in. (mm)	30' 10" (9405)
MAX. VERTICAL WALL DEPTH	H ft. in. (mm)	17' 7" (5350)
MAX. RADIUS VERTICAL	I ft. in. (mm)	21' 6" (6550)
MAX. DEPTH TO 8' LINE	J ft. in. (mm)	21' 2" (6440)
MIN. RADIUS 8' LINE	K ft. in. (mm)	8' 5" (2570)
MIN. DIGGING REACH	L ft. in. (mm)	1' 4" (395)
MIN. SWING RADIUS	M ft. in. (mm)	7' 7" (2310)
BUCKET ANGLE (DEG)	d degrees	177°

- Standard Equipment
- Optional Equipment
- N/A

Standard/Optional Equipment

	DX140LCR-3	DX235LCR
ENGINE		
Emissions (EPA)	IT4	T3
Cooled Exhaust Gas Recirculation (CEGR)	•	•
High Pressure Common Rail (HPCR)	•	•
Fuel Filter with Water Separator	•	•
Coolant Recovery tank	•	•
Short Side, Inlet Transition Air Filter	•	•
Pre Cleaner	•	•
Electronic Engine Control	•	•
Auto-Idle	•	•
Overheat & Low Oil Pressure Engine Protection	•	•
Electronic Controlled Variable Speed Radiator Cooling Fan	•	•
HYDRAULIC		
Electronic Power Optimizing System (EPOS)	•	•
Swash Plate, Axial Piston Main Pump	•	•
Cross Sensing Pump Control	•	•
Pilot Operated Control Valves	•	•
Gear Pilot Pump	•	•
Electronic Controlled Cooling Fan	•	•
Axial Piston Swing Motor	•	•
Spring Applied Hydraulic Release Brake	•	•
Axial Piston Travel Motor (High/Low, Auto)	•	•
Auxiliary Hydraulics, One-Way	•	•
Auxiliary Hydraulics, Two-Way	•	■
Adjustable Auxiliary Flow & Pressure, 10 Presets	•	•
Boom Lock Valve	■	■
CABIN		
Steel, All-Weather & Sound Suppressed	•	•
ROPS (ISO 12117-2:2008)	•	•
Viscous Mount	•	•
Front Window with Wiper/Washer	•	•
Tinted Safety Glass	•	•
Skylight	•	•
Visor, Front Window and Skylight	•	•
Pull Up Type Top Front Window	•	•
Removable Lower Front Window with Storage Behind Seat	•	•
Adjustable Sliding Side Door Windows	•	•
Defrost, Front Window	•	•
Lockable Doors	•	•
Seat		
- Heated		
- Air Suspension		
- 2" (51 mm) Seat Belt	•	•
- Adjustable Height & Recline		
- Adjustable Arm Rests		
3" (76 mm) Seat Belt	■	■
Control Stands		
- Height adjustable	•	•
- Mounted to Seat Base		
Storage for Operator's Manuals	•	•
Mirrors	•	•
Fully Automatic HVAC w/ ambient temperature sensor	•	•
7" Multi-Function LCD	•	•
Cigarette Lighter	•	•
AM/FM Stereo with CD Player & MP3 port	•	•
Speakers (2)	•	•
Antenna, Roof Mounted	•	•
Emergency Breakout Tool	•	•
Hot/Cold Beverage Compartment	•	•
Power Socket, 12V	•	•
Beverage Holder	•	•
Interior Light	•	•
Coat Hanger	•	•
Rain Shield	■	■
Guard, FOGS	■	■
Guard, front window guard	■	■
Vandalism Window Covers	■	■
ELECTRICAL		
Alternator – 24V, 70 Amp	•	•
2 x 12V Batteries, 100 AH Reserve Capacity	•	•
Blade Type Fuse Panel	•	•
Main Circuit Breaker	•	•

	DX140LCR-3	DX235LCR
ELECTRICAL (CONT.)		
Light, Work (Halogen): Machine (2), Boom (2)	•	•
Light, Work (Halogen): Cabin (2)	■	■
Light, Work (Halogen): Cabin (4 Front, 2 Rear)	■	■
Rotating Beacon	■	■
Hour Meter	•	•
Engine Restart Prevention System	•	•
Rear View Camera	•	•
Laptop Service Port	•	•
Self-Diagnostics System	•	•
Telematics	•	•
DISPLAY MONITOR & WARNINGS		
Buzzer		
- Engine Oil Pressure	•	•
- Coolant Temperature		
Gauges		
- Engine Coolant Temperature		
- Fuel Level	•	•
- Hydraulic Oil Temperature		
- Engine RPM		
- Battery Voltage		
- Hydraulic Pump Pressure		
- ECO		
- Digital Clock		
Warning & Indicator Lights		
- Engine Coolant Temperature		
- Fuel Level		
- Hydraulic Oil Temperature		
- ECO		
- Digital Clock		
- Warning & Indicator Lights		
- Hydraulic Oil Temperature – High		
- Fuel Level – Low		
- Air Filter – Clogged		
- Hydraulic Pilot Filter – Clogged		
- Hydraulic Return Filter – Clogged		
- Check Engine		
- Engine Oil Pressure – Low		
- Hydraulic Charge Pressure – Low		
- Coolant Temperature – High		
- Work Lights On		
- Water in Fuel		
Swing Alarm	■	■
Travel Alarm	•	•
UNDERCARRIAGE		
Track Guards and Chains with Adjusters	•	•
Track Rollers, Upper (1 Each Side)	•	•
Track Rollers, Lower (7 Each Side)	•	•
In-Shoe Motor Protection	•	•
Shoes, Triple Grouser – 600 mm	•	■
Shoes, Triple Grouser – 700 mm	■	■
Shoes, Triple Grouser – 800 mm	–	•
Shoes, Triple Grouser – 900 mm	–	■
CONTROLS		
Joystick Controls	•	•
Pattern Control Change Valve (SAE, ISO)	•	•
Joystick Attachment Control Switches/Buttons		
- One-way	•	•
- Two-way		
- Power Boost		
Control Stands		
- Height Adjustable	•	•
- Sliding (Fore/Aft)"		
Engine Speed Control Dial	•	•
Travel Pedals with Hand Levers	•	•
Straight Travel Pedal	■	–
Switches, Console mounted		
- Starter (Key)		
- Travel Speed Selector		
- Work Light	•	•
- DPF Regeneration		
- Auxiliary Mode Switch		
- Emergency Stop Switch		
Power Mode (P+, P, S, E)	•	•
Work Mode (Digging, Lifting, Breaker, Shear)	•	•
Wiper Control Panel	•	•
Audio Control Panel	•	•
OTHER		
Centralized Lubrication		
- Boom	•	•
- Swing Bearing		
Dozer Blade	■	–
Handrails	•	•
Skid-Resistant Steps	•	•
Manuals		
- Operations & Maintenance	•	•
- Parts,		
- AEM Safety Manual		
Telematics, 1 Year Subscription	•	•
Vandalism Protection		
- Lockable panels	•	•
- Lockable fluid fill points		

Specifications

Lifting Capacity

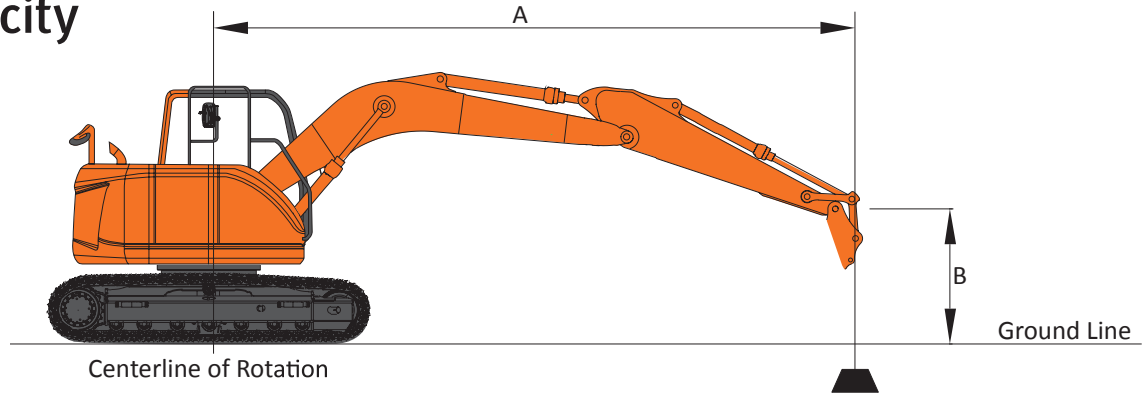

DX140LCR-3

Track Width: 8' 6" (2600 mm) STD TRACK
 Boom: 15' 1" (4600 mm)
 Arm: 9' 10" (3000 mm)

Bucket: None
 Track Shoe Width: 24" (600 mm)
 Counter Weight: 7,716 lb (3500 kg)

Load Radius Over Front
 Load Radius Over Side
 Unit: 1,000 lb (1000 kg)

Feet

B ft \ A ft	10		15		20		MAX F	MAX S	MAX REACH
									A ft
25							5.46*	5.46*	13.62
20			7.15*	7.15*			4.53*	4.53*	19.17
15			7.80*	7.80*	6.8*	5.25	4.27*	4.27*	22.25
10	12.15*	12.15*	10.31*	7.97	8.02	5.08	4.3*	3.77	23.91
5	19.95*	13.55	12.14	7.39	7.75	4.83	4.58*	3.54	24.44
0 (GROUND)	19.28*	12.57	11.61	6.94	7.51	4.62	5.16*	3.57	23.91
-5	23.17*	12.33	11.37	6.73	7.4	4.52	6.31*	3.92	22.24
-10	20.58*	12.48	11.41	6.76			7.97	4.87	19.14
-15	13.84*	13.03					9.68*	8.18	13.61

Metric

B m \ A m	1.5		3		4.5		6		MAX F	MAX S	MAX REACH (m)
											A m
8									2.42*	2.42*	4.34
7.5									2.42*	2.42*	4.34
6					3.27*	3.27*			2.04*	2.04*	5.91
4.5					3.56*	3.56*	3.2*	2.44	1.94*	1.94*	6.82
3			5.81*	5.81*	4.75*	3.7	3.73	2.36	1.95*	1.70	7.3
1.5			9.27*	6.29	5.64	3.43	3.6	2.24	2.08*	1.60	7.45
0 (GROUND)			8.35*	5.85	5.4	3.22	3.49	2.14	2.34*	1.62	7.29
-1.5	5.21*	5.21*	10.13*	5.74	5.29	3.12	3.43	2.09	2.85*	1.77	6.79
-3	8.20*	8.20*	9.53*	5.81	5.31	3.13			3.58	2.19	5.87

1. Load point is the end of the arm.
2. Capacities marked with an asterisk (*) are limited by hydraulic capacities.
3. Lift capacities shown do not exceed 75% of minimum tipping loads or 87% of hydraulic capacities.
4. The least stable position is over the side.
5. Lift capacities are in compliance with ISO 10567.

Lifting Capacity

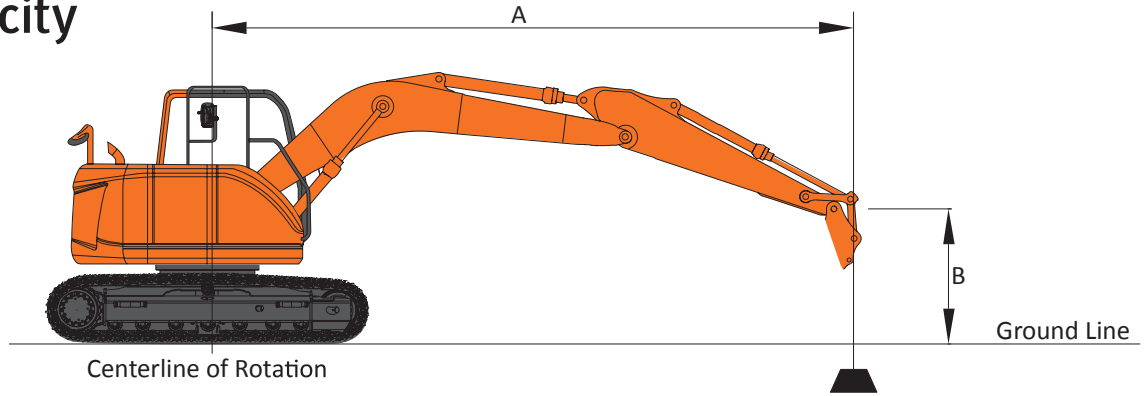

DX235LCR

Track Width: 8' 6" (2590 mm) STD TRACK	Bucket: SAE 1.20 yd ³ (0.92 m ³)	Blade: None	Load Radius Over Front
Boom: 18' 8" (5700 mm)	Track Shoe Width: 32" (800 mm)		Load Radius Over Side
Arm: 9' 6" (2900 mm)	Counter Weight: 4,850 lb (2200 kg)		Unit: 1,000 lb (1000 kg)

Feet

B ft \ A ft	10		15		20		25		MAX F	MAX S	MAX REACH
											A ft
25			*11.95	*11.95					*8.50	*8.50	Max. at(ft) 19.29
20			*12.73	*12.73	*12.13	10.12			*8.14	7.66	Max. at(ft) 23.20
15	*19.97	*19.97	*15.63	*15.63	*13.54	9.68	*9.58	6.47	*8.31	6.21	Max. at(ft) 25.53
10	*31.98	27.84	*19.96	14.38	*15.50	9.06	10.77	6.19	*8.91	5.47	Max. at(ft) 26.74
5	*17.46	*17.46	*23.90	13.11	14.95	8.45	10.44	5.89	9.23	5.17	Max. at(ft) 26.98
0 (GROUND)	*21.52	*21.52	23.29	12.41	14.46	8.02	10.19	5.66	9.45	5.24	Max. at(ft) 26.26
-5	*29.95	24.35	23.04	12.20	14.26	7.84			10.43	5.77	Max. at(ft) 24.51
-10	*32.56	24.83	*23.04	12.35	14.37	7.93			12.89	7.16	Max. at(ft) 21.47
-15	*24.18	*24.18	*17.34	12.91					*15.58	11.26	Max. at(ft) 16.39

Metric

B m \ A m	2		3		4		5		6		7		8		MAX F	MAX S	MAX REACH (m)
																	A m
8							*4.77	*4.77							*3.95	*3.95	Max. at(m) 5.48
7							*5.46	*5.46	*4.66	*4.66					*3.75	*3.75	Max. at(m) 6.43
6							*5.76	*5.76	*5.61	4.72	*4.06	3.54			*3.69	3.42	Max. at(m) 7.13
5					*7.02	*7.02	*6.40	6.28	*5.97	4.59	*5.38	3.48			*3.73	2.96	Max. at(m) 7.62
4	*17.47	*17.47	*11.08	*11.08	*8.62	8.62	*7.31	5.98	*6.51	4.41	5.76	3.37			*3.85	2.66	Max. at(m) 7.96
3			*15.02	12.91	*10.49	8.05	*8.37	5.64	*7.15	4.21	5.62	3.25	4.49	2.57	*4.05	2.47	Max. at(m) 8.16
2			*7.98	*7.98	*12.16	7.49	*9.37	5.32	7.05	4.01	5.49	3.13	4.41	2.49	4.21	2.37	Max. at(m) 8.23
1			*7.79	*7.79	*13.23	7.12	9.25	5.07	6.86	3.85	5.37	3.02	4.34	2.42	4.19	2.34	Max. at(m) 8.18
0 (GROUND)			*9.50	*9.50	13.49	6.93	9.06	4.91	6.73	3.72	5.28	2.94	4.29	2.38	4.29	2.38	Max. at(m) 8.00
-1	*8.70	*8.70	*11.88	11.35	13.41	6.86	8.96	4.83	6.65	3.66	5.23	2.89			4.53	2.51	Max. at(m) 7.69
-2	*11.36	*11.36	*14.82	11.44	*12.92	6.87	8.95	4.81	6.63	3.64	5.22	2.89			4.98	2.76	Max. at(m) 7.23
-3	*14.30	*14.30	*15.04	11.60	*11.89	6.96	9.00	4.86	6.68	3.68					5.79	3.22	Max. at(m) 6.58
-4	*16.51	*16.51	*12.79	11.85	*10.27	7.12	*8.29	4.98							*7.07	4.12	Max. at(m) 5.68
-5			*9.50	*9.50	*7.65	7.40									*6.96	6.42	Max. at(m) 4.37

1. Load point is the end of the arm.
2. Capacities marked with an asterisk (*) are limited by hydraulic capacities.
3. Lift capacities shown do not exceed 75% of minimum tipping loads or 87% of hydraulic capacities.
4. The least stable position is over the side.
5. Lift capacities are in compliance with ISO 10567.



DOOSAN

**A NAME YOU CAN'T FORGET.
PRODUCTS YOU CAN'T IGNORE.**

If you want to do more, there are two simple syllables you need to remember. Doosan. Doosan delivers performance, productivity, durability, comfort and easy maintenance in all of its machines. When you look into our products and our committed dealer and support networks, you'll know that we're up for your biggest, toughest jobs. And once you experience for yourself what these machines can do, you'll never forget it.



DOOSAN

1.877.613.7970
DoosanEquipment.com/Hex

Doosan and the Doosan logo are registered trademarks of Doosan Corp. in the United States and various other countries around the world. ©2014 Doosan Infracore Construction Equipment America. All rights reserved.

D-1026 (06/14)



Printed on 10%
recycled paper

Printed in U.S.A.

Doosan Delivers

Kn-2M-614-30830-F