

ARTICULATED DUMP TRUCKS PRODUCT INFORMATION

machinery for challenging conditions



WIN-WIN PARTNERSHIP BETWEEN DOOSAN INFRACORE AND MOXY TRUCKS

BUILT BY MOXY'S TECHNOLOGY AND PRESENTED BY DOOSAN INFRACORE.
GROWING, ENHANCING TECHNOLOGY, INCREASING THE PRODUCT OFFERING AND PROVIDING A
BIGGER OPPORTUNITY FOR CUSTOMERS.



THE NEXT GENERATION OF ARTICULATED DUMP TRUCKS OFFERS RELIABLE MACHINERY FOR CHALLENGING CONDITIONS

DOOSAN MOXY strives to be a pioneer in the field of product development and performance.

With the new generation of DOOSAN MOXY articulated dump trucks, the product features have been refined and innovated to meet the tough demands of the future. Our philosophy is to stay one step ahead of the competition and always deliver a full-range of articulated dump trucks to the market.

DOOSAN MOXY PLUS 1 CONCEPT

Our goal has been to develop a new line of advanced reliable and cost effective articulated dump trucks, loaded with significant competitive advantages.

With the new, modern product design and sophisticated technical features, DOOSAN MOXY is proud to introduce the unique MOXY Plus 1 concept with the following benefits:

Plus 1 **Productivity**

Plus 1 **Power**

Plus 1 **Traction**

Plus 1 **Stability**

Plus 1 **Reliability**

Plus 1 **Comfort**





DOOSAN MOXY Plus 1 Concept

Plus1 Power



DOOSAN MOXY uses proven, reliable and powerful diesel engines with excellent torque which achieves low fuel consumption and fulfills Tier 3 US/EPA regulation guidelines.

DOOSAN MOXY utilizes reliable transmissions that feature smooth gear shifting abilities. These features result in the maximum net power transmission to the wheels, resulting in maximum fuel efficiency.

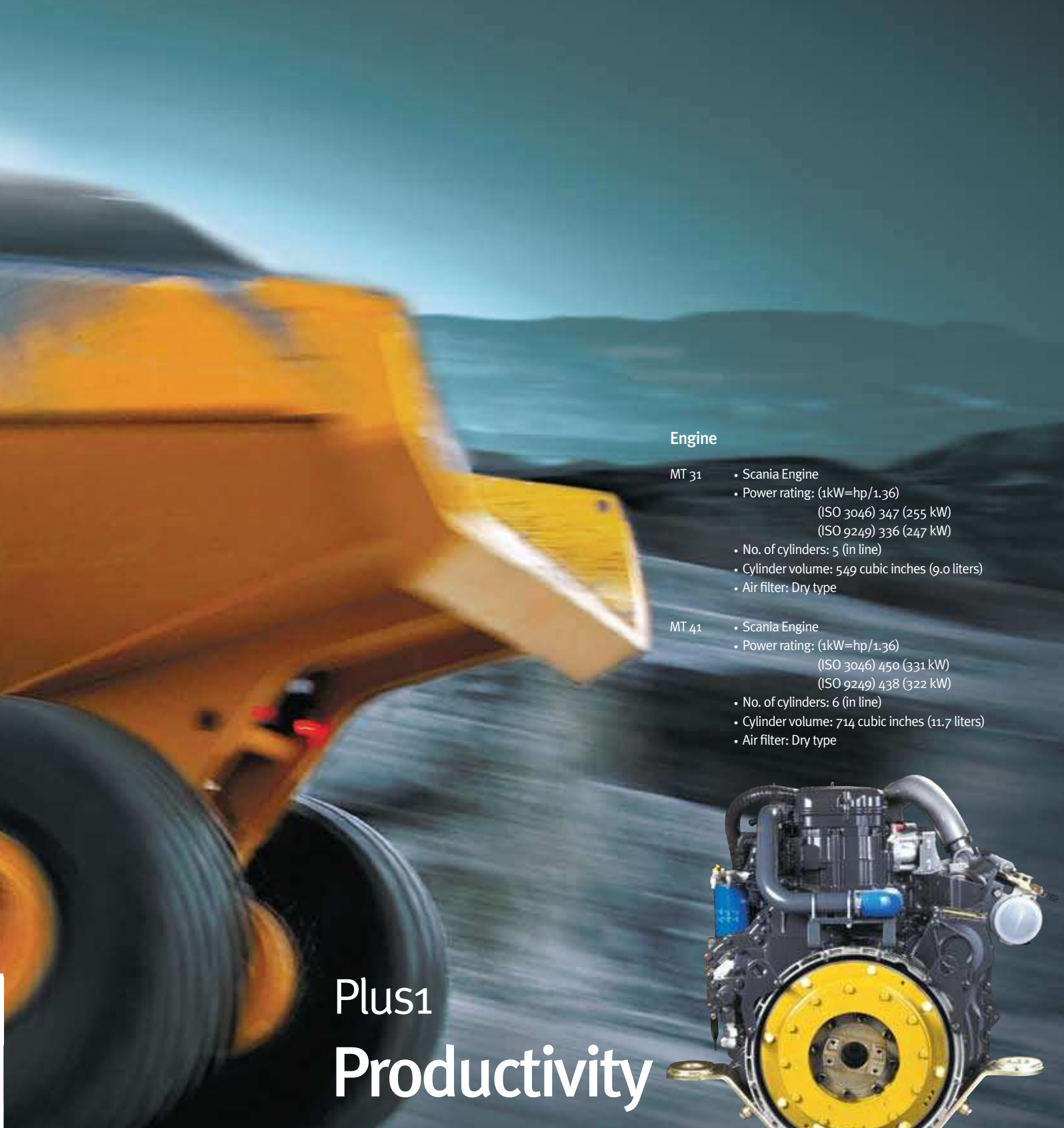

Plus1 Productivity

Engine

- MT 31
 - Scania Engine
 - Power rating: (1kW=hp/1.36)
 - (ISO 3046) 347 (255 kW)
 - (ISO 9249) 336 (247 kW)
 - No. of cylinders: 5 (in line)
 - Cylinder volume: 549 cubic inches (9.0 liters)
 - Air filter: Dry type
- MT 41
 - Scania Engine
 - Power rating: (1kW=hp/1.36)
 - (ISO 3046) 450 (331 kW)
 - (ISO 9249) 438 (322 kW)
 - No. of cylinders: 6 (in line)
 - Cylinder volume: 714 cubic inches (11.7 liters)
 - Air filter: Dry type



The DOOSAN MOXY Plus 1 concept offers a larger load capacity in all weight class categories. Additional load capacity, combined with superior power and traction allow for improved productivity. The unique advantages of DOOSAN MOXY'S permanent six-wheel drive, free-swinging rear tandem articulation hinge

system, independent front wheel suspension system and sloping rear frame provide excellent driving stability with equal weight distribution and wheel power. The DOOSAN MOXY articulated dump truck is designed to work under rough conditions and can also travel at speeds up to 31 mph.

DOOSAN MOXY Plus 1 Concept

Plus1 Stability

DOOSAN MOXY'S free-swinging rear tandem bogie and the special articulation system offer excellent performance and the best possible ground contact in soft and difficult terrain. The sloping rear frame, in combination with the track width, ensures a lower center of gravity

and class-leading sideways stability, which removes the need for wide, low profile tires. One of the main highlights of the DOOSAN MOXY concept is the location of the turning ring in relation to the swing point which always ensures equal weight distribution to the front wheels.

Equal distribution to the front wheels makes it possible to use the differentials while maintaining maneuverability. DOOSAN MOXY'S unique independent front wheel suspension allows for maximum ground contact and shock absorption.



Plus1 Traction



The unique DOOSAN MOXY concept offers permanent six-wheel drive which ensures stability and equal distribution to accommodate all job applications.

DOOSAN MOXY'S superior driveline ensures maximum traction performance and durability.

DOOSAN MOXY Plus 1 Concept

Plus1 Reliability



DOOSAN MOXY has one of the most reliable dump trucks in the industry because of its strong and reliable system solutions. The automatic central lubrication system is standard on all DOOSAN MOXY models. With

over thirty years dedicated to product development, the new generation of DOOSAN MOXY trucks provides innovative drive train and fatigue-proof structure.

Plus1 Comfort

The cabin is equipped with air-conditioning and an operator seat with air suspension to provide excellent operator comfort. Precise steering, good visibility and low noise levels provide a comfortable cabin environment. The “tip-tronic” gearshift feature enables the operator to run the truck in both automatic and manual gears to ensure the smoothest possible gear-shifts and

momentum while operating the truck. The sloping hood provides an excellent view from the operator’s position combined with good rear visibility. DOOSAN MOXY cares about the environment and aims to set the best possible standards in the manufacturing of our products. DOOSAN MOXY utilizes industry leading engines that achieve low fuel consumption and fulfill the

latest Tier 3 US/EPA regulations in addition to all noise regulations. DOOSAN MOXY provides exceptional operator comfort with low cabin vibration levels. Minimal fuel consumption is achieved while lock-up clutch is engaged in mechanical mode.





Line Up

MT51

Highline Equipment

MT26, MT31, MT36, MT41 (MT51)

Standard

- Tilttable cabin with hydraulic pump
- Cabin top hat
- Instructor seat with safety belt
- Radio / CB-player
- Front wheel mudflaps
- Front mudguards extension
- Mudflaps in front of bogie
- Working light / Extra high beam
- Automatic lubrication system
- ROPS / FOPS safety cabin
- Cabin heater and defroster
- Air conditioner (refrigerant R134a)
- Adjustable air - suspended operator seat with armrest and headrest
- Safety belt on operator seat
- Tilt and height adjustable steering column
- Comprehensive instrumentation
- Speedometer
- Cigarette lighter and ashtray
- Retractable roller sunblind
- Tinted safety glass
- Sliding window left-hand side
- Windshield wiper and washer
- Four exterior mirrors
- Protective grille for rear window
- Emergency steering
- Air cleaner service indicator
- Protection under engine and transmission
- Towing hook-front/rear
- Exhaust brake
- Retarder brake
- Parking brake alert system
- Directional and warning lights
- Brake lights
- Head lights (H3/H7)
- Parking lights
- Diode rear light
- Back-up light and alarm
- Cabin interior light
- Instrument and switch lighting
- Front light protection
- Battery main switch



MT41 MT36

MT31 MT26

Options

- Heated operator seat
- Sliding window, front, right-hand side
- Sliding window, rear, right-hand side
- Sliding window, door, right-hand side
- Radio / Cassette-player
- Heated mirrors
- Rotating beacon
- Extra back-up light (work light on mirror arms)
- Rear view system
- First aid kit
- Fire extinguisher
- Warning triangle
- Body lining (plates)
- Protection in front of body (spillguard)
- Top tailgate kit
- Wheel chocks (set of 2)
- Exhaust heated body kit
- Electrical engine coolant heater
- Tool kit (spanners, socket etc.)
- Low profile tires

Unique Concept of DOOSAN MOXY ADT

Best Structure for All-Condition Terrain

DOOSAN MOXY articulated dump trucks have permanent 6-wheel drive for equal power distribution while the free-swinging rear tandem bogie and the special articulation system offer excellent driving performance. The articulation hinge is positioned behind the turning ring to ensure equal

weight distribution. The sloping body design further enhances Doosan Moxy stability and ensures fast and easy tipping for increased productivity in even the most demanding conditions. Many DOOSAN MOXY machines have worked more than 25,000 hours without any major overhaul of the

engine. Fully automatic transmission control unit and smooth gear-shifting abilities enable the operator to concentrate on working conditions with maximum comfort.

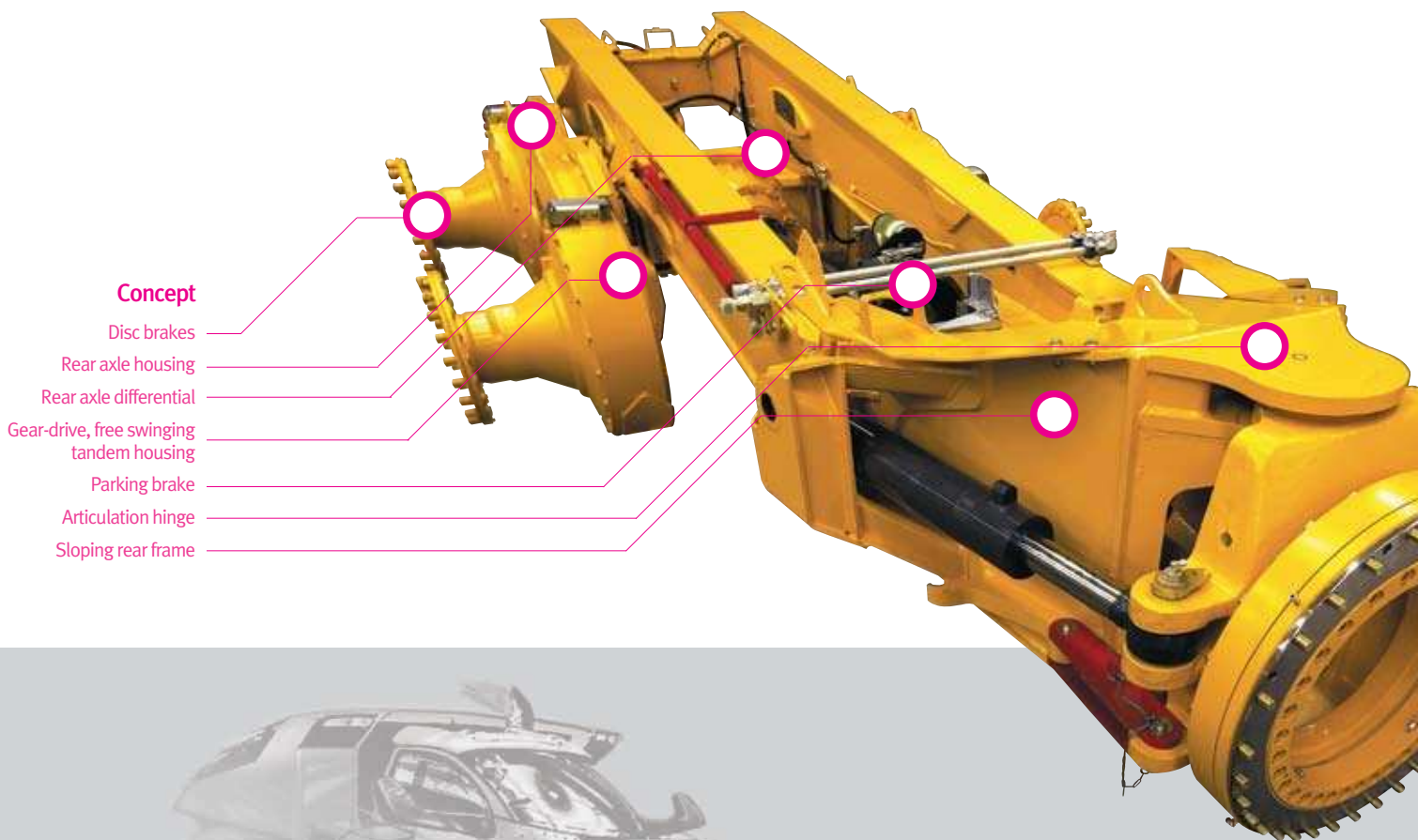

Top 10 Advantages of DOOSAN MOXY Articulated Dump Trucks

- Low operating cost
- Excellent performance in difficult terrain
- Independent front suspension ensures maximum ground contact and stability
- The sloping rear frame ensures low center of gravity, good stability and excellent weight distribution to the front axle
- Improved driver comfort and easy operation
- Tier 3 of USA/California regulations (ISO 8178) for emissions
- Free-swinging rear tandem bogie ensures the best possible ground contact
- Articulation hinge system ensures equal weight distribution to the front axle in all situations
- Permanent 6-wheel drive, a significant advantage in rugged terrain
- Easy maintenance

	Moxy MT26-III	Moxy MT31-III	Moxy MT36	Moxy MT41
Engine	Scania DC9	Scania DC9	Scania DC12	Scania DV12
Configuration	5 in Line / 9.0 liter	5 in Line / 9.0 liter	6 in Line / 11.7 liter	6 in Line / 11.7 liter
Gross Power	228 kw @2200 Rpm	255 kw @2200 Rpm	294 kw @2200 Rpm	331 kw @2200 Rpm
Net Power	224 kw @2200 Rpm	247 kw @2200 Rpm	285 kw @ 2200 Rpm	322 kw @2200 Rpm
Gross Torque	1345 Nm @1500 Rpm	1455 Nm @ 1500 Rpm	1854 Nm @1500 Rpm	1854 NM @1200 Rpm
Load Index	25.33 kw / liter	28.33 kw//liter	25-13 kw/liter	28.29 kw/liter
Capacity	SAE 2:1	SAE 2:1	SAE2:1	SAE 2:1
Body Volume	14.7m ³	17.6m ³	20.1m ³	22.7m ³
Density Index	1.64 t/m ³	1.62t/m ³	1.64t/m ³	1.64t/m ³
Gross Weight	44.95 tons	49.8 tons	61.4 tons	66.4 tons
Net Weight	20.4 tons	21.3 tons	28.8 tons	29.2 tons
Payload Kg	24100	28,500		
Power to Weight	Net Power vs Tons	Net Power vs Tons	Net Power vs Tons	Net Power vs Tons
Empty	10.98 kw/t	11.60 kw/t	9.90 kw/t	10.82 kw/t
Loaded	5.03 kw/t	4.95 kw/t	4.63 kw/t	4.76 kw/t
Transmission	ZF 6WG260 RPC Countershaft	ZF 6WG260 RPC Countershaft	ZF 6WG310 RPC Countershaft	ZF 6WG310 RPC Countershaft
Speeds	6F - 3R	6F - 3R	6F - 3R	6F - 3R
Travel Speed	51.0/33.0 km/h	51/33 km/h	51.0 / 31.0 km/h	53.0/34.0 km/h
Brakes				
Front	Wet Multiple Disc	Wet Multiple Disc	Wet Multiple Disc	Wet Multiple Disc
Rear	Wet Multiple Disc	Wet Multiple Disc	Wet Multiple Disc	Wet Multiple Disc
Retarder	Exhaust Brake & T/M Retarder	Engine Exh & T/M Ret Brake	Engine Brake & T/M Retarder	Engine Brake & T/M Retarder
Body	Hardo x 400	Hardox 400	Hardox 400	Hardox 400
Dimensions				
Tot Lenght	9816 mm	9857 mm	10450 mm	10445 mm
Width	2750 mm	2990 mm	3275 mm	3460 mm
Load over Height	2864 mm	2946 mm	3440 mm	3185 mm
Turning Radius	8.9 m	8.7 m	8.85 m	8.8 m

The DOOSAN MOXY Concept -

Ultimate Efficiency

Lower power curve when empty plus reduced weight achieved through state of the art design and lightweight, high grade, wear resistant steel.

Ultimate Traction & Stability

Sloping Frame, well positioned turning ring and excellent weight distribution remove the need for wide, low profile tires, significantly reducing running costs. New skip design further improves stability while tipping.

Ultimate Power/Weight Ratio

Class-leading power to weight ratio of 6.48hp per ton

Ultimate Comfort

Fully independent nitrogen suspension and new, highly specified cabin offer unparalleled levels of comfort.

Ultimate Service Access

Remote mounted service points mean general servicing can be completed at ground level. Excellent access is offered by the side tilting cabin. Hood design capable of opening to 83° for the improved access.

Ultimate Safety

Superior visibility because of new front wagon design.

Unique Concept of DOOSAN MOXY ADT

Forward mounted turning ring

One of the main points in the Doosan Moxy concept is the location of the turning ring in relation to the swing point. The turning ring is located in front of the swing point which always ensures equal weight distribution to the front wheels in all situations, also during maximum turning. Equal weight distribution to the front wheels makes it possible to use the differential with only 45% locking value. This provides drive to both wheels in all situations without completely locking up the wheels. Our competitors have located the turning

ring behind the swing point giving different weight distribution to the front wheels. Due to differentials on the front wheels, our competitors use 100% differential lock causing steering difficulties. A differential lock of 100% creates more force on the driveline in all turns resulting in a higher amount of wear on the tires.

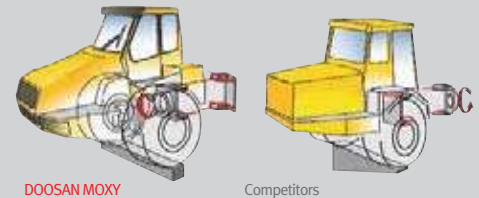

Weight Distribution Articulation System

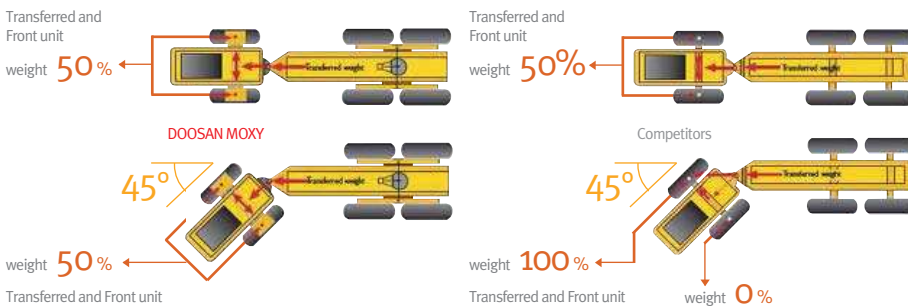

Unique Frame Sloping for Weight Distribution

Moxy's philosophy on frame design is generally the same as manufacturers of rigid dump trucks. The frame is inclined (sloped) downward from the hinge points to obtain equal weight distribution on all axles while fully-loaded. As a result, lower center of gravity is obtained giving better stability.



Front Wheel Suspension

Moxy's unique independent front suspension allows for free movement on one side movement contact and shock absorption. Our competitors use rigid axles which cause movement on the opposite side of the axle which results in driver discomfort.



Free - swinging Tandem Housing

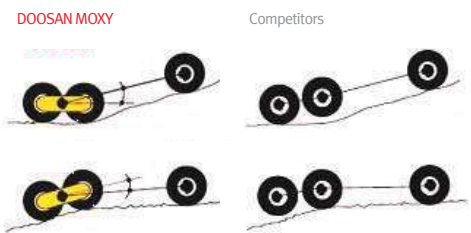

Excellent Service Accessibility

- The hood has a wide opening to provide accessibility to the engine for easy maintenance
- The tilting cabin allows the same clear access to the transmission and hydraulic components
- All electrical and AC connections are at the rear of the cabin. This allows tilting of the cabin without disconnecting.



Improvements of III Series



New weight - saving bogie design
oil immersed brakes front & rear

Best Ground Contact in All Condition Terrain



Operating in Tough Conditions

Operating on Extreme Terrain

Dumping

Hauling

Excellent Tire Wear Prevention

DOOSAN MOXY driveline only requires 1 diff lock/

limited slip diff mounted on the rear tandem

- Competitors drive line requires 2 units on the rear axles
- Competitors' rear diff's get a lot of wear because of the nature of the operation between the middle axle and rear axle because a inter axle lock unit between the 2 rear axle diff's

DOOSAN MOXY Drive Line

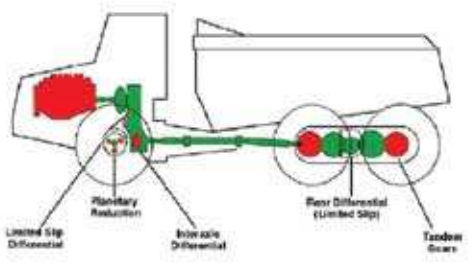

Competitors Drive Line

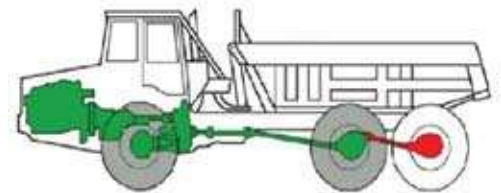

Green: Normal Drive
Red: 6-Wheel Drive With Wind-Up

Wet Disk Brake in Whole Line Up

- More efficient braking under load, which means less brake fade because of the oil cooling plus more brake force
- Less servicing intervals, brake discs last longer - In very adverse conditions like deep mud and water, the dry disc brakes cause the brake pads and discs to have a very short service life - Wet brakes are not affected by these conditions because they are fully encased in Oil
- Reduced maintenance cost
- NAF system in MT26/31 III has a big advantage. It does not require forced cooling like most competitors.
- There is no danger of sparks

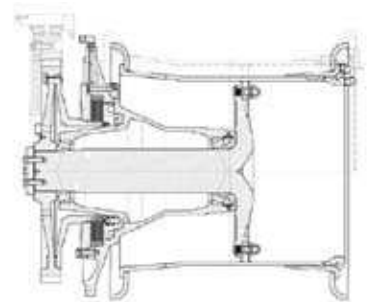

Operator's Comfort

- Cabin is equipped with air-conditioning and an operator seat with air-suspension
- Sloping hood provides an excellent view from the operator's position combined with good rear visibility
- Rubber suspension mounted for CABIN lead to low vibration levels
- "Tip-tronic" gearshift feature enables the operator to run the truck in both automatic and manual gear to ensure the smoothest possible gear-shift



New weight - saving bogie design
no need for tail gate increased payload

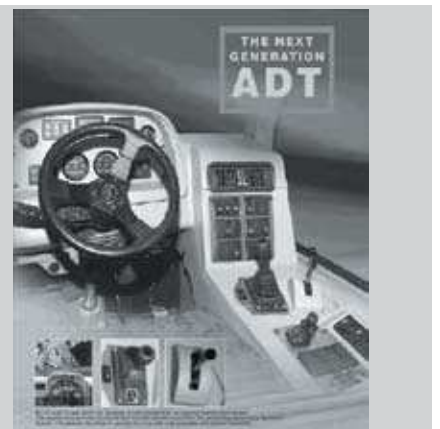

Dimensions & Technical specifications

MT 26 III

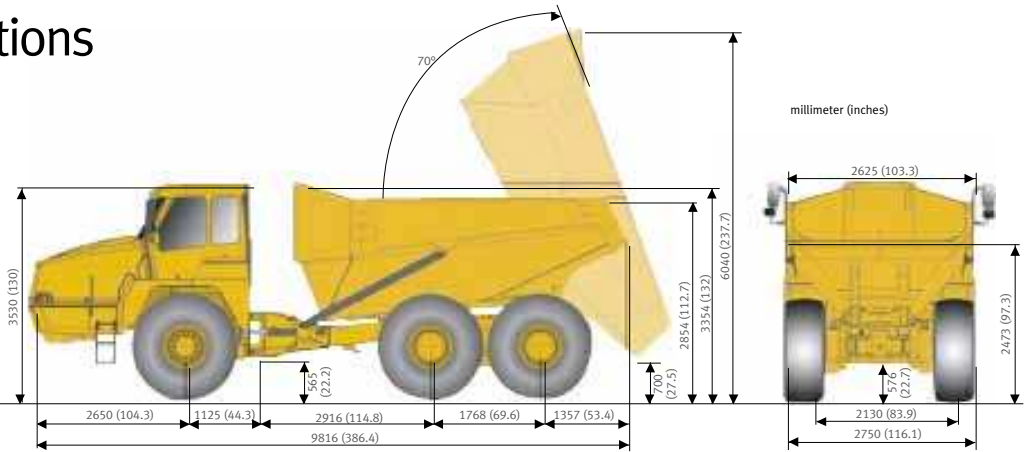

BODY

- Material: Hardened abrasion-resistant steel plates
- Tilt cylinders: Single stage, double-acting
- Tipping time: Up: 11 sec. / Down 10 sec.
- The body is designed for exhaust heating
- Sloping body down from the hinge point

	Cubic Yards	Cubic Meters
• Level capacity :	16	12
• Heaped capacity : (Acc. SAE J 1363, 2:1)	20	15
• Heaped capacity : (Acc. SAE J 1363, 1:1)	24	18

WEIGHTS

	LB	KG
Empty:		
Front axle	24,640	11,200
Rear axle	21,230	9,650
Loaded:		
Front axle	32,164	14,620
Rear axle	66,726	30,330
Pay load	53,020	24,100
Total weight (loaded)	98,890	44,950

NOTE: All weights include a full fuel tank and operator

GROUND PRESSURES

	PSI	kPa
Standard 23.5 x 25 tires with 15% sinkage		
Empty:		
Front axle	15.52	107
Rear axle	6.53	45
Loaded:		
Front axle	20.02	138
Rear axle	20.89	144

CAPACITIES

	U.S. GALLONS	LITERS
• Fuel Tank	84.5	320
• Hydraulic System	36.4	138
• Engine Cooling System	11.9	45
• Transmission	15.1	57
• Dropbox	8.7	33
• Engine Crankcase	3.5	13.2
• Front Reduction Gear	2 X 0.80	2 X 3
• Rear Differential	8.5	32
• Tandem Housing	2 X 19.8	2 X 75

SPEEDS

	MPH	KMH
1st	4	6
2nd	6	9
3rd	7	14
4th	14	22
5th	20	33
6th	32	51

SUSPENSION

- Front: Independent with long life rubber springs and hydraulic shock absorbers
- Rear: Free-swinging tandem housing

ARTICULATION HINGE AND STEERING

- Articulation hinge with forward mounted turning ring
- Steering cylinders (two): Double-acting
- The steering is approved according to ISO 5010
- Max. steering angle: 45°
- Ground driven emergency steering pump

DRIVE LINE

- Full-time 6 x 6 drive with two transverse differentials and one longitudinal
- Front axle transverse differential: Limited-slip with 45% locking ratio
- Rear axle transverse differential: Limited slip with 45% locking ratio
- Inter-axle longitudinal differential: Torque-proportioning differential, integrated into Torque distribution:
 - 1/3 to the front axle
 - 2/3 to the rear axle
 - 100% lockable
- Tandem housing: Gear driven, free-swinging. Provides equal drive to rear wheels and ensures the best possible ground contact - whatever the ground conditions

ENGINE

Scania DC 9, water-cooled, unit injected diesel engine with turbo charger and air to air intercooler

- Complies with Stage 3 of EU Directive 97/68/-EC and Tier 3 of USA/California regulations (ISO 8178) for emissions
- Power rating: (1.36 hp = 1 kW)
 - (ISO 3046) 310 hp (228 kW)
 - (ISO 9249) 299 hp (220 kW)
- No. of cylinders: 5 (in line)
- Cylinder volume: 549 cubic inches (9.0 liters)
- Air filter: Dry type

TRANSMISSION

ZF 6 WG 260 Dash 4 electronically-controlled automatic transmission the torque converter has automatic lock-up in all gears

BRAKE SYSTEM

- Dual circuit braking system acting on all six wheels
- Approved according to ISO 3450
- All hydraulic operated brakes with enclosed oil-cooled wet multiple discs all round
- Spring actuated hydraulic released parking brake, mounted on propeller shaft
- Max. gradient, parking brake: 20
- Automatic engine brake as standard
- Automatic transmission retarder as standard

HYDRAULIC SYSTEM

- Pumps: 2 variable displacement piston pumps :
 - for steering & tipping -
 - for cooling, fan, brakes & auxiliaries
- Delivery: 60.8 gallon/min (230 l/min) @ 2200 rpm
- Filtration: One return flow filter & high pressure filter
- Pressure-setting, main safety valves:
- Tipping Circuit: 4,061 PSI (280 bar)
- Steering Circuit: 3,046 PSI (210 bar)

ELECTRICAL SYSTEM

- Alternator: 28V 100A
- Batteries: (two): 12V 140Ah (series connected to give 24V) 5.4 HP (4.0 kW)
- Starter:

CAB

- Approved to ROPS/FOPS standards (ISO 3471, ISO 3449, SAE J 231 and SAE J1040 April '88)
- Low interior sound level 74 dB(A) (ISO 6394)
- The cab is centrally located on rubber mountings
- Hand and arm vibrations are less than 2.5 m/s according to ISO 5349-2
- Whole body vibration is less than 0.5 m/s according to ISO 2631-1
- Superior visibility - for safer operation
- Superior operating controls location
- Adjustable suspended operator seat
- Adjustable steering column
- Heater and Air Conditioning
- Tilting for service access

TIRES

- Standard 23.5 R25 two star radial

Turning radius according to ISO 7457 : 24.8 feet (7.56 m)

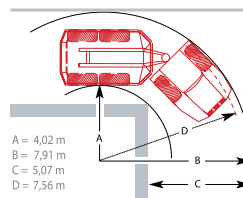

PERFORMANCE DIAGRAM

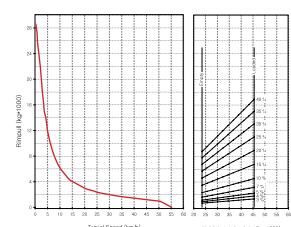

Dimensions & Technical specifications

MT 31 III

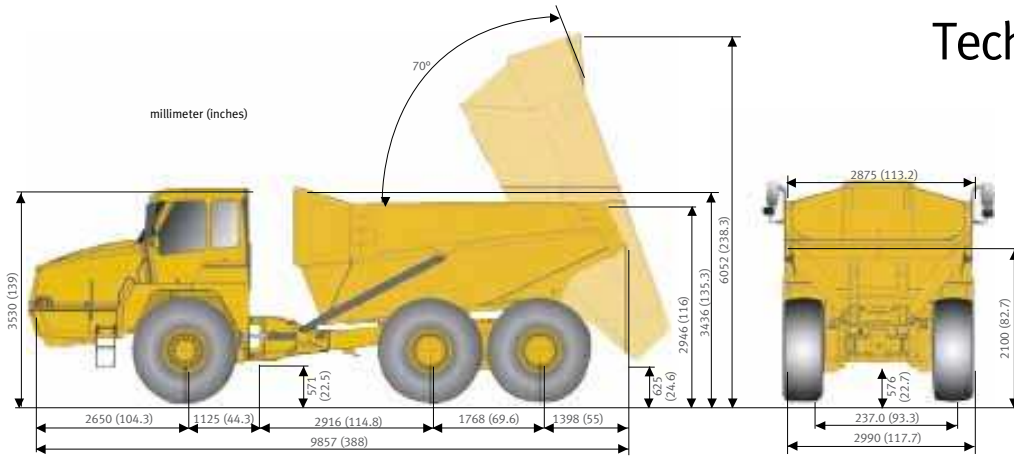

BODY

- Material: Hardened abrasion-resistant steel plates
- Tilt cylinders: Single stage, double-acting
- Tipping time: Up: 11 sec. / Down 10 sec.
- The body is designed for exhaust heating
- Sloping body down from the hinge point

	Cubic Yards	Cubic Meters
• Level capacity :	18	14
• Heaped capacity : (Acc. SAE J 1363, 2:1)	24	18
• Heaped capacity : (Acc. SAE J 1363, 1:1)	29	22

WEIGHTS

	LB	KG
Empty:		
Front axle	25,135	11,425
Rear axle	25,300	11,500
Loaded:		
Front axle	36,300	16,500
Rear axle	75,735	34,425
Pay load	61,600	28,000
Total weight (loaded)	112,035	50,925

NOTE: All weights include a full fuel tank and operator

GROUND PRESSURES

	PSI	kPa
Standard 23.5 x 25 tires with 15% sinkage		
Empty:		
Front axle	15.37	106
Rear axle	7.83	54
Loaded:		
Front axle	22.34	154
Rear axle	0.24	163

CAPACITIES

	U.S. GALLONS	LITERS
• Fuel Tank	92.4	350
• Hydraulic System	39.6	150
• Engine Cooling System	11.9	45
• Transmission	15.1	57
• Dropbox	8.7	33
• Engine Crankcase	3.5	13.2
• Front Reduction Gear	2 X 0.8	2 X 3
• Rear Differential	8.5	32
• Tandem Housing	2 X 19.8	2 X 75

SPEEDS

	MPH	KMH
1st	4	6
2nd	6	9
3rd	9	14
4th	14	22
5th	20	33
6th	32	51

SUSPENSION

- Front: Independent with long life rubber springs and hydraulic shock absorbers
- Rear: Free-swinging tandem housing

ARTICULATION HINGE AND STEERING

- Articulation hinge with forward mounted turning ring
- Steering cylinders (two): Double-acting
- The steering is approved according to ISO 5010
- Max. steering angle: 45°
- Ground driven emergency steering pump

DRIVE LINE

- Full-time 6 x 6 drive with two transverse differentials and one longitudinal
- Front axle transverse differential: Limited-slip with 45% locking ratio
- Rear axle transverse differential: Limited slip with 45% locking ratio
- Inter-axle longitudinal differential: Torque-proportioning differential, integrated into Torque distribution:
 - 1/3 to the front axle
 - 2/3 to the rear axle
 - 100% lockable
- Tandem housing: Gear driven, free-swinging. Provides equal drive to rear wheels and ensures the best possible ground contact - whatever the ground conditions

ENGINE

Scania DC 9, water-cooled, unit injected diesel engine with turbo charger and air to air intercooler

- Complies with Stage 3 of EU Directive 97/68/-EC and Tier 3 of USA/California regulations (ISO 8178) for emissions
- Power rating: (1.36 hp = 1 kW)
 - (ISO 3046) 347 hp (255 kW)
 - (ISO 9249) 336 hp (247 kW)
- No. of cylinders: 5 (in line)
- Cylinder volume: 549 cubic inches (9.0 liters)
- Air filter: Dry type

TRANSMISSION

ZF 6 WG 260 Dash 4 electronically-controlled automatic transmission the torque converter has automatic lock-up in all gears

BRAKE SYSTEM

- Dual circuit braking system acting on all six wheels
- Approved according to ISO 3450
- All hydraulic operated brakes with disc brakes all round
- Spring actuated hydraulic released parking brake, mounted on propeller shaft
- Max. gradient, parking brake: 20
- Automatic engine brake as standard
- Automatic transmission retarder as standard

HYDRAULIC SYSTEM

- Pumps: 2 variable displacement piston pumps : for steering & tipping - for cooling, fan, brakes & auxiliaries
- Delivery: 60.8 gallon/min (230 l/min) @ 2200 rpm
- Filtration: One return flow filter & high pressure filter
- Pressure-setting, main safety valves:
- Tipping Circuit: 3,046 PSI (280 bar)
- Steering Circuit: 4,061 PSI (210 bar)

ELECTRICAL SYSTEM

- Alternator: 28V 100A
- Batteries: (two): 12V 140Ah (series connected to give 24V) 5.4 HP (4.0 kW)
- Starter:

CAB

- Approved to ROPS/FOPS standards (ISO 3471, ISO 3449, SAE J 231 and SAE J1040 April '88)
- Low interior sound level 74 dB(A) (ISO 6394)
- The cab is centrally located on rubber mountings
- Hand and arm vibrations are less than 2.5 m/s according to ISO 5349-2
- Whole body vibration is less than 0.5 m/s according to ISO 2631-1
- Superior visibility - for safer operation
- Superior operating controls location
- Adjustable suspended operator seat
- Adjustable steering column
- Heater and Air Conditioning
- Tilting for service access

TIRES

- Standard 23.5 R25 two star radial

Turning radius according to ISO 7457 : 25.2 feet (7.68 m)

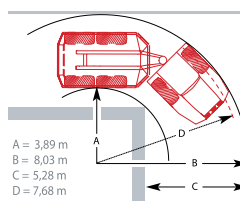

PERFORMANCE DIAGRAM

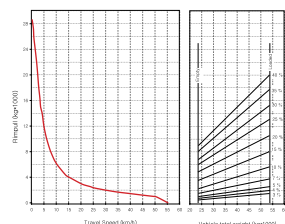

Dimensions & Technical specifications

MT 26

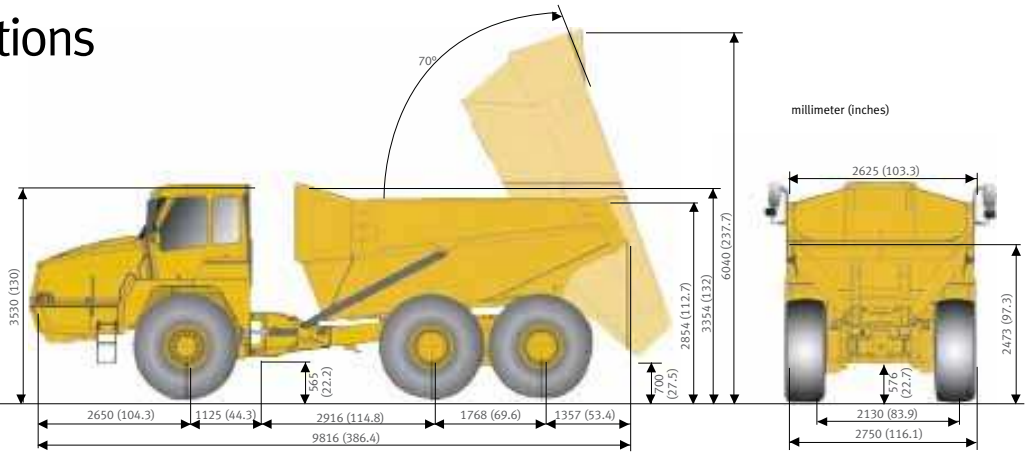

BODY

- Material: Hardened abrasion-resistant steel plates
- Tilt cylinders: Single stage, double-acting
- Tipping time: Up: 11 sec. / Down 10 sec.
- The body is designed for exhaust heating
- Sloping body down from the hinge point

	Cubic Yards	Cubic Meters
• Level capacity :	16	12
• Heaped capacity : (Acc. SAE J 1363, 2:1)	20	15
• Heaped capacity : (Acc. SAE J 1363, 1:1)	24	18

WEIGHTS

	LB	KG
Empty:		
Front axle	24,640	11,200
Rear axle	21,230	9,650
Loaded:		
Front axle	32,164	14,620
Rear axle	66,726	30,330
Pay load	53,020	24,100
Total weight (loaded)	98,890	44,950

NOTE: All weights include a full fuel tank and operator

GROUND PRESSURES

	PSI	kPa
Standard 23.5 x 25 tires with 15% sinkage		
Empty:		
Front axle	15.52	107
Rear axle	0.53	45
Loaded:		
Front axle	20.02	138
Rear axle	20.89	144

CAPACITIES

	U.S. GALLONS	LITERS
• Fuel Tank	84.5	320
• Hydraulic System	36.4	138
• Engine Cooling System	11.9	45
• Transmission	15.1	57
• Dropbox	8.7	33
• Engine Crankcase	3.5	13.2
• Front Reduction Gear	2 X 0.80	2 X 3
• Rear Differential	8.5	32
• Tandem Housing	2 X 19.8	2 X 75

SPEEDS

	MPH	KMH
1st	4	6
2nd	4	9
3rd	9	14
4th	14	22
5th	21	33
6th	32	51

SUSPENSION

- Front: Independent with long life rubber springs and hydraulic shock absorbers
- Rear: Free-swinging tandem housing

ARTICULATION HINGE AND STEERING

- Articulation hinge with forward mounted turning ring
- Steering cylinders (two): Double-acting
- The steering is approved according to ISO 5010
- Max. steering angle: 45°
- Ground driven emergency steering pump

DRIVE LINE

- Full-time 6 x 6 drive with two transverse differentials and one longitudinal
- Front axle transverse differential: Limited-slip with 45% locking ratio
- Rear axle transverse differential: Limited slip with 45% locking ratio
- Inter-axle longitudinal differential: Torque-proportioning differential, integrated into Torque distribution:
 - 1/3 to the front axle
 - 2/3 to the rear axle
 - 100% lockable
- Tandem housing: Gear driven, free-swinging. Provides equal drive to rear wheels and ensures the best possible ground contact - whatever the ground conditions

ENGINE

Scania DC 9, water-cooled, unit injected diesel engine with turbo charger and air to air intercooler

- Complies with Stage 3 of EU Directive 97/68/-EC and Tier 3 of USA/California regulations (ISO 8178) for emissions
- Power rating: (1.36 hp = 1 kW)
 - (ISO 3046) 310 hp (228 kW)
 - (ISO 9249) 299 hp (220 kW)
- No. of cylinders: 5 (in line)
- Cylinder volume: 549 cubic inches (9.0 liters)
- Air filter: Dry type

TRANSMISSION

ZF 6 WG 260 Dash 4 electronically-controlled automatic transmission the torque converter has automatic lock-up in all gears

BRAKE SYSTEM

- Dual circuit braking system acting on all six wheels
- Approved according to ISO 3450
- All hydraulic operated brakes with enclosed oil-cooled wet multiple discs all round
- Spring actuated hydraulic released parking brake, mounted on propeller shaft
- Max. gradient, parking brake: 20
- Automatic engine brake as standard
- Automatic transmission retarder as standard

HYDRAULIC SYSTEM

- Pumps: 2 variable displacement piston pumps : for steering & tipping - for cooling, fan, brakes & auxiliaries 60.8 gallon/min (230 l/min) @ 2200 rpm One return flow filter & high pressure filter
- Delivery:
- Filtration:
- Pressure-setting, main safety valves: 4,061 PSI (280 bar)
- Tipping Circuit: 3,046 PSI (210 bar)
- Steering Circuit:

ELECTRICAL SYSTEM

- Alternator: 28V 100A
- Batteries: (two): 12V 140Ah (series connected to give 24V) 5.4 HP (4.0 kW)
- Starter:

CAB

- Approved to ROPS/FOPS standards (ISO 3471, ISO 3449, SAE J 231 and SAE J1040 April '88)
- Low interior sound level 74 dB(A) (ISO 6394)
- The cab is centrally located on rubber mountings
- Hand and arm vibrations are less than 2.5 m/s according to ISO 5349-2
- Whole body vibration is less than 0.5 m/s according to ISO 2631-1
- Superior visibility - for safer operation
- Superior operating controls location
- Adjustable suspended operator seat
- Adjustable steering column
- Heater and Air Conditioning
- Tilting for service access

TIRES

- Standard 23.5 R25 two star radial

Turning radius according to ISO 7457 : 24.8 feet (7.56 m)

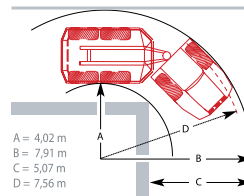

PERFORMANCE DIAGRAM

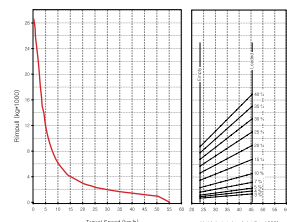

Dimensions & Technical specifications

MT 36

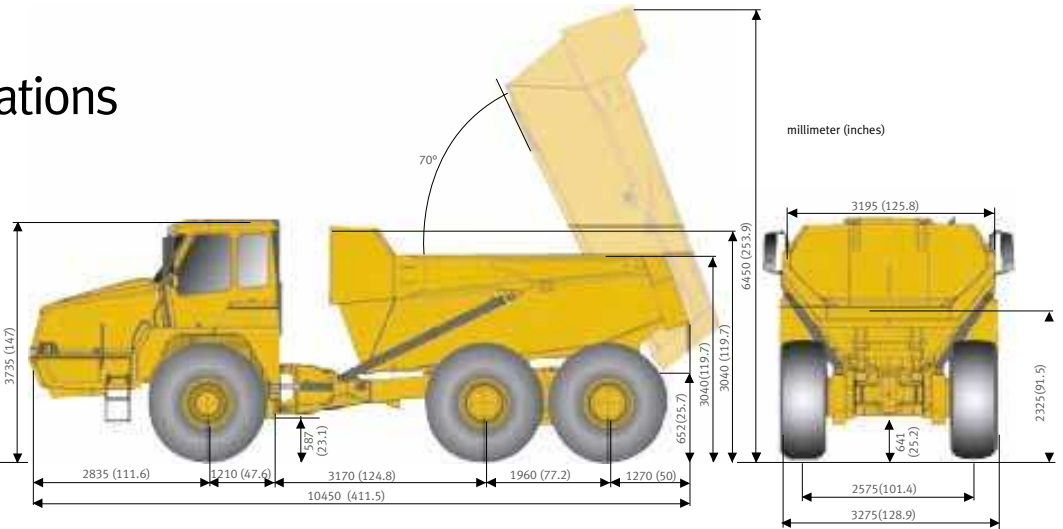

BODY

- Material: Hardened abrasion-resistant steel plates
- Tilt cylinders: Single stage, double-acting
- Tipping time: Up: 12 sec. / Down 11 sec.
- The body is designed for exhaust heating
- Sloping body down from the hinge point

	Cubic Yards	Cubic Meters
• Level capacity :	21	16
• Heaped capacity : (Acc. SAE J 1363, 2:1)	27	21
• Heaped capacity : (Acc. SAE J 1363, 1:1)	34	26

WEIGHTS

	LB	KG
Empty:		
Front axle	29,480	13,400
Rear axle	29,260	13,300
Loaded:		
Front axle	42,900	19,500
Rear axle	87,780	39,900
Pay load	71,940	32,700
Total weight (loaded)	130,680	59,400

NOTE: All weights include a full fuel tank and operator

GROUND PRESSURES

	PSI	kPa
Standard 26.5 x 25 tires with 15% sinkage		
Empty:		
Front axle	15.66	108
Rear axle	8.99	62
Loaded:		
Front axle	23.21	160
Rear axle	24.66	170

CAPACITIES

	U.S. GALLONS	LITERS
• Fuel Tank	112.2	425
• Hydraulic System	66.0	250
• Engine Cooling System	13.2	50
• Transmission	14.5	55
• Dropbox	9.0	34
• Engine Crankcase	3.5	13.2
• Front Reduction Gear	2 X 2	2 X 7.5
• Rear Differential	12.1	46
• Tandem Housing	2 X 40	2 X 150

SPEEDS

	MPH	KMH
1st	4	6
2nd	6	9
3rd	9	14
4th	14	22
5th	20	32
6th	32	51

SUSPENSION

- Front: Independent with long life rubber springs and hydraulic shock absorbers
- Rear: Free-swinging tandem housing

ARTICULATION HINGE AND STEERING

- Articulation hinge with forward mounted turning ring
- Steering cylinders (two): Double-acting
- The steering is approved according to ISO 5010
- Max. steering angle: 45°
- Ground driven emergency steering pump

DRIVE LINE

- Full-time 6 x 6 drive with two transverse differentials and one longitudinal
- Front axle transverse differential: Limited-slip with 45% locking ratio
- Rear axle transverse differential: Limited slip with 45% locking ratio
- Inter-axle longitudinal differential: Torque-proportioning differential, integrated into Torque distribution:
 - 1/3 to the front axle
 - 2/3 to the rear axle
 - 100% lockable
- Tandem housing: Gear driven, free-swinging.
- Provides equal drive to rear wheels and ensures the best possible ground contact - whatever the ground conditions

ENGINE

- Scania DC 12, water-cooled, unit injected diesel engine with turbo charger and air to air intercooler
- Complies with Stage 3 of EU Directive 97/68/-EC and Tier 3 of USA/California regulations (ISO 8178) for emissions
- Power rating: (1.36 hp = 1 kW)
 - (ISO 3046) 400 hp (294 kW)
 - (ISO 9249) 388 hp (285 kW)
- No. of cylinders: 6 (in line)
- Cylinder volume: 714 cubic inches (11.7 liters)
- Air filter: Dry type

TRANSMISSION

- ZF 6 WG 310 Dash 4 electronically-controlled automatic transmission
- the torque converter has automatic lock-up in all gears

BRAKE SYSTEM

- Dual circuit braking system acting on all six wheels
- Approved according to ISO 3450
- All hydraulic operated brakes with enclosed oil-cooled wet multiple discs all round
- Spring actuated hydraulic released parking brake, mounted on propeller shaft
- Max. gradient, parking brake: 20
- Automatic engine brake as standard
- Automatic transmission retarder as standard

HYDRAULIC SYSTEM

- Pumps: 2 variable displacement piston pumps : for steering & tipping - for cooling, fan, brakes & auxiliaries
- Delivery: 84.5 gallon/min (320 l/min) @ 2200 rpm
- Filtration: One return flow filter & high pressure filter
- Pressure-setting, main safety valves:
- Tipping Circuit: 4,061 PSI (280 bar)
- Steering Circuit: 3,046 PSI (210 bar)

ELECTRICAL SYSTEM

- Alternator: 28V 100A
- Batteries: (two): 12V 225Ah (series connected to give 24V) 9 HP (6.7 kW)
- Starter:

CAB

- Approved to ROPS/FOPS standards (ISO 3471, ISO 3449, SAE J 231 and SAE J1040 April '88)
- Low interior sound level 74 dB(A) (ISO 6394)
- The cab is centrally located on rubber mountings
- Hand and arm vibrations are less than 2.5 m/s according to ISO 5349-2
- Whole body vibration is less than 0.5 m/s according to ISO 2631-1
- Superior visibility - for safer operation
- Superior operating controls location
- Adjustable suspended operator seat
- Adjustable steering column
- Heater and Air Conditioning
- Tilting for service access

TIRES

- Standard 26.5 R25 two star radial

Turning radius according to ISO 7457 : 27.5 feet (8.37 m)

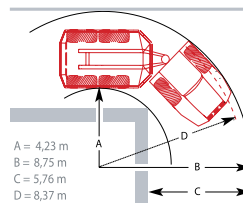

PERFORMANCE DIAGRAM

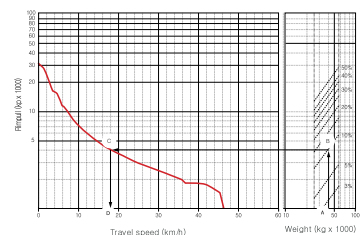

Dimensions & Technical specifications

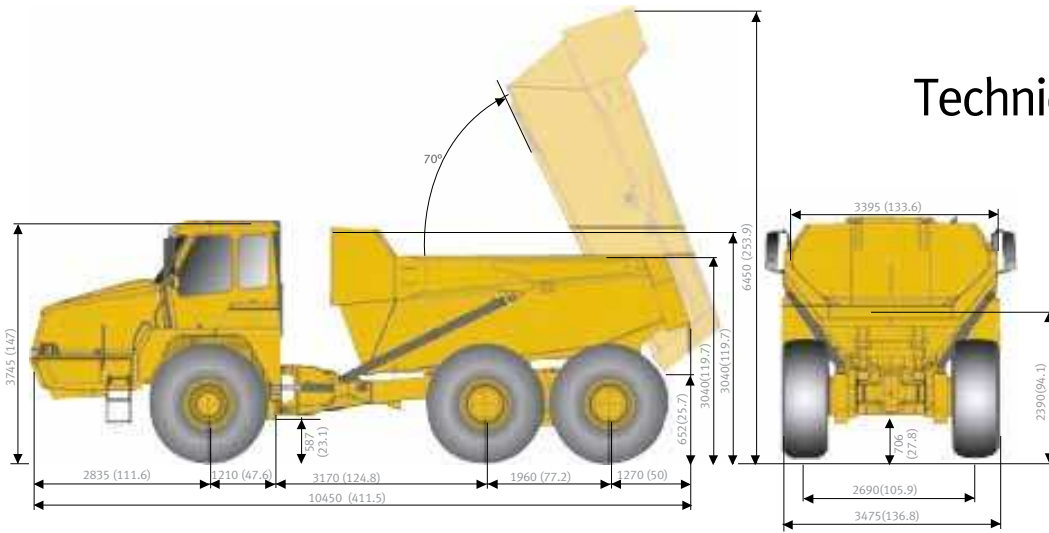

MT 41

BODY

- Material: Hardened abrasion-resistant steel plates
- Tilt cylinders: Single stage, double-acting
- Tipping time: Up: 12 sec. / Down 11 sec.
- The body is designed for exhaust heating
- Sloping body down from the hinge point

	Cubic Yards	Cubic Meters
• Level capacity :	24	18.5
• Heaped capacity : (Acc. SAE J 1363, 2:1)	31	24
• Heaped capacity : (Acc. SAE J 1363, 1:1)	38	29

WEIGHTS

	LB	KG
Empty:		
Front axle	30,690	13,950
Rear axle	29,038	13,200
Loaded:		
Front axle	44,000	20,000
Rear axle	97,568	44,350
Pay load	81,840	37,200
Total weight (loaded)	141,568	64,350

NOTE: All weights include a full fuel tank and operator

GROUND PRESSURES

	PSI	kPa
Standard 29.5 x 25 tires with 15% sinkage		
Empty:		
Front axle	12.76	88
Rear axle	6.96	48
Loaded:		
Front axle	18.85	130
Rear axle	22.05	152

CAPACITIES

	U.S. GALLONS	LITERS
• Fuel Tank	129	490
• Hydraulic System	73	275
• Engine Cooling System	13	50
• Transmission	14.5	55
• Dropbox	9	34
• Engine Crankcase	3.5	13.2
• Front Reduction Gear	2 X 2	2 X 7.5
• Rear Differential	12	46
• Tandem Housing	2 X 40	2 X 150

SPEEDS	MPH	KMH
1st	4	6
2nd	6	9
3rd	9	15
4th	14	23
5th	21	34
6th	33	53

SUSPENSION

- Front: Independent with long life rubber springs and hydraulic shock absorbers
- Rear: Free-swinging tandem housing

ARTICULATION HINGE AND STEERING

- Articulation hinge with forward mounted turning ring
- Steering cylinders (two): Double-acting
- The steering is approved according to ISO 5010
- Max. steering angle: 45°
- Ground driven emergency steering pump

DRIVE LINE

- Full-time 6 x 6 drive with two transverse differentials and one longitudinal
- Front axle transverse differential: Limited-slip with 45% locking ratio
- Rear axle transverse differential: Limited slip with 45% locking ratio
- Inter-axle longitudinal differential: Torque-proportioning differential, integrated into Torque distribution:
 - 1/3 to the front axle
 - 2/3 to the rear axle
 - 100% lockable
- Tandem housing: Gear driven, free-swinging. Provides equal drive to rear wheels and ensures the best possible ground contact - whatever the ground conditions

ENGINE

Scania DC 12, water-cooled, unit injected diesel engine with turbo charger and air to air intercooler

- Complies with Stage 3 of EU Directive 97/68/-EC and Tier 3 of USA/California regulations (ISO 8178) for emissions
- Power rating: (1.36 hp = 1 kW)
 - (ISO 3046) 450 hp (331 kW)
 - (ISO 9249) 438 hp (322kW)
- No. of cylinders: 6 (in line)
- Cylinder volume: 714 cubic inches (11.7 liters)
- Air filter: Dry type

TRANSMISSION

ZF 6 WG 310 Dash 4 electronically-controlled automatic transmission the torque converter has automatic lock-up in all gears

BRAKE SYSTEM

- Dual circuit braking system acting on all six wheels
- Approved according to ISO 3450
- All hydraulic operated brakes with enclosed oil-cooled wet multiple discs all round
- Spring actuated hydraulic released parking brake, mounted on propeller shaft
- Max. gradient, parking brake: 20
- Automatic engine brake as standard
- Automatic transmission retarder as standard

HYDRAULIC SYSTEM

- Pumps: 2 variable displacement piston pumps :
 - 1for steering & tipping -
 - 1for cooling, fan, brakes & auxiliaries
- Max Capacity : 84.5 gallon/min (320 l/min) @ 2200 rpm
- Filtration: One return flow filter & high pressure filter
- Safety valve settings: Steering: 3,046 PSI (210 bar)
- Tipping: 4,061 PSI (280 bar)

ELECTRICAL SYSTEM

- Alternator: 28V 100A
- Batteries: (two): 12V 225Ah (series connected to give 24V) 9.1 HP (6.7 kW)
- Starter:

CAB

- Approved to ROPS/FOPS standards (ISO 3471, ISO 3449, SAE J 231 and SAE J1040 April '88)
- Low interior sound level 74 dB(A) (ISO 6394)
- The cab is centrally located on rubber mountings
- Hand and arm vibrations are less than 2.5 m/s according to ISO 5349-2
- Whole body vibration is less than 0.5 m/s according to ISO 2631-1
- Superior visibility - for safer operation
- Superior operating controls location
- Adjustable suspended operator seat
- Adjustable steering column
- Heater and Air Conditioning
- Tilting for service access

TIRES

- Standard 29.5 R25 two star radial

Turning radius according to ISO 7457 : 27.6 feet (8.42 m)

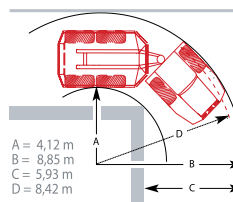

PERFORMANCE DIAGRAM

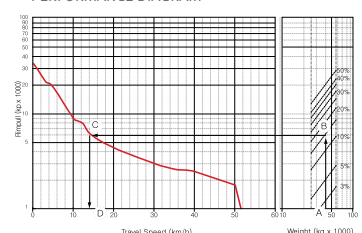

NOTES



Doosan Infracore America Corporation

2905 Shawnee Industrial Way
Suwanee, Georgia 30024, U. S. A.
Tel : +1-770-831-2200
Fax : +1-770-831-0480

www.doosaninfracore.com
www.doosanmoxy.com

Doosan Infracore Europe S.A.

1A, Rue Achille Degrace, 7080 Frameries, Belgium
Tel : +32-65-61-3230 Fax : +32-65-67-7338

Doosan Infracore U.K., Ltd.

Doosan House, Unit 6, 3 Heol Y Gamlas, Parc Nantgarw, Nantgarw,
Cardiff. CF15 7QU, U.K.
Tel : +44-1443-84-2273 Fax : +44-1443-84-1933

Doosan Infracore Europe S.A. Germany

Heinrich-von-Stephan str. 2 40764 Langenfeld, Germany
Tel : +49-2173-2035-210 Fax : +49-2173-2035-219

Doosan Infracore France

ZAC de La Clef Saint Pierre - Buroplus 2 1A Avenue Jean d'Alembert
78990 Elancourt, France
Tel : +33-(0)1-30-16-21-41 Fax : +33-(0)1-30-16-21-44

Doosan Infracore Seoul Office

Doosan Tower 27th FL.18-12, Euljiro-6 Ga, Jung-Gu, Seoul, Korea 100-730
Tel : +82-2-3398-8049 Fax : +82-2-3398-8117

Doosan Infracore China Co., Ltd.

#28, Wuzhishan Road, Eco. & Tech, Development Zone, Yantai, Shandong, China
Tel : +86-535-638-2000 Fax : +86-535-638-2004

Doosan Infracore Russia

123242, Moscow, Kapranova Lane, bld.3, office 402, 4-th floor
Business Centre "Premier Plaza"
Tel: +7 (495)663 82 38/ (499) 923 12 55 Fax: +7 (495) 663 82 39

Doosan Infracore Middle East Center (Dubai)

P.O.Box 183127, Al-Serkal Building, Air Port Road, Dubai, U.A.E
Tel : +971-4-295-2781~2 Fax :+971-4-295-2783

Doosan Infracore do Brasil ServiCos de Suporte Comercial Ltda.

Alameda Santos 2222 Cj52 CEP 01418.200 Sao Paulo, SP, Brasil
Tel : +55-11-3061-3227 Fax : +55-11-3061-2731

Doosan Infracore India Pvt.Ltd

Plot No. 34, Door No. 1/61-19, Palwels street, Ravi Colony,
St. Thomas Mount, Chennai-600 016
Tel : +91-44-4222-3900 Fax : +91-44-4222-3905



ILD MOXY000 0810

The illustrations do not necessary show the product in standard version.
All products and equipment are not available in all markets.
Materials and specifications are subject to change without prior notice.