



DOOSAN. POWERFUL SOLUTIONS.



Portable Air Compressors
185 — 1600 cfm

DOOSAN

Courtesy of Machine.Market

Table of Contents

- About Us 1
- Powerful Solutions 2
- P Series 3-4
 - P185
 - P185 Utility/XP185 Utility
 - P250/HP185
- C Series 5-6
 - C185
 - C185 Gas
- Medium Air 7-8
 - P425/HP375
 - HP450/VHP400
- Large Air 9-10
 - XP825/HP750
 - VP900e
- Extra Large Air/
Low Pressure 11-12
 - HP915
 - XP1000
 - HP1600
- Extra Large Air/
High Pressure 13-14
 - XHP750
 - XHP1000
 - XHP1170
- Drill Modules 15
- IQ System 16
- Specifications 17-21



DOOSAN

About Us

Doosan Portable Power has more than 100 years of manufacturing expertise and application experience, with a focus on providing the highest quality machines with unrivaled customer service. Our market leading product line of portable air compressors, generators and light towers are proudly built in the USA. Doosan Portable Power is headquartered in Statesville, North Carolina, and was established in 2007 when Doosan Infracore purchased Ingersoll-Rand's Utility Equipment division.

Today, Doosan Portable Power is a subsidiary of Doosan Bobcat Inc. Doosan Bobcat is an industry leader in the engineering, manufacturing and marketing of construction equipment, and also represents the Bobcat and Doosan Heavy Equipment brands. Doosan Bobcat is committed to delivering innovative products and services that provide quality and value.





Powerful Solutions

At Doosan Portable Power, we do more than provide superior products. We deliver powerful solutions to move your business forward. Robust compressors that perform on the most demanding job sites. Generators and light towers that are reliable and efficient. Factor in our industry-leading service and support, and it's quite clear that partnering with us is a smart return on your investment.

Dependability

Our equipment is built to last with corrosion-resistant galvanized steel enclosures and a durable, baked-on powder coat finish. Extensive testing at our Statesville, North Carolina facility includes a test track, tilt table, and cold chamber to ensure our machines will perform in the harshest conditions and applications.

Doosan is fully committed to delivering quality machines that maximize uptime and minimize downtime to give you peace of mind.

“The quality is a 10. The durability is a 10.”

-Jack Anderson, Pape Material Handling

Performance

Doosan Portable Power gives you the power you need in the most efficient manner. We provide leading fuel economy and performance while ensuring compliance with the latest emissions standards.

Doosan also offers unmatched versatility to support almost every job or application. And with user friendly controls and diagnostics, anyone can operate our equipment with minimal instruction.

“Doosan has always performed well for us.”

-Mark Grimes, Industrial Marine

Serviceability

Doosan has an extensive and knowledgeable dealer network. Our dealer-partners have a deep understanding of your business and can provide the solutions you demand.

All of our products are engineered and designed with an emphasis on accessibility to make sure routine maintenance is quick and easy to perform without having to take the machine apart.

“Parts and service are always there when we need it.”

- Mike Venuti, Meruelo Group



The industry's largest and deepest, full-length toolbox provides over 8,700 cubic inches of convenient tool and accessory storage.



The high performance Doosan D24 engine features a diesel oxidation catalyst (DOC) aftertreatment system, which is virtually maintenance-free.

P185

Full specifications on page 18



FREE AIR DELIVERY | PRESSURE

185 cfm (5.2 m³/min) | 100 psig (6.9 bar)

With the most available options in the industry, the P185 can be customized to meet any job site need. This durable workhorse is powered by a Doosan D24 engine with a diesel oxidation catalyst (DOC) after-treatment system which is virtually maintenance-free.

The high-performance Doosan engine provides the P185 with reliable power, over 10 hours of run-time, and improved cold-starting capability. Its spin-on oil separation system offers the easiest and quickest maintenance in the industry. The P185 also boasts the industry's largest, deepest, full-length toolbox, providing you with over 8,700 cubic inches of storage.

P185 Utility / XP185 Utility

Full specifications on page 18



FREE AIR DELIVERY | PRESSURE

P: 185 cfm (5.2 m³/min) | 100 psi (7.0 bar)
XP: 185 cfm (5.2 m³/min) | 125 psi (8.6 bar)

The P185 and XP185 utility compressors set the standard for skid-mounted, space-saving solutions. Designed for above-deck installation and packaged with assorted options, the P185 utility blends performance and serviceability with curbside, digital controls and gauges. This quick-view, eye-level access improves safety and convenience.

The XP185 can simultaneously power both air and electrical tools when outfitted with an optional 4kW generator. An efficient, high performance Doosan D24 engine delivers 49 HP (P185) and 72 HP (XP185), and a runtime of 10 hrs (P185) and 7.48 hrs (XP185). The engine's limiting air temperature (LAT) of 130°(P185) and 125°(XP185), helps maximize uptime in hot conditions.

P250 / HP185

Full specifications on page 18



FREE AIR DELIVERY | PRESSURE

250 cfm (7.0 m³/min) / 185 cfm (5.2 m³/min)
100 psi (6.9 bar) / 150 psi (10.3 bar)

With dual-pressure and flow ratings, the indispensable P250/HP185 serves as two compressors in one. Able to increase productivity for a wide variety of jobs, including general construction, abrasive blasting and pipeline pressure testing, the unit is also ideal for powering hand-held pneumatic tools.

A robust frame, drawbar and independent suspension assures stability on and off the road. Electro-thermostatically controlled cooling fans match fuel efficiency with low noise, and DOC engine after-treatment provides a maintenance-free solution for Tier 4 final emissions. In addition, LED backlit gauges and durable engine start/push controls promote long-term, user-friendly operation.

DOOSAN. POWERFUL SOLUTIONS.

DoosanPortablePower.com
800.727.8457



DOOSAN

C185

6099

49
HYDROPOWER



Easy access canopy can open to one position for routine checks and service, and a full-open position for more involved service and maintenance.



Spin-on oil separation system for the easiest maintenance in the industry. Element changes are reduced to two minutes.

C185

Full specifications on page 19



FREE AIR DELIVERY | PRESSURE

185 cfm (5.2 m³/min) | 100 psig (6.9 bar)

For reliable power in a cost-efficient machine, turn to the C185. Packed with quality, performance and serviceability for a wide variety of jobs, the C185 delivers unmatched value and a small footprint for effortless towing and maneuverability.

Inside, a simple spin-on separator element expedites service and maintenance, while cool-box airflow directs heat away from the unit to prolong life and minimize dust recirculation. Outside, the C185's two-position polymer canopy combines strength with easy-access for routine service and checks, while an ample toolbox conveniently stores tools and accessories.

C185 Gas

Full specifications on page 19



FREE AIR DELIVERY | PRESSURE

185 cfm (5.2 m³/min) | 100 psig (6.9 bar)

With reduced noise emissions and less weight (than diesel units), and outstanding cold starting capability, the C185G lends itself to a wide variety of jobs. Powered by a 2.5-liter, fuel-injected Kubota engine, the C185G delivers 6.4 hours of runtime at full load without sacrificing power or durability.

A unique cool-box design minimizes internal temperatures to protect components and tools, while a simple, intuitive control interface assures easy operation. For even greater value and long-term rental use, the unit's single piece, lightweight composite canopy is virtually indestructible.

DOOSAN. POWERFUL SOLUTIONS.

DoosanPortablePower.com
800.727.8457



P425
HP375

DOOSAN

DOOSAN

6000 AMP/480V 3PH/4W
15000 RPM/1800 RPM

P425/HP375

Full specifications on page 19



FREE AIR DELIVERY | PRESSURE

425 cfm (12 m³/min) / 375 cfm (10.6 m³/min)
100 psig (7 bar) / 150 psig (10.3 bar)



An electronically controlled engine-driven cooling fan with a hydraulic clutch improves fuel efficiency and reduces noise.

HP450/VHP400

Full specifications on page 19



FREE AIR DELIVERY | PRESSURE

450 cfm (12.7 m³/min) / 400 cfm (11.3 m³/min)
150 psig (10.3 bar) / 200 psig (13.8 bar)



The Doosan designed and manufactured DSN275 airend is efficient and delivers the high-volume cfm output to power applications like sand blasting.

Powered by a reliable Cummins 4.5L engine, the P425 and HP450 pair performance with productivity. A corrosion-resilient galvanized steel enclosure, A-frame drawbar, and heavy-duty axles promote durability, as a thermostatic cooling fan reduces noise and cuts fuel costs by an average 10% (in cold weather conditions).

With dual pressure and flow options, each compact unit easily switches from low- to high-pressure, meeting the needs of a wide range of applications. A five-gallon diesel exhaust fluid tank, small footprint and state-of-the-art control panel ease user operation, and Doosan's highly efficient airend demands less horsepower for high-volume cfm output.

DOOSAN. POWERFUL SOLUTIONS.

DoosanPortablePower.com
800.727.8457



RBI4072

DOOSAN

VP900e

4500 LBS

GALVANNEALD STEEL
FOR
PROLONGED CORROSION RESISTANCE

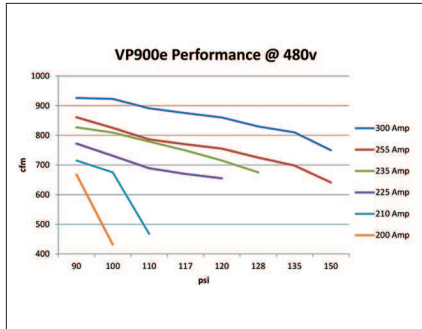

The Variable Frequency Drive (VFD) on the VP900e automatically adjusts the output of air flow to ever changing demands, saving significant power costs.



The redesigned control panel on the XP825/HP750 provides improved operator interface and easy-to-understand diagnostics.

XP825/HP750

Full specifications on page 20



FREE AIR DELIVERY | PRESSURE

825 cfm (23.4 m³/min) / 750 cfm (21.2 m³/min)
125 psig (8.6 bar) / 150 psig (10.3 bar)

Intuitive machine diagnostics, low cost of ownership and job flexibility define the XP825/HP750. Backed by a Cummins engine, corrosion-resilient steel enclosure, and robust drawbar and axles, this durable model lets operators change from low- to high-pressure at the touch of a button.

As a thermostatic, clutch-driven cooling fan minimizes noise and fuel costs, a 100-gallon fuel tank delivers nine hours of runtime. Doosan's high-efficiency airend offers high-volume cfm output with less horsepower. And a diesel oxidation catalyst with selective catalytic reduction virtually eliminates emissions maintenance with no regeneration cycles.

VP900e

Full specifications on page 21



FREE AIR DELIVERY | PRESSURE

750 cfm (21.2 m³/min) | 150 psig (10.3 bar)

The highly efficient, electric VP900e marks a new generation of portable air compressors. Intelligently engineered, the VP900e operates between 400 and 900 cfm with no wasted energy and no emissions, plus offers infinite variable pressure from 80 to 150 psi—an industry first.

At the system's core, a variable frequency drive matches motor performance to power demand, reducing energy costs. Environmentally friendly, the VP900e is ultra-quiet and features an innovative, full-color interface. Heavy-duty running gear with an extended-life, slipper-spring system protects the unit during towing.

DOOSAN. POWERFUL SOLUTIONS.

DoosanPortablePower.com
800.727.8457



HP915

Full specifications on page 20



FREE AIR DELIVERY | PRESSURE

915 cfm (25.9 m³/min) | 150 psig (10.3 bar)

XP1000

Full specifications on page 20



FREE AIR DELIVERY | PRESSURE

1000 cfm (28.3 m³/min) | 125 psig (8.6 bar)

Built to excel in rugged conditions, the HP915 and XP1000 offer unparalleled serviceability for maximum uptime. Panels on all unit sides afford ready access to service components. Operation is equally easy with centralized tubing and valves to conveniently drain fluids, oil and fuel, and a detailed control panel with more preloaded resources than any other model.

Compact yet powerful, the unit offers 9.25 hours of runtime and Doosan's patented IQ system for instrument-quality air and zero-discharge condensate removal.



We offer clean air systems—compressors, aftercoolers and water separation— that enable you to precisely meet ISO standards for your industry.

HP1600

Full specifications on page 20



FREE AIR DELIVERY | PRESSURE

1600 cfm (45.3 m³/min) | 150 psig (10.3 bar)

Designed for long-term use and maximum productivity, the HP1600 packs advanced power and features in a modest footprint. The industry's first 1,600 cfm compressor with a fuel-efficient Tier 4 Cummins QSX15 engine, the HP1600 balances 580 horsepower at 1,800 rpm with quiet operation.

An environmentally friendly containment basin offers 110% fluid containment, and Doosan's coolbox is designed to prolong system life and eliminate lengthy cool-downs. An enhanced ViewPort control panel, easy access to manuals, full-color back-lit LED displays, and industry-leading service intervals streamline machine operation.



DOOSAN. POWERFUL SOLUTIONS.

DoosanPortablePower.com
800.727.8457



The enclosure design of the XHP750 provides industry-leading accessibility for ease of service and maintenance.

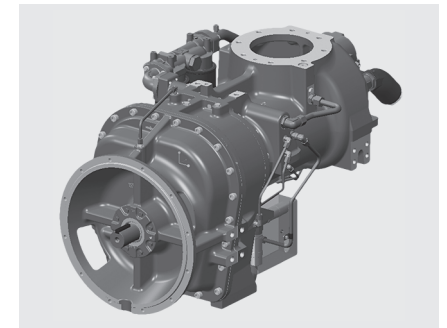

The XHP750, XHP1000 and XHP1170 models are equipped with a Doosan HR350 air end that requires less horsepower to deliver a high volume cfm output.

XHP750

Full specifications on page 21



FREE AIR DELIVERY | PRESSURE

750 cfm (21.2 m³/min)
140 – 365 psi (9.7 – 24.1bar)

The XHP750 provides high pressure air in the smallest package in the industry. Exterior design includes gull-wing doors, drop-down tailgate, and a cooler access hatch to provide the industry's best servicing capability.

Intuitive joystick control, instant access to 15 operational parameters, a built-in machine maintenance schedule, and handy spare parts and manual information simplify operation further.

XHP1000

Full specifications on page 21



FREE AIR DELIVERY | PRESSURE

1000 cfm (28.3 m³/min)
365 psi (25.1 bar)

Dual-pressure regulation comes standard in the XHP1000, offering operators 250 or 365 psi with the twist of a knob. An efficient central drain system allows operators to drain radiator fluid, oil and fuel to a central location without crawling under the machine.

Environmentally astute, the XHP1000's containment basin provides 110 percent fluid containment to capture and prevent fuel or oil spillage.

XHP1170

Full specifications on page 21



FREE AIR DELIVERY | PRESSURE

1170 cfm (33.1 m³/min)
365 psig (25.1 bar)

The industry's first Tier4 Final-compliant high-pressure air compressor with dual pressure of 250 or 365 psi, the XHP1170 houses premium features without the added cost. Fitted with a Doosan-manufactured HR350 airend, the unit delivers a high volume of air with less horsepower for 5% greater fuel economy.

A powerful Cummins QSX15 engine includes a selective catalytic reduction (SCR) and diesel particulate filter (DPF) after-treatment system. Twin, over 100 gallon fuel tanks combine for eight hours of runtime at 100% load.

DOOSAN. POWERFUL SOLUTIONS.

DoosanPortablePower.com
800.727.8457



Drill Modules

Doosan Portable Power offers a full line of drill modules from low pressure to high pressure to meet all your requirements for drilling. These reliable and robust modules are built to perform and deliver a solid return on your investment.

- Heavy-duty, single and two-stage rotary screw compressors are designed for mobile applications.
- Single-stage rotary screw compressor modules feature a hydraulically driven fan for oil cooling.
- Two-stage, high-pressure modules offer choice of shaft drive (CM or CMH) or direct engine coupling (CMH only).
- All packages are built with a heavy-gauge sheet metal housing for durability, and external airend lines are made of steel tubing to ensure a long life.
- User-friendly instrumentation includes analog gauges for separator discharge pressure and airend discharge temperature.
- Shutdown switches have been installed for airend and separator discharge temperature (normally closed at 248°F).
- Modules are designed to provide easy access for maintenance and serviceability.

SINGLE-STAGE ROTARY SCREW MODULES

RATED CAPACITY – cfm (m³/min)
300 (8.5) to 500 (14.2)

PRESSURE – psi (bar)
200 (13.8)

TWO-STAGE HIGH PRESSURE MODULES

RATED CAPACITY – cfm (m³/min)
750 (21.2) to 1250 (35.4)

PRESSURE – psi (bar)
350 (24.1)



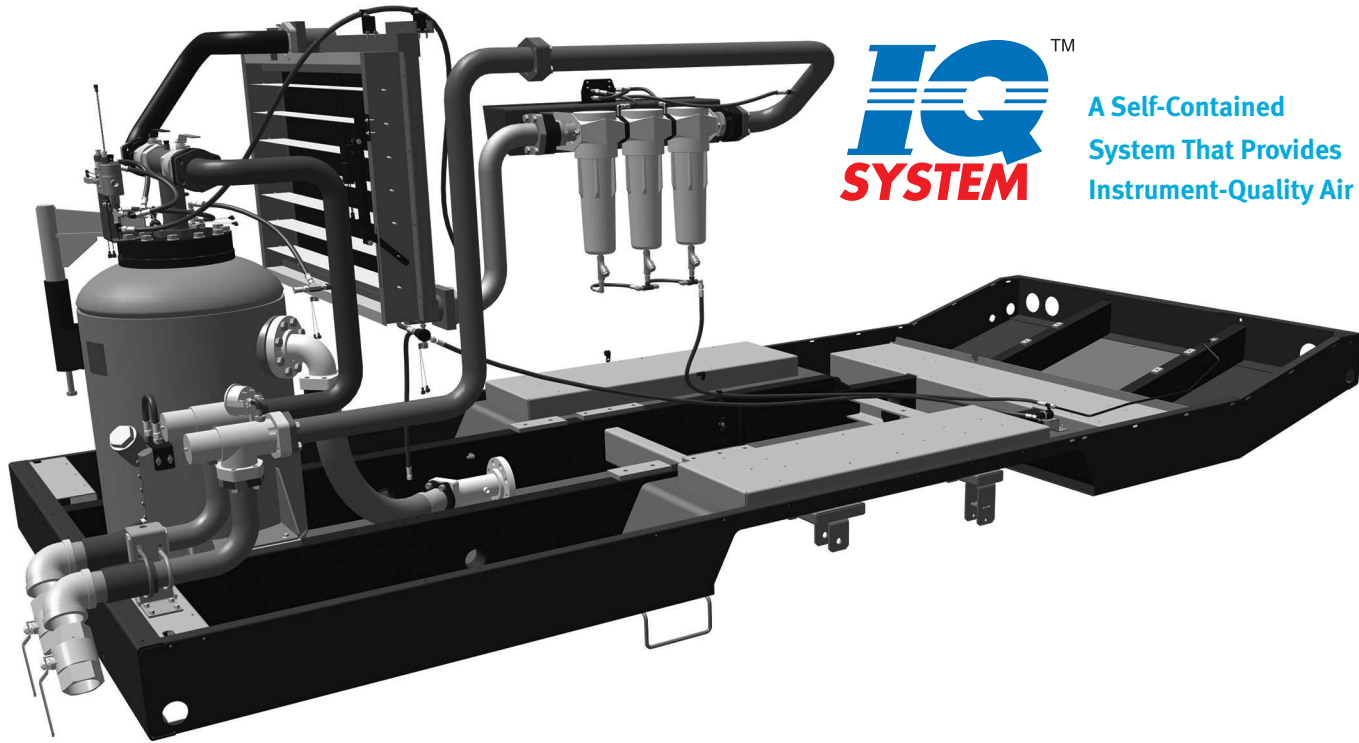

A Self-Contained
System That Provides
Instrument-Quality Air



Water Separator and IQ Filters

IQ System

Clean air is essential to the safety and efficiency of compressed air applications. From highly regulated jobsites to finished products such as steel structure painting, the need for clean, dry air continues to grow.

Doosan Portable Power IQ System air compressors provide instrument-quality air that is 99.99 percent free of contaminants — removing harmful dust, dirt, moisture and oil that are present in untreated air. The IQ system is equipped with a patented condensate removal process that vaporizes any moisture present

in ambient air to provide zero discharge and an internal aftercooler ensures compressed air is 20 degrees F above ambient air temperature.

A dual-filter system includes early warning indicators when filters require maintenance, while a pressure differential feature senses buildup in the filters and will safely shutdown the unit to ensure a consistent, reliable source of high-quality air. The result is clean, dry, cool, portable, compressed air.

The unique, onboard IQ system is fully-enclosed within the Doosan air compressor design. The all-in-one package provides the same portability customers expect from Doosan Portable Power equipment. The IQ system also delivers on versatility with the ability to select instrument-quality air or standard compressed air for applications that don't require pure, dry air. A lockable valve system makes it easy to instantly switch between the two options to tackle a variety of applications all in one day, saving time and money.

A photograph of a Doosan VP900e generator on a ship's deck. The generator is a large, white, rectangular unit with a prominent black grille on the right side. The brand name "DOOSAN" is printed in large, bold, black letters on the left side of the unit, and the model "VP900e" is printed in smaller black letters above it. A large, thick, white hose is connected to the generator and loops across the deck in the foreground. In the background, other ship equipment is visible, including a large white cylindrical tank and a metal structure with "4500 LB" written on it. The entire scene is bathed in a warm, orange light, suggesting a sunset or sunrise. The deck is made of dark wood planks.

DOOSAN

VP900^e

4500 LB

Specifications

Model	P185WDO-T4F	P250/HP185WDZ-T4F	
COMPRESSOR ROTARY SCREW/SINGLE-STAGE			
Free-Air Delivery – cfm (m ³ /min)	185 (5.2)	250 (7.0)	185 (5.2)
Rated Operating Pressure – psig (bar)	100 (6.9)	100 (6.9)	150 (10.3)
Pressure Range – psig (bar)	80 – 125 (5.5 – 8.6)	80 – 175 (5.5 – 12.1)	
Air Discharge Outlet Size – in (mm)	0.75 (19)		0.75 (19)
Air Discharge Outlet Quantity	2		2
Fuel Tank Capacity – gal (L)	27 (102)		27 (102)
ENGINE			
Make/Model	Doosan D24	Deutz TD2.9	
Emissions Tier Level	Tier 4 Final (T4F)	Tier 4 Final (T4F)	
Number of Cylinders	4		4
Displacement – cu in (L)	147 (2.4)		177 (2.9)
Rated Speed – rpm	2600	2400	1900
Idle Speed – rpm	1700		1700
Bhp @ Rated Speed (kW)	49 (36.4)	74 (55.2)	
Electrical - volts	12		12
Hours of Operation @ Full Load	10	7.2	7.8
DIMENSIONS WITH RUNNING GEAR			
Length – in (mm)	137.6 (3494)	142.5 (3620)	
Width – in (mm)	68.5 (1740)	68.5 (1740)	
Height – in (mm)	66 (1676)	67 (1701)	
Track Width – in (mm)	59 (1499)	59 (1499)	
Tire Size – in	15		15
Shipping Weight – w/o fuel – lb (kg)	2260 (1025)	2610 (1184)	
Working Weight – w fuel – lb (kg)	2447 (1110)	2813 (1276)	
DIMENSIONS WITHOUT RUNNING GEAR			
Length – in (mm)	88 (2235)	93.5 (2375)	
Width – in (mm)	49.3 (1252)	49.3 (1252)	
Height – in (mm)	58 (1473)	55.4 (1406)	
Shipping Weight – w/o fuel – lb (kg)	2035 (923)	2386 (1082)	
Working Weight – w fuel – lb (kg)	2222 (1008)	2589 (1174)	

Model	P185WDOU	XP185WDOUA
COMPRESSOR		
Free-Air Delivery – cfm (m ³ /min)	185 (5.2)	185 (5.2)
Rated Operating Pressure – psi (bar)	100 (6.9)	125 (8.6)
Pressure Range – psi (bar)	80 – 125 (5.5 – 8.6)	80-150 (5.5 - 10.3)
Air Discharge Outlet NPT Size – in (mm)	0.75 (19.0)	0.75 (19.0)
Air Discharge Outlet Quantity	2	2
ENGINE		
Make/Model	Doosan D24	Doosan D24
Emissions Tier Level	Tier 4 Final	Tier 4 Final
Number of Cylinders	4	
Displacement – cu in (L)	147 (2.4)	147 (2.4)
Rated Speed – rpm	2600	
Idle Speed – rpm	1700	
Bhp @ Rated Speed (kW)	49 (36.4)	72.3 (53.9)
Electrical - volts	12	
Engine Oil Capacity – gal (L)	2.5 (9.5)	2.5 (9.5)
Radiator Coolant Capacity – gal (L)	3 (11.4)	3 (11.4)
Fuel Tank Capacity – gal (L)	27 (102)	
DIMENSIONS		
Length including Y valves – in (mm)	84 (2133)	84 (2133)
Width – in (mm)	33.3 (846)	
Height – in (mm)	52.5 (1334.59)	52.5 (1334.59)
Shipping Weight w/o fuel – lb (kg)	2034 (922)	2034 (922)
Working Weight w/ fuel – lb (kg)	2300 (1043.3)	2300 (1043.3)

Specifications

Model	C185WDZ-T4F	C185WKUBG
COMPRESSOR ROTARY SCREW/SINGLE-STAGE		
Free-Air Delivery – cfm (m3/min)	185 (5.2)	185 (5.2)
Rated Operating Pressure – psig (bar)	100 (6.9)	100(6.9)
Pressure Range – psig (bar)	80 – 125 (5.5 – 8.6)	80 – 125 (5.5 – 8.6)
Air Discharge Outlet Size – in (mm)	0.75 (19)	0.75 (19)
Air Discharge Outlet Quantity	2	2
Fuel Tank Capacity – gal (L)	21 (79)	24 (89)
ENGINE		
Make/Model	Deutz	Kubota WG2503-G-E3
Emissions Tier Level	Tier 4 Final (T4F)	Meets EPA Reg
Number of Cylinders	4	4
Displacement – cu in (L)	177 (2.9)	153 (2.5)
Rated Speed – rpm	2600	2600
Idle Speed – rpm	1700	1700
Bhp @ Rated Speed (kW)	49 (36.6)	49.9 (37.2)
Electrical - volts	12	12
Hours of Operation @ Full Load	7	6
DIMENSIONS WITH RUNNING GEAR		
Length – in (mm)	133.7 (3396)	133.7 (3396)
Width – in (mm)	61.7 (1567)	61.7 (1567)
Height – in (mm)	63 (1600)	63 (1600)
Track Width – in (mm)	54 (1372)	54 (1372)
Tire Size – in	13	13
Shipping Weight – w/o fuel – lb (kg)	2065 (937)	1905 (864)
Working Weight – w fuel – lb (kg)	2215 (1005)	2037 (924)
DIMENSIONS WITHOUT RUNNING GEAR		
Length – in (mm)	77.6 (1971)	77.6 (1971)
Width – in (mm)	51.3 (1303)	51.3 (1303)
Height – in (mm)	52.7 (1339)	52.7 (1339)
Shipping Weight – w/o fuel – lb (kg)	1828 (829)	1706 (774)
Working Weight – w fuel – lb (kg)	1977 (897)	1837 (833)

Model	P425/HP375		HP450/VHP400	
COMPRESSOR ROTARY SCREW/SINGLE-STAGE				
	LOW PRESSURE	HIGH PRESSURE	LOW PRESSURE	HIGH PRESSURE
Free-Air Delivery – cfm (m3/min)	425 (12.0)	375 (10.6)	450 (12.7)	400 (11.3)
Rated Operating Pressure – psig (bar)	100 (6.9)	150 (10.3)	150 (10.3)	200 (13.8)
Pressure Range – psig (bar)	80 - 175 (5.5 - 12.1)		80 - 225 (5.5 - 15.5)	
Air Discharge Outlet Size – in (mm)	1.25 (31.8)		1.25 (31.75)	
Air Discharge Outlet Quantity	1		1	
Fuel Tank Capacity – gal (L)	60 (227)		60 (227)	
ENGINE				
Make/Model	Cummins/QSB4.5		Cummins/QSB4.5	
Emissions Tier Level	Tier 4 Final (T4F)		Tier 4 Final (T4F)	
Number of Cylinders	4		4	
Displacement – cu in (L)	272 (4.5)		272 (4.5)	
Rated Speed – rpm	2200	1950	2350	2100
Idle Speed – rpm	1500		1500	
Bhp @ Rated Speed (kW)	130 (97)	138 (102.9)	168 (125.3)	163 (121.6)
Electrical - volts	24		24	
Hours of Operation @ Full Load	10.9	10.6	8.5	8.3
DIMENSIONS WITH RUNNING GEAR				
Length – in (mm)	152.5 (3874)		152.5 (3874)	
Width – in (mm)	78.2 (1986)		78.2 (1986)	
Height – in (mm)	69.9 (1775)		69.9 (1775)	
Track Width – in (mm)	66.6 (1692)		66.6 (1692)	
Tire Size – in	15		15	
Shipping Weight – w/o fuel – lb (kg)	4470 (2027)		4470 (2027)	
Working Weight – w fuel – lb (kg)	5030 (2281)		5030 (2281)	
DIMENSIONS WITHOUT RUNNING GEAR				
Length – in (mm)	104.2 (2647)		104.2 (2647)	
Width – in (mm)	60.7 (1542)		60.7 (1542)	
Height – in (mm)	61 (1549)		61 (1549)	
Shipping Weight – w/o fuel – lb (kg)	4207 (1908)		4207 (1908)	
Working Weight – w fuel – lb (kg)	4767 (2162)		4767 (2162)	

Model	XP825/HP750	HP1600
COMPRESSOR ROTARY SCREW/SINGLE-STAGE		
	LOW PRESSURE	HIGH PRESSURE
Free-Air Delivery – cfm (m3/min)	825 (23.4)	750 (21.2)
Rated Operating Pressure – psig (bar)	125 (8.6)	150 (10.3)
Pressure Range – psig (bar)	80-175 (5.5-12.1)	80 - 150 (5.5 - 10.3)
Air Discharge Outlet Size – in (mm)	2-inch NPT (50.8)	3 NPT (76.2)
Air Discharge Outlet Quantity	1	1 (2 with IQ)
Fuel Tank Capacity – gal (L)	100 (379)	222.4 (841.9)
ENGINE		
Make/Model	Cummins/QSB6.7	Cummins/QSX15
Emissions Tier Level	Tier 4 Final (T4F)	Tier 4 Final (T4F)
Number of Cylinders	6	6
Displacement – cu in (L)	408 (6.7)	912 (14.9)
Rated Speed – rpm	2100 / 1935	1800
Idle Speed – rpm	1300	1200
Bhp @ Rated Speed (kW)	266 (198) / 262 (195)	580 (433)
Electrical - volts	24	24
Hours of Operation @ Full Load	9.1 / 9.3	8.13
DIMENSIONS WITH RUNNING GEAR		
Length – in (mm)	203 (5164)	292.4 (7427)
Width – in (mm)	90.2 (2291)	90.1 (2290)
Height – in (mm)	88.5 (2248)	99.5 (2527)
Track Width – in (mm)	80.3 (2040)	71 (1803)
Tire Size – in	15	17.5
Shipping Weight – w/o fuel – lb (kg)	8620 (3910)	17874 (8106)
Working Weight – w fuel – lb (kg)	9330 (4230)	19565 (8873)
DIMENSIONS WITHOUT RUNNING GEAR		
Length – in (mm)	152.4 (3871)	228.2 (5796)
Width – in (mm)	80.6 (2047)	90.1 (2290)
Height – in (mm)	79 (2007)	98.2 (2494)
Shipping Weight – w/o fuel – lb (kg)	7840 (3560)	16899 (7664)
Working Weight – w fuel – lb (kg)	8550 (3880)	18590 (8431)

Model	HP915	XP1000
COMPRESSOR ROTARY SCREW/SINGLE-STAGE		
Free-Air Delivery – cfm (m3/min)	915 (25.9)	1000 (28.3)
Rated Operating Pressure – psig (bar)	150 (10.3)	125 (8.6)
Pressure Range – psig (bar)	80 - 175 (5.5 - 12.1)	80 - 150 (5.5 - 10.3)
Air Discharge Outlet Size – in (mm)	2-inch NPT (50.8)	2-inch NPT (50.8)
Air Discharge Outlet Quantity	1	1
Fuel Tank Capacity – gal (L)	128 (485)	128 (485)
ENGINE		
Make/Model	Cummins/QSL9	Cummins/QSL9
Emissions Tier Level	Tier 4 Final (T4F)	Tier 4 Final (T4F)
Number of Cylinders	6	6
Displacement – cu in (L)	543 (8.9)	543 (8.9)
Rated Speed – rpm	1800	1800
Idle Speed – rpm	1200	1200
Bhp @ Rated Speed (kW)	303 (226)	303 (226)
Electrical - volts	24	24
Hours of Operation @ Full Load	8.7	8.7
DIMENSIONS WITH RUNNING GEAR		
Length – in (mm)	226.6 (5748)	226.6 (5748)
Width – in (mm)	82.6 (2098)	82.6 (2098)
Height – in (mm)	101.3 (2573)	101.3 (2573)
Track Width – in (mm)	69.3 (1760)	69.3 (1760)
Tire Size – in	16	16
Shipping Weight – w/o fuel – lb (kg)	10461 (4745)	10461 (4745)
Working Weight – w fuel – lb (kg)	11309 (5130)	11309 (5130)
DIMENSIONS WITHOUT RUNNING GEAR		
Length – in (mm)	171 (4343)	171 (4343)
Width – in (mm)	83 (2108)	83 (2108)
Height – in (mm)	95 (2413)	95 (2413)
Shipping Weight – w/o fuel – lb (kg)	9740 (4418)	9740 (4418)
Working Weight – w fuel – lb (kg)	10765 (4883)	10765 (4883)

Model	VP900e		
COMPRESSOR	LOW PRESSURE	MEDIUM PRESSURE	HIGH PRESSURE
Free-Air Delivery – cfm (m³/min)	900 (25.5)	825 (23.4)	750 (21.2)
Rated Operating Pressure – psi (bar)	100 (6.9)	125 (8.6)	150 (10.3)
Pressure Range – psi (bar)	80 - 175 (5.5 - 10.3)		
Air Discharge Outlet NPT Size – in (mm)	2-inch NPT (50.8)		
Operation Temperature Range (F)	-20 to 120		
MOTOR-ELECTRIC			
Motor Power hp (kW)	225 (168)		
System Voltage	480		
Hz	60		
Motor-Phase	3		
MOTOR CONTROL SYSTEM			
Drive Type	Variable Frequency		
DIMENSIONS WITH RUNNING GEAR			
Overall Length – in (mm)	194 (4928)		
Overall Width – in (mm)	87 (2210)		
Overall Height – in (mm) excluding exh pipe	85 (2159)		
Shipping Weight lb (kg)	9530 (4322)		
DIMENSIONS WITHOUT RUNNING GEAR			
Overall Length – in (mm)	141.5 (3594)		
Overall Width – in (mm)	87 (2210)		
Overall Height – in (mm)	76 (1930)		
Shipping Weight lb (kg)	8730 (3960)		

Model	XHP750WCU T4F	XHP1000WCAT	XHP1170WCU
COMPRESSOR			
Free-Air Delivery – cfm (m³/min)	750 (21.2)	1000 (28.3)	1170 (33.1)
Rated Operating Pressure – psi (bar)	350 (24.1)	365 (25.1)	365 (25.1)
Pressure Range – psi (bar)	140-365 (9.7-24.1)	140-365 (9.7-25.2)	140-365 (9.7-25.2)
Air Discharge Outlet NPT Size – in (mm)	2 (50.8)	3 (76.2)	3 (76.2)
Air Discharge Outlet Quantity	1	1	1 (2 with IQ)
Compressor Oil Capacity – gal (L)	26.7 (101)	47 (178)	55 (208)
ENGINE			
Engine Make/Model	Cummins/QSL9	Caterpillar C13	Cummins/QSX15
Emissions Tier Level	Tier 4 Final (T4F)	Tier 4i	Tier 4 Final (T4F)
# of Cylinders	6	6	6
Displacement – cu in (L)	543 (8.9)	763 (12.5)	912 (14.9)
Rated Speed – rpm	1800	1800	1800
Idle Speed – rpm	1350	1350	1200
Bhp @ Rated Speed (kW)	340 (254)	475 (354)	580 (433)
Electrical – volts	24	24	24
Engine Oil Capacity – qt (L)	23.2 (22)	40 (37.9)	48 (45)
Radiator Coolant Capacity – gal (L)	15.3 (58)	17 (64.4)	26 (98)
Altitude Capability – ft (m)	9000 (2743)	10000 (3048)	9800 (2987)
Fuel Consumption @ 100% load – gph (L/h)	46.1 (60.2)	20.4 (77.2)	23.5 (89)
Fuel Tank Capacity – gal (L)	128.1 (485)	180 (681)	222.4 (841.9)
DEF Tank Capacity - gal (L)	10 (38)	N/A	15.6 (59)
DIMENSIONS WITH RUNNING GEAR			
Overall Length – in (mm)	226.3 (5748)	202.75 (5150)	292.4 (7427)
Overall Width – in (mm)	82.6 (2099)	83.6 (2123)	90.1 (2289)
Overall Height – in (mm) excluding exh pipe	101.3 (2573)	100.5 (2552.7)	99.5 (2527)
Track Width – in (mm)	69.3 (1760)	78.5 (1994)	71 (1803)
Tire Size – in	16	17.5	17.5
Shipping Weight w/o fuel – lb (kg)	11067 (5020)	15177 (6884)	17355 (7871)
Working Weight w/ fuel – lb (kg)	12213 (5540)	17021 (7721)	18835 (8542)
DIMENSIONS WITHOUT RUNNING GEAR			
Overall Length – in (mm)	171 (4343)	193.5 (4915)	228.2 (5796)
Overall Width – in (mm)	83 (2109)	83.6 (2123)	90.1 (2289)
Overall Height – in (mm) w/ shockmounts	95 (2413)	84.9 (2156)	98.2 (2494)
Shipping Weight w/o fuel – lb (kg)	10346 (4693)	14230 (6455)	16169 (7333)
Working Weight w/ fuel – lb (kg)	11669 (5293)	16074 (7291)	17860 (8100)

DOOSAN

DOOSAN

HP375

DOOSAN

DOOSAN

IQTM
SYSTEM

5
DOOSAN

DOOSAN

Experience Doosan Portable Power and our industry-leading support and service. Whatever the job, we have the solution. From our comprehensive range of reliable air compressors, to lighting systems and generators, we have a solution to fit your needs. Running a successful business takes more than powerful equipment. That's why Doosan Portable Power partners with an experienced dealer network to stand beside you every step of the way. Doosan Portable Power — more than 100 years of providing excellence.



Doosan Portable Power
1293 Glenway Drive
Statesville, NC 28625
DoosanPortablePower.com

©2017 Doosan Infracore Portable Power

Warranty

Standard Warranty:

1 year / 2,000 hours total machine
Engines: Doosan - 3 year / 3,000 hours
Others: 2 year / 4,000 hours
Airend: 2 year / 4,000 hours

Optional Extended Warranty:

Must enroll to be eligible. 5 year / 10,000 hours major component warranty. Covers major engine components, airend, and coupling, if the machine is serviced at prescribed intervals using Doosan fluids and filters. See specific Warranty Brochure for specific coverage and limitations.



Product improvement is a continuous goal at Doosan Infracore Portable Power. Specifications and design are subject to change without notice or obligation. Warranty terms and conditions on new product sales are subject to change. All products are subject to the terms of the applicable warranty in effect on the date of purchase; contact your local Doosan dealer for the current applicable warranty. DOOSAN and the Doosan logo are trademarks of Doosan Corporation.

Courtesy of Machine.Market