

Series 2

# DLT2-60

FEATURING A 22" BASKET ELEVATOR AND TOP MOUNTED JIB AND WINCH

# DUR-A-LIFT®

CATEGORIES  
C, D, & E  
NOW AVAILABLE  
TO MEET NEW  
ANSI A92.2  
STANDARDS



180°  
BASKET  
ROTATION

Options available for  
double person baskets  
in the DU and DP series

Experience working heights up to

# 67 FEET

AND SIDE REACH TO 39' 2"



## TOP MOUNTED JIB & WINCH

Allows the operator to rotate the jib to  
work on either side of the rotating basket.



## 22" BASKET ELEVATOR

The hydraulically activated basket elevator  
allows the operator to raise the basket 22"  
without repositioning the booms or the jib.



[sales@dur-a-lift.com](mailto:sales@dur-a-lift.com)  
[www.dur-a-lift.com](http://www.dur-a-lift.com)

Dur-A-Lift Inc., P.O. Box 31, George, Iowa 51237  
(877) 4-DURALIFT (877) 438-7254 | Fax: (712) 475-2809

# DLT2-60

TELESCOPIC ARTICULATING PERSONNEL OR MATERIAL HANDLING AERIAL LIFT

## SPECIFICATIONS

DLT2-60

Height to bottom of platform*	62'
Working height*	67'
Side reach	39' 2"
Stowed travel height	12'
Platform capacity (MH MODEL)	400#
Platform capacity using jib (DU MODEL)	400#
Platform capacity not using jib (DU MODEL)	550#
Platform capacity (DP MODEL)	600#
Approximate weight	5700#
Articulating arm travel	0 to 75
Main boom travel	-30 to 75
Extension Travel	148"

Minimum GVWR will change significantly depending on make of chassis and stabilizer option. Dur-A-Lift Inc. reserves the right to improve models and change specifications without notice or obligation. Dur-A-Lift equipment meets or exceeds all applicable ANSI Standards as of the date of manufacture.

\*Maximum height achievable with addition of the optional 22" basket elevator.



## STANDARD

- Proportional controls
- Lower override controls
- Engine start/stop from basket
- **Basket access from ground**
- Compensated upper boom
- Insulated models available in category C, D and E
- Hydraulic basket leveling
- **Continuous rotation**
- Joystick and lockout controls
- **180° basket rotator**

## MH FEATURES

MATERIAL HANDLING

- **Up to 1000# top mounted jib and winch**
- Upper and lower winch control
- 400# basket capacity
- 24"x30" fiberglass basket

## DP FEATURES

DUAL PERSON

- 600# basket capacity
- 24"x42" fiberglass basket

## DU FEATURES

DUAL CONFIGURATION:  
DUAL PERSON OR MATERIAL HANDLING

- **Up to 1000# top mounted jib and winch**
- 550# basket capacity when not using winch
- 400# basket capacity when using winch
- 24"x42" fiberglass basket

## OPTIONS

- High electrical resistant controls **STANDARD ON CAT. C**
- Outriggers
- Basket liner for fiberglass baskets
- Fiberglass main and articulating booms
- Tool circuits
- D.C. backup system
- **22" basket elevator**
- **Aluminum basket**
- **Non-insulated version available DPM2S**
- 110 v outlet at basket **DPM2S**

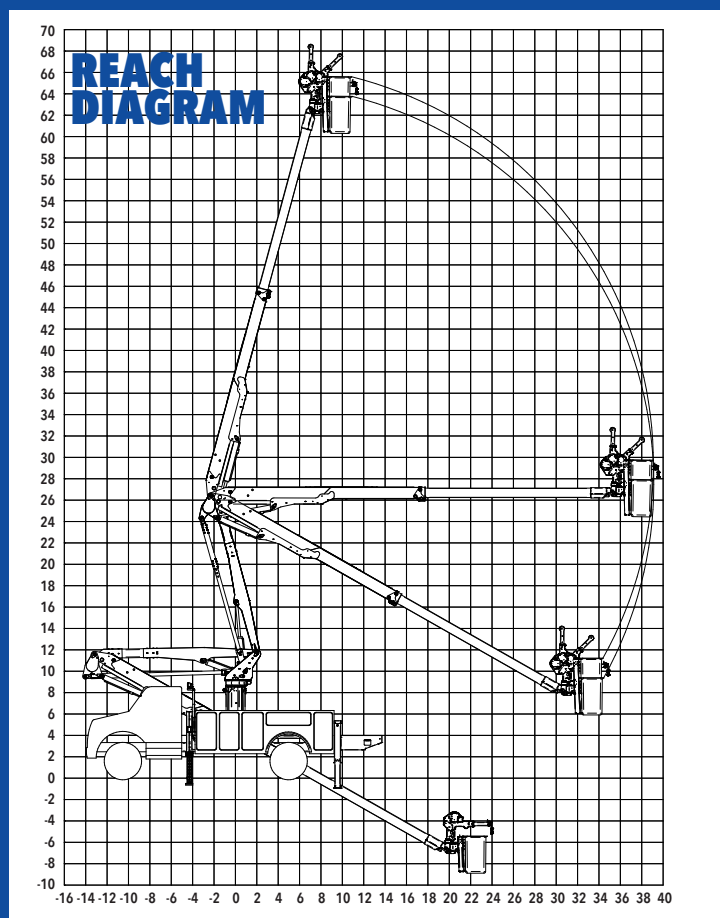

This aerial lift is sold and serviced by:



sales@dur-a-lift.com  
www.dur-a-lift.com

Dur-A-Lift Inc., P.O. Box 31, George, Iowa 51237  
(877) 4-DURALIFT (877) 438-7254 | Fax: (712) 475-2809