

DPM-36 & DPM-40

TELESCOPIC ARTICULATING PERSONNEL OR MATERIAL HANDLING AERIAL LIFT

DUR-A-LIFT®

CATEGORIES
C, D, & E
NOW AVAILABLE
TO MEET NEW
ANSI A92.2
STANDARDS

Working heights up to
45 FEET
AND SIDE REACH UP TO 33'6"



180°
BASKET
ROTATION

Options available for
double person baskets
in the DU and DP series



- Convenient access to all the compartments right from the basket.
- -35° boom angle allows for access to the basket from ground level.
- Conveniently positioned controls will allow the operator to be more effective when maneuvering their materials.



sales@dur-a-lift.com
www.dur-a-lift.com

Dur-A-Lift Inc., P.O. Box 31, George, Iowa 51237
(877) 4-DURALIFT (877) 438-7254 | Fax: (712) 475-2809

DPM-36 & DPM-40

TELESCOPIC ARTICULATING PERSONNEL OR MATERIAL HANDLING AERIAL LIFT

SPECIFICATIONS

	DPM-36	DPM-40
Height to bottom of platform	36'	40'
Working height	41'	45'
Side reach (MH, DU AND DP MODELS)	27' 6"	31' 6"
Side reach (SP MODEL)	29' 6"	33' 6"
Stowed travel height	10' 6"	10' 6"
Platform capacity (MH AND SP MODELS)	400#	400#
Platform capacity using jib (DU MODEL)	400#	400#
Platform capacity not using jib (DU MODEL)	550#	550#
Platform capacity (DP MODEL)	600#	600#
Approximate weight	3700#	3900#
Articulating arm travel (MH, DU AND DP)	0 to 80	0 to 80
Articulating arm travel (SP MODEL)	0 to 96	0 to 96
Main boom travel	-35 to 80	-35 to 80
Extension Travel	96"	120"

Minimum GVWR will change significantly depending on make of chassis and stabilizer option. Dur-A-Lift Inc. reserves the right to improve models and change specifications without notice or obligation. Dur-A-Lift equipment meets or exceeds all applicable ANSI Standards as of the date of manufacture.

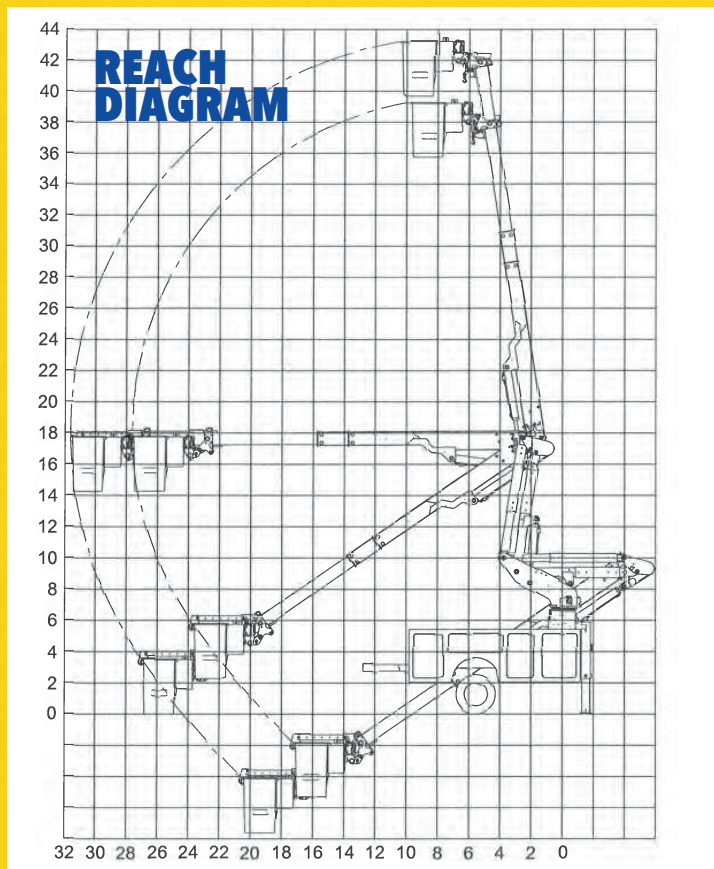

STANDARD

- Proportional controls
- Lower override controls
- Engine start/stop from basket
- **Basket access from ground**
- Compensated upper boom
- Insulated models available in category C, D and E
- **Hydraulic basket leveling**
- **Continuous rotation**
- Joystick and lockout controls

OPTIONS

- High electrical resistant controls
- Outriggers
- Basket liner for fiberglass baskets
- Fiberglass main and articulating booms
- Tool circuits
- D.C. backup system
- 180° basket rotator **DU**
- **Aluminum basket**
- **Non-insulated version available** **DPMS**



DP MODEL



MH MODEL

MH FEATURES

MATERIAL HANDLING

- Up to 1000# side mounted jib and winch
- Upper and lower winch control
- 400# basket capacity
- 24" X 30" fiberglass basket
- 180° basket rotator

SP FEATURES

SINGLE PERSON

- 400# basket capacity
- 24" X 30" fiberglass basket
- 180° basket rotator
- 33' 6" side reach

DP FEATURES

DUAL PERSON

- 600# basket capacity
- 24" X 48" fiberglass basket
- 180° basket rotator

DU FEATURES

DUAL CONFIGURATION:
DUAL PERSON OR MATERIAL HANDLING

- Up to 1000# side mounted jib and winch
- 550# basket capacity when not using winch
- 400# basket capacity when using winch
- 24" X 42" fiberglass basket
- 100° basket rotator

This aerial lift is sold and serviced by:



sales@dur-a-lift.com
www.dur-a-lift.com

Dur-A-Lift Inc., P.O. Box 31, George, Iowa 51237
(877) 4-DURALIFT (877) 438-7254 | Fax: (712) 475-2809

DPM-47 & DPM-52

TELESCOPIC ARTICULATING AERIAL LIFT

DUR-A-LIFT®

CATEGORIES
C, D, & E
NOW AVAILABLE
TO MEET NEW
ANSI A92.2
STANDARDS

Working heights up to
57 FEET
AND SIDE REACH UP TO 31'6"



180°
BASKET
ROTATION

Options available for
double person baskets
in the DU and DP series



- Convenient access to all the compartments right from the basket.
- -35° boom angle allows for access to the basket from ground level.
- Conveniently positioned controls will allow the operator to be more effective when maneuvering their materials.



sales@dur-a-lift.com
www.dur-a-lift.com

Dur-A-Lift Inc., P.O. Box 31, George, Iowa 51237
(877) 4-DURALIFT (877) 438-7254 | Fax: (712) 475-2809

DPM-47 & DPM-52

SPECIFICATIONS

	DPM-47	DPM-52
Height to bottom of platform	47'	52'
Working height	52'	57'
Side reach	31'6"	31'6"
Stowed travel height	10'5"	11'8"
Platform capacity (MH MODELS)	400#	400#
Platform capacity using jib (DU MODEL)	400#	400#
Platform capacity not using jib (DU MODEL)	550#	550#
Platform capacity (DP MODELS)	600#	600#
Approximate weight	4300#	4400#
Articulating arm travel	0 to 80	0 to 80
Main boom travel	-35 to 80	-35 to 80
Extension travel	120"	120"

Minimum GVWR will change significantly depending on make of chassis and stabilizer option. Dur-A-Lift Inc. reserves the right to improve models and change specifications without notice or obligation. Dur-A-Lift equipment meets or exceeds all applicable ANSI Standards as of the date of manufacture.

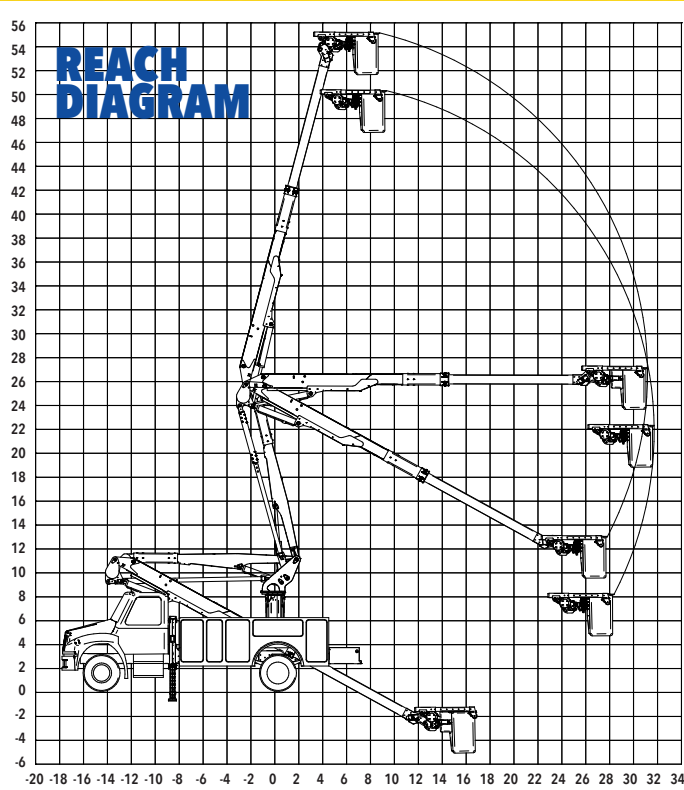

This aerial lift is sold and serviced by:

STANDARD

- Proportional controls
- Lower override controls
- Engine start/stop from basket
- **Basket access from ground**
- Compensated upper boom
- Insulated cat "C" extension boom
- Hydraulic basket leveling
- Continuous rotation
- Joystick and lockout controls

MH FEATURES

MATERIAL HANDLING

- Up to 1000# jib and winch
- **Upper and lower winch control**
- 400# basket capacity
- 24" X 30" fiberglass basket
- **180° basket rotator**

DP FEATURES

DUAL PERSON

- 600# basket capacity
- 24" X 48" fiberglass
- **180° basket rotator**

DU FEATURES

DUAL CONFIGURATION:
DUAL PERSON OR MATERIAL HANDLING

- Up to 1000# jib and winch
- 550# basket capacity when not using winch
- 400# basket capacity when using winch
- 24" X 42" fiberglass basket
- 24" X 42" aluminum basket
- 100° basket rotator



Double person baskets available in our DU and DP models.

OPTIONS

- High electrical resistant controls
- Outriggers
- Basket liner for fiberglass baskets
- Tool circuits
- Fiberglass main and articulating booms
- D.C. backup system
- 180° basket rotator **DU**
- Aluminum basket



sales@dur-a-lift.com
www.dur-a-lift.com

Dur-A-Lift Inc., P.O. Box 31, George, Iowa 51237
(877) 4-DURALIFT (877) 438-7254 | Fax: (712) 475-2809