

Dynapac CP2700

Pneumatic rollers

Atlas Copco





Technical data

 Masses	
Operating mass (incl. ROPS)	12,400 kg
Mass with max. ballast	27,000 kg
Mass with wet sand ballast	20,500 kg

 Traction	
Speed low	7 km/h
Speed high	20 km/h

 Compaction	
Rolling width	2,300 mm
Tyre overlap	42 mm
Wheel loads, without ballast	1,200 kg
Wheel loads, with wet sand ballast	1,900 kg
Wheel loads, with max. ballast	3,000 kg
Tyre pressure, min	250 kPa
Tyre pressure, max	850 kPa
Tyre type (smooth)	13/80 R20
Water spray system, type	Pressurized
Water spray system, tank capacity	415 l
Water spray system, spray nozzle	one per tyre
Ballast volume	3 m ³

 Engine	
Manufacturer/Model	Cummins QSB 4.5 (Tier 3)
Rated power, SAE J1995	85 kW (110 hp) @ 2,200 rpm
Type	Water cooled turbo Diesel
Fuel tank capacity	210 l
Electrical system	24V

 Engine	
Manufacturer/Model	Cummins QSB 3.8 (Tier 4F)
Rated power, SAE J1995	89 kW (118 hp) @ 2,200 rpm

 Engine	
Manufacturer/Model	Cummins QSB 4.5 (Tier 3)
Rated power, SAE J1995	93 kW (124 hp) @ 2,200 rpm

 Engine	
Manufacturer/Model	Cummins QSB 3.8 (Tier 4F)
Rated power, SAE J1995	97 kW (130 hp) @ 2,200 rpm

 Hydraulic system	
Driving	Axial piston pump with variable displacement. Axial piston motors (2) with variable displacement.
Steering	Axial piston pump with variable displacement.
Service brake	2 multidisc brakes on rear wheels activated by pedal.
Parking/ Emergency brake	Failsafe multidisc brakes in both gear boxes.

Find us locally at www.atlascopco.com

We reserve the right to change specifications without notice. Photos and illustrations do not always show standard versions of machines. The above information is a general description only, all informations are supplied without liability.

rce_cp2700_en-20160613.131724.pdf 2016-06-13 13:17

Dynapac CP2700

Pneumatic rollers

Atlas Copco

Technical data

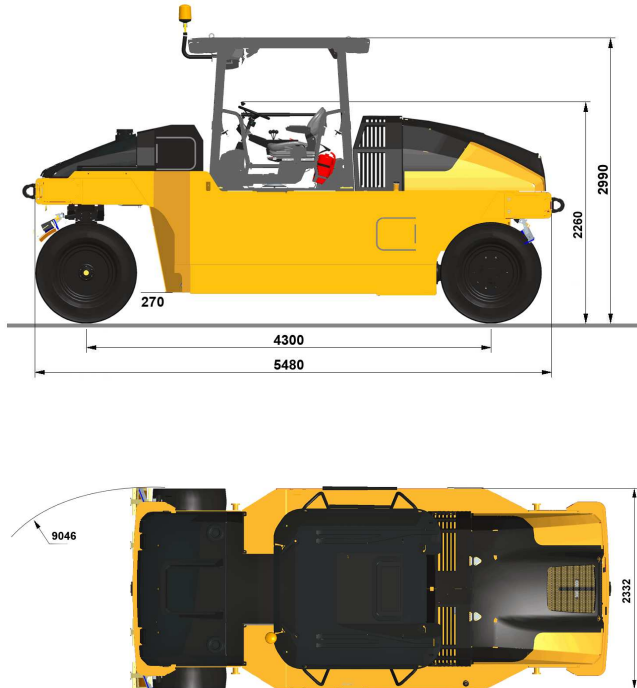

Service and repair kits

Type of kit	P/N	Serial Number/Additional info
50h service kit	4812155998	CP2700 Teir 3 s/n 10000502x0B003898-
250h service kit	4812101896	CP2700 Teir 3 s/n 10000502x0B003898-
500h service kit	4700945806, 4812101897	CP2700 Teir 3 s/n 10000502x0B003898-
750h service kit	4812101896	CP2700 Teir 3 s/n 10000502x0B003898-
1000h service kit	4812155999, 4812101916	CP2700 Teir 3 s/n 10000502x0B003898-
50h service kit	4812316684	CP2700 Teir 4i s/n 10000507x0B003949-
250h service kit	4812316685, 4812316686	CP2700 Teir 4i s/n 10000507x0B003949-
500h service kit	4812316687, 4812316688	CP2700 Teir 4i s/n 10000507x0B003949-
750h service kit	4812316685, 4812316686	CP2700 Teir 4i s/n 10000507x0B003949-
1000h service kit	4812316689, 4812316690	CP2700 Teir 4i s/n 10000507x0B003949-
Sprinkler kit	4812155698	
Scraper kit	4812155696	
Air on the run kit	4812155751	Front
Air on the run kit	4812155751	Rear
Working lights kit	470PP81096	

Find us locally at www.atlascopco.com

We reserve the right to change specifications without notice. Photos and illustrations do not always show standard versions of machines. The above information is a general description only, all informations are supplied without liability.

rce_cp2700_en-20160613.131724.pdf 2016-06-13 13:17