



Technical Specification MS50

EDGE® reserve the right to alter any details contained without notice. COPYRIGHT© 2011



GENERAL TECHNICAL DATA

OPERATION MODE

- Extended Machine Width..... 3489mm / 11 ft 4 ins
- Length. 15586mm / 51ft 2ins
- Maximum Discharge Height: 8056mm / 26ft 5ins
- Minimum Discharge Height:..... 4224mm / 13ft 10 ins
- Working Angle: 12-30 degrees

TRANSPORT MODE

- Transport Width..... 2450mm / 8ft
- Transport Length 12623mm / 41ft 5ins
- Transport Height Machine Folded: 3711mm / 12ft 1ins
- Transport Height Machine Un-Folded: 3935mm / 12ft 9ins

WEIGHTS

- Hydraulic Drive Machine3040KG (3.3 US Ton)
- Electric Drive Machine2640KG (2.9 US Ton)

MS50 Page 1/6

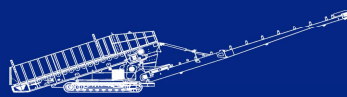

EDGE ARE GLOBAL LEADERS IN THE DESIGN INDUSTRY - MATERIALS RECYCLING - AGGREGATE PROCESSING - MINERALS HANDLING



EDGE® Design & Engineering Innovation

30 Farlough Road, Newmills, Dungannon, Co. Tyrone, BT71 4DT.

E-mail: info@edgeinnovate.com Web: www.edgeinnovate.com

Tel: +44 28 8774 0525 Fax: +44 28 8774 7244

MAIN CONVEYOR

- Belt Width:800mm / 32ins
- Belt Type:EP 400 3 ply belt
- Drum Centres:14.3 metres
- Drive drum:298mm
- Tail drum:220mm

HYDRAULICS

- Hydraulic Motor..... Danfoss OMT500

CHASSIS

- Tyres.....11.5/80 x 15.3 RIM & TYRE 6 STUD

ALL-ELECTRIC

- 3 phase.....380 - 415 Volts

ELECTRIC MOTOR

- Type:7.5kw
- Motor rpm:1400 rpm
- Gearbox Torque:1570nm,
- Ratio:7.5kw at 20.23/1 which produces 1022nm
- Output rpm:71

STANDARD MACHINE INCLUDES:

- 30ft Coupling Hose Kit
- Tow Bar and Ground Pivot Stand c/w wheels
- Danfoss Motor
- Hydraulic Angle Adjustment (only on hydraulic machines)
- 2.5" Self Lube Triple Seal Bearings
- Varied angle wing rollers

OPTIONS

- Belt: (Chevron / Heavy Duty)
- Anti-Roll Back Flaps
- Power Source: (Diesel Hydraulic / Electric)
- Scraper Upgrade
- Enclosed Skirting
- Feedboot Extension

MS50 Page 2/6

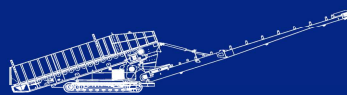

EDGE ARE GLOBAL LEADERS IN THE DESIGN INDUSTRY - MATERIALS RECYCLING - AGGREGATE PROCESSING - MINERALS HANDLING



EDGE[®] Design & Engineering Innovation
30 Farlough Road, Newmills, Dungannon, Co. Tyrone, BT71 4DT.
E-mail: info@edgeinnovate.com Web: www.edgeinnovate.com
Tel: +44 28 8774 0525 Fax: +44 28 8774 7244

ADVANTAGES:

- 4No. easily fitted in & out of a 40ft container minimising transport costs
- Can be used for a variety of applications including: Crushed aggregate, top soil, bark, coal, sand & fines
- Low cost radial stacking solution
- Reduced operating fuel costs
- Greater operating efficiency; less re-handling of material
- Easy to move around site
- Natural stockpile capacity increased
- Quick set-up time

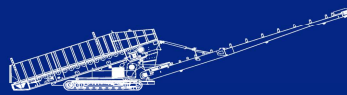

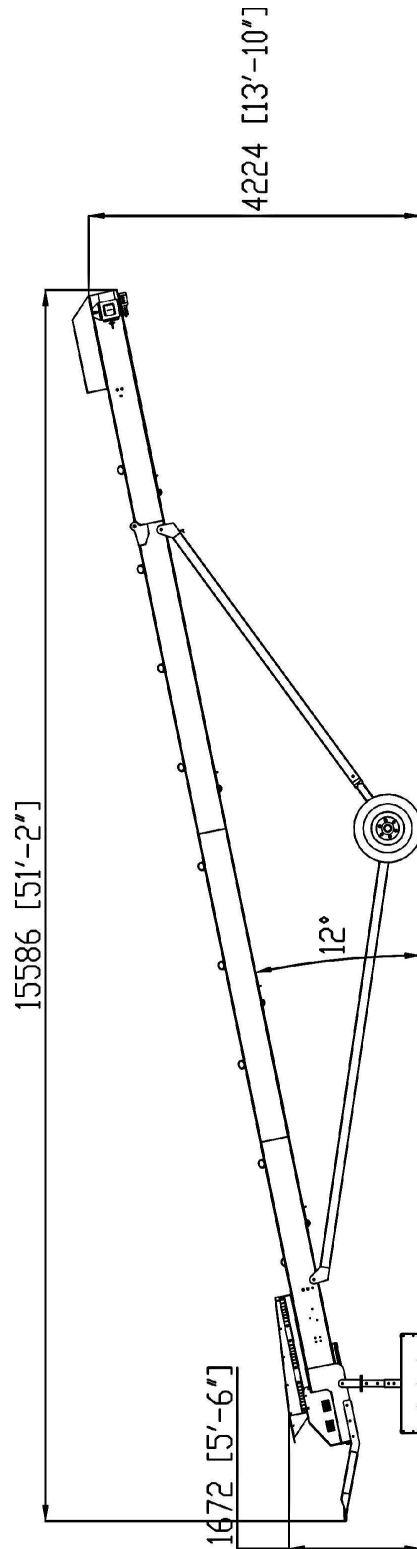

Fig. 1. MS50 Minimum Working Dimensions

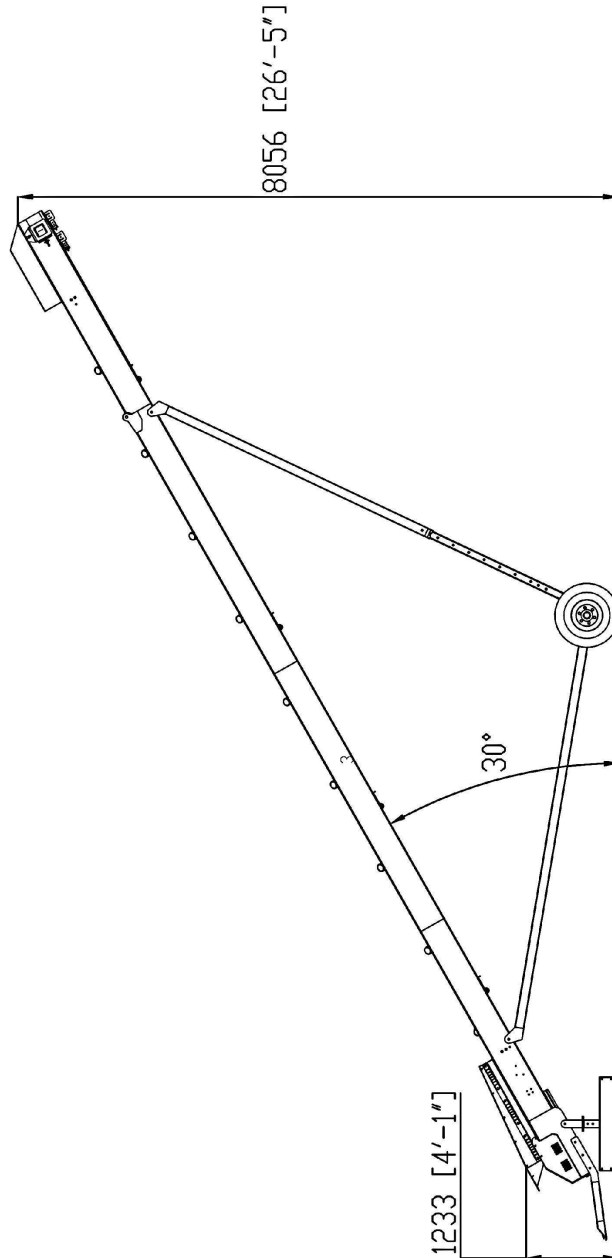

Fig. 2. Maximum Working Dimensions

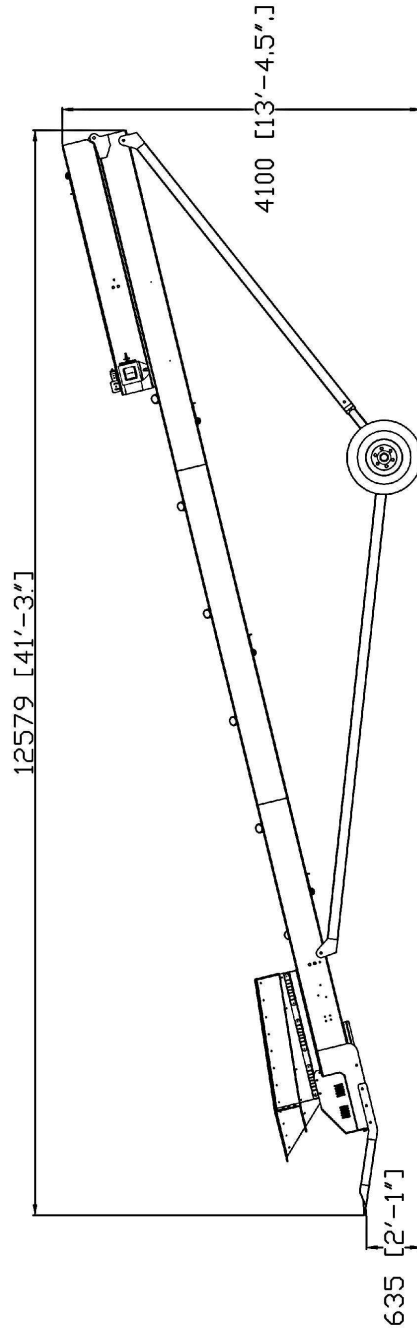

Fig. 3. Transit Dimensions