

BoomTruck™ 28105

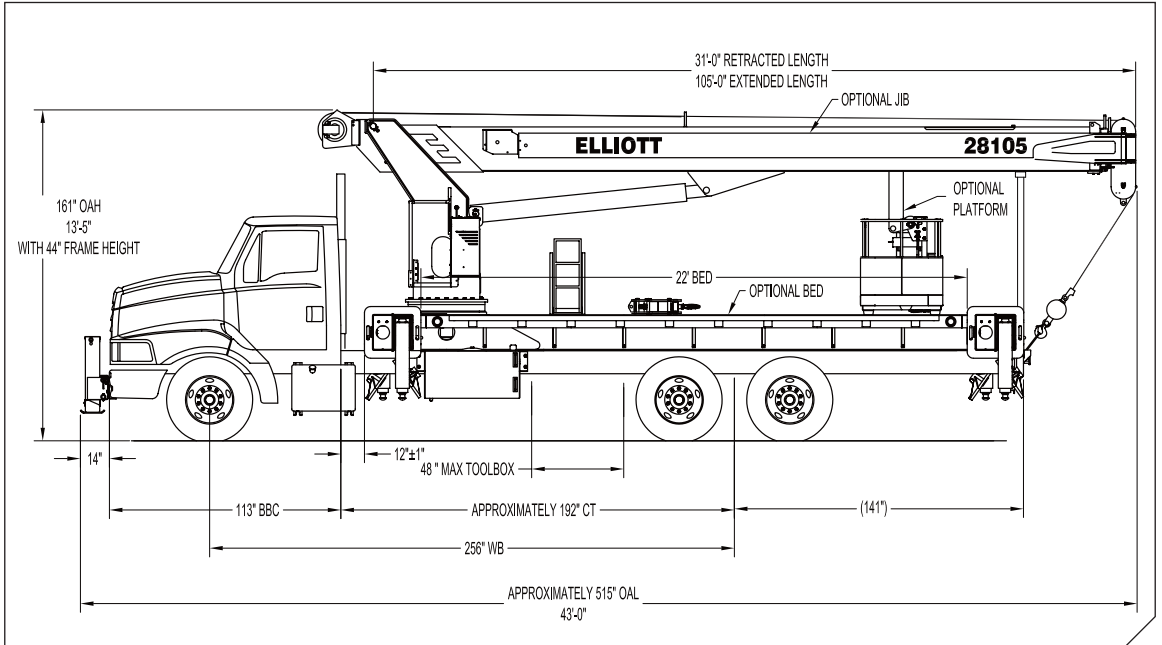

General Unit Description

BoomTruck – When it comes to design and engineering, Elliott’s BoomTruck is generations apart from the traditional crane—making it ideal for the exacting demands of today’s job sites. With an industry-leading 18-ton capacity on a single axle chassis, the BoomTruck delivers high performance with increased efficiency--from its high-speed outrigger set-up, boom extension and retraction to its high-pull winch. Plus our BoomTruck requires very little maintenance thanks to its layaway hoist, 10 percent fewer fittings than competitor models and the industry’s best warranty. That gives you time to enjoy operator amenities like the built-in cup holders and 12-volt charger on the operator console.

Basic unit includes base assembly supporting rotating turret, hydraulically powered rotation mechanism, oil reservoir, oil, and operator control console with levers linked to manual hydraulic control valve mounted to pedestal. Two sets of out-and-down overframe, hydraulically powered, individually controlled outriggers. High strength steel four section proportional telescoping boom with single telescoping cylinder and cable and sheave extension. Load Moment Indicator System with display and hydraulic function lockout for load capacities. Power take off and pump drive, pressure gauge, piston pump and holding valves on cylinders. Control console is equipped with Anti-Two-Block system, engine start/stop, variable speed throttle, horn, winch burst of speed, and outrigger motion alarm. Additional equipment includes triangle reflector kit, backup alarm, and fire extinguisher. Paint BoomTruck white, outriggers red, and bed and boxes black. Installed on chassis, tested and ready to operate. Unit certified to ANSI B30.5 for Mobile and Locomotive cranes.

Technical Specifications

Crane Capacity: 56,000 pounds at five feet load radius.

Maximum Tip Height: 117' height (162' with optional 45' jib)

Control Console: Rotating turret single operator control station equipped with four single axis control levers for the main crane controls. Operator station includes LMI display, bubble level gauge, engine start/stop switch, signal horn button, variable speed throttle switch, lifting capacity chart, range diagram chart, boom angle indicator, system pressure gauge, 12V DC power source, and cup holder. Independent ground level electric operated outrigger controls.

Boom: Four-section fully proportional, high strength steel plated rectangular tube sections. A maximum boom tip height of 117 feet mounted on a truck. The boom nose contains one floating upper sheave and three lower sheaves. Assembly includes heavy-duty cylinder fittings, pivot pins, and replaceable wear pads.

Winch: Mounted at the base of the boom for a long fleet angle and flat level spooling of cable. Winch is driven by a planetary reducer and powered by a hydraulic motor. Burst-of-speed winch provides increased line speed. The winch brake is spring applied, pressure release design. Supplied with 425" of 9/16" diameter rotation resistant wire rope with a single line pull of 8,900 pounds, and a downhaul ball with swivel hook for single part line.

Load Moment Indicator System: LMI system senses hoist cylinder pressures, boom length and boom angle with hydraulic function lockout. The display console is equipped with an integrated bar graph showing crane utilization, boom angle or boom length, a mode select/controls for main boom and jib operation, and an anti-two block with an audio/visual warning and shut-off functions to limit hook-boom point contact.

Outriggers: Two sets of out and down overframe outriggers with 20 foot span. Outriggers are configured for full span or mid span operation. Outriggers equipped with ball socket aluminum removable pads that stow on vertical outrigger legs.

Frame: Full length, all welded rigid 4-plate design sub-frame. Sub-frame allows for bolt-on addition 22' bed wings, with top plate of subbase serving as portion of the bed deck, to form a three-piece bed.

Turret: Turret is one-piece weldment. Turret rotates on large diameter ball bearing.

Rotation: Hydraulic motor drives turret through double reduction planetary swing drive for 372-degree non-continuous rotation. The swing drive system has a spring applied, pressure release brake.

Boom Extension: Incorporates a 2-stage hydraulic extension cylinder, attached to the largest boom section, with a proportional cable extension system driving the outermost sections.

Lift: One double acting full displacement, long stroke cylinder provides smooth and stable boom elevation. Holding valve prevents boom from lowering in event of hose failure.

Cylinders: All cylinders use microhoned cylinder tubing, chrome shafts, top grade packing and protective rod wipers. Cylinder-mounted holding valves provided on all load-holding cylinders.

Hoses: All high-pressure hose is wire braid reinforced with a minimum safety factor of 4 to 1.

Oil Tank Capacity: 120 gallon mounted to truck frame on roadside.

Hydraulic System: Equipped with cable-shift PTO, piston pump, SAE O-ring face seals on pressure lines, and a 10-micron return line filter. The control valve distributes all flow to the hoist system, swing circuit, and other crane functions. System is closed center type.

Cab Equipment: PTO cable and switch with indicator light installed in truck cab. U/L approved 5-BC dry chemical fire extinguisher installed in truck cab.

Operator Manual: One copy of operation, maintenance, safety and parts manual provided with each unit.

Installation: Unit installed on customer's truck, painted, system and tank filled with oil, tested, inspected, certified and ready to operate.

Standard Paint: Paint Hi-reach white, outriggers red, and bed and boxes black.

Bumper: Bureau of Motor Carrier Safety rear bumper.

Weight: Approximately 27,000 lbs. with 22' steel floor bed, less truck.

Truck Chassis Requirements: Approximately 192" C.A., 18,000 lb. front axle, 34,000 lb. rear axle, and 52,000 lb. GVWR required. Trucks must have extended rear frame, increased cooling, heavy duty front and rear springs, 12V electrical system with high capacity alternator, cab clearance stop/tail/backup lights, and I.D. lamps. Additional equipment to consider: front tow hook, pintle hook, mud and snow tires for highway use. Recommended GWR is minimum for BoomTruck with flatbed only. Contact factory when additional equipment is to be added.

Options

- 45' telescopic jib
- Radio remote control crane operation
- Radio operated remote for outrigger setup
- Open seated controls and cab (rear mount)
- Outrigger interlock system to allow working over one side of crane
- Hook block for 2/3-part line load
- Hook block for 4 part line load
- Rear mount
- Tool boxes
- Front jack for 360 degree crane operation
- Steel gravity level platform
- Continuous rotation
- Oil Cooler
- Miscellaneous Options Contact factory for details

PRELIMINARY MAIN BOOM LOAD RATINGS

LOAD RADIUS IN FEET	LOAD RATINGS IN LB WITH OUTRIGGERS AND STABILIZERS EXTENDED													
	LOADED BOOM ANGLE 31-41	LOADED BOOM ANGLE 46-41	LOADED BOOM ANGLE 51-41	LOADED BOOM ANGLE 56-41	LOADED BOOM ANGLE 61-41	LOADED BOOM ANGLE 66-41	LOADED BOOM ANGLE 71-41	LOADED BOOM ANGLE 76-41	LOADED BOOM ANGLE 81-41	LOADED BOOM ANGLE 86-41	LOADED BOOM ANGLE 91-41	LOADED BOOM ANGLE 96-41		
5	80	56,000												
6	78	44,000												
8	74.5	36,600	79.5	30,000										
10	70.5	31,000	77	27,000										
12	66.5	26,500	74	24,500	77.4	22,500								
14	62	20,500	71.5	21,800	75.4	19,800	78	18,500						
16	58	18,500	69	19,500	73.3	17,700	76.3	16,000	78.3	14,300				
18	53	14,000	66	15,800	71.1	16,000	74.5	14,850	76.9	13,700	79	12,600		
20	48	11,000	63	12,800	69	14,400	72.8	13,450	75.4	12,500	77.5	11,550		
25	32.5	6,900	55.5	7,800	63.5	11,500	68.4	10,900	71.7	10,300	74.5	9,750		
30			47	10,300	58.1	9,500	64.2	9,000	68.3	8,500	71.5	8,050		
35			38	8,500	51.8	7,900	59.4	7,500	64.4	7,050	68	6,650		
40			24.5	6,300	44.9	6,800	54.4	6,300	60.3	5,800	64.5	5,600		
45					36.9	5,700	49	5,300	56.1	5,000	61	4,700		
50					26.7	4,000	43.1	4,600	51.7	4,400	57.5	4,300		
55							38.3	3,800	46.9	3,800	54	3,800		
60							28.1	2,700	41.7	3,250	50	3,300		
65							18.1	1,600	35.9	2,700	45.5	2,800		
70									30	1,800	41	2,250		
75									19.9	1,400	36	1,900		
80										30	1,000	39.5	1,450	
85										22.5	800	34.5	1,150	
90												29.5	850	
95													22.5	600
0		10,000	0	6,200	0	4,100								
AUTO CAPACITIES (WHEN IN USE STORED IN)			600		450		400		350		300		250	
		350		350		300		250		200		150		150

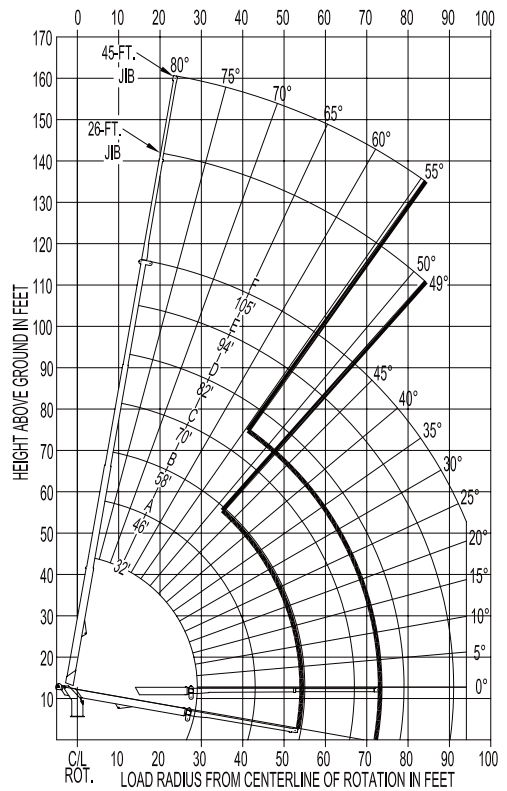

THIS AERIAL DEVICE IS NON-INSULATING. IT PROVIDES NO ELECTRICAL PROTECTION. CONTACT WITH OR INADEQUATE CLEARANCE TO AN ENERGIZED LINE OR APPARATUS IS AN ELECTROCUTION HAZARD.

