

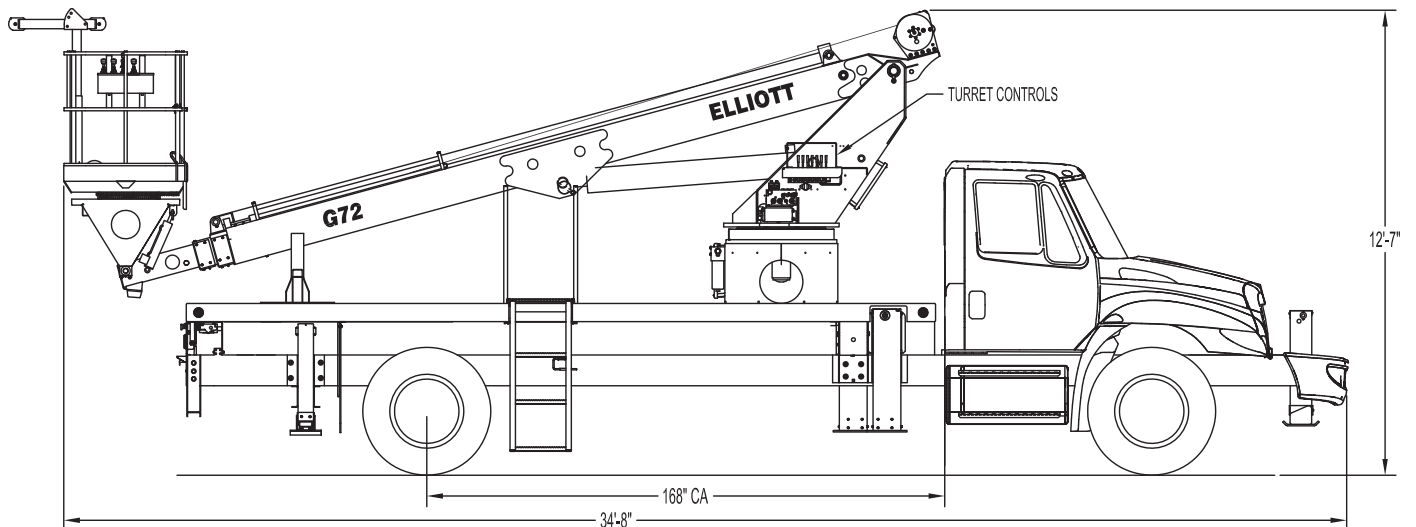

G72F SIDE VIEW DIAGRAM



- | | | | |
|--|---------------------|---|--------------------|
| • Working Height | 77'1/23,4 m | • Powered Boom Sections | 4 |
| • Working Side Reach | 61'1/18,6 m | • Overall Height | 12'7"/3,8 m |
| • Platform Capacity | 600 lbs/272 kg | • Unit Weight (Bare) | 17,200 lbs/7802 kg |
| • Platform Size | 40x60 in/102x152 cm | • Outrigger Spread Main | 18'5/5 m |
| • Platform Type | Top-Mount | • Outrigger Spread Auxiliary | 8'2,4 m |
| • Lifting Capacity (Main Winch) | 5,900 lbs/2676 kg | • Front Gross Axle Weight Rating | 13,000 lbs/5897 kg |
| • Jib Winch | 1,000 lbs/454 kg | • Rear Gross Axle Weight Rating | 20,000 lbs/9072 kg |

TECHNICAL SPECIFICATIONS

Maximum Platform Height: 72' ground to platform floor.

Working Range: 77' max. working height and 61' max. side reach.

Work Platform: 40x60" Top-Mount work platform with 40" high rails. Equipped with two safety lanyard attachment loops and two safety harnesses and 72" lanyards. Platform capacity 600 lbs.

Platform Leveling System: Hydraulic "closed" system consisting of twin platform cylinders interacting with a boom-actuated master cylinder mounted in boom support turret. System provided with factory-set relief valves to compensate for oil expansion or overload during platform leveling operation. Remote releveling controls provided in platform and at ground controls to give precise releveling capability.

Platform Controls: Three individual proportional electronic controllers meter pilot-operated, pressure-compensated modulating valves. Boom ground controls are mounted on curbside of turret. Remote controls for boom operations from platform operate from a removable remote control box. Hi/Lo range, start/stop and engine speed toggle controls are also located at platform. Electric remote control cable extends through the electrical slip ring to cable carrier on side of boom to extending boom sections.

Lower Controls: Mounted on curbside of turret.

Outrigger Controls: Parallel open-center stack valve for lever-operated control of right and left outriggers. The outrigger valves are mounted at the rear, under each corner of the bed with roadside valve controlling roadside outriggers and curbside valve controlling curbside outriggers.

Outriggers: One set of main "MH"

type out-and-down outriggers with 18' spread behind the cab. Secondary "A" type underslung outriggers at the rear with an 8' spread. Front stabilizer required for 360 degree stability.

Frame: One piece, all welded, box-type fabrication with integral outrigger mounts.

Turret: Reverse offset turret is one-piece weldment mounted on turret box. Turret rotates on large diameter ball bearing.

Rotation: Continuous turret rotation with no stops. Hydraulic motor drives turret through self-locking gear box.

Boom: Steel rectangular tube sections. Assembly includes heavy-duty cylinder fittings, pivot pins, and replaceable wear pads.

Boom Extension: Two opposing "piggyback" extension cylinders extend the boom sections.

Lift: One single-acting full displacement, long stroke cylinder, provides smooth and stable boom elevation. Holding valve prevent boom from falling in event of hose failure.

Cylinders: All cylinders use microhoned cylinder tubing, chrome shafts, top grade packing and protective rod wipers. Cylinder-mounted holding valves provided on all load-holding cylinders.

Hoses: All high pressure hoses are wire braid reinforced with a minimum safety factor of 4 to 1.

Oil Tank Capacity: 35 gallon mounted to truck frame on roadside.

Hydraulic System: Operating pressure approximately 2,500 PSI. System is parallel open center type and is equipped with liquid-filled pressure gauge. Oil is supplied to upper cylinders through hydraulic union in center of turret to cable carrier along side of the boom.

Pump: Gear type, direct mount to truck PTO.

PTO: Heavy-duty, high-speed.

Cab Equipment: PTO indicator lights installed in truck cab. Engine speed control and start/stop installed with control switches in platform remote control box and also located at lower controls. U/L approved 5:BC dry chemical fire extinguisher installed in truck cab.

Operators Manual & Video: Two CDs and one printed copy of operation, maintenance, safety and parts manual provided with each unit. Operational and safety video provided at delivery.

Installation: Unit installed on truck, painted, system and tank filled with oil, tested, inspected, and ready to operate.

Standard Paint: Paint boom and turret red, outriggers red, and bed and boxes black. Top of bed painted with black nonskid surface.

Bumper: Bureau of Motor Carrier Safety rear bumper.

Weight: Approximately 17,200 lbs. with 20' steel-floor bed less truck.

Truck Chassis Required: Approx. 156" C.A. RBM 1,600,000 in-lb. per rail, 13,000 lb. front axle and 33,000 lb. GVWR required. Trucks must have increased cooling, heavy-duty front and rear springs, 12V electrical system with high capacity alternator, cab clearance stop/tail/backup lights, and I.D. lamps. Extended front frame rails. Recommended GVWR is minimum for HiReach with flatbed only. Contact factory when additional equipment is to be added.

Options:

5,900 lb Capacity Boom Winch

1,000 lb Capacity Platform Jib

Welder, Air, and 110V Lines to Platform.

Much More....

Elliott Equipment Company reserves the right to change the specification of any unit at any time without prior notice. This brochure is only a statement of general specifications on the date of this publication. For more detailed info on specific Elliott trucks go to www.elliottequip.com

MAXIMUM WORKING RANGE

PLATFORM WORKING RANGE
MODEL G72

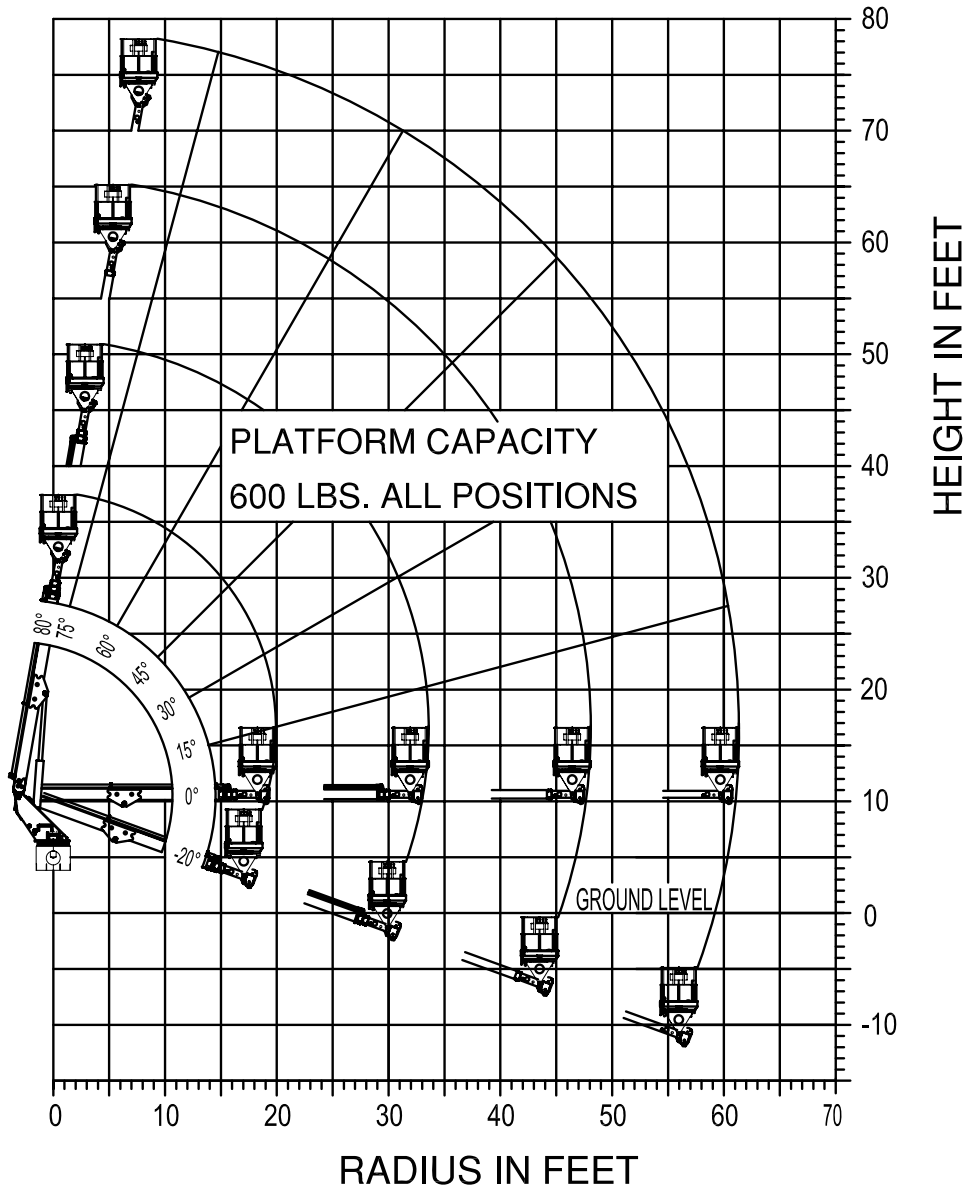

ELLIOTT
EQUIPMENT COMPANY

1192820 042913

MAXIMUM LIFTING CAPABILITIES



MODEL G72

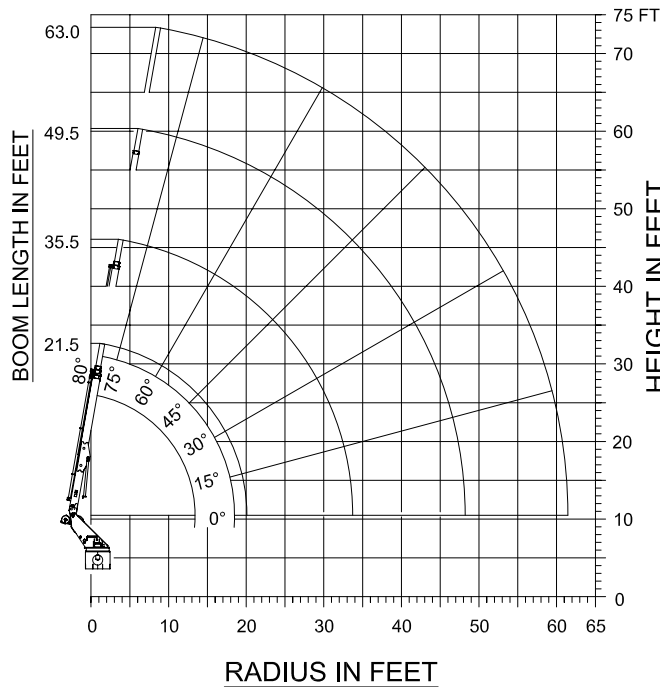

DO NOT PAINT OVER ANY LABELS

**MAXIMUM WORKING LOADS
CRANE OPERATION**

WINCH LINE LOAD (POUNDS) ON BOOM
SHEAVE WITH PLATFORM REMOVED.

RADIUS (FT.)	21.5' BOOM LENGTH		35.5' BOOM LENGTH	
	ANGLE (DEG.)	LOAD (LBS.)	ANGLE (DEG.)	LOAD (LBS.)
2	80	5,900		
4	75	5,900		
5	73	5,900	80	2,500
7	65	5,900	75	2,500
9	60	5,900	71	2,500
14	45	5,900	63	2,500
16	35	5,900	60	2,500
17	30	5,900	57	2,500
19	15	5,900	53	2,500
20	0	5,900	52	2,500
23			45	2,500
29			30	2,500
32			15	2,500
33			0	2,500

RADIUS (FT.)	49.5' BOOM LENGTH		63.0' BOOM LENGTH	
	ANGLE (DEG.)	LOAD (LBS.)	ANGLE (DEG.)	LOAD (LBS.)
8	80	1,800		
10	77	1,800	80	1,800
11	75	1,800	78	1,800
14	71	1,700	75	1,800
23	60	1,700	66	1,700
30	51	1,400	60	1,700
33	45	1,300	56	1,500
42	30	1,200	46	1,300
43	26	1,100	45	1,300
46	15	1,100	40	1,200
48	0	1,100	38	1,200
53			30	1,200
59			15	1,100
61			0	1,100

USE OUTRIGGERS AT ALL TIMES * AVOID JERKING LOADS 360°

* USE 2 PART LINE FOR LOADS OVER 2,500 LBS.

DEDUCT 500 LBS. WITH PLATFORM ATTACHED

1133430 020803



Elliott Equipment Company Phone: 402-592-4500
4427 South 76th Circle Fax: 402-592-4553
Omaha, NE 68127 Email: sales@elliottequip.com

Built for You.
www.elliottequip.com

MAXIMUM JIB LIFTING CAPABILITIES

**MAXIMUM WORKING LOADS
1,000 LBS. PLATFORM JIB OPERATION**

MODEL G72

TOTAL PLATFORM CAPACITY (JIB LOAD PLUS PERSONNEL)

USE OUTRIGGERS AT ALL TIMES • AVOID JERKING LOAD
360° BOOM RADIUS

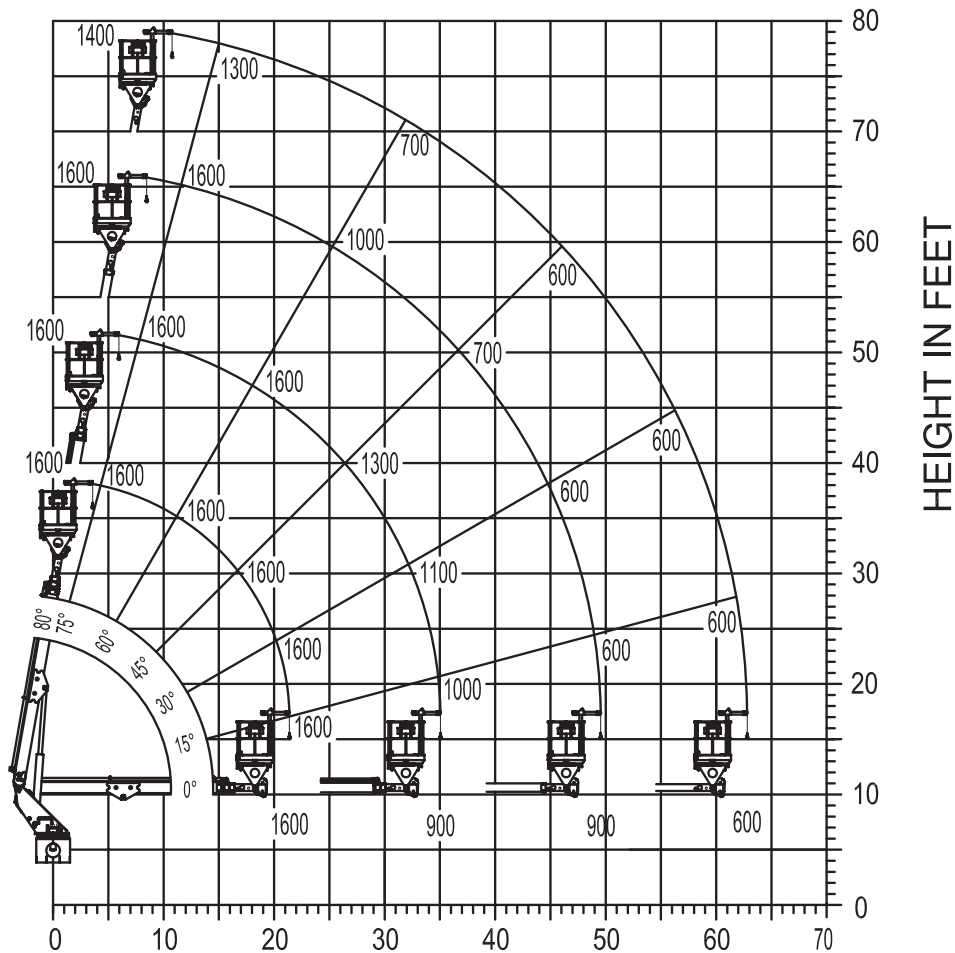

RADIUS IN FEET
JIB 1,000 LBS. MAX. PERSONNEL 600 LBS. MAX.



Elliott Equipment Company Phone: 402-592-4500
4427 South 76th Circle Fax: 402-592-4553
Omaha, NE 68127 Email: sales@elliottequip.com

Built for You.
www.elliottequip.com

CHASSIS DATA

	G72F
Wheelbase (WB)	222" / 564 cm
Cab to Axle (CA)	168" / 427 cm
Cab to End of Frame (EOF)	256" / 650 cm
Frame Section Modulus	13.3 in3 / 120,000 psi
Front Axle Gross Weight Rating	13,000 lb / 5896 kg
Rear Axle Gross Weight Rating	20,000 lb / 9072 kg
Extended Front Frame	Required for Front Stabilizer

Chassis data is minimum general requirements-not for engineering.
Actual dimensions and truck data will depend on truck selection and axle configuration.

OPTIONS



MH Outriggers With Shortjacking

Reduce outrigger spread with MH outriggers behind the cab and Elliott's automatic safety rotation lockout to operate your HiReach in confined spaces.



Material Handling Jib

Equip your HiReach platform with a material handling jib crane to handle up to 1,000 pounds.



Boom-Mounted Winch

Take advantage of the 5,900 lb capacity 2 speed hydraulic winch with 1/2" cable.



Outrigger Pad Holders

Outrigger pad holders safely store your pads for travel and leave plenty of room for tool boxes.



Bed Accessories

Mount a wide variety of tool accessories including welders, power washers, and generators on the bed with lines to the platform.



Platform Accessories

Choose from a list of platform accessories including 110V outlets, welding leads, hydraulic tools, and much more.



Outrigger Extensions

Our pin-on outrigger extensions give you extra clearance for work on hills and around guardrails.



Line Body

Let us work with you to customize a line body to secure your tools and supplies the the best way for your application.