

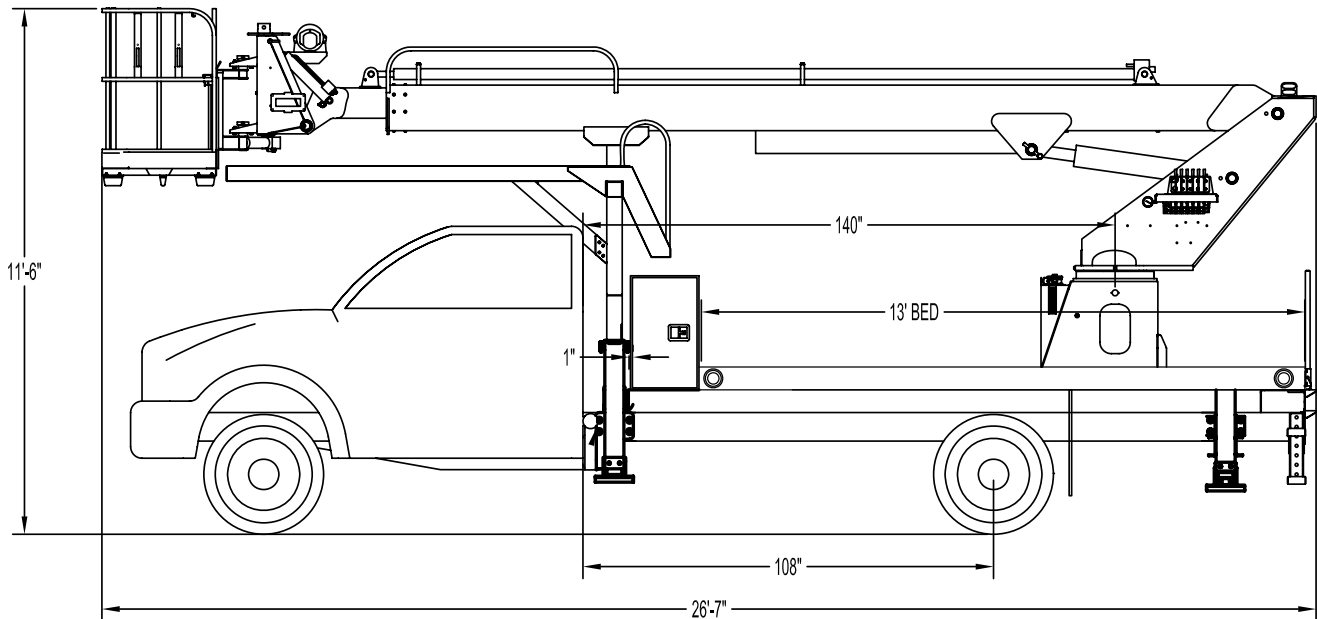

M43 SIDE VIEW DIAGRAM



- | | | | |
|--|--------------------|---|--------------------|
| • Working Height | 48'/14,6 m | • Powered Boom Sections | 2 |
| • Working Side Reach | 36'/11 m | • Overall Height | 11'7"/3,5 m |
| • Platform Capacity | 500 lbs/227 kg | • Unit Weight (Bare) | 8,400 lbs/3,810 kg |
| • Platform Size | 30x54 in/76x137 cm | • Outrigger Spread Main | 10'5"/3,2 m |
| • Platform Type | EZR | • Outrigger Spread Auxiliary | 8'/2,4 m |
| • Lifting Capacity (Main Winch) | N/A | • Front Gross Axle Weight Rating | 7,000 lbs/3175 kg |
| • Jib Winch | 500 lbs/227 kg | • Rear Gross Axle Weight Rating | 12,500 lbs/5670 kg |

TECHNICAL SPECIFICATIONS

Maximum Platform Height: 43' ground to platform floor.

Working Range: 48' max. working height and 36' max. side reach.

Work Platform: 30"x54" EZR end-hung work platform with 40" high rails. Equipped with two safety lanyard attachment loops and two safety harnesses and 72" lanyards. Platform capacity 500 lbs.

Platform Leveling System: Hydraulic system consisting of twin platform cylinders interacting with electro-proportional level sensing system. Remote releveling controls provided in platform and at ground controls to give precise leveling capability.

Platform Controls: Three individual proportional electronic controllers meter pilot-operated, pressure-compensated modulating valves. Remote controls for boom operations from platform operate from a removable remote control box. Hi/Lo range, start/stop and engine speed toggle controls are also located at platform. Electric remote control cable extends through the electrical slip ring to cable carrier on side of boom to extending boom sections.

Lower Controls: Mounted on roadside of turret.

Outrigger Controls: Parallel open-center valve for lever-operated control of right and left outriggers. The outrigger valves are mounted at the rear, under each corner of the bed with roadside valve controlling roadside outriggers and curbside valve controlling curbside outriggers.

Outriggers: Vertical stabilizers with 8' spread and "A" type underslung outriggers with 10'5" spread.

Frame: One piece, all welded, box-type fabrication.

Turret: Reverse offset turret is one-piece weldment mounted on turret box. Turret

rotates on large diameter ball bearing.

Rotation: Continuous turret rotation with no stops. Hydraulic motor drives turret through self-locking gear box.

Boom: Steel rectangular tube sections. Assembly includes heavy-duty cylinder fittings, pivot pins, and replaceable wear pads.

Boom Extension: Single extension cylinder to extend the boom section.

Lift: One single-acting full displacement, long stroke cylinder, provides smooth and stable boom elevation. Holding valve prevents boom from falling in event of hose failure.

Cylinders: All cylinders use microhoned cylinder tubing, chrome shafts, top grade packing and protective rod wipers. Cylinder-mounted holding valves provided on all load-holding cylinders.

Hoses: All high pressure hoses are wire braid reinforced with a minimum safety factor of 4 to 1.

Oil Tank Capacity: 18 gallon mounted to turret box.

Hydraulic System: Operating pressure is 2,250 PSI. System is parallel open center type and is equipped with liquid-filled pressure gauge. Oil is supplied to upper cylinders through hydraulic union in center of turret to cable carrier inside of the boom.

Pump: Gear type, direct mount to truck PTO.

PTO: Heavy-duty, high-speed. Cable engaged from cab.

Cab Equipment: PTO cable or switch with indicator lights installed in truck cab. Engine speed control and start/stop installed with control switches in platform remote control box and also located at lower controls. U/L approved 5:BC dry chemical fire extinguisher installed in truck cab.

Operators Manual & Video: Two CDs and one printed copy of operation, maintenance, safety and parts manual provided with each unit. Operational and safety video provided at delivery.

Installation: Unit installed on truck, painted, system and tank filled with oil, tested, inspected, and ready to operate.

Standard Paint: Paint boom and turret red, outriggers red, and bed and boxes black. Top of steel bed painted with black nonskid surface.

Bumper: Bureau of Motor Carrier Safety rear bumper.

Weight: Approximately 8,400 lbs. with 14'6" steel-floor bed less truck.

Truck Chassis Required: Approx. 108" C.A., 7,000 lb. front axle and 19,500 lb. GVWR required. Trucks must have increased cooling, heavy-duty front and rear springs, 12V electrical system with high capacity alternator, cab clearance stop/tail/backup lights, and I.D. lamps. Recommended GVWR is minimum for HiReach with flatbed only. Contact factory when additional equipment is to be added.

Options:

98" x 18" x 18" Steel Cross Body Box.

500 lb Capacity Platform Material Handling Jib.

110 Volt Line to Platform.

Modified Outriggers for 25,999 GVWR chassis.

Much More....

Elliott Equipment Company reserves the right to change the specification of any unit at any time without prior notice. This brochure is only a statement of general specifications on the date of this publication. For more detailed info on specific Elliott trucks go to www.elliottequip.com

MAXIMUM JIB LIFTING CAPACITY

**MAXIMUM WORKING LOADS
PLATFORM JIB OPERATION**

MODEL M43

TOTAL PLATFORM CAPACITY (JIB LOAD PLUS PERSONNEL)

USE OUTRIGGERS AT ALL TIMES • AVOID JERKING LOAD

360° RADIUS

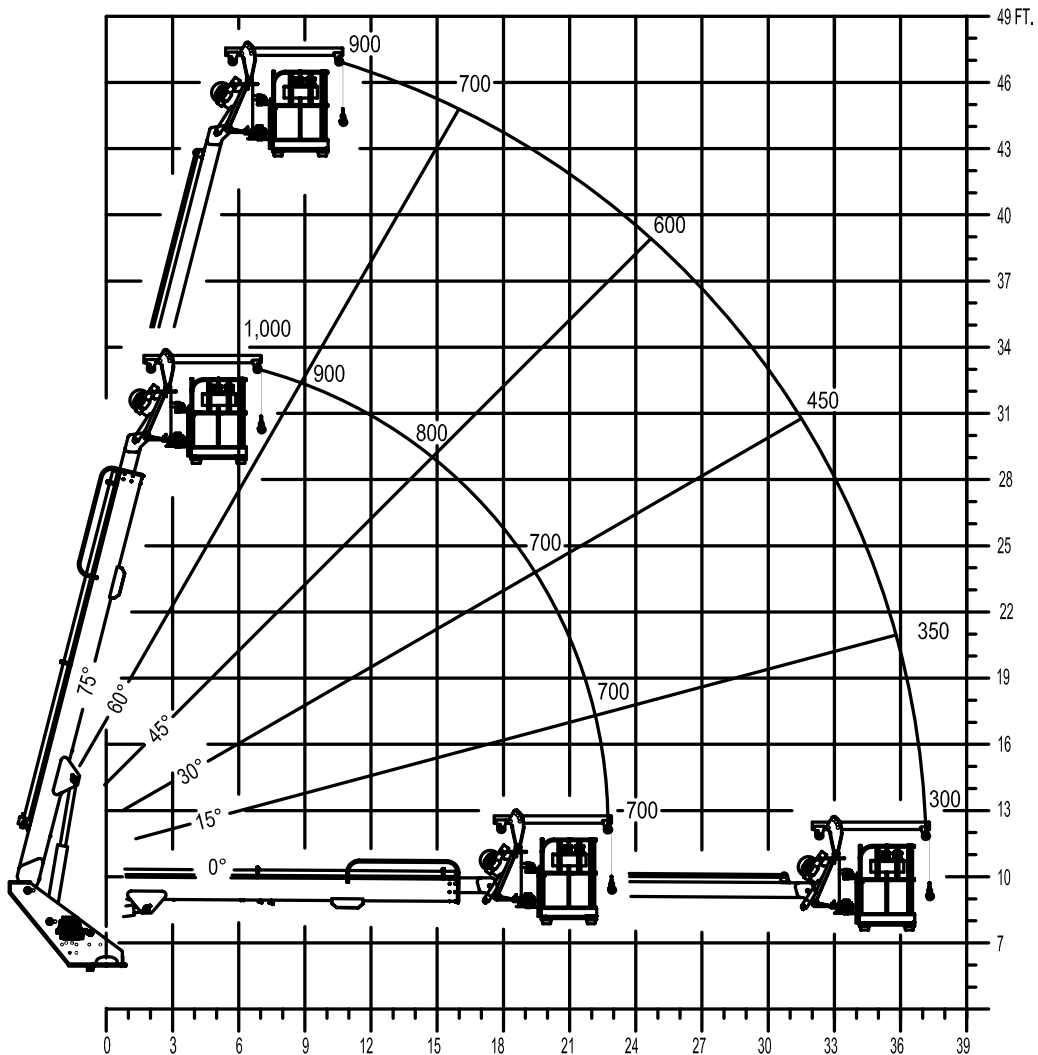

JIB 500 LBS. MAXIMUM • PERSONNEL 500 LBS. MAXIMUM

CHASSIS DATA

	M43
Wheelbase (WB)	192.5" / 489 cm
Cab to Axle (CA)	108" / 274 cm
Cab to End of Frame (EOF)	190" / 483 cm
Front Axle Gross Weight Rating	7,000 lb / 3,175 kg
Rear Axle Gross Weight Rating	12,500 lb / 5,670 kg
Extended Front Frame	N/A

Chassis data is minimum general requirements-not for engineering.
Actual dimensions and truck data will depend on truck selection and axle configuration.

OPTIONS

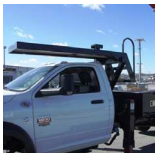

Walkway Access to Platform

Install a steel platform walkway above the cab for easy platform access with the boom stowed in the over-cab position.



Material Handling Jib

Equip your HiReach platform with a removable material handling jib crane to handle up to 500 pounds.



Non-CDL Chassis Options

Take advantage of the low chassis GVWR requirements by mounting your HiReach on a non-CDL truck chassis.



Outrigger Pad Holders

Outrigger pad holders safely store your pads for travel and leave plenty of room for tool boxes.



Bed Accessories

Mount a wide variety of tool accessories including welders and generators on the bed with leads to the platform.

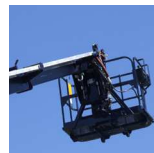

Platform Accessories

Choose from a list of platform accessories including 110V outlets.



Custom Design Engineering

Customize your HiReach by adding lights, tools, special paint, and much more. Let Elliott's engineering team design the right configuration for your business.



Line Body

Let us work with you to customize a line body to secure your tools and supplies the the best way for your application.