

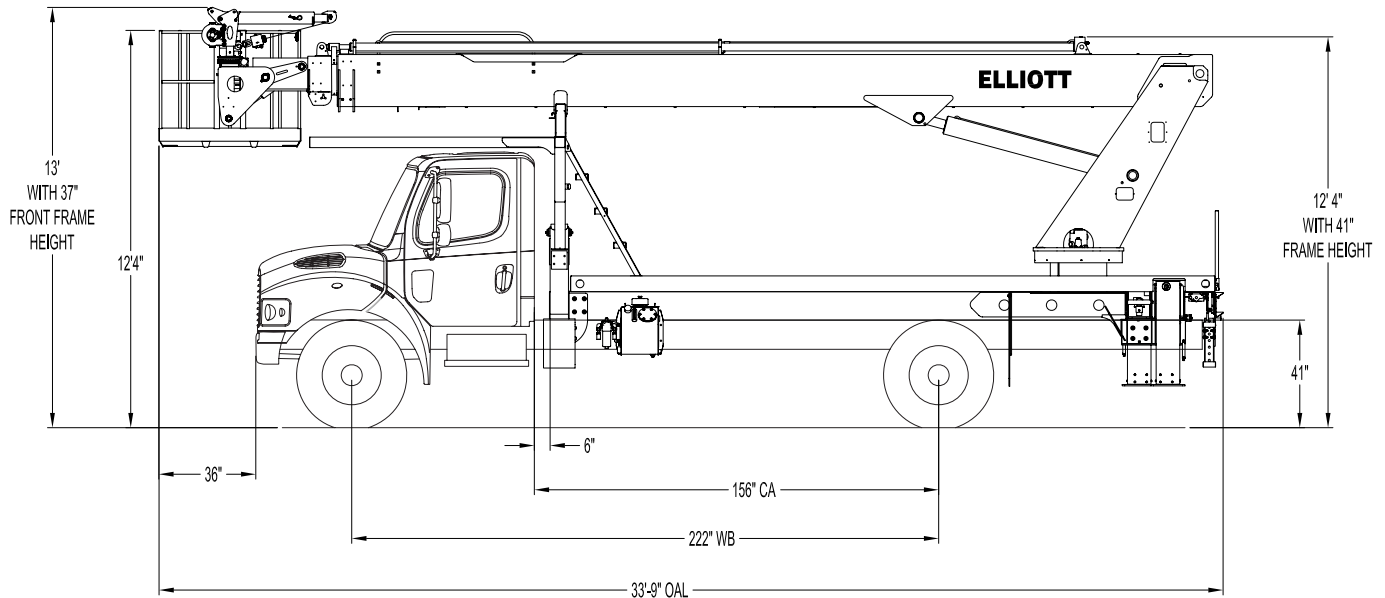

M85 SIDE VIEW DIAGRAM



- | | | | |
|--|----------------------|---|------------------------|
| • Working Height | 87' / 26,5 m | • Powered Boom Sections | 3 |
| • Working Side Reach | 74' / 22,5 m | • Overall Height | 13' / 4 m |
| • Platform Capacity | 750 lbs / 340 kg | • Unit Weight (Bare) | 13,500 lbs / 6123 kg |
| • Platform Size | 30x54 in / 76x137 cm | • Outrigger Spread Main | 18' / 5,5 m |
| • Platform Type | End-Hung | • Outrigger Spread Auxiliary | 12' / 3,6 m |
| • Lifting Capacity (Main Winch) | N/A | • Front Axle Gross Weight Rating | 10,000 lbs / 4536 kg |
| • Jib Winch | 500 lbs / 227 kg | • Minimum Vehicle GVWR | 25,999 lbs / 11 793 kg |

TECHNICAL SPECIFICATIONS

Maximum Platform Height: 82' ground to platform floor.

Working Range: 87' max. height and 74' max. side reach.

Work Platform: 30"x54" non-removable end-mount work platform with 40" high rails. Equipped with two safety lanyard attachment loops and two safety harnesses and 72" lanyards. Platform capacity 750 lbs.

Platform Leveling System: Hydraulic system consisting of a single platform cylinder interacting with electro-proportional level sensing system. Remote releveling controls provided in platform and at ground controls to give precise leveling capability.

Platform Controls: Three individual proportional electronic controllers meter pilot-operated, pressure-compensated modulating valves. Remote controls for boom operations from platform operate from a removable remote control box. Hi/Lo range, start/stop and engine speed toggle controls are also located at platform. Electric remote control cable extends through the electrical slip ring to cable carrier inside of boom to extending boom sections.

Lower Controls: Mounted on curbside of turret.

Outrigger Controls: Parallel open-center valve for lever-operated control of right and left outriggers. The outrigger valves are mounted at the rear, under each corner of the bed with roadside valve controlling roadside outriggers and curbside valve controlling curbside outriggers.

Outriggers: "A" frame auxiliary outriggers with a 12' spread, and "MH" out-and-down main outriggers with an 18' spread.

Frame: One piece, all welded, box-type fabrication.

Turret: Reverse offset turret is one-

piece weldment. Turret rotates on large diameter ball bearing.

Rotation: Continuous turret rotation with no stops. Hydraulic motor drives turret through dual self-locking gear box.

Boom: Steel rectangular tube sections. Assembly includes heavy-duty cylinder fittings, pivot pins, and replaceable wear pads.

Boom Extension: Single extension cylinder and cables extend the boom sections proportionally.

Lift: One single-acting full displacement, long stroke cylinder, provides smooth and stable boom elevation. Holding valve prevent boom from falling in event of hose failure.

Cylinders: All cylinders use microhoned cylinder tubing, chrome shafts, top grade packing and protective rod wipers. Cylinder-mounted holding valves provided on all load-holding cylinders.

Hoses: All high pressure hoses are wire braid reinforced with a minimum safety factor of 4 to 1.

Oil Tank Capacity: 19 gallon mounted to the truck frame.

Hydraulic System: Operating pressure approximately 2,750 PSI. System is parallel open center type and is equipped with liquid-filled pressure gauge. Oil is supplied to upper cylinders through hydraulic union in center of turret to cable carrier inside of the boom.

Pump: Gear type, direct mount to truck PTO.

PTO: Heavy-duty, high-speed. Cable engaged from cab.

Cab Equipment: PTO cable or switch with indicator lights installed in truck cab. Engine speed control and start/stop installed with control switches in platform remote control box and also located at lower controls. U/L approved 5:BC dry chemical fire extinguisher

installed in truck cab.

Operators Manual & Video: Two CDs and one printed copy of operation, maintenance, safety and parts manual provided with each unit. Operational and safety video provided at delivery.

Installation: Unit installed on truck, painted, system and tank filled with oil, tested, inspected, and ready to operate.

Standard Paint: Paint boom and turret red, outriggers red, and bed and boxes black. Top of steel bed painted with black nonskid surface.

Bumper: Bureau of Motor Carrier Safety rear bumper.

Weight: Approximately 13,500 lbs. with 20'6" steel-floor bed less truck.

Truck Chassis Required: Approx. 156" C.A., 10,000 lb. front axle and 25,999 lb. GVWR required. Trucks must have increased cooling, heavy-duty front and rear springs, 12V electrical system with high capacity alternator, cab clearance stop/tail/backup lights, and I.D. lamps. Recommended GVWR is minimum for HiReach with flatbed only. Contact factory when additional equipment is to be added.

Options:

98" x 36" x 24" Steel Cross Body Box.

500 lb Capacity Platform Material Handling Jib.

Air and 110 Volt Lines to Platform.

Much More...

Elliott Equipment Company reserves the right to change the specification of any unit at any time without prior notice. This brochure is only a statement of general specifications on the date of this publication. For more detailed info on specific Elliott trucks go to www.elliottequip.com

MAXIMUM RANGE AND JIB CAPABILITIES

**MAXIMUM WORKING LOADS
750 LBS. PLATFORM JIB OPERATION**

MODEL M85

TOTAL PLATFORM CAPACITY (JIB LOAD PLUS PERSONNEL)

USE OUTRIGGERS AT ALL TIMES AVOID JERKING LOAD

360° RADIUS

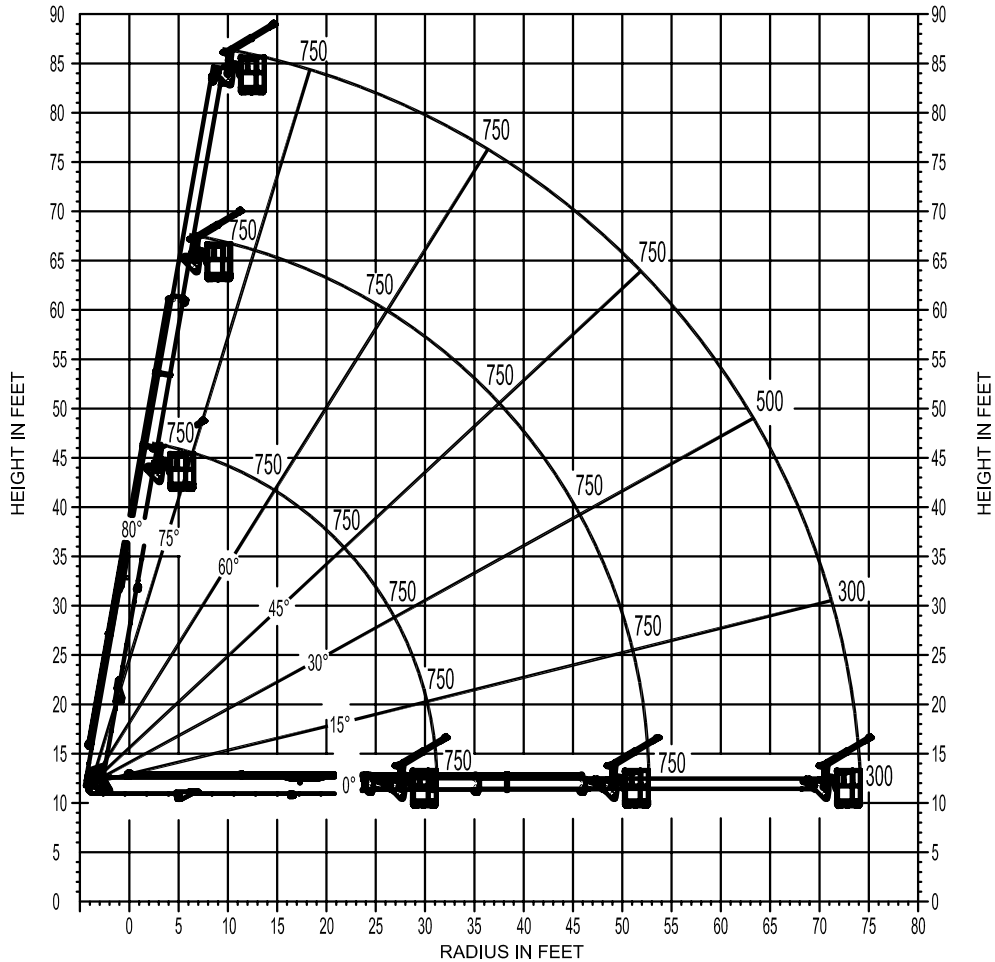

JIB 500 LBS. MAXIMUM PERSONNEL 750 LBS. MAXIMUM

ELLIOTT

EQUIPMENT COMPANY

DO NOT PAINT OVER ANY LABELS

1164250 04182011

Elliott Equipment Company reserves the right to change the specification of any unit at any time without prior notice. This brochure is only a statement of general specifications on the date of this publication. For more detailed info on specific Elliott trucks go to www.elliottequip.com



Elliott Equipment Company
4427 South 76th Circle
Omaha, NE 68127
Phone: 402-592-4500
Fax: 402-592-4553
Email: sales@elliottequip.com

Built for You.
www.elliottequip.com

CHASSIS DATA

	M85
Wheelbase (WB)	222" / 655 cm
Cab to Axle (CA)	156" / 488 cm
Cab to End of Frame (EOF)	273" / 820 cm
Frame Section Modulus	10.8 in ³ / 120,000 psi
Front Axle Gross Weight Rating	10,000 lb / 4536 kg
Rear Axle Gross Weight Rating	19,000 lb / 8618 kg
Extended Front Frame	N/A

Chassis data is minimum general requirements-not for engineering.
Actual dimensions and truck data will depend on truck selection and axle configuration.

OPTIONS



Non-CDL Chassis Options

Take advantage of the low chassis GVWR requirements by mounting your HiReach on a non-CDL truck chassis.



Material Handling Jib

Equip your HiReach platform with a hydraulic material handling jib crane to handle up to 500 lbs.

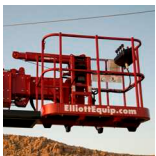

High Capacity Platform

Take advantage of the 750 lb capacity work platform by carrying additional tools and supplies onto the job site.



Outrigger Pad Holders

Outrigger pad holders safely store your outrigger pads for travel and leave plenty of room for tool boxes.



Bed Accessories

Mount a wide variety of accessories including generators and inverters.

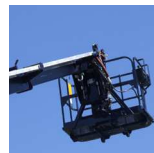

Platform Accessories

Choose from a list of platform accessories including 110V outlets, 3/8" air lines, sign forks, and much more.

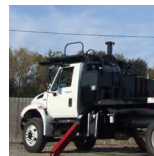

Walkway Platform Access

Select Elliott's walkway access to the platform to easily step into the platform from the bed with the boom stowed.



Line Body

Let us work with you to customize a line body to secure your tools and supplies the best way for your application.