

HYDRA 10



Hydraulic Mobile Pick 'n' Carry Crane of 11.4T Capacity

THE POWER OF LIFT



Pick 'n' Carry Crane Hydra-10

SALIENT FEATURES :

- 2 Part telescopic boom hydraulically extendable for more outreach and high lift.
- Specifically built long chassis for more reliability.
- Heavy duty transmission specifically designed for crane application.
- Articulated chassis for short turning radius.
- New Technology Control Valve for precision handling

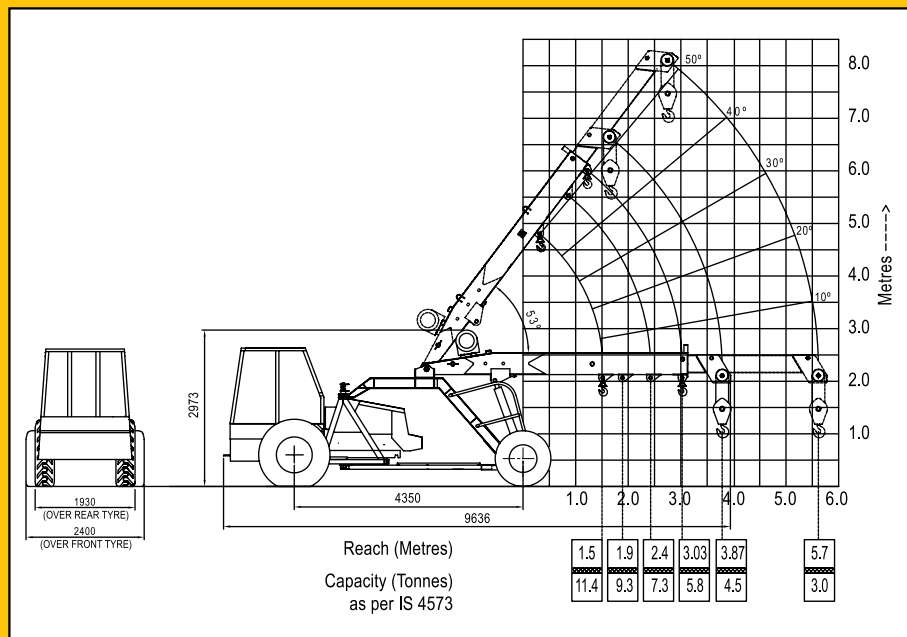

Specifications :

Engine

Make & Model Simpson S-433 Four Cylinder, Water Cooled Diesel Engine
Rated power for crane 49 BHP @ 2200 RPM
(Max continuous engine rating 59 @ 2300 RPM)
or equivalent Engine.

Transmission

Type Heavy duty transmission developed specially for crane application
Sliding Mesh, spur teeth gearbox. Six forward and two reverse speeds with high and low selector lever.

Speed Travel Speed 25 Kmph - restricted as per safety norms (without load)

Clutch Single plate, heavy duty dry friction type clutch plate specially designed for crane application.

Steering

Type Articulated power steering, hydraulically controlled through 2 double acting jacks

Articulation upto 56°

Turning Radius Minimum 5.2 m

Operational Timings (no load at rated engine RPM)

Steering (lock to lock) 6-10 secs

Boom Raising 18-22 secs

Boom Lowering 14-18 secs

Telescoping Extension in 7-8 secs

Telescoping Extension out 9-11 secs

Hoist Line Speed 24m/min (Single line)

Brakes

Front Wheel Pneumatically assisted hydraulic brakes

Rear Wheel Mechanical shoe brakes actuated through a slave cylinder

Parking Mechanically actuated at rear wheels

Track

Front 1880 mm (center of twin wheels)

Rear 1570 mm (center of wheels)

Tyres

Front 11.00x20-16 PR(Four Nos.)

Rear 13.00x24-12 PR(Two Nos.)

Boom

Telescoping Heavy duty, Two-part box type hydraulically operated

Derricking Through double acting jacks

Hoist Mechanism

Hoist Four falls, hydraulic winch. Rope dia 13 mm

Hydraulic System

Pump Pin Vane Type Hydraulic pump

Control Valve 4 spool control valve with built in pressure relief valve for precision control

Hydraulic Filter Suction line has a 100 mesh inline strainer while return line has 25 micron full flow filter

Electrical System

Type 12V Single battery, Negative earth

Capacities

Fuel Tank 45 Ltrs.

Hydraulic Tank 90 Ltrs.

Axle Reduction 2.45 Ltrs.

Operating Weight (kgs) 8450

Safety System

- Overload audio warning system
- Safety brakes on hoist
- Cylinder guard for protection
- Overhoist audio warning system
- Hose protection failure device

Standard Accessories

- All weather cabin
- Lift cylinder guard
- Front Bumper
- Rear view mirror
- Reflectors
- Turn and Reverse lamp

Optional Accessories

- Fly jib : 4.1m length
- Air conditioned cabin
- Safe load indicator with hydraulic cut-off
- Fire Extinguisher
- Steering wheel
- Spark Arrestor
- Extra hooks



ESCORTS CONSTRUCTION EQUIPMENT LIMITED

Plot No: 219, Sector-58, Ballabgarh, Faridabad (Haryana) - 121 004, India

Tel.: (0129) 2306300/2306570, Fax: (0129) 2306463

E-mail: marketing@escorts-ece.com, Website: www.ece.com