

# TOWER CRANE

## M220D

### TECHNICAL DATA SHEET

BOOM	LOAD @ RADIUS
90 ft	33.1 ton @ 32 ft 13.2 ton @ 82 ft
105 ft	33.1 ton @ 32 ft 10.5 ton @ 98 ft
120 ft	33.1 ton @ 33 ft 8.3 ton @ 115 ft
135 ft	33.1 ton @ 33 ft 6.5 ton @ 131 ft
150 ft	33.1 ton @ 16 ft 5.6 ton @ 139 ft
165 ft	29.8 ton @ 16 ft 4.4 ton @ 156 ft
180 ft	24.3 ton @ 16 ft 3.3 ton @ 172 ft

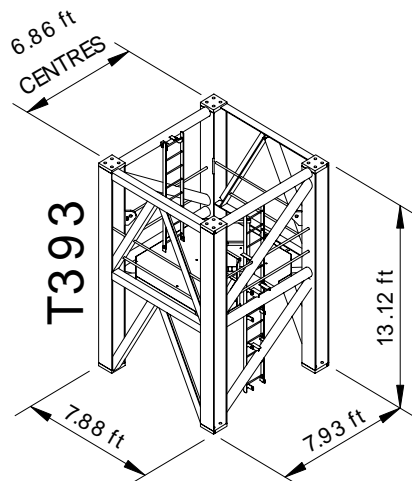

[www.favellefavco.com](http://www.favellefavco.com)

1-FALL								
Boom Length (feet)		180	165	150	135	120	105	90
Min Radius (feet)		15	14	13	12	11	10	9
SWL at Min Radius (ton)		17.6	17.6	17.6	17.6	17.6	17.6	17.6
Radius (feet)	16	Capacity (ton)	17.6	17.6	17.6	17.6	17.6	17.6
	33		17.6	17.6	17.6	17.6	17.6	17.6
	49		17.3	17.6	17.6	17.6	17.6	17.6
	66		14.9	16.0	16.3	16.6	17.0	17.2
	82		11.6	12.0	12.2	12.6	12.9	13.2
	98		9.0	9.3	9.6	9.8	10.3	10.5
	115		7.1	7.4	7.7	7.9	8.3	-
	131		5.6	6.0	6.3	6.5	-	-
	139		5.0	4.7	5.6	-	-	-
	148		4.5	4.5	-	-	-	-
	156		3.9	4.4	-	-	-	-
172	3.3	-	-	-	-	-		
Max Radius (feet)		172	156	139	131	115	98	82
SWL at Max Radius (ton)		3.3	4.4	5.6	6.5	8.3	10.5	13.2

2-FALL								
Boom Length (feet)		180	165	150	135	120	105	90
Min Radius (feet)		15	14	13	12	11	10	9
SWL at Min Radius (ton)		24.3	33.1	33.1	33.1	33.1	33.1	33.1
Radius (feet)	16	Capacity (ton)	24.3	29.8	33.1	33.1	33.1	33.1
	33		22.0	25.4	29.2	33.1	33.1	33.1
	49		17.3	21.3	22.8	22.3	23.5	23.7
	66		14.9	16.0	16.3	16.6	17.0	17.2
	82		11.6	12.0	12.2	12.6	12.9	13.2
	98		9.0	9.3	9.6	9.8	10.3	10.5
	115		7.1	7.4	7.7	7.9	8.3	-
	131		5.6	6.0	6.3	6.5	-	-
	139		5.0	4.7	5.6	-	-	-
	148		4.5	4.5	-	-	-	-
	156		3.9	4.4	-	-	-	-
172	3.3	-	-	-	-	-		
Max Radius (feet)		172	156	139	131	115	98	82
SWL at Max Radius (ton)		3.3	4.4	5.6	6.5	8.3	10.5	13.2

Note: All charts are for information only and should not be used for lifting purposes. Favelle Favco reserves the right to make specification changes without prior notice.

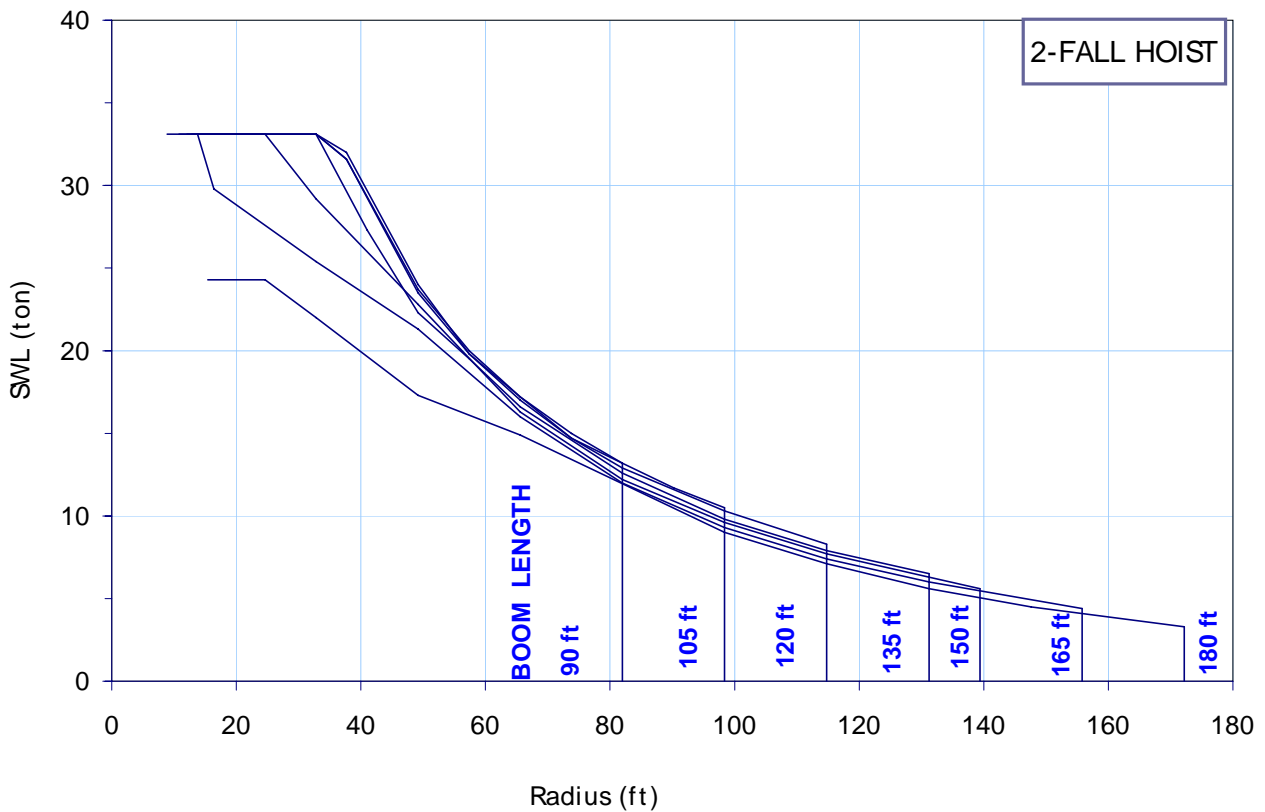
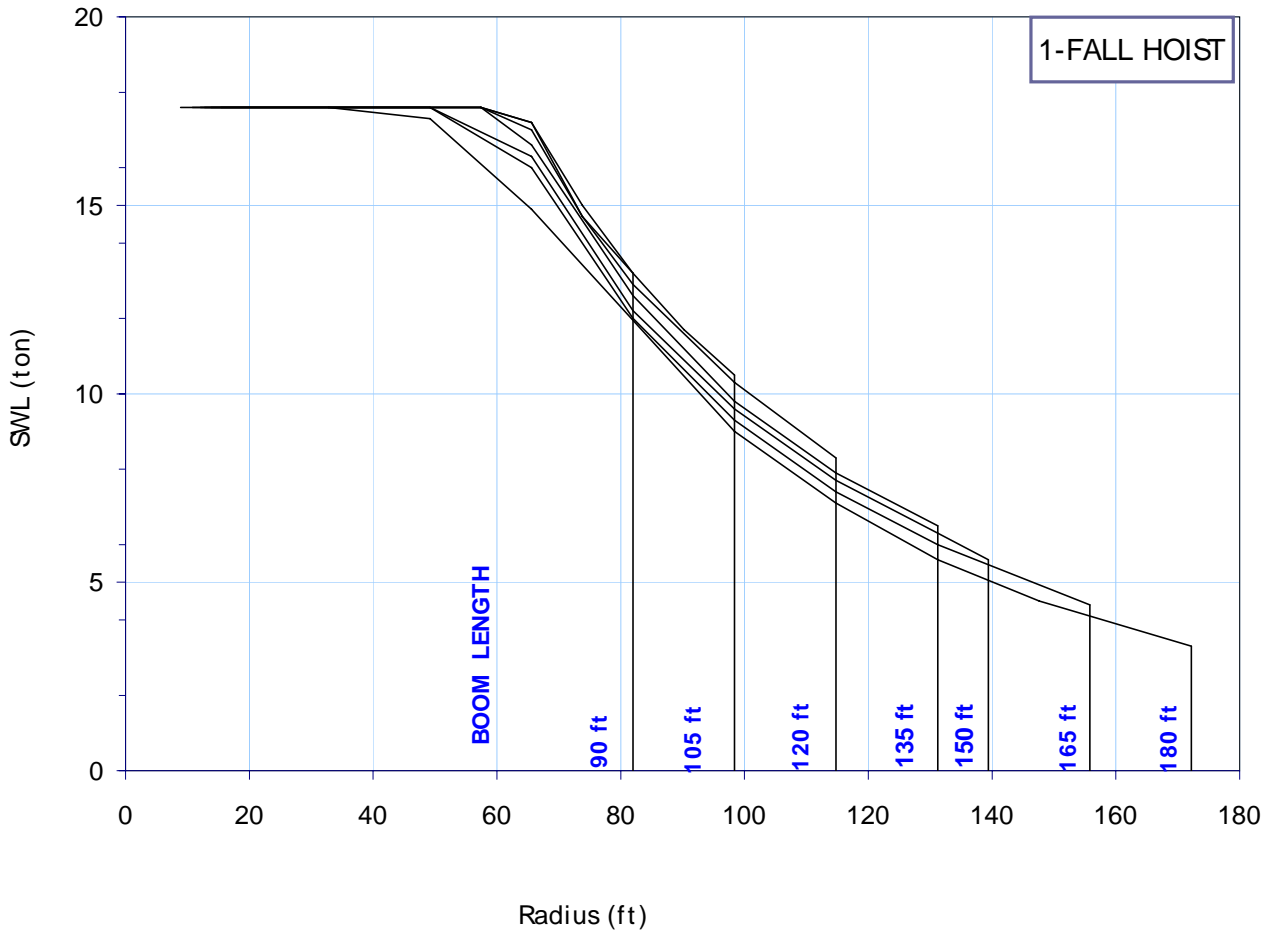

**M220D TYPICAL FOUNDATION & BUILDING REACTION  
(CRANE REEVED 1-FALL AT 180 ft BOOM LENGTH)**

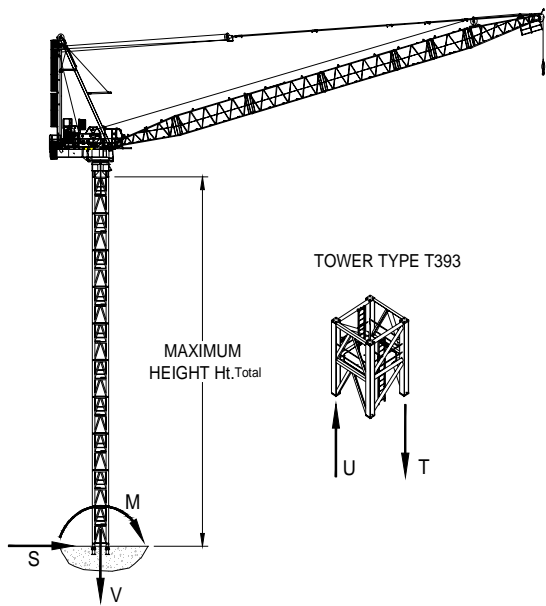

\*: IN SERVICE WIND = 45 mph

‡: OUT OF SERVICE WIND = 95 mph

**Notes:**

- 1 Structure is designed using permissible stress method.
- 2 These loads will vary by change of boom length, height and type of tower, actual site wind conditions, no of falls and change of wind speed.
- 3 To calculate alternative options for M220D refer to Favelle Favco Design Sheet named "Crane Weight Wind Chart".

**FREE STANDING BUILDING REACTION**

WITHOUT CLIMBING FRAME			
No. of Towers		15	
Design Load	Unit	I/ S*	O/ S‡
M	lb.ft	4,448,258	9,771,701
V	lb	341,713	304,235
S	lb	15,432	68,343
T	lb	544,536	1,082,459
U	lb	372,577	930,341
Ht <sub>Total</sub>	ft	197	
WITH EXTERNAL CLIMBING FRAME			
No. of Towers		14	
Design Load	Unit	I/ S*	O/ S‡
M	lb.ft	4,621,848	10,372,035
V	lb	330,690	291,007
S	lb	17,637	74,956
T	lb	559,968	1,141,983
U	lb	394,623	996,479
Ht <sub>Total</sub>	ft	184	
WITH INTERNAL CLIMBER			
No. of Towers		15	
Design Load	Unit	I/ S*	O/ S‡
M	lb.ft	4,448,258	9,771,701
V	lb	357,145	317,462
S	lb	15,432	68,343
T	lb	546,741	1,086,868
U	lb	370,373	928,137
Ht <sub>Total</sub>	ft	197	

**INTERNAL CLIMBER ON COLLARS**

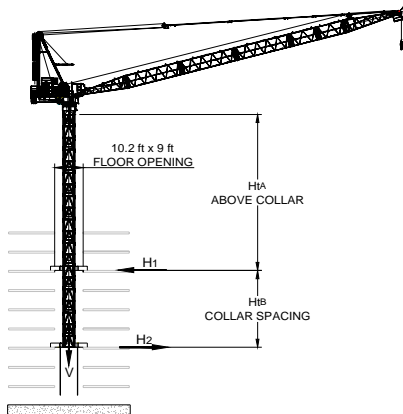

No. of Towers		15	
Design Load	Unit	I/ S*	O/ S‡
V	lb	357,145	317,462
H <sub>1</sub>	lb	116,844	253,529
H <sub>2</sub>	lb	101,412	185,186
Max Ht <sub>A</sub>	ft	157	
Min Ht <sub>B</sub>	ft	40	
Ht <sub>Total</sub>	ft	197	

**EXTRENAL CLIMBER + ONE TIE**

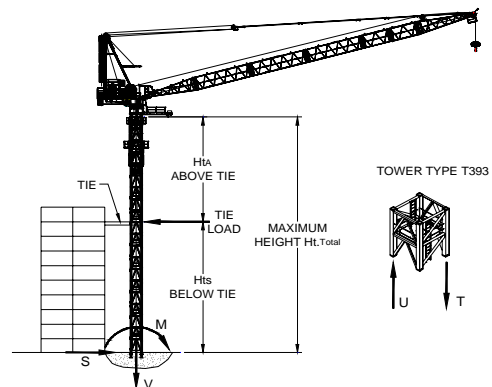

No. of Towers		23	
Design Load	Unit	I/ S*	O/ S‡
TIE	lb	66,138	213,850
M	lb.ft	2,169,882	4,520,587
V	lb	440,920	403,442
S	lb	44,092	83,775
T	lb	332,895	566,582
U	lb	112,435	365,964
Max Ht <sub>A</sub>	ft	164	
Max Ht <sub>B</sub>	ft	138	
Ht <sub>Total</sub>	ft	302	

**HOIST SPEED**

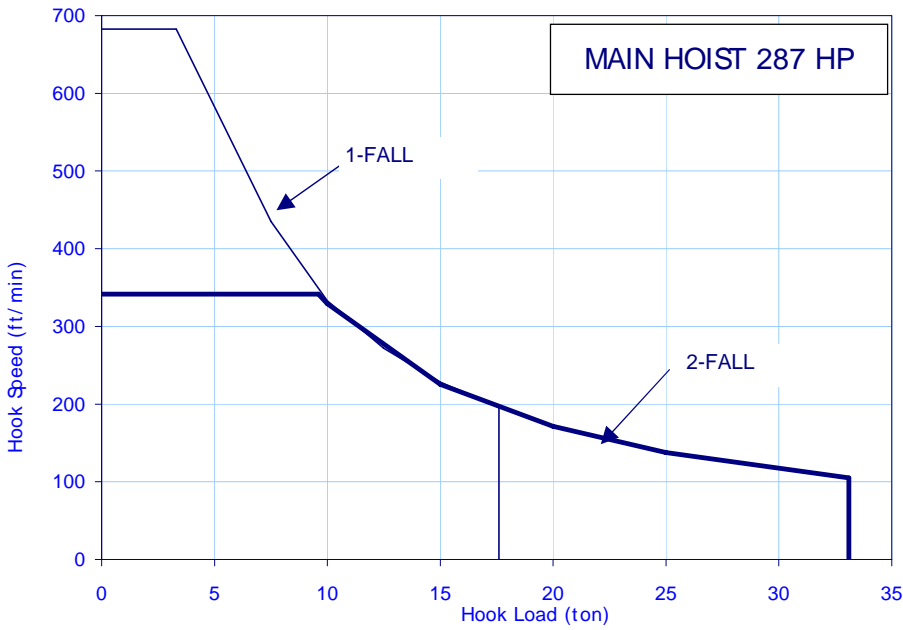

	LOAD (ton)	SPEED (ft/min)
1-FALL	3.3	683
	7.5	435
	10.0	333
	12.5	272
	15.0	228
2-FALL	17.6	196
	9.6	342
	10.0	329
	15.0	225
	20.0	172
	25.0	138
	33.1	105

**LUFF & SLEW SPEED**

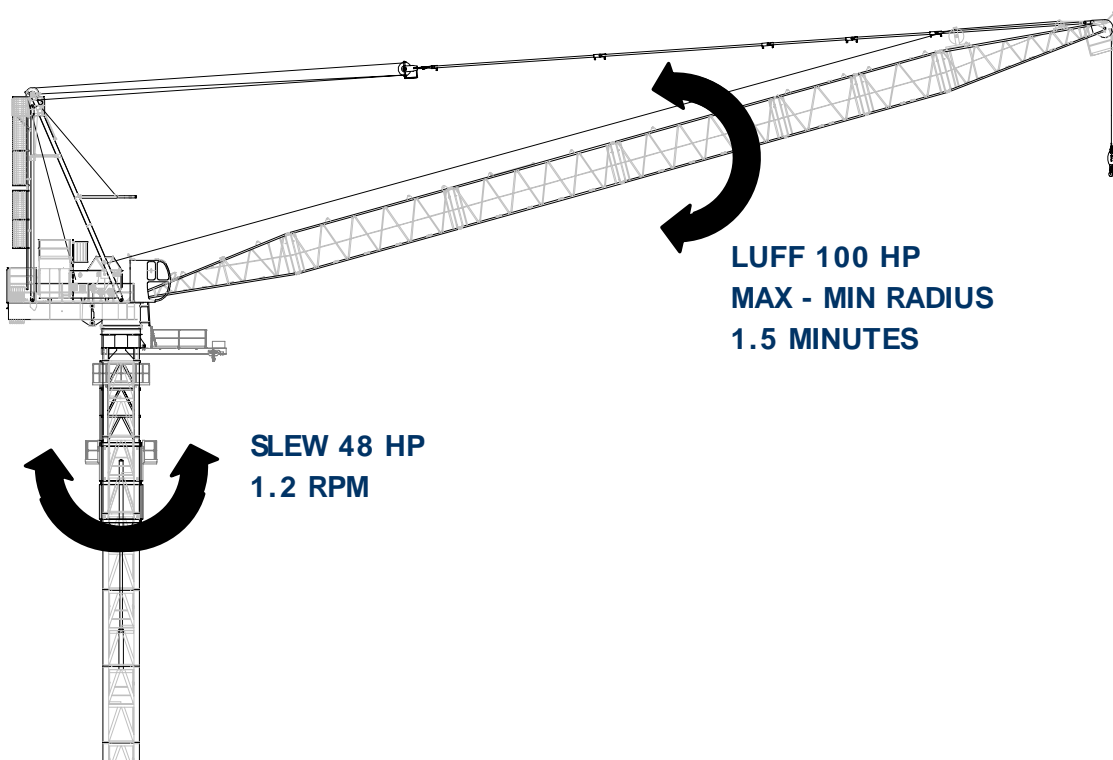

### TYPICAL CRANE ASSEMBLY

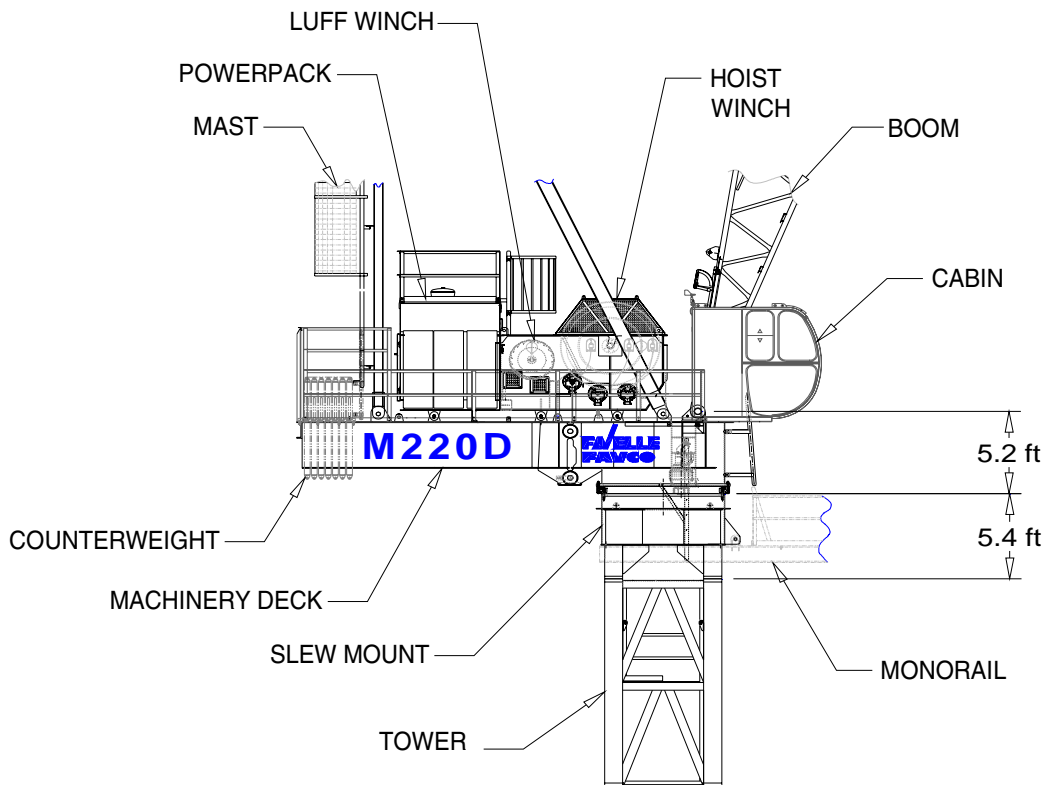

### EXTERNAL CLIMBING INSTALLATION CLEARANCE

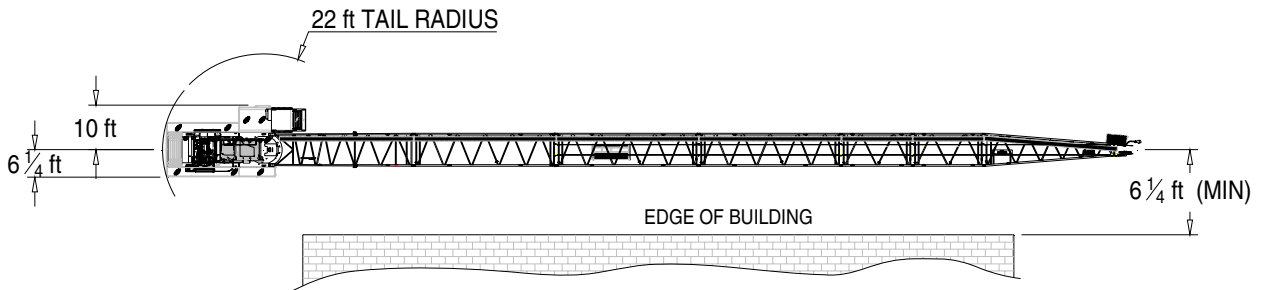

### OUT OF SERVICE CONFIGURATION





Boom Length (ft)	Minimum weathervaning*	
	Radius (ft)	Angle (°)
180	44	76.9
165	47	74.8
150	51	71.6
135	55	67.3
120	61	61.1
105	69	51.4
90	78	33.8

\*: Minimum weathervaning position is based on a wind speed of 45 mph or boom float at 56 mph.

# M220D TRANSPORTATION & ERECTION

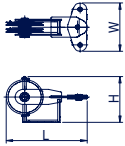
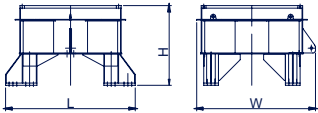

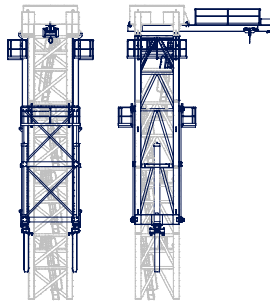
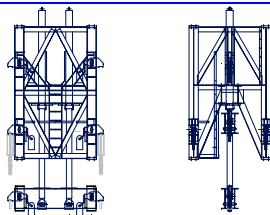
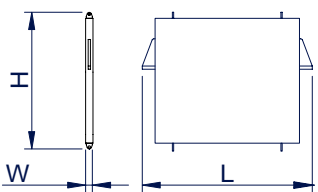
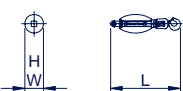
ITEM	QTY	DESCRIPTION		LENGTH L (feet)	HEIGHT H (feet)	WIDTH W (feet)	WEIGHT PER ITEM (ton)
1	1	SPLIT DECK-FRONT (INCL. SLEW DRIVE, PINS & HANDRAILS)		9.6	5.2	7.8	3.87
2	1	SPLIT DECK-REAR		15.7	5.0	7.8	3.93
3	1	POWERPACK (INCL. 850L OF OIL)		9.5	10.7	5.8	4.93
4	1	MAST FRONT LEG (INCL. MAST HEAD SHEAVES & PIN)		40.2	2.7	7.6	3.05
	2	MAST BACK LEG		33.8	1.0	0.5	0.46
	1	BOOM BUFFER		10.2	0.8	7.6	0.33
MAST ASSEMBLY (INC. SHEAVES, HEAD PIN, LADDERS, BUFFER AND PLATFORMS)							5.00
5	1	CABIN & PLATFORM ASSEMBLY		14.6	7.8	5.4	1.75
6	1	HOIST/LUFF WINCH ASSY (WITHOUT ROPE)		9.4	7.9	5.5	7.55
7	1	BOOM BOTTOM (INC. WALKWAY & PINS)		30.5	7.4	7.4	1.67
8	1	BOOM TOP ASSY (INC. ACCESSORIES)		31.6	7.4	7.4	2.27
9	1	BOOM EXTENSION 30.18 ft		30.5	8.0	7.4	1.77
10	1	BOOM EXTENSION 15.09 ft		15.5	8.0	7.4	1.04

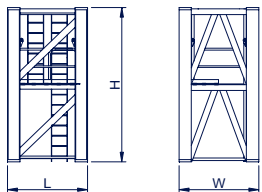
ITEM	QTY	DESCRIPTION	LENGTH L (feet)	HEIGHT H (feet)	WIDTH W (feet)	WEIGHT PER ITEM (ton)
11	1	BRIDLE	5.1	3.0	3.2	0.49
						
12	1	SLEW MOUNT (INCL. PLATFORMS)	8.8	5.4	8.1	3.36
						
	1	SLEW RING (INCL. BOLTS)	7.5	0.5	7.5	1.50
						
13	1	EXTERNAL CLIMBER ASSY	31.7	1.4	9.1	22.01
	2	CLIMBING CYLINDER	16.5	1.0	1.0	2.16
	2	SIDE PANEL	38.0	1.2	9.0	5.25
	2	FRAME TIE	23.0	0.6	11.2	0.89
	2	CLIMBING SUPPORT	8.7	1.1	2.6	0.46
	4	ACCESS PLATFORM	10.7	2.6	4.6	0.27
	1	MONORAIL	25.8	4.4	4.8	3.24
						
14	1	INTERNAL CLIMBER ASSY	10.5	15.0	7.9	11.62
	1	CLIMBING TOWER	10.5	13.1	7.9	8.40
	2	CYLINDER	12.2	0.8	0.8	0.69
	1	CLIMBING FOOT	10.5	2.5	1.8	1.84
						
15	7	COUNTERWEIGHT	7.7	6.6	0.3	3.15
						
16	1	16 TONNE SINGLE FALL HOOK	4.9	1.3	1.3	0.57
						
	1	32 TONNE 2-FALL HOOKBLOCK	5.9	1.2	3.4	0.64
						
17	1	TOWER SECTION T393	8.0	13.1	7.9	5.60
						
18	1	HOIST ROPE 32MM (~1-1/4 in, 3.36 lb / ft)	985.0	N/A	N/A	1.66
19	1	LUFF ROPE 24MM (1.66 lb / ft)	395.0	N/A	N/A	0.33