

TOWER CRANE

M440D

TECHNICAL DATA SHEET

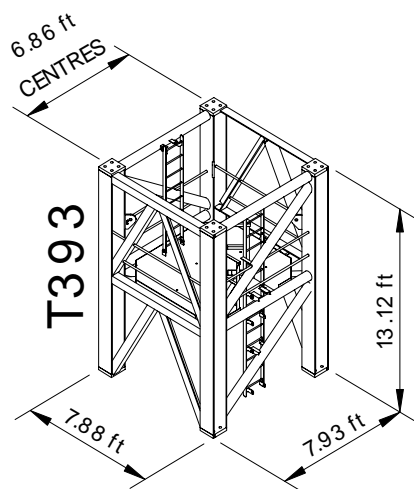

BOOM	LOAD @ RADIUS
105 ft	55.1 ton @ 43 ft 21.5 ton @ 98 ft
120 ft	55.1 ton @ 43 ft 17.7 ton @ 115 ft
135 ft	55.1 ton @ 43 ft 14.4 ton @ 131 ft
150 ft	55.1 ton @ 43 ft 12.9 ton @ 139 ft
165 ft	55.1 ton @ 39 ft 10.5 ton @ 156 ft
180 ft	48.5 ton @ 46 ft 8.8 ton @ 172 ft
195 ft	35.3 ton @ 33 ft 7.3 ton @ 180 ft
210 ft	35.3 ton @ 28 ft 5.3 ton @ 197 ft
225 ft	27.6 ton @ 38.7 ft 3.0 ton @ 213 ft

FAVELLE
FAVCO
www.favellefavco.com



1-FALL										
Boom Length (feet)	225	210	195	180	165	150	135	120	105	
Min Radius (feet)	20	17	16	14	14	13	12	11	10	
SWL at Min Radius (ton)	27.6	27.6	27.6	27.6	27.6	27.6	27.6	27.6	27.6	27.6
	20	27.6	27.6	27.6	27.6	27.6	27.6	27.6	27.6	27.6
	30	27.6	27.6	27.6	27.6	27.6	27.6	27.6	27.6	27.6
	40	27.2	27.6	27.6	27.6	27.6	27.6	27.6	27.6	27.6
	50	24.6	27.6	27.6	27.6	27.6	27.6	27.6	27.6	27.6
	60	22.6	26.6	27.6	27.6	27.6	27.6	27.6	27.6	27.6
	70	20.8	24.5	27.2	27.6	27.6	27.6	27.6	27.6	27.6
	80	19.3	22.5	24.5	26.1	26.3	26.9	27.2	27.4	27.6
	90	17.8	20.4	21.7	22.6	22.8	23.3	23.7	24.0	24.2
	100	16.3	18.3	18.9	19.6	19.8	20.3	20.6	21.0	-
	110	14.7	16.1	16.7	17.2	17.5	18.1	18.3	18.8	-
	120	13.1	14.2	14.8	15.2	15.6	16.1	16.3	-	-
	130	11.5	12.6	13.2	13.5	13.9	14.3	14.7	-	-
	140	10.1	11.2	11.8	12.1	12.5	-	-	-	-
	150	8.9	10.0	10.4	10.8	11.2	-	-	-	-
	160	8.0	8.9	9.3	9.8	-	-	-	-	-
	170	7.1	7.9	8.3	9.0	-	-	-	-	-
	180	6.1	7.0	-	-	-	-	-	-	-
190	5.3	6.0	-	-	-	-	-	-	-	
200	4.4	-	-	-	-	-	-	-	-	
210	3.3	-	-	-	-	-	-	-	-	
Max Radius (feet)	213	197	180	172	156	139	131	115	98	
SWL at Max Radius (ton)	3.0	5.3	7.3	8.8	10.5	12.9	14.4	17.7	21.5	

2-FALL										
Boom Length (feet)	225	210	195	180	165	150	135	120	105	
Min Radius (feet)	20	17	16	14	14	13	12	11	10	
SWL at Min Radius (ton)	27.6	35.3	35.3	48.5	55.1	55.1	55.1	55.1	55.1	55.1
	20	27.6	35.3	35.3	48.5	55.1	55.1	55.1	55.1	55.1
	30	27.6	34.7	35.3	48.5	55.1	55.1	55.1	55.1	55.1
	40	27.2	31.6	34.2	48.5	54.5	55.1	55.1	55.1	55.1
	50	24.6	28.8	32.6	44.6	45.7	46.0	46.5	47.1	47.3
	60	22.6	26.6	29.9	37.1	37.7	38.1	38.4	38.7	39.1
	70	20.8	24.5	27.2	30.8	31.2	31.6	31.8	31.9	32.4
	80	19.3	22.5	24.5	26.1	26.3	26.9	27.2	27.4	27.6
	90	17.8	20.4	21.7	22.6	22.8	23.3	23.7	24.0	24.2
	100	16.3	18.3	18.9	19.6	19.8	20.3	20.6	21.0	-
	110	14.7	16.1	16.7	17.2	17.5	18.1	18.3	18.8	-
	120	13.1	14.2	14.8	15.2	15.6	16.1	16.3	-	-
	130	11.5	12.6	13.2	13.5	13.9	14.3	14.7	-	-
	140	10.1	11.2	11.8	12.1	12.5	-	-	-	-
	150	8.9	10.0	10.4	10.8	11.2	-	-	-	-
	160	8.0	8.9	9.3	9.8	-	-	-	-	-
	170	7.1	7.9	8.3	9.0	-	-	-	-	-
	180	6.1	7.0	-	-	-	-	-	-	-
190	5.3	6.0	-	-	-	-	-	-	-	
200	4.4	-	-	-	-	-	-	-	-	
210	3.3	-	-	-	-	-	-	-	-	
Max Radius (feet)	213	197	180	172	156	139	131	115	98	
SWL at Max Radius (ton)	3.0	5.3	7.3	8.8	10.5	12.9	14.4	17.7	21.5	

Note: All charts are for information only and should not be used for lifting purposes. Favelle Favco reserves the right to make specification changes without prior notice.



1-FALL									
Boom Length (feet)	225	210	195	180	165	150	135	120	105
Min Radius (feet)	25	22	21	19	19	18	17	16	15
SWL at Min Radius (ton)	11.0	11.0	11.0	11.0	11.0	11.0	11.0	11.0	11.0
30	11.0	11.0	11.0	11.0	11.0	11.0	11.0	11.0	11.0
40	11.0	11.0	11.0	11.0	11.0	11.0	11.0	11.0	11.0
50	11.0	11.0	11.0	11.0	11.0	11.0	11.0	11.0	11.0
60	11.0	11.0	11.0	11.0	11.0	11.0	11.0	11.0	11.0
70	11.0	11.0	11.0	11.0	11.0	11.0	11.0	11.0	11.0
80	11.0	11.0	11.0	11.0	11.0	11.0	11.0	11.0	11.0
90	11.0	11.0	11.0	11.0	11.0	11.0	11.0	11.0	11.0
100	11.0	11.0	11.0	11.0	11.0	11.0	11.0	11.0	11.0
110	11.0	11.0	11.0	11.0	11.0	11.0	11.0	11.0	-
120	11.0	11.0	11.0	11.0	11.0	11.0	11.0	11.0	-
130	11.0	11.0	11.0	11.0	11.0	11.0	11.0	-	-
140	10.9	10.9	10.9	11.0	11.0	11.0	11.0	-	-
150	9.9	10.1	10.2	10.6	10.7	-	-	-	-
160	8.8	9.2	9.3	10.0	10.2	-	-	-	-
170	7.9	8.3	8.3	9.0	-	-	-	-	-
180	7.0	7.4	7.4	7.9	-	-	-	-	-
190	6.2	6.6	6.6	-	-	-	-	-	-
200	5.5	5.7	-	-	-	-	-	-	-
210	4.7	-	-	-	-	-	-	-	-
220	3.6	-	-	-	-	-	-	-	-
Max Radius (feet)	223	206	190	182	165	149	141	124	108
SWL at Max Radius (ton)	3.3	5.2	6.6	7.7	9.6	11.0	11.0	11.0	11.0

Note: All charts are for information only and should not be used for lifting purposes. Favelle Favco reserves the right to make specification changes without prior notice.

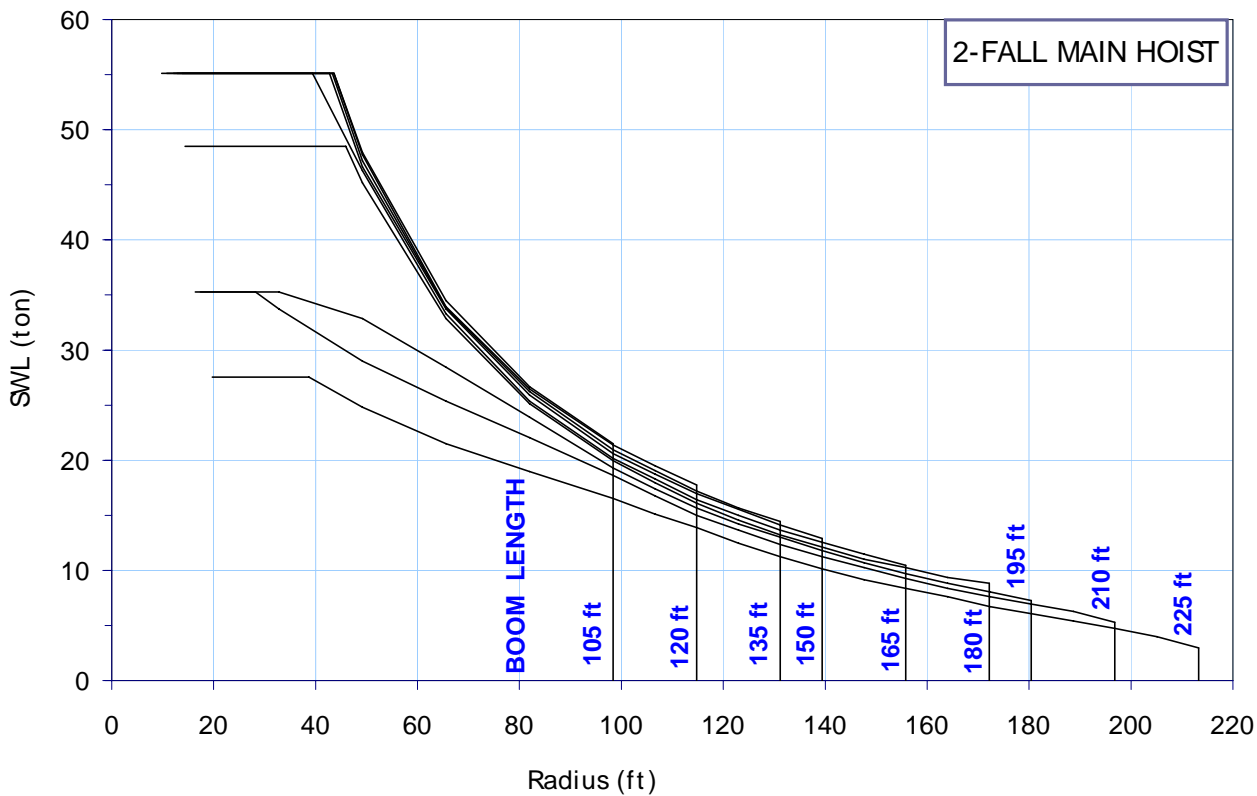
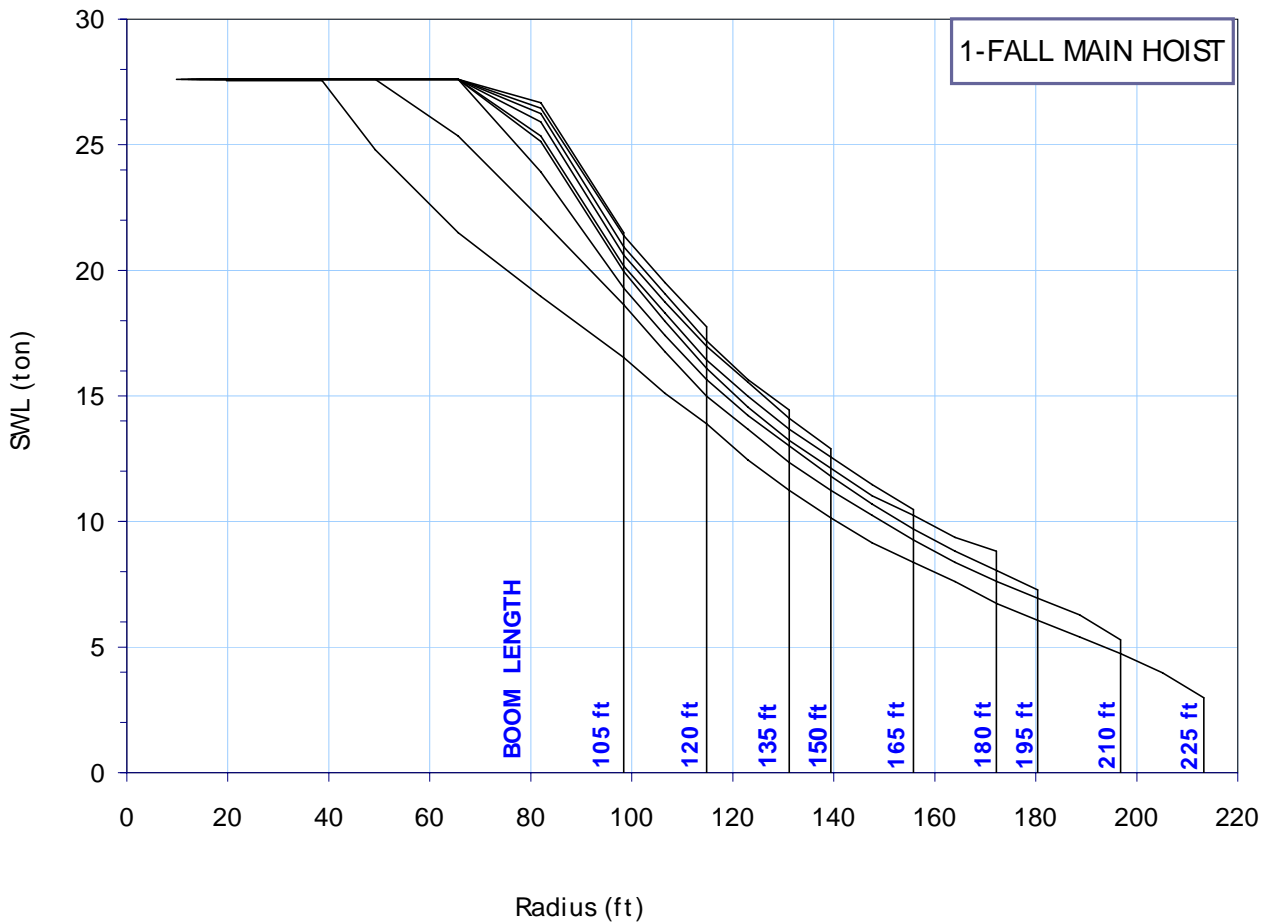

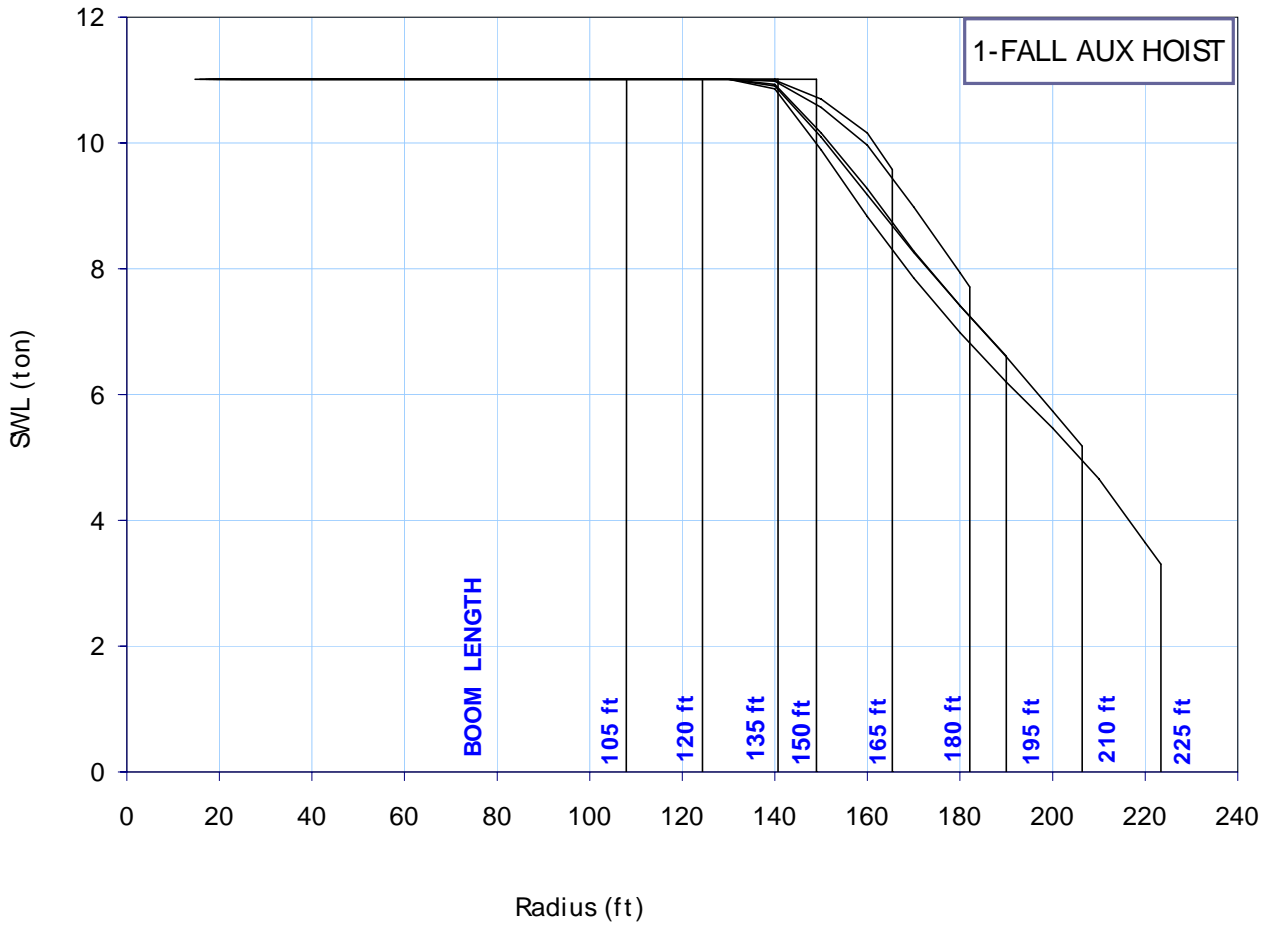

**M440D TYPICAL FOUNDATION & BUILDING REACTION
(CRANE REEVED 2-FALLS AT 165 ft BOOM LENGTH)**

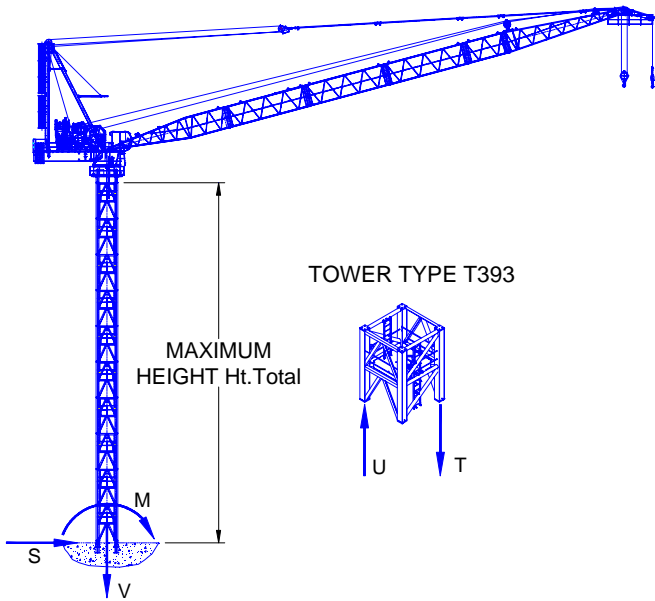

*: IN SERVICE WIND = 45 mph

‡: OUT OF SERVICE WIND = 95 mph

Notes:

- 1 Structure is designed using permissible stress method.
- 2 These loads will vary by change of boom length, height and type of tower, actual site wind conditions, no of falls and change of wind speed.
- 3 To calculate alternative options for M440D refer to Favelle Favco Design Sheet named "Crane Weight Wind Chart".

FREE STANDING BUILDING REACTION

WITHOUT CLIMBING FRAME

No. of Towers		12	
Design Load	Unit	I/ S*	O/ S‡
M	lb.ft	5,938,243	7,630,751
V	lb	478,398	381,396
S	lb	15,432	66,138
T	lb	731,927	881,840
U	lb	493,830	692,244
Ht _{Total}	ft	157	

WITH EXTERNAL CLIMBING FRAME

No. of Towers		11	
Design Load	Unit	I/ S*	O/ S‡
M	lb.ft	6,314,356	7,659,683
V	lb	487,221	368,172
S	lb	17,637	74,957
T	lb	767,208	881,848
U	lb	535,723	696,660
Ht _{Total}	ft	144	

WITH INTERNAL CLIMBER

No. of Towers		12	
Design Load	Unit	I/ S*	O/ S‡
M	lb.ft	6,242,027	4,166,173
V	lb	491,630	396,832
S	lb	15,432	46,297
T	lb	767,208	529,109
U	lb	520,290	330,693
Ht _{Total}	ft	157	

INTERNAL CLIMBER ON COLLARS

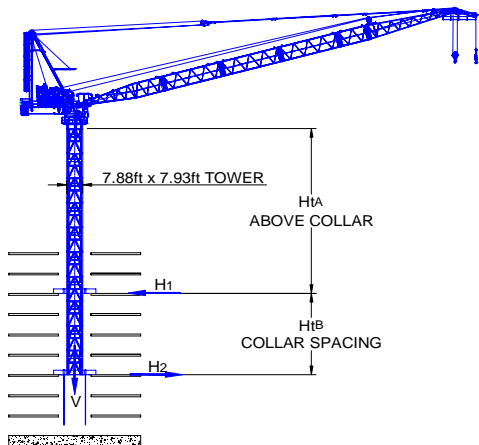

No. of Towers		12	
Design Load	Unit	I/ S*	O/ S‡
V	lb	478,398	381,396
H ₁	lb	185,186	238,097
H ₂	lb	169,754	171,959
Max Ht _A	ft	125	
Min Ht _B	ft	31	
Ht _{Total}	ft	157	

EXTRENAL CLIMBER + ONE TIE

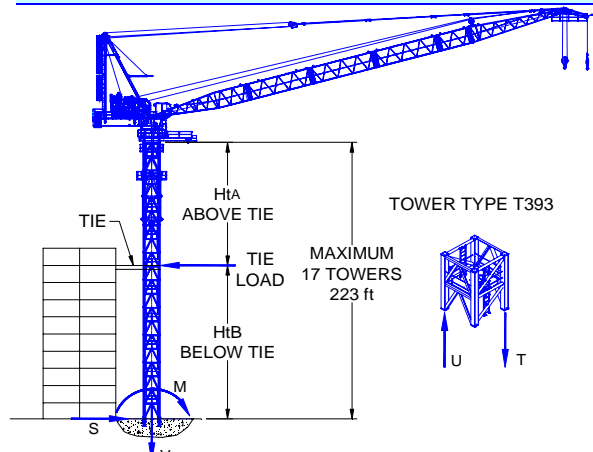

No. of Towers		17	
Design Load	Unit	I/ S*	O/ S‡
TIE	lb	103,616	178,573
M	lb.ft	2,835,304	3,254,813
V	lb	559,968	465,171
S	lb	83,775	88,184
T	lb	432,102	451,943
U	lb	152,117	220,460
Max Ht _A	ft	125	
Max Ht _B	ft	98	
Ht _{Total}	ft	223	

HOIST SPEED

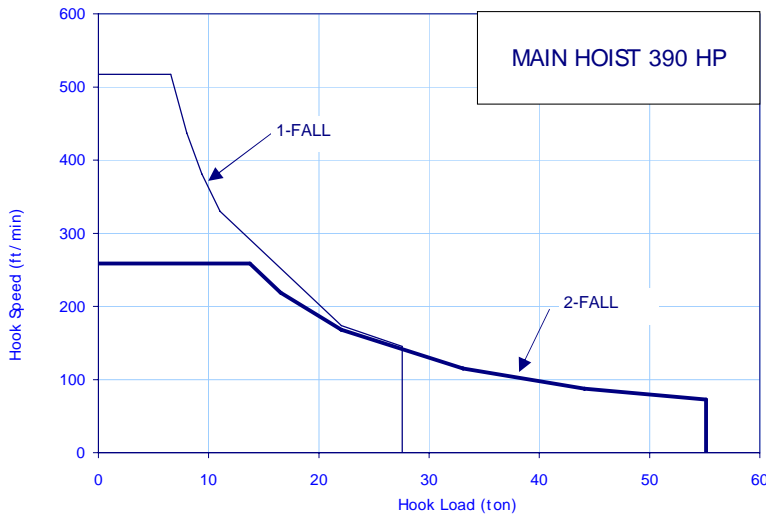

	LOAD (ton)	SPEED (ft/min)
1-FALL	6.6	517
	8.0	437
	9.4	381
	11.0	330
	22.0	174
2-FALL	27.6	145
	13.7	259
	16.5	219
	22.0	168
	33.1	115
	44.1	87
	55.1	73

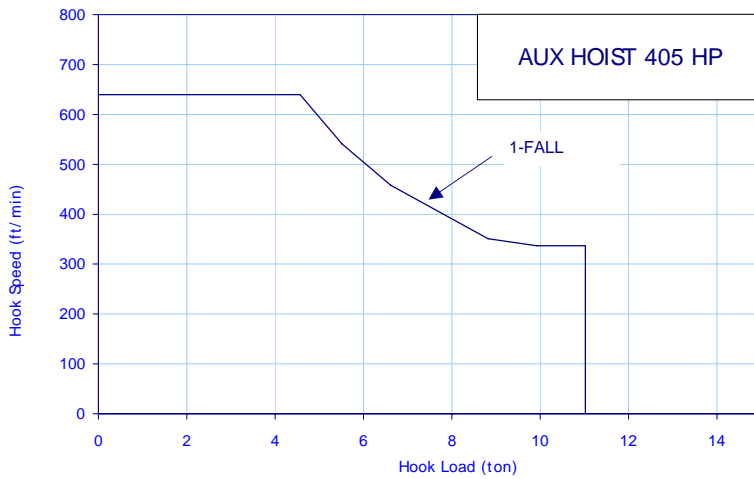

	LOAD (ton)	SPEED (ft/min)
1-FALL	4.6	640
	5.5	541
	6.6	458
	8.8	351
	9.9	337
	11.0	337

LUFF & SLEW SPEED

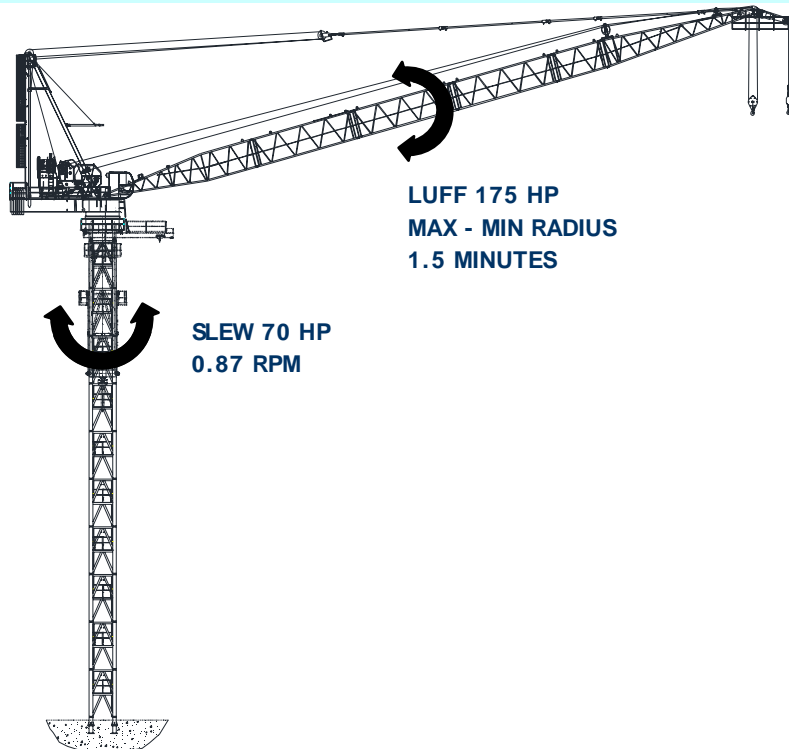

TYPICAL CRANE ASSEMBLY

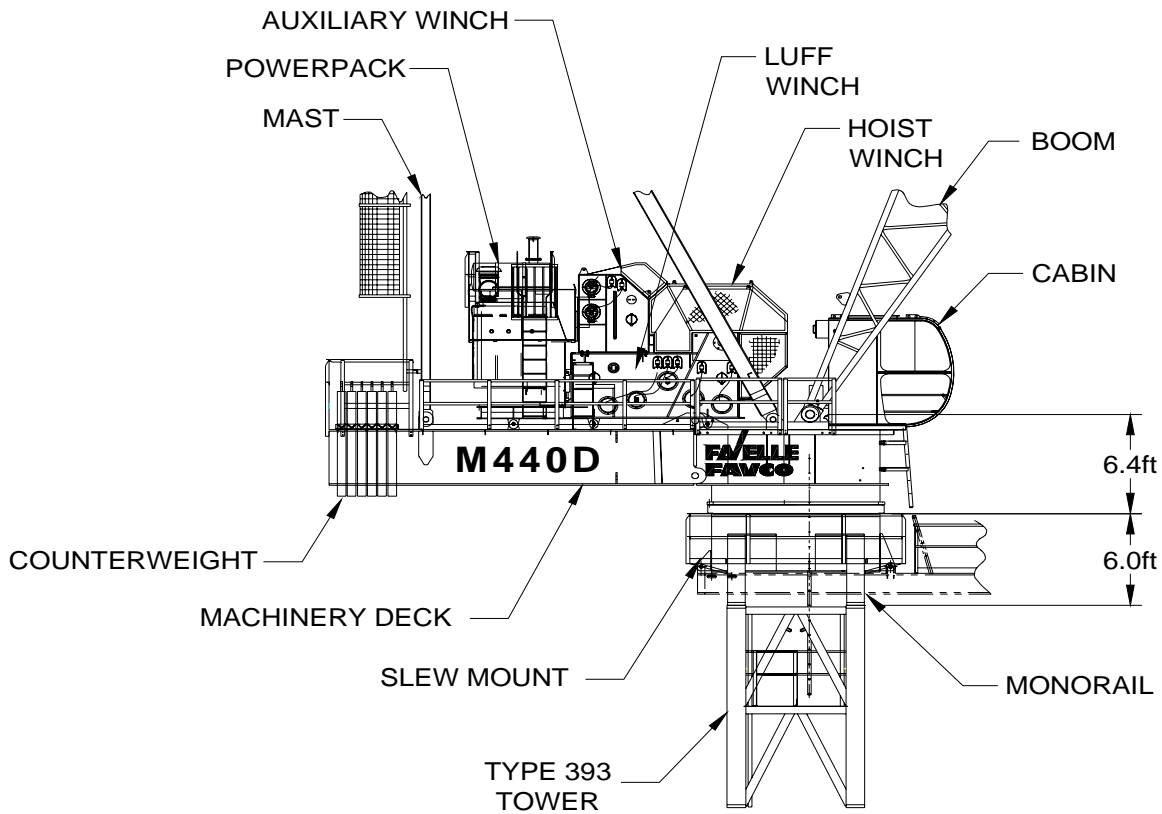

EXTERNAL CLIMBING INSTALLATION CLEARANCE

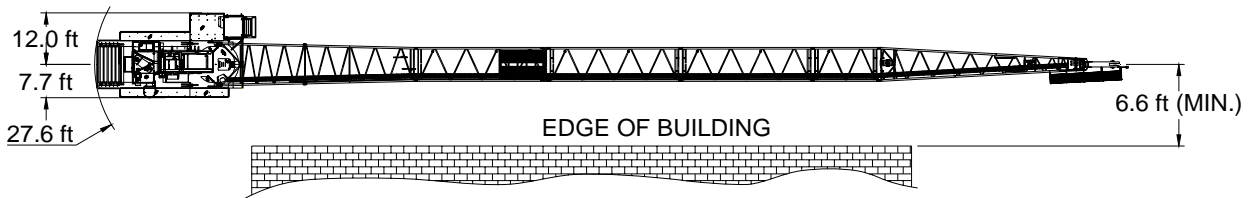

OUT OF SERVICE CONFIGURATION

Boom Length (ft)	Minimum weathervaning*	
	Radius (ft)	Angle (°)
225	41	80.1
210	43	78.7
195	46	76.9
180	50	74.7
165	53	71.9
150	58	68.2
135	63	63.2
120	69	56.0
105	76	44.7

*: Minimum weathervaning position is based on a wind speed of 45 mph.

M440D TRANSPORTATION & ERECTION



ITEM	QTY	DESCRIPTION		LENGTH L (feet)	HEIGHT H (feet)	WIDTH W (feet)	WEIGHT PER ITEM (ton)
1	1	SPLIT DECK-FRONT (INCL. SLEW DRIVE, PINS & HANDRAILS)		11.8	6.5	11.0	7.50
2	1	SPLIT DECK-REAR		21.8	4.7	11.0	8.27
3	1	POWERPACK (INCL. 850L OF OIL)		10.4	11.8	7.2	5.57
4	1	MAST FRONT LEG (INCL. MAST HEAD SHEAVES & PIN)		42.2	1.6	1.1	1.38
	2	MAST BACK LEG		38.3	0.5	1.1	0.55
	1	BOOM BUFFER		12.0	0.8	9.2	0.20
MAST ASSEMBLY (INC. SHEAVES, HEAD PIN, LADDERS, BUFFER AND PLATFORMS)							6.65
5	1	CABIN & PLATFORM ASSEMBLY		14.9	7.8	5.4	1.57
6	1	HOIST/LUFF WINCH ASSY (WITHOUT ROPE)		12.9	9.6	6.0	12.02
7	1	FLY WINCH ASSEMBLY (EMPTY DRUM)		5.2	5.8	4.7	3.20
8	1	BOOM BOTTOM (INC. WALKWAY & PINS)		45.6	8.6	7.9	2.53
9	1	BOOM TOP ASSY (WITH FLY) (INC. ACCESSORIES)		55.1	7.9	10.0	5.15
10	1	BOOM EXTENSION 30.18 ft		30.6	8.6	7.9	1.96

ITEM	QTY	DESCRIPTION	LENGTH L (feet)	HEIGHT H (feet)	WIDTH W (feet)	WEIGHT PER ITEM (ton)		
11	1	BOOM EXTENSION 15.09 ft			15.5	8.6	7.9	1.12
12	1	BRIDLE			5.2	3.3	3.8	0.61
13	1	SLEW MOUNT (INCL. PLATFORMS)			11.2	10.9	5.9	5.63
	1	SLEW RING (INCL. BOLTS)			10.2	0.6	10.2	1.93
14	1	EXTERNAL CLIMBER ASSY			32.0	1.0	10.2	23.00
	2	CLIMBING CYLINDER			16.5	1.0	1.0	2.16
	2	SIDE PANEL			37.8	1.2	9.0	5.48
	2	FRAME TIE			23.0	0.6	11.2	1.00
	2	CLIMBING SUPPORT			8.7	1.1	2.6	0.37
	4	ACCESS PLATFORM			11.5	3.5	4.1	0.22
	1	MONORAIL			24.4	5.5	4.6	3.24
15	1	INTERNAL CLIMBER ASSY			10.5	15.6	7.9	11.62
	1	CLIMBING TOWER			10.5	13.1	7.9	8.40
	2	CYLINDER			12.2	0.8	0.8	0.69
	1	CLIMBING FOOT			10.5	2.5	1.8	1.84
16	6	COUNTERWEIGHT			9.6	7.4	0.5	7.2
17	1	10 TONNE SINGLE FALL HOOK BLOCK			8.1	1.3	1.3	0.31
	1	25 TONNE SINGLE FALL HOOK BLOCK			12.5	1.3	1.3	0.99
18	1	TOWER SECTION T393			8.0	13.1	7.9	5.39
19	1	HOIST ROPE 42MM (~1-5/8 in, 5.75 lb / ft)			985.0	N/A	N/A	2.83
20	1	FLY ROPE 24MM (1.89 lb / ft)			492.0	N/A	N/A	0.46
21	1	LUFF ROPE 24MM (1.83 lb / ft)			395.0	N/A	N/A	0.36