

GEHL®

RS5-19

TELESCOPIC HANDLER



CAPACITIES

Lift Capacity (kg)	5,500 lbs. (2495)
Maximum Lift Height (m)	19'1" (5.8)
Capacity at Maximum Lift Height (kg)	3,000 lbs. (1361)
Maximum Forward Reach (m)	11'0" (3.4)
Capacity at Max. Forward Reach (kg)	1,850 lbs. (840)
Max. Reach Below Grade (mm)	0" (0)

GENERAL SPECIFICATIONS

Approximate Weight (kg)	10,000 lbs. (4536)
Length – Less Forks (m)	12'4" (3.8)
Width (m)	5'11" (1.8)
Ground Clearance (mm)	14" (350)
Wheelbase (m)	7'6" (2.29)
Turning Radius (m)	11'0" (3.35)
Overall Height (m)	6'4" (1.93)
Frame Leveling	N/A
Fuel Capacity (L)	17 gal. (64)

TIRE OPTIONS

- 12.00 x 16.5 Bias/10 PR
- 12.00 x 16.5 Bias/10 PR Foam-Filled
- 12.00 x 16.5 Solid Rubber

ENGINE

Manufacturer	Yanmar
Power (kW)	69 hp (50.1)
Aspiration	Natural
Model	4TNV98C Tier IV
Rated Speed	2500 rpm

COMPONENTS

Transmission	Rexroth 2-speed
Maximum Travel Speed (km/hr)	15 mph (24)
Selective Steering	4-Wheel
	2-Wheel
	Crab
Hydraulically Actuated Internal Wet-Disc Brakes	2-Wheel
Parking Brake	Spring-Applied, Hydraulic Release (SAHR) on Front
	Axle
Axle Manufacturer	Dana

HYDRAULIC SYSTEM

Pump Type	Gear
Total Capacity (L/min)	20 gpm (76)
System Pressure (bar)	3350 psi (231)
Hydraulic Reservoir Capacity (L)	18 gal. (68)

RS5-19

TELESCOPIC HANDLER

FEATURES

- Boom Control Joystick
- 5,500 lbs. (2495 kg) Capacity
- Fork Tilt Joystick
- 3,000 lbs. (1361 kg) Capacity at Full Lift Height
- SAHR Parking Brake
- Maximum Lift Height - 19 ft. 1 in. (5.8 m)
- Reverse Warning Horn
- 2 Speed Forward/Reverse Hydrostatic Drive
- Engine Temperature, Fuel, and Hourmeter Gauges
- Planetary Axles (Limited Slip Front Differential)
- Right Hand Side Mounted Rear View Mirror
- Full Time Four Wheel Drive
- Engine Block Heater
- Two Wheel Wet Disc Brakes
- Inline Glow Plug Cold Weather Start
- Power Steering
- Left Hand Front Fender
- Selective Steering (Front Wheel, All Wheel, and Crab)
- 12-Volt Electric System
- Storage Compartment Under Seat
- DYNATTACH® Quick Carriage Release
- Dual Element Air Filter with Restriction Indicator
- Automatic Self-Leveling Fork System

LOAD CHART

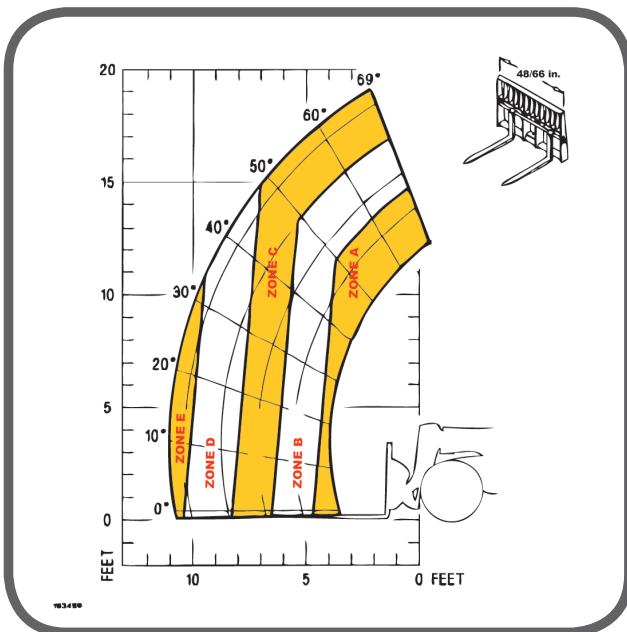

- A** 5,500 lbs. (2495 kg)
- B** 4,000 lbs. (1815 kg)
- C** 3,000 lbs. (1361 kg)
- D** 2,000 lbs. (908 kg)
- E** 1,850 lbs. (840 kg)



GEHL
gehl.com

West Bend, WI 53095 U.S.A.
Tel: 262-334-9461
Fax: 262-338-7517



For more information on Gehl equipment, call our hotline at
1-800-628-0491
or visit gehl.com

Gehl reminds users to read and understand the operator's manual before operating any equipment. Also, make sure all safety devices and shields are in place and functioning properly.

Gehl reserves the right to add improvements or make changes in features and specifications at any time without notice or obligation.