

# MULTI-TALENTED, VERSATILE PARTNERS

GENIE® GTH™ RANGE



**Genie**®  
A TEREX BRAND

TAKING YOU **HIGHER**™  
GENIELIFT.COM

*Courtesy of Crane.Market*

# TANGIBLE BENEFITS

## MULTI-TALENTED, VERSATILE PARTNERS **GENIE® GTH™ RANGE SPECIFICATIONS**

MODEL	MAX. LIFTING CAPACITY		MAX. LIFTING HEIGHT		MAX. FORWARD REACH		WEIGHT*		ENGINE
	METRIC	IMPERIAL	METRIC	IMPERIAL	METRIC	IMPERIAL	METRIC	IMPERIAL	
<b>Compact</b>									
GTH™-2506	2,500 kg	5,511 lbs	5.79 m	19 ft	3.35 m	10 ft 12 in	4,480 kg	10,097 lbs	Deutz Diesel 55.4 kW (74 HP)**
GTH™-3007	3,000 kg	6,614 lbs	6.89 m	22 ft 7 in	3.99 m	13 ft	5,970 kg	13,007 lbs	Deutz Diesel 55.4 kW (74 HP)**

### Focus on GTH-2506

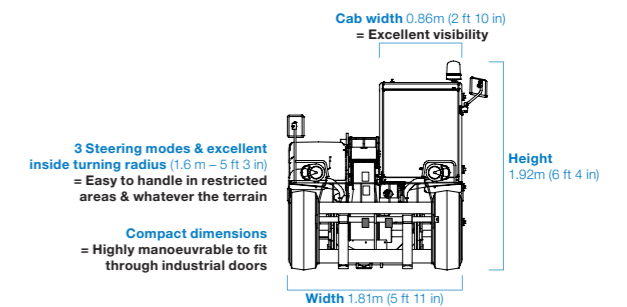
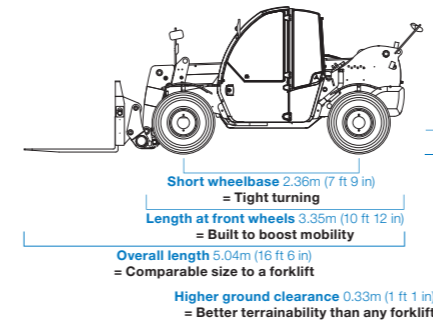

MODEL	MAX. LIFTING CAPACITY		MAX. LIFTING HEIGHT		MAX. FORWARD REACH		WEIGHT*		ENGINE
	METRIC	IMPERIAL	METRIC	IMPERIAL	METRIC	IMPERIAL	METRIC	IMPERIAL	
<b>High Reach</b>									
GTH™-4014	4,000 kg	8,818 lbs	13.57 m	44 ft 6 in	9.08 m	29 ft 9 in	10,140 kg	22,355 lbs	Perkins TD 74 kW (99 HP)**
GTH™-4018	4,000 kg	8,818 lbs	17.61 m	57 ft 9 in	13.36 m	43 ft 10 in	11,980 kg	26,411 lbs	Perkins TD 74 kW (99 HP)**

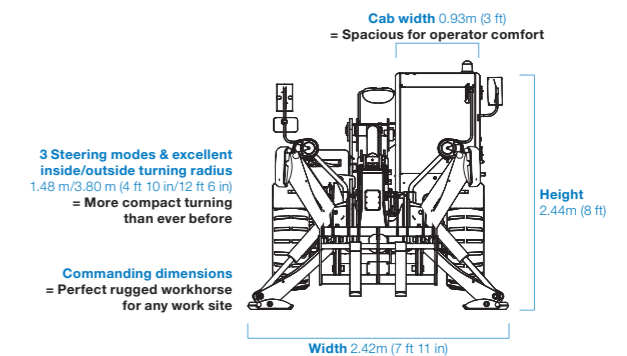
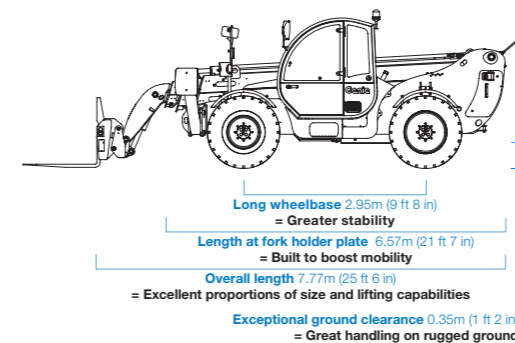

MODEL	MAX. LIFTING CAPACITY		MAX. LIFTING HEIGHT		MAX. FORWARD REACH		WEIGHT*		ENGINE
	METRIC	IMPERIAL	METRIC	IMPERIAL	METRIC	IMPERIAL	METRIC	IMPERIAL	
<b>Rotating</b>									
GTH™-4016 R	4,000 kg	8,818 lbs	15.42 m	50 ft 6 in	13.35 m	43 ft 10 in	12,900 kg	28,445 lbs	Perkins TD 74 kW (99 HP)***
GTH™-4018 R	4,000 kg	8,818 lbs	17.54 m	57 ft 5 in	15.53 m	50 ft 1 in	14,000 kg	30,870 lbs	Perkins TD 74 kW (99 HP)***
GTH™-5021 R	5,000 kg	11,022 lbs	20.86 m	68 ft	18.24 m	59 ft 8 in	17,180 kg	37,876 lbs	Perkins TD 83 kW***

### Focus on GTH-5021R

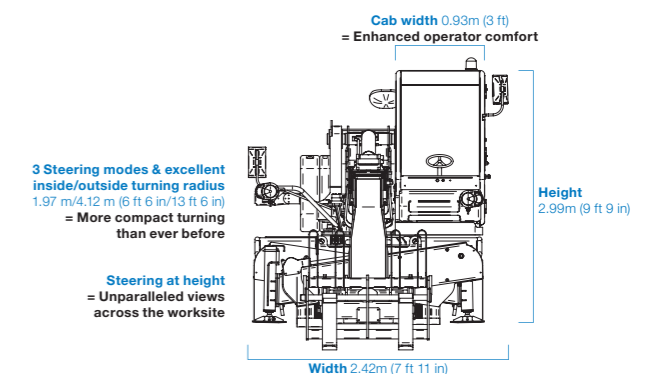
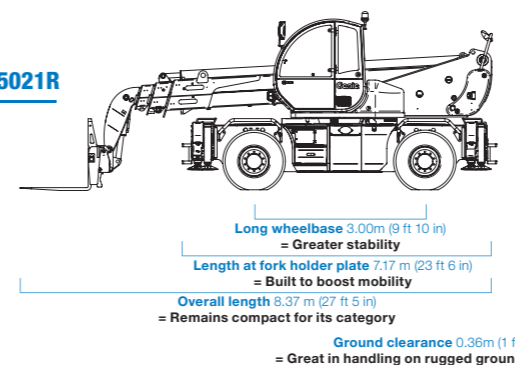

### IMPROVE PERFORMANCE

Seven completely redesigned machines featuring updated engines, improved serviceability, more interchangeable components and accessories, and enhanced lifting and loading capabilities.

### REDUCE COSTS

Innovative solutions and hardwearing components are continuously explored to increase your return on investment and reduce your cost of ownership.

### RAISE PROFITABILITY

Common components and accessories across the entire telehandler range reduce storage space and operator and technical training costs, to save you time and money.

### INCREASE PRODUCTIVITY

Providing the wide field of vision and comfort operators need to work safely and focus on the job, the spacious cab includes new ergonomics and new optional and standard features.

**Stringent testing, proven performance**  
 Genie telehandlers have undergone rigorous life cycle testing - to help ensure that they perform as expected on some of the most demanding job sites.

\* Weight will vary depending on options and/or country standards. \*\* Stage IIIA engine & Stage IIIB engine. \*\*\* Stage IIIB engine.



If you are a construction professional, you need telehandlers that are reliable, durable and versatile. If you are a rental company, you rely on machines that provide good returns and offer the right combination of **Compact, High-Reach** and **Rotating** performance to meet virtually any requirement. With our three telehandler product families, you will find the right solution, whatever your business.

**Industry-leading engine**

Like all Genie products, Genie telehandlers, are known for being service-friendly. Equipped with simplified and powerful Stage IIIB engines (Stage IIIA on demand), maintenance and troubleshooting are fast and easy. Engine covers open at just the right angle, and the valve bank, fuel tank, radiator, filters and greasing points are all positioned within easy reach. Hydraulic boom greasing points are also very simple to access.



**GREAT PERFORMANCE  
IN A SMALL PACKAGE**

Whether you need to work indoors or out, Genie Compact telehandlers are easy to manoeuvre in confined and crowded environments while offering the ability to lift, move and place heavy loads without compromising on power. Utilizing intuitive controls and features designed with the user in mind, these machines are easy to operate, fast and simple to service, and come equipped with the latest low-emissions 74hp Deutz Stage IIIB (Tier IV Final) compliant engines.

- Easy to transport, lightweight and compact.
- Excellent manoeuvrability in confined spaces.
- Great ground clearance for outdoor applications.
- Hydrostatic transmission for smooth, high precision positioning.
- Multi-purpose capabilities with interchangeable attachments.
- Double brake discs for responsive braking efficiency.



**GTH™-2506 & GTH™-3007  
Genie® Compact Telehandlers'**  
applications include:

- ▶ Construction
- ▶ Refurbishment
- ▶ Masonry
- ▶ Landscaping
- ▶ Recycling

**WHEN ENDURANCE AND VERSATILITY  
ARE PARAMOUNT**

Designed to offer excellent return on investment and increase your uptime, Genie High Reach telehandlers are true workhorses. Providing load capacities up to 4000 kg (8,818 lbs), lifting heights up to 17.61 m (58 ft) and available with a wide choice of attachments, these models are well-suited to particularly challenging work site demands.

- Ideal for tough jobs that demand reliable, high endurance capabilities.
- Superior handling performance and precise positioning.
- Hydrostatic transmission and new gearbox offer high torque and high traction speeds.
- Long reach, a class leading outside turning radius and overall machine width come with excellent drivability, to allow operators to perform tasks up to six floors high, even in congested and confined spaces.

**GTH™-4014 & GTH™-4018  
Genie® High Reach Telehandlers'**  
applications include:

- ▶ Construction
- ▶ Refurbishment
- ▶ Industrial
- ▶ Road and tunnel building
- ▶ Bridge construction



**ROTATION HAS NEVER  
BEEN SO SIMPLE**

Built to take on challenging tasks where precise positioning, high capacity and outreach are required, Genie Rotating telehandlers provide the ability to raise heavy loads with or without stabilizers, and access places where large cranes cannot go.

- Combination of superior lifting height, high-precision positioning, extra high capacity, ease of operation and simple maintenance.
- A versatility-driven design and wide choice of easily interchangeable attachments, (e.g. jib, hoists, man platform) make one machine suitable to handle an extremely wide variety of applications.
- A 400° rotating turret makes positioning simple, and precise.
- Designed to raise heavy loads with or without stabilizers.

**GTH™-4016R, GTH™-4018R &  
GTH™-5021R Genie® Rotating  
Telehandlers'** applications include:

- ▶ Construction
- ▶ Refurbishment
- ▶ Steelwork
- ▶ Industrial
- ▶ Road and tunnel building
- ▶ Bridge construction



# THE FLEXIBILITY YOU NEED



**Special Financing offers\***



**1<sup>st</sup> Handover / Free service visit\***



**Trade-in deals\***



**Parts commitment\***

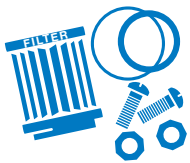

**Parts commonality across Genie telehandler line**



**Easy of maintenance**



**Robust performance**

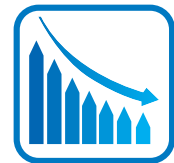

**Low running cost**

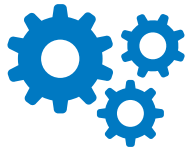

**Hydrostatic transmission**

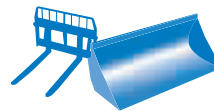

**Wide range of attachments**

**Genie**  
A TEREX BRAND

## Corporate Headquarters: United States

18340 NE 76th Street, P.O. Box 97030, Redmond, Washington 98073-9730

Telephone +1 (425) 881-1800 · Fax +1 (425) 883-3475

[www.genielift.com](http://www.genielift.com)

## Europe, Middle East, Africa and Russia

To view all our locations visit [www.genielift.co.uk/locations](http://www.genielift.co.uk/locations)

Email: [AWP-InfoEurope@terex.com](mailto:AWP-InfoEurope@terex.com) / [AWP-InfoME@terex.com](mailto:AWP-InfoME@terex.com)

[www.genielift.co.uk](http://www.genielift.co.uk) / [www.genielift.me](http://www.genielift.me)

## Worldwide Manufacturing And Distribution

Australia · Brazil · Caribbean · Central America · China · France · Germany · Italy · Japan · Korea · Mexico  
Russia · Southeast Asia · Spain · Sweden · United Arab Emirates · United Kingdom · United States

Effective Date: January 2016. Product specifications and prices are subject to change without notice or obligation. The photographs and/or drawings in this document are for illustrative purposes only. Refer to the appropriate Operator's Manual for instructions on the proper use of this equipment. Failure to follow the appropriate Operator's Manual when using our equipment or to otherwise act irresponsibly may result in serious injury or death. The only warranty applicable to our equipment is the standard written warranty applicable to the particular product and sale and we make no other warranty, express or implied. Terex, Genie and Taking You Higher are trademarks owned by Terex Corporation or its subsidiaries. © 2016 Terex Aerial Work Platforms.



\*Subject to Terex AWP terms and conditions. Offers limited in time. Contact your Genie sales team.