

GROVE®

GMK4100B ■



features

- 36-167 ft. (11.1-51 m) 6 section full power Mega Form boom with Twin Lock pinning
- 28.5-49 ft. (8.7-15 m) hydraulic offset bi-fold swingaway
- 1 x 19.7 ft. (6 m) intermediate lattice insert
- 37,000 lb. (16.8 t) counterweight with hydraulic removal system
- Mercedes-Benz OM 501 LA, 390 hp (290 kW), torque 1365 ft./lb. (1850 Nm)
- MEGATRAK independent hydro-pneumatic suspension

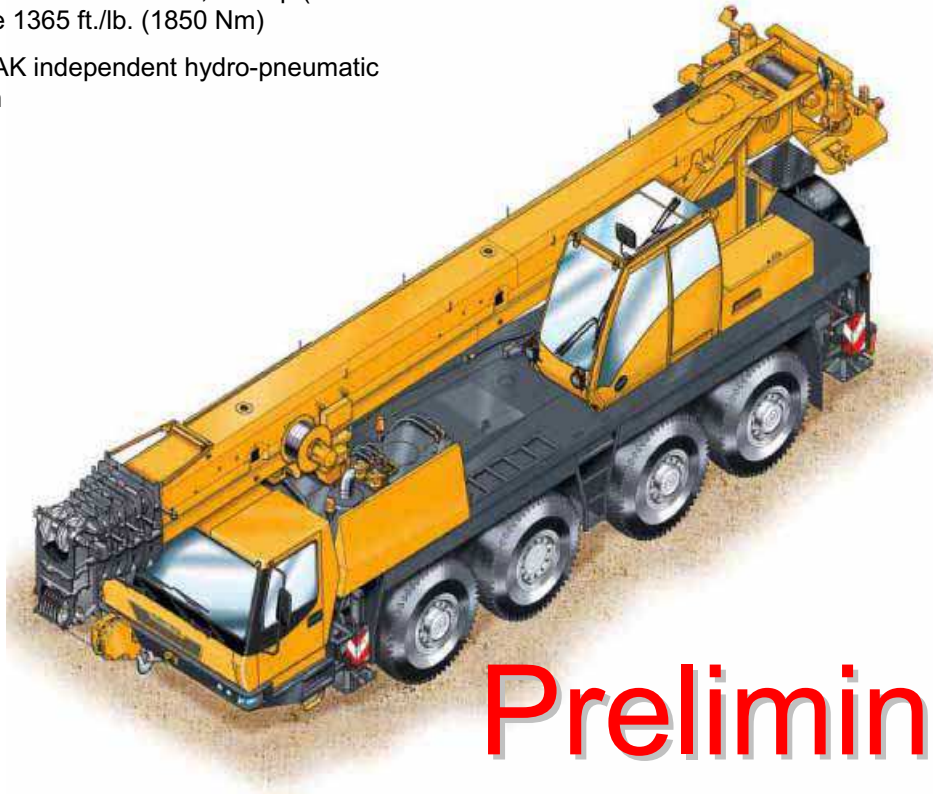

Preliminary

All Terrain Crane

Anitowoc®
Crane Group

Above. Beyond. Everywhere.™

Superstructure Specifications

Boom

36 ft. - 167 ft. (11.1 m - 51 m) 6 section, full power Mega Form boom with Twin Lock Pinning .
Maximum tip height: 177 ft. (54 m)

Boom Nose

Six nylatron sheaves, mounted on heavy duty tapered roller bearings with removable pin-type rope guards. Quick reeve boom nose. Removable auxiliary boom nose with removable pin type rope guard.

Boom Elevation

Single lift cylinder with safety valve provides boom angle from -3° to +82°.

Hydraulic Offsettable Lattice Extension

28.5 ft. – 49 ft. (8.7 - 15 m) bi-fold lattice swingaway extension, hydraulically offsettable and luffing under load, 0°- 40°.
Maximum tip height: 226 ft (69 m)

*Offsettable Lattice Extension

28.5 ft. – 49 ft. (8.7 - 15 m) bifold lattice swingaway extension, manual offsettable at 0°, 20° and 40°.
Maximum tip height: 226 ft. (69 m)

* Lattice Extension

One 19.7 ft. (6 m) insert for use with lattice swingaway extension to increase length to 69 ft. (21 m). Maximum tip height: 246 ft (75 m)

Load Moment & Anti-Two Block System

Load moment and anti-two block system with audio/visual warning and control lever lockout provides electronic display of boom angle, length, radius, tip height, relative load moment, maximum permissible load, load indication and warning of impending two-block condition.

Cab

All aluminum constructed cab with acoustical lining, hydraulic tilted to 20°. Includes tinted safety glass, adjustable operator's seat with hydraulic suspension, opening windows at side and rear, hinged windshield with wiper, sun visor and window shade. Other features include diesel heater/defroster, armrest integrated crane controls, drive/steer controls and ergonomically arranged instrumentation.

Swing

2 axial piston planetary gear boxes with fixed displacement motors. Infinitely variable to 1.8 rpm. Free swing with holding (rocker switch) and service (foot pedal) brake.

Counterweight

37,000 lbs. (16.8 t) consisting of various sections with hydraulic installation/removal system controlled from the superstructure cab.

Hydraulic System

2 separate circuits, 1 axial piston variable displacement pump (load sensing) with electronic power limiting control and 1 gear pump for swing. Thermostatically controlled oil coolers keep oil at optimum operating temperature.

Tank capacity: 180 gal. (680 l)

Hoist

Main and auxiliary hoist are powered by axial piston motor with planetary gear and brake. "Thumb-thumper" hoist drum rotation indicator alerts operator of hoist movement.

	Main	Auxiliary
Line length:	720 ft. (220 m)	720 ft. (220 m)
Rope diameter:	16 mm	16 mm
Line speed:	410 ft./min. (125 m/min)	410 ft./min. (125 m/min)
Line pull:	11,240 lbs. (50 kN)	11,240 lbs. (50 kN)

*Denotes optional equipment

Carrier Specifications

Chassis

Box type, torsion resistant frame is fabricated from high strength steel.

Outrigger System

Four hydraulic single stage outrigger beams with vertical cylinders and outrigger pads, 19.7" (500 mm) square .

Outrigger can be set in 4 positions:

Full	- 23' (7 m)
Partial	- 19.7' (6 m)
Partial	- 16.4' (5 m)
Retracted	- 7.6' (2.3 m)

Independent horizontal and vertical movement controlled from each side of carrier and the superstructure cab.

Electronic crane level indicators.

Engine

Mercedes-Benz OM 501 LA six cylinder, water cooled, turbo-charged, with 390 bhp (290 kW) @ 1800 rpm.

Max. torque 1,365 ft./lb. (1 850 Nm) @ 1080 rpm.

Compression and exhaust brakes.

Engine emissions: EUROMOT/EPA/CARB (off road)

Fuel Tank Capacity

106 gallons (400 L).

Transmission

ZF, AS Tronic, 12 speeds forward, 2 reverse.

Drive/Steer

8X6X8

Axles

1st axle line – drive/steer

2nd axle line – steer (optional drive)

3rd axle line – drive/steer (connects for all wheel steer)

4th axle line – drive/steer

Drive axles with planetary hub reduction and center mounted gearing. Inter-axle and cross axle differential locks.

Suspension

Grove exclusive MEGATRAK suspension. Independent hydro-pneumatic system acting on all wheels with hydraulic lockout. Suspension can be raised 6.5" (170 mm) or lowered 5" (130 mm) both longitudinally and transversely. Features an automatic leveling system for highway travel.

Tires

6 tires, 16.00R25 (Vehicle width – 9.0' [2.75 m])

Steering

Dual circuit, hydraulic power assisted steering system. Transfer case mounted, ground driven emergency steering pump. Axles 1,2 and 4 steer on highway. Separate steering of the 3rd and 4th axles for all wheel and crab steering, controlled by an electronic rocker switch.

Brakes

Service brakes: pneumatic dual circuit acting on all wheels. Standard anti-lock brake system (ABS).

Parking brake: pneumatically operated spring loaded brake acting on axle lines 2 and 4.

Air dryer.

Cab

Two-man, aluminum construction with the following features: safety glass, driver and passenger seats with hydraulic suspension, engine-dependent hot water heater, complete instrumentation and driving controls. Cab tilts forward for easy engine access.

Electrical System

24V system with three phase alternator, 28V/100A 2 batteries, 12V/170 Ah

Maximum Speed

49 mph (78.5 kph) 14.00 tires

53 mph (85 kph) 16.00/20.5 tires

Gradeability (Theoretical)

70% - 14.00 tires

63% - 16.00/20.5 tires

Miscellaneous Standard Equipment

Work light; tool kit; fire extinguishers; auxiliary boom nose; radio /CD player in carrier cab, heated rear view mirrors, wind speed indicator.

Optional Equipment

*Work lights, mounted on boom base section

*Boom mounted aircraft warning light

*Timer for diesel heater

*Radio/CD player for superstructure cab

*Stainless steel exhaust system with spark arrestor

*Air conditioning

*Hook blocks/Headache Ball

*14.00R25 tires (vehicle width 8.4 ft.(2.55 m)

*20.5R25 tires (vehicle width 9.5 ft.(2.88 m)

*8x8x8 drive/steer

*Electric driveline retarder

*Engine independent diesel cab heater, with engine pre-heater

*Strobe light

*Cab mounted work light

*Working range limiter

*Work lights for outriggers

*Data logger

*Spare tire and wheel with carry bracket

*Aluminum edging for decking

*Rear mounted stowage box

*Outrigger pad load indicator

*Denotes optional equipment

Weights & Dimensions

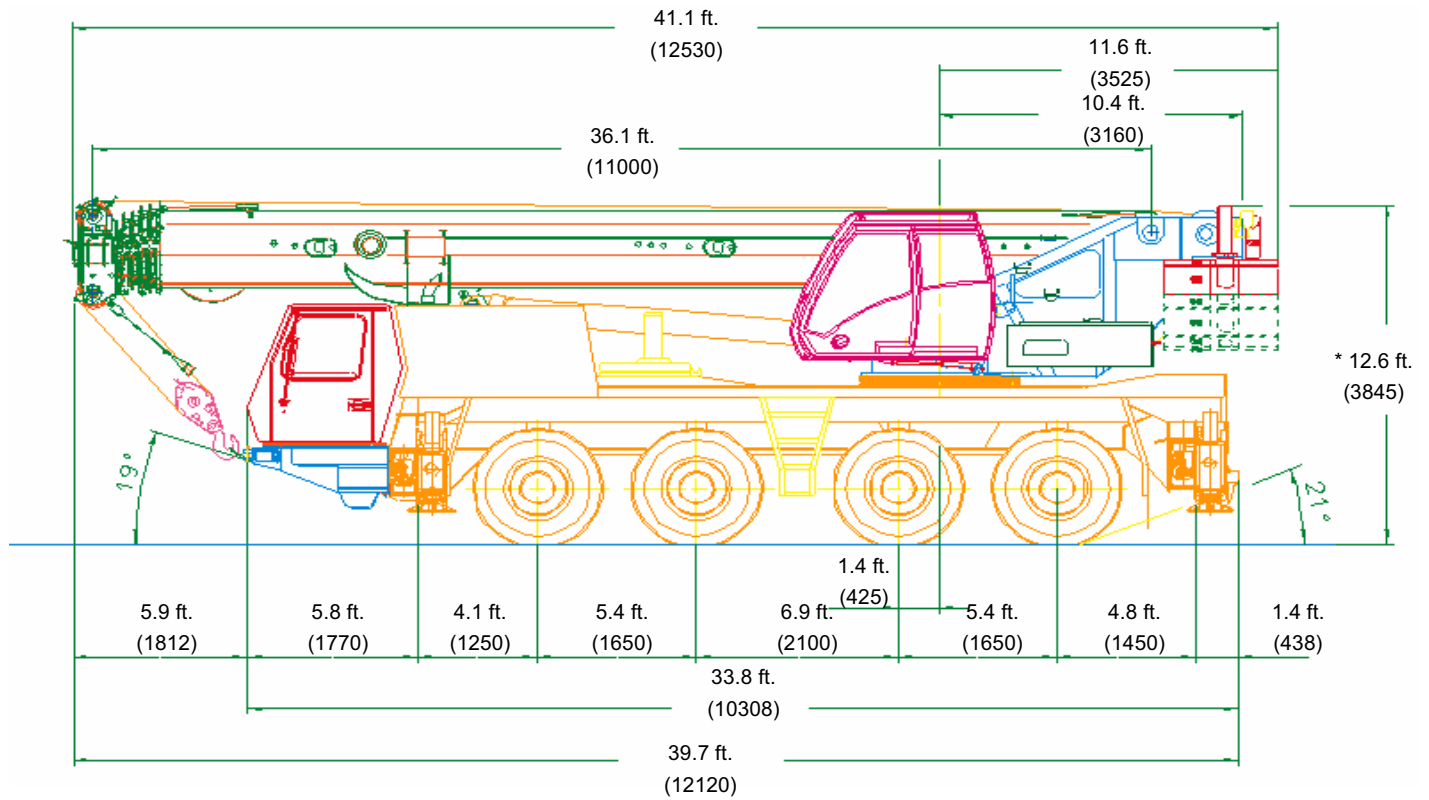

* 14.00 tires

Basic Weights - lb. (kg.)	Axles 1 & 2		Axles 2 & 3		Total	
Mercedes power, 14.00R25 tires, 8x6x8 drive/steer, 20,500 lb. (9.3 t) counterweight	52,910	(24 000)	52,910	(24 000)	105,820	(48 000)

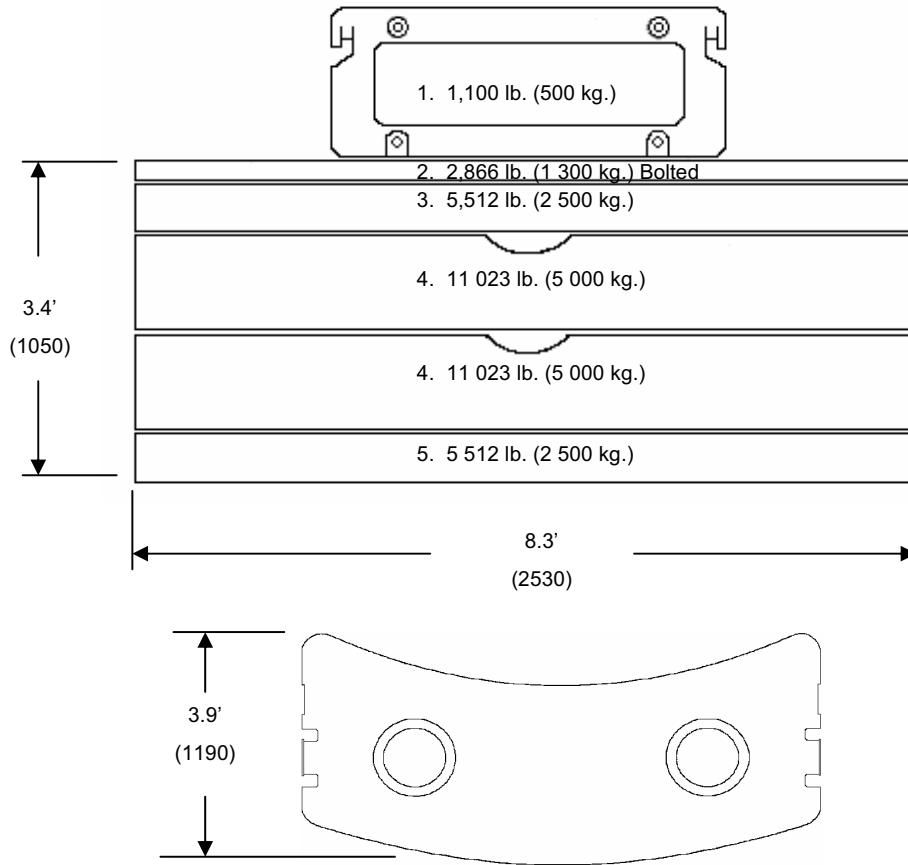

Counterweight Configurations

lb. (kg.)	1	2	3	4	5
3,900 (1 800)	x	x			
9,400 (4 300)	x	x			x
14,900 (6 800)	x	x	x		x
20,500 (9,300)	x	x		x	x
26,000 (11 800)	x	x	x	x	x
31,500 (14 300)	x	x		2x	x
37,000 (16 800)	x	x	x	2x	x

Range Diagram

X 1000 lb.

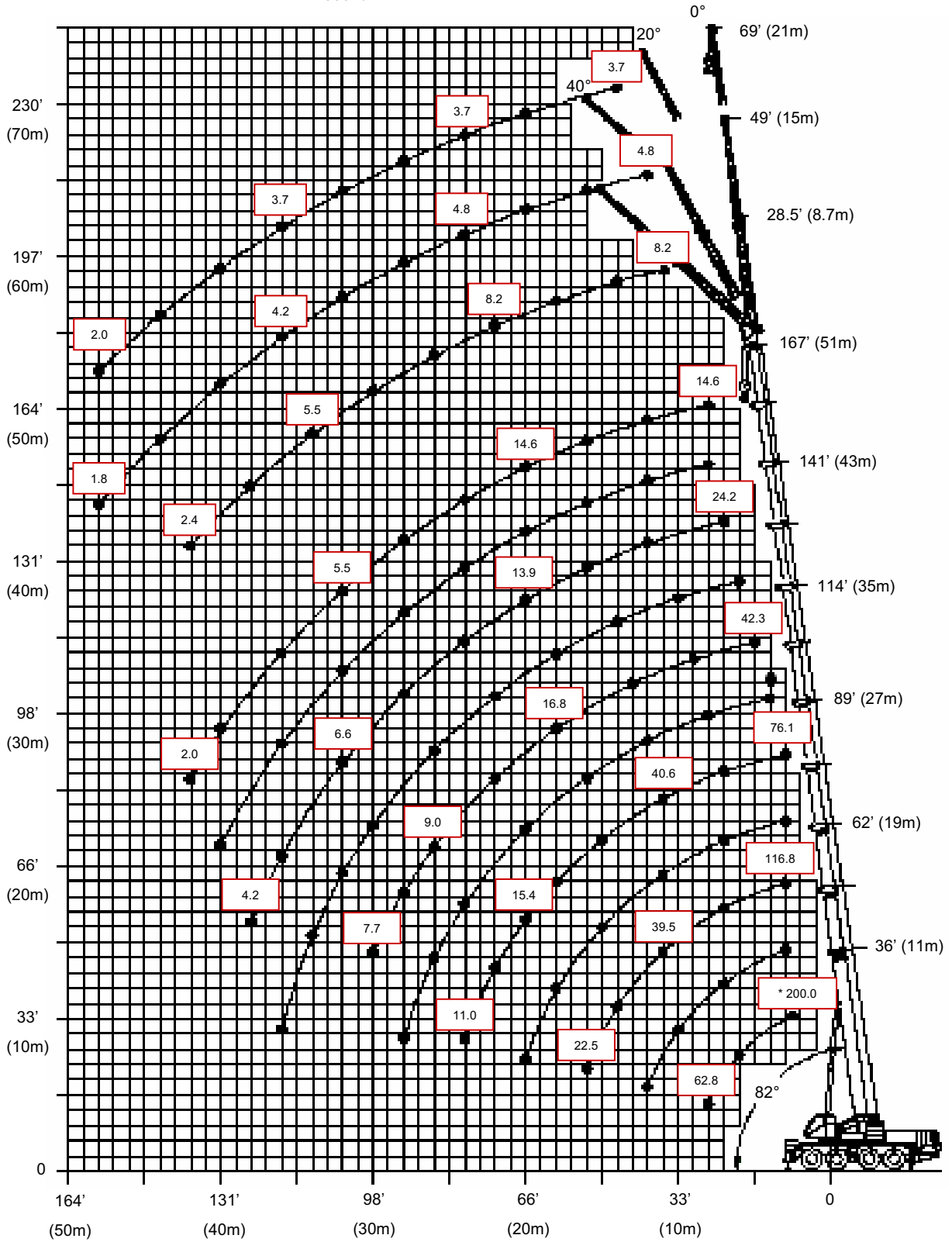

Preliminary

Main Boom

360° (75% Stability)

Maximum Counterweight

Outriggers Fully Extended

RADIUS	Boom Length											RADIUS
	36.1'	49.5'	62.3'	75.5'	88.6'	102.4'	114.2'	128'	141.1'	154.2'	167.3'	
8	* 200.0											8
9	158.0											9
10	148.0	125.0	116.0	102.0	76.0							10
15	108.0	104.0	96.0	91.0	76.0	57.0						15
20	86.0	85.0	83.0	77.0	73.0	57.0	42.4	31.4				20
25	66.0	68.0	67.0	63.0	62.0	55.0	42.4	31.4	24.2			25
30		53.0	52.0	52.0	49.0	48.0	39.8	31.4	24.2	18.2	14.6	30
35		40.8	41.6	41.0	41.6	39.4	36.0	31.0	24.2	18.2	14.6	35
40			33.4	33.4	34.4	32.8	30.8	29.0	24.2	18.2	14.6	40
45			27.8	29.0	28.6	27.6	26.2	25.4	24.0	18.2	14.6	45
50			24.2	24.6	24.2	23.2	22.4	21.8	21.4	18.2	14.6	50
55				21.2	20.8	19.8	19.0	19.0	18.8	17.8	14.6	55
60				18.2	17.8	17.0	16.2	16.8	16.4	16.6	14.6	60
65				16.0	15.6	14.6	14.0	15.8	14.2	14.8	14.6	65
70					13.6	12.8	12.0	14.0	12.8	13.6	13.2	70
75					12.0	11.0	10.6	12.6	11.8	12.4	11.8	75
80						9.6	9.6	11.4	10.8	11.0	10.2	80
85						8.4	9.0	9.8	9.8	9.8	9.2	85
90						6.2	8.4	8.8	9.0	8.6	8.0	90
95							8.0	7.8	8.0	7.6	7.0	95
100								6.8	7.2	6.8	6.2	100
105								6.2	6.4	6.0	5.6	105
110								5.4	5.8	5.2	4.8	110
115								3.8	5.2	4.8	4.2	115
120									4.6	4.2	3.6	120
125										3.8	3.0	125
130										3.2	2.6	130
135											2.2	135

* Over the rear with special equipment

Preliminary

Boom Extensions

360° (75% Stability)

Maximum Counterweight

Outriggers Fully Extended

Boom Extension Length										
Radius	28.5'			49'			69'			Radius
	0°	20°	40°	0°	20°	40°	0°	20°	40°	
x 1000 lb.										
40.0	8.2			4.8						40.0
45.0	8.2			4.8						45.0
50.0	8.2	8.0		4.8			3.8			50.0
55.0	8.2	8.0	7.0	4.8			3.8			55.0
60.0	8.2	8.0	6.8	4.8	4.6		3.8			60.0
65.0	8.2	8.0	6.8	4.8	4.4		3.8			65.0
70.0	8.2	7.8	6.6	4.8	4.2		3.8	3.8		70.0
75.0	8.2	7.6	6.6	4.8	4.2	3.6	3.8	3.8		75.0
80.0	8.2	7.4	6.6	4.8	4.2	3.6	3.8	3.8	3.4	80.0
85.0	8.2	7.2	6.6	4.8	4.0	3.6	3.8	3.8	3.4	85.0
90.0	8.0	7.2	6.6	4.8	4.0	3.4	3.8	3.8	3.4	90.0
95.0	7.4	7.0	6.6	4.8	3.8	3.4	3.8	3.8	3.4	95.0
100.0	6.6	6.8	6.4	4.8	3.8	3.4	3.8	3.8	3.4	100.0
105.0	5.8	6.2	6.4	4.6	3.8	3.4	3.8	3.8	3.4	105.0
110.0	5.0	5.4	5.8	4.4	3.6	3.4	3.8	3.6	3.4	110.0
115.0	4.4	4.8	5.0	4.2	3.6	3.4	3.8	3.6	3.2	115.0
120.0	3.8	4.2	4.4	4.0	3.6	3.2	3.8	3.4	3.0	120.0
125.0	3.2	3.8	3.8	3.8	3.6	3.0	3.8	3.4	3.0	125.0
130.0	2.8	3.2	3.2	3.2	3.4	3.0	3.4	3.4	3.0	130.0
135.0	2.4	2.8	2.8	2.8	3.2	3.0	3.0	3.4	3.0	135.0
140.0		2.2		2.4	3.0	3.0	2.4	3.0	3.0	140.0
145.0					2.6	2.8	2.2	2.6	3.0	145.0
150.0					2.2	2.4	1.8	2.2	2.6	150.0
155.0						2.0		2.0	2.2	155.0

GMK 4100B Features and Benefits

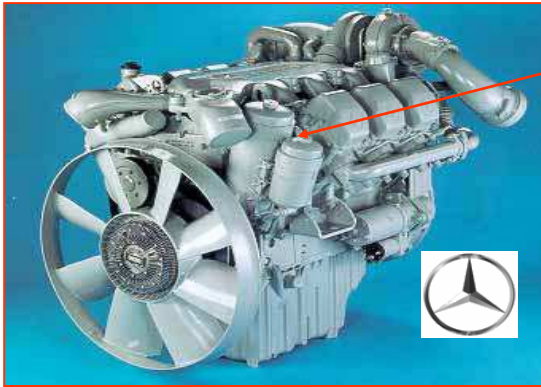

Mercedes-Benz OM501LA
 390 bhp (290 kW) @ 1800 rpm
 1365 ft./lb. torque (1850 Nm) @ 1080 rpm

ZF AS Tronic
 12 speeds fwd, 2 rev

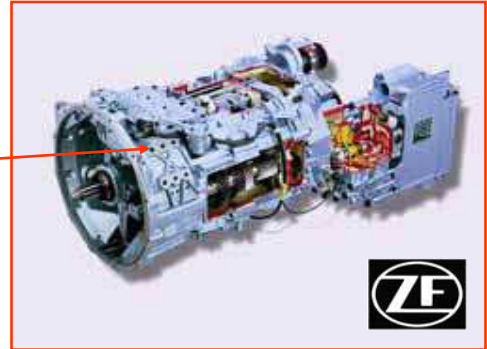

TWIN-LOCK

Boom pinning mechanism automatically pins the sections in position using two horizontal large diameter boom pins

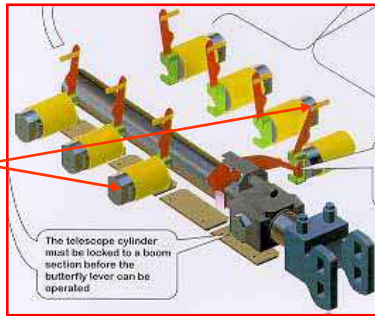

LUFFING BI-FOLD SWINGAWAY

Hydraulically offset lattice bi-fold swingaway lets the operator set the offset from 0°-40° while under load, from the superstructure cab



MEGATRAK

Independent suspension and all wheel steer system allows wheels to remain on the ground at all times so stresses and weight are not continually transferred between axles

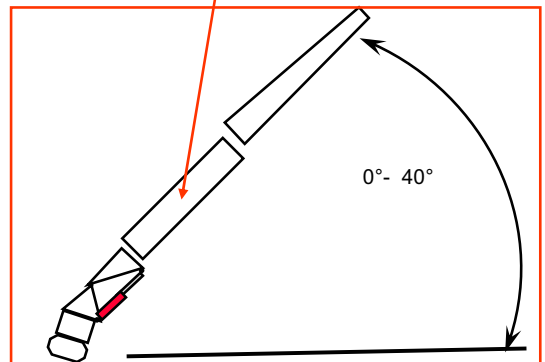

Constant improvement and engineering progress make it necessary that we reserve the right to make specification, equipment, and price changes without notice. Illustrations shown may include optional equipment and accessories and may not include all standard equipment.

GROVE and GROVE LOGO are registered trademarks of GROVE in the U.S. and/or other countries. Copyright 2002 GROVE. All rights reserved.

Grove Worldwide--Headquarters
 1565 Buchanan Trail East
 P.O. Box 21
 Shady Grove, Pennsylvania 17256-0021
 USA
 Tel: (717)597-8121
 Fax: (717)597-0462
 www.manitowoccrane.com

Rev
 08/09/2005