

GROVE®

RT890E

product guide

features

- 90 Ton (80 mt) Capacity
- 38 ft.-142 ft. (11.4-43.2 m) 5 Section, Full Power Boom
- 33 ft.-56 ft. (10-17 m) Offsettable Bi-fold Lattice, Swingaway Extension
- 16 ft. (4.8 m) or 32 ft. (9.7 m) Extension Inserts
- Grove "Megaform" Boom
- 22,000 lb. (9,979 kg) Counterweight. Hydraulically Installed and Removed.
- 275 HP (205 kW) Tier III Cummins Diesel Engine
- Grove "E" Series Cab



contents

Features	2
Specifications	3
Dimensions & Weights	5
Working Range	6
Mode A vs. (Mode B)	7
Load Chart (Mode B)	8
RT890E Load Chart Fixed Offset Swingaway	9
Working Range w/one 16' Insert	10
Working Range w/two 16' Inserts	11
Load Charts Fixed Offset Swingaway w/Inserts	12
Load Charts (Mode A)	13
Luffing Extension Charts	15
	16
	17
	18
Load Handling	19

Rough Terrain Hydraulic Crane

features

2



The Grove MEGAFORM™ boom shape eliminates weight and increases capacity compared to conventional shapes.



For improved up-and-over reach, a power luffing extension is available on the RT890E and hydraulically offsets from the superstructure cab from 5° to 40°.

Counterweight and auxiliary hoist is hydraulically removed/installed for easier hauling from job to job.



Electronically controlled Cummins diesel engine provides plenty of power at the jobsite.

RT890E

GROVE.

specifications

3

Superstructure

Boom

38 ft. - 142 ft. (11.4 m - 43.2 m) five-section, sequenced synchronized full power boom with A & B mode.
Maximum tip height: 150 ft. (45.7m).

Lattice Extension

33 ft. - 56 ft. (10 m - 17 m) offsettable bifold lattice swingaway extension. Offsets 0°, 20° and 40°. Stows alongside base boom section.

Maximum tip height: 206 ft. (62.7m).

*Optional Lattice Extension

33 ft. - 56 ft. (10 m - 17 m) hydraulically offsettable bifold lattice swingaway extension. Offsets from 0° to 40°. Stows alongside base boom section.

Maximum tip height: 206 ft. (62.7m).

*Optional Lattice Extension Inserts

(2) X 16 ft. (4.8 m) lattice extension inserts. Installs between the boom nose and bifold extension, non-stowable.

Maximum tip height: 238 ft. (72.5m)

Boom Nose

Five nylatron sheaves mounted on heavy duty tapered roller bearings with removable pin-type rope guards. Quick reeving type boom nose. Removable auxiliary boom nose with removable pin type rope guard.

Boom Elevation

One double acting hydraulic cylinder with integral holding valve provides elevation from -3° to +78°.

Load Moment & Anti-Two Block System

Standard "Graphic Display" load moment and anti-two block system with audio-visual warning and control lever lockout. These systems provide electronic display of boom angle, length, radius, tip height, relative load moment, maximum permissible load, load indication and warning of impending two-block condition. The standard Work Area Definition System allows the operator to pre-select and define safe working areas. If the crane approaches the pre-set limits, audio-visual warnings aid the operator in avoiding job-site obstructions.

Cab

Full-vision, all-steel fabricated with acoustical lining and tinted safety glass throughout. Cab tilts to + 20 degrees. Deluxe seat incorporates armrest-mounted hydraulic single-axis controllers. Dash panel incorporates gauges for all engine functions. Other standard features include: hot water heater, cab circulating air fan, sliding side and rear windows, sliding skylight with electric wiper and sunscreen, electric windshield wash/wipe, fire extinguisher and seat belt.

Swing

Two speed, planetary swing drive with foot applied multi-disc wet brake. Spring applied, hydraulically released swing brake. Single position mechanical house lock, operated from cab. Maximum speed: 2.0 RPM.

Counterweight

22,000 lb. (9,979 kg). Hydraulically installed and removed.

Hydraulic System

Two main pumps ([1] piston and [1] gear) with a combined capacity of 133 GPM (503 LPM).
Maximum operating pressure: 4,000 psi (277.7 bar).
Three section pressure compensated valve bank. Return line type filter with full flow by-pass protection and service indicator. Replaceable cartridge with micron filtration rating of 5/12/16.
263 gallon (995 L) hyd. reservoir. Carrier mounted oil cooler with thermostatically controlled hydraulic motor driven fan/air to oil. System pressure test ports.

Hoist Specifications (HP30-19G) Main and Auxiliary Hoist

Planetary reduction with automatic spring applied multi-disc wet brake. Electronic hoist drum rotation indicators, and hoist drum cable followers.

Maximum Single Line Pull:

1st layer: 20,250 lb(9,185 kg.)

3rd layer: 17,010 lb(7,715 kg.)

5th layer: 14,660 lb(6,650 kg.)

Maximum Permissible Line Pull:

16,800 lb. (7,620 kg.) with 6X37 class rope.

16,800 lb. (7,620 kg.) with 35x7 class rope.

Maximum Single Line Speed: 514 FPM (156 m/min)

Rope Construction:

6X36 EIPS IWRC, Special Flexible

35x7 Flex-X, Rotation Resistant

Rope Diameter: 3/4" (19 mm)

Rope Length:

Main Hoist: 600 ft. (182 m)

Auxiliary Hoist: 600 ft. (182 m)

Maximum Rope Stowage: 841 ft. (256 m)

RT890E

GROVE.

Courtesy of Crane.Market

specifications

4

Carrier

Chassis

Box section frame fabricated from high-strength, low alloy steel. Front/rear towing and tie down lugs.

Outrigger System

Four hydraulic telescoping single-stage double box beam outriggers with inverted jacks and integral holding valves. Three position setting, 0%, 50% and fully extended.

All steel fabricated, quick release type outrigger floats, 30.5" (775 mm) diameter.

Maximum outrigger pad load: 125,000 lb. (56,700 kg).

Outrigger Controls

Controls and crane level indicator located in cab.

Engine (Tier III)

Cummins QSB 6.7L diesel, six cylinders, turbo-charged, 275 bhp (205 kW) (Gross) @ 2,500 RPM.

Maximum torque: 728 ft. lb. (987 Nm) @ 1,500 RPM.

Fuel Tank Capacity

72 gallons (273 L)

Transmission

Full rangeshift with 6 forward and 6 reverse speeds.

Front axle disconnect for 4 x 2 travel.

Electrical System

Two 12 V - maintenance free batteries.

12 V starting and lighting. Battery disconnect. CanBus Diagnostic system.

Drive

4 x 4.

Steering

Fully independent power steering:

Front: Full hydraulic steering wheel controlled.

Rear: Full hydraulic switch controlled.

Provides infinite variations of 4 main steering modes: front only, rear only, crab and coordinated.

Rear steer indicator.

Turning radius: 25 ft.

Axles

Front: Drive/steer with differential and planetary reduction hubs rigid mounted to frame.

Rear: Drive/steer with differential and planetary reduction hubs pivot mounted to frame.

Oscillation Lockouts

Automatic full hydraulic lockouts on rear axle permits 10 in. (25.4 cm) oscillation only with boom centered over the front.

Brakes

Full hydraulic split circuit operating on all wheels. Spring-applied, hydraulically released parking brake mounted on front axle.

Tires

Std. 29.5 x 25 - 34 bias ply, General

Lights

Full lighting including turn indicators, head, tail, brake and hazard warning lights.

Maximum Speed

22 MPH (35 kph).

Gradeability (Theoretical)

75%

(Based on 115,976 lb. [52,607 kg] GVW) 29.5 x 25 tires, 142 ft. (43.2 m) boom, plus 56 ft. (17.0 m) swingaway, 22,000 lb. counterweight, 90T hookblock and 10T headache ball).

Miscellaneous Standard Equipment

Full width steel fenders, full length aluminum decking, dual rear view mirrors, hook-block tie down, electronic back-up alarm, light package, front stowage well, tachometer/hourmeter, rear wheel position indicator, 36,000 BTU hot water cab heater, hoist mirrors, engine distress A/V warning system, front/rear tie down and tow lugs, coolant sight level indicator,.

OPTIONAL EQUIPMENT

*AUXILIARY LIGHTING PACKAGE (includes cab mounted amber flashing light, hoist mounted work light, and dual base boom mounted floodlights.)

*LMI light bar (in cab)

*Air conditioning (28,500 BTU).

*360° NYC style mechanical swing lock.

*Rear Pintle hook.

*Cab controlled cross axle differential locks, (front and rear)

*PAT data logger.

*Rubber mat for stowage trough.

**Denotes optional equipment*

RT890E

GROVE.

Courtesy of Crane.Market

dimensions & weights

Tire Size	A	B	C	D	E	F	G	A	B	C	D	E	F	G
29.5x25	15.7 (619)	16.3 (644)	13.6 (536)	12.9 (509)	12. (492)	10.1 (398)	8.8 (346)	11.1 (438)	11.6 (457)	8.4 (332)	7.8 (306)	7.3 (289)	4.9 (194)	4.1 (162)
	2 WHEEL STEER							4 WHEEL STEER						

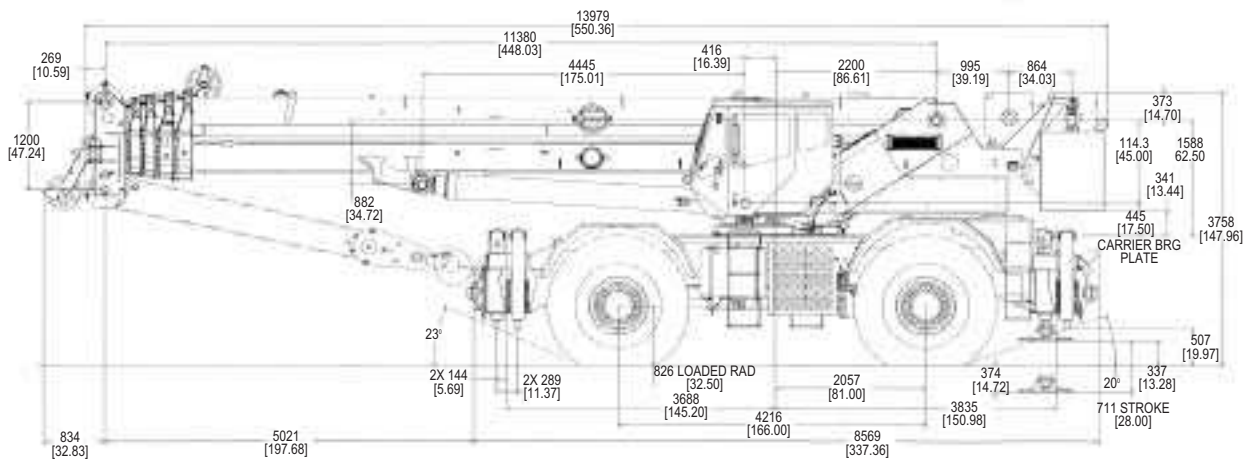
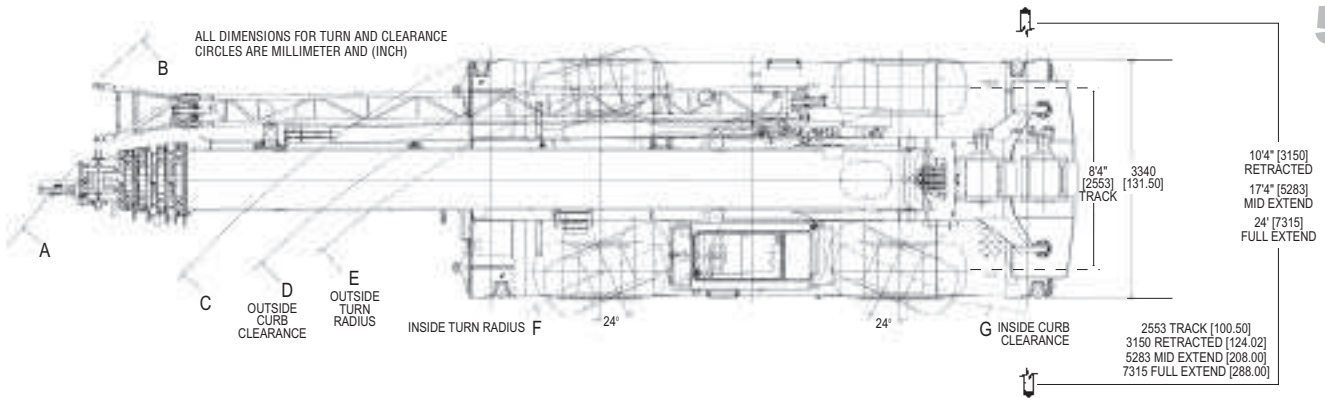

Weights

	Gross		Front		Rear	
	(lbs.)	(kg.)	(lbs.)	(kg.)	(lbs.)	(kg.)
Basic Machine including 142 ft. main boom, main and aux. hoist with 600 ft. of rope, manual offsettable bifold swingaway, full counterweight, 10T headache ball, and 90T hookblock:	115,976	52 607	56,878	25 800	59,098	26 807
SUB: Hydraulic offsettable bifold swing-away	116,677	52 925	57,997	26 307	58,680	26 617
Remove counterweight and aux. hoist (Manual offsettable S/A)	93,973	42 626	67,216	30 489	26,757	12 137
Remove counterweight and aux. hoist (Hyd. offsettable S/A)	94,674	42 944	68,335	30 997	26,339	11 947
Remove counterweight, aux. hoist, and manual offsettable S/A	91,456	41 484	63,313	28 719	28,143	12 766
Remove counterweight, aux. hoist, and hyd. offsettable S/A	91,178	41 633	63,765	28 924	28,018	12 709

RT890E

working range

Working range – 141.7 ft. Main Boom 32-56 ft. Fixed Offset Swingaway

6

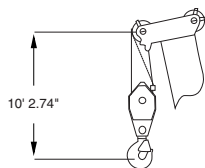
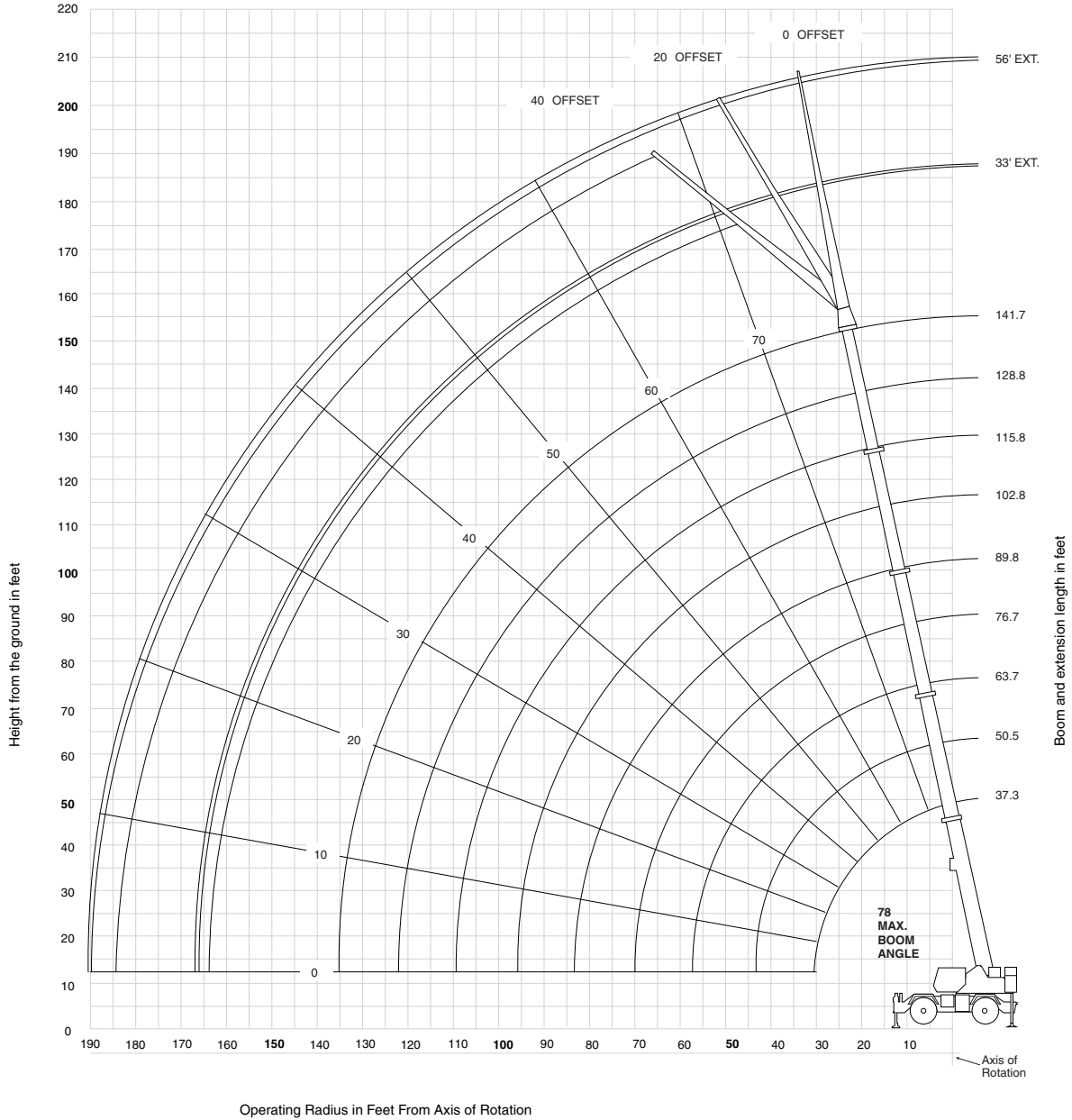

Dimensions are for Largest Grove furnished Hook Block and Headache Ball, with Anti-Two Block Activated.

THIS CHART IS ONLY A GUIDE AND SHOULD NOT BE USED TO OPERATE THE CRANE. The individual crane's load chart, operating instructions and other instructional plates must be read and understood prior to operating the crane.

RT890E

GROVE

Courtesy of Crane.Market

mode A vs. mode B

7

Mode A – Inner-Mid Retracted

Boom sections:	Main Boom Length in Feet							
	37.3	50.4	63.4	76.4	89.4	102.4	115.4	141.7
	Percent Extension							
Inner-mid	0	0	0	0	0	0	0	100
Center-mid	0	50	100	100	100	100	100	100
Outer-mid	0	0	0	25	50	75	100	100
Fly	0	0	0	25	50	75	100	100

Mode B – Normal Mode

Boom sections:	Main Boom Length in Feet								
	37.3	50.5	63.7	76.7	89.8	102.8	115.8	128.8	141.7
	Percent Extension								
Inner-mid	0	50	75	75	100	100	100	100	100
Center-mid	0	0	25	75	100	100	100	100	100
Outer-mid	0	0	0	0	0	25	50	75	100
Fly	0	0	0	0	0	25	50	75	100

THIS CHART IS ONLY A GUIDE AND SHOULD NOT BE USED TO OPERATE THE CRANE. The individual crane's load chart, operating instructions and other instructional plates must be read and understood prior to operating the crane.

RT890E

GROVE

Courtesy of Crane.Market

load charts (mode B)

 37.3 - 141.7 ft.
  22,000 lbs
  100%
 24 ft. spread
  360...

8

Feet	Main Boom Length in Feet								
	37.3	50.5	63.7	76.7	89.8	102.8	115.8	128.8	141.7
10	180,000 (68.5)	134,000 (75)	*97,500 (78)						
12	156,000 (65)	134,000 (72.5)	97,500 (76.5)						
15	128,500 (59.5)	127,500 (69)	97,500 (74)	69,950 (77)	*46,600 (78)				
20	98,650 (49.5)	97,600 (62.5)	86,200 (69)	63,600 (73)	46,600 (76.5)	*38,700 (78)			
25	78,800 (36.5)	77,800 (55.5)	74,850 (64)	55,100 (69)	41,950 (73)	38,700 (75.5)	*37,900 (78)	*30,850 (78)	
30	51,550 (12.5)	58,700 (47.5)	59,300 (58.5)	48,150 (65)	37,350 (69.5)	37,900 (72.5)	35,000 (75)	30,850 (77.5)	*24,400 (78)
35		43,250 (38.5)	43,200 (52.5)	42,450 (60.5)	33,300 (66)	33,200 (69.5)	30,950 (72.5)	28,900 (75)	24,400 (77)
40		33,250 (26)	32,850 (46.5)	33,050 (56)	29,850 (62.5)	29,300 (66.5)	27,450 (70)	25,850 (72.5)	24,250 (75)
45			25,650 (39)	26,000 (51)	25,900 (58.5)	25,950 (63.5)	24,450 (67)	23,150 (70)	21,900 (73)
50			20,350 (30.5)	20,750 (45.5)	20,550 (54.5)	21,950 (60)	21,800 (64.5)	20,750 (67.5)	19,800 (70.5)
55			16,200 (16.5)	16,800 (39.5)	16,450 (50)	17,800 (56.5)	19,150 (61.5)	18,650 (65)	17,900 (68.5)
60				13,600 (33)	13,200 (45.5)	14,550 (53)	15,900 (58.5)	16,800 (62.5)	16,150 (66)
65				11,000 (23.5)	10,600 (40.5)	11,900 (49)	13,250 (55.5)	14,200 (60)	14,650 (64)
70					8,420 (34.5)	9,750 (45)	11,050 (52)	11,950 (57)	12,850 (61.5)
75					6,570 (28)	7,910 (40.5)	9,250 (48.5)	10,100 (54.5)	10,950 (59)
80					4,960 (18)	6,340 (36)	7,670 (45)	8,530 (51.5)	9,380 (56.5)
85						4,990 (30)	6,320 (41)	7,150 (48.5)	7,980 (54)
90						3,780 (23)	5,140 (37)	5,950 (45)	6,770 (51)
95						2,710 (10)	4,100 (32)	4,900 (41.5)	5,700 (48.5)
100							3,160 (26)	3,960 (37.5)	4,750 (45.5)
105							2,310 (18.5)	3,130 (33.5)	3,910 (42)
110								2,370 (28.5)	3,150 (38.5)
115								1,680 (22.5)	2,460 (35)
120								1,050 (13)	1,840 (30.5)
125									1,250 (25.5)

Minimum boom angle (deg.) for indicated length (no load)

0 24

Maximum boom length (ft.) at 0 deg. boom angle (no load)

128.8

#LMI operating code. Refer to LMI manual for instructions.

*This capacity is based upon maximum obtainable boom angle.

Note: () Boom angles are in degrees.

Lifting Capacities at Zero Degree Boom Angle

Boom Angle	Main Boom Length in Feet						
	37.3	50.5	63.7	76.7	89.8	102.8	115.8
0i	27,500 (30.1)	15,950 (43.3)	9,560 (56.4)	5,840 (69.5)	2,730 (82.6)	1,910 (95.6)	1,200 (108.5)

Note: () Reference radii in feet.

A6-829-103321A

RT890E

THIS CHART IS ONLY A GUIDE AND SHOULD NOT BE USED TO OPERATE THE CRANE. The individual crane's load chart, operating instructions and other instructional plates must be read and understood prior to operating the crane.

GROVE

Courtesy of Crane.Market

RT890E load charts fixed offset swingaway



Pounds						
Feet	33 ft. LENGTH			56 ft. LENGTH		
	0 OFFSET #0021	20 OFFSET #0022	40 OFFSET #0023	0 OFFSET #0041	20 OFFSET #0042	40 OFFSET #0043
40	13,700 (78)					
45	13,700 (76.5)	*13,000 (78)		7,160 (78)		
50	13,700 (75)	12,950 (77.5)		7,160 (77.5)		
55	13,700 (73)	12,600 (76)	*10,250 (78)	7,160 (76)		
60	13,700 (71.5)	12,200 (74)	10,050 (77)	7,160 (74.5)	*6,400 (78)	
65	13,700 (69.5)	11,900 (72.5)	9,900 (75)	7,160 (73)	6,250 (77.5)	
70	13,500 (68)	11,550 (70.5)	9,750 (73)	7,160 (71.5)	6,110 (76)	
75	12,400 (66)	11,250 (68.5)	9,610 (71)	7,160 (70)	5,980 (74.5)	5,110 (78)
80	10,800 (64)	11,000 (67)	9,480 (69)	7,160 (68.5)	5,850 (73)	5,020 (77)
85	9,330 (62)	10,250 (65)	9,370 (67)	7,150 (66.5)	5,730 (71.5)	4,930 (75)
90	8,050 (60)	8,900 (63)	8,980 (65)	6,960 (65)	5,620 (69.5)	4,850 (73.5)
95	6,920 (58)	7,700 (61)	8,530 (63)	6,770 (63.5)	5,510 (68)	4,780 (71.5)
100	5,920 (56)	6,630 (59)	7,360 (61)	6,590 (61.5)	5,410 (66)	4,710 (69.5)
105	5,030 (54)	5,690 (56.5)	6,310 (58.5)	6,030 (60)	5,310 (64.5)	4,650 (68)
110	4,230 (52)	4,830 (54.5)	5,370 (56.5)	5,200 (58)	5,220 (62.5)	4,600 (66)
115	3,510 (49.5)	4,060 (52)	4,520 (54)	4,450 (56.5)	5,110 (60.5)	4,550 (64)
120	2,850 (47.5)	3,360 (50)	3,750 (51.5)	3,770 (54.5)	4,780 (59)	4,500 (62)
125	2,250 (45)	2,730 (47.5)	3,040 (49)	3,150 (52.5)	4,080 (57)	4,460 (60)
130	1,700 (42)	2,150 (44.5)	2,400 (46)	2,580 (50.5)	3,450 (55)	3,970 (58)
135	1,200 (39.5)	1,610 (42)		2,060 (48.5)	2,870 (53)	3,330 (55.5)
140		1,120 (39)		1,570 (46.5)	2,330 (50.5)	2,730 (53)
145				1,130 (44)	1,830 (48.5)	2,180 (50.5)
150					1,370 (46)	1,670 (48)
155						1,200 (45)
Minimum boom angle () for indicated length (no load)	38	38	40	43	44	44
Maximum boom length (ft.) at 0 boom angle (no load)		102.8			89.8	

NOTE: () Boom angles are in degrees.

A6-829-103447

#LMI operating code. Refer to LMI manual for operating instructions.
*This capacity is based upon maximum boom angle.

NOTES:

1. All capacities above the bold line are based on structural strength of boom extension and do not exceed 85% of tipping loads, in accordance with SAE J-765.
2. The 33 ft. extension length may be used with single or double part line lifting service. The 56 ft. extension length may be used for single line lifting service only.
3. For main boom lengths less than 141.7 ft. with the boom extension erected, the rated loads are determined by boom angle. Use only the column which corresponds to the boom extension length and offset for which the machine is set up. For boom angles not shown, use rating of the next lower boom angle.
4. **WARNING:** Operation of this machine with heavier loads than the capacities listed is strictly prohibited. Machine tipping with boom extension occurs rapidly and without advance warning.
5. Boom angle is the angle above or below horizontal of the longitudinal axis of the boom base section after lifting rated load.
6. Capacities listed are with outriggers properly extended and vertical jacks set only.
7. When lifting over the main boom nose with 33 ft. or 56 ft. extension erected, the outriggers must be fully extended or 50% extended (17.3 spread).

THIS CHART IS ONLY A GUIDE AND SHOULD NOT BE USED TO OPERATE THE CRANE. The individual crane's load chart, operating instructions and other instructional plates must be read and understood prior to operating the crane.

working range

Working range – 141.7 ft. Main Boom & One 16 ft. Insert

10

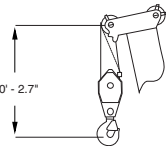
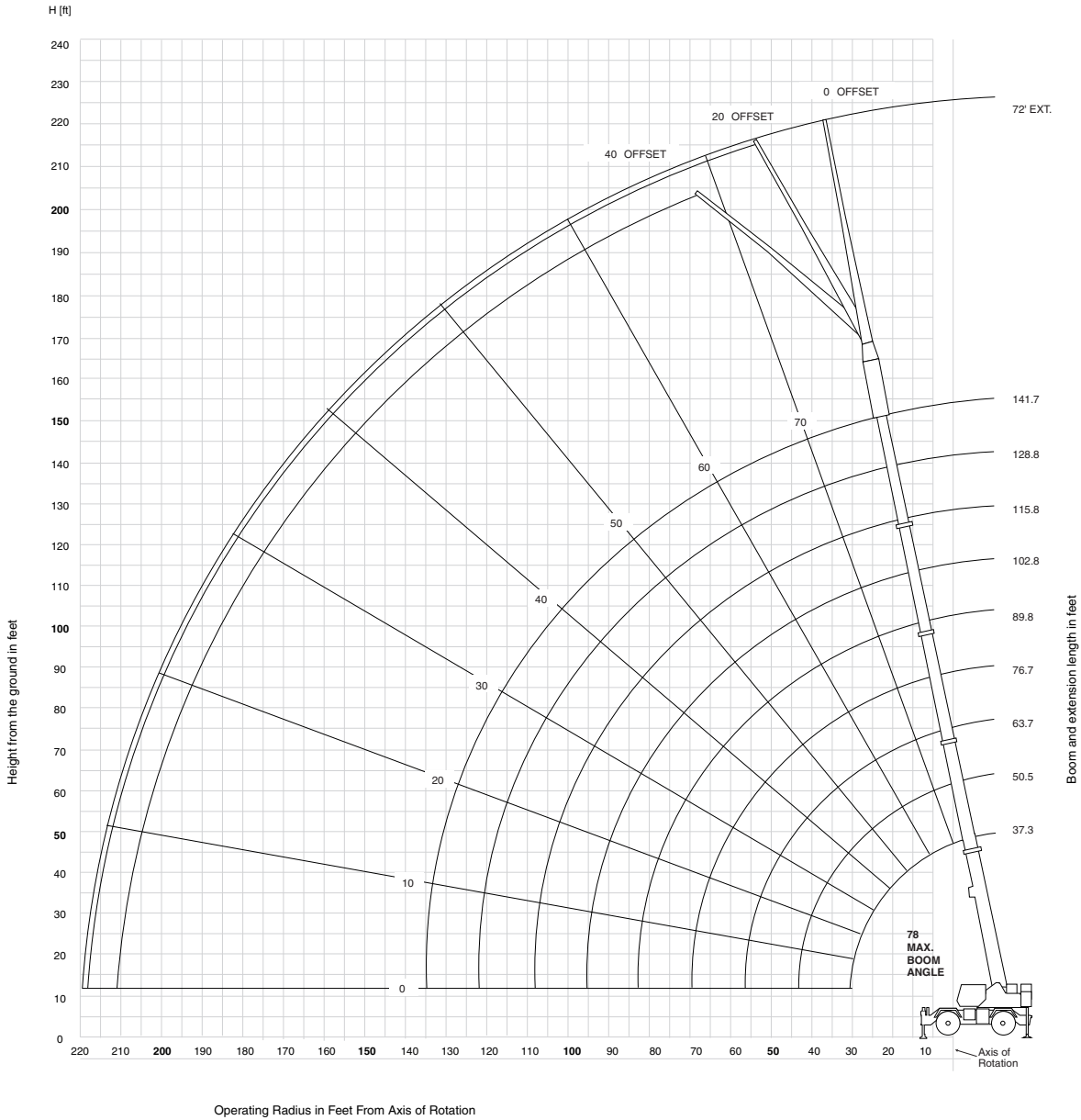

Dimensions are for Largest Grove furnished Hook Block and Headache Ball, with Anti-Two Block Activated.

RT890E

THIS CHART IS ONLY A GUIDE AND SHOULD NOT BE USED TO OPERATE THE CRANE. The individual crane's load chart, operating instructions and other instructional plates must be read and understood prior to operating the crane.

GROVE.

Courtesy of Crane.Market

working range

Working range – 141.7 ft. Main Boom & Two 16 ft. Inserts

11

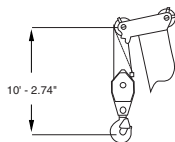
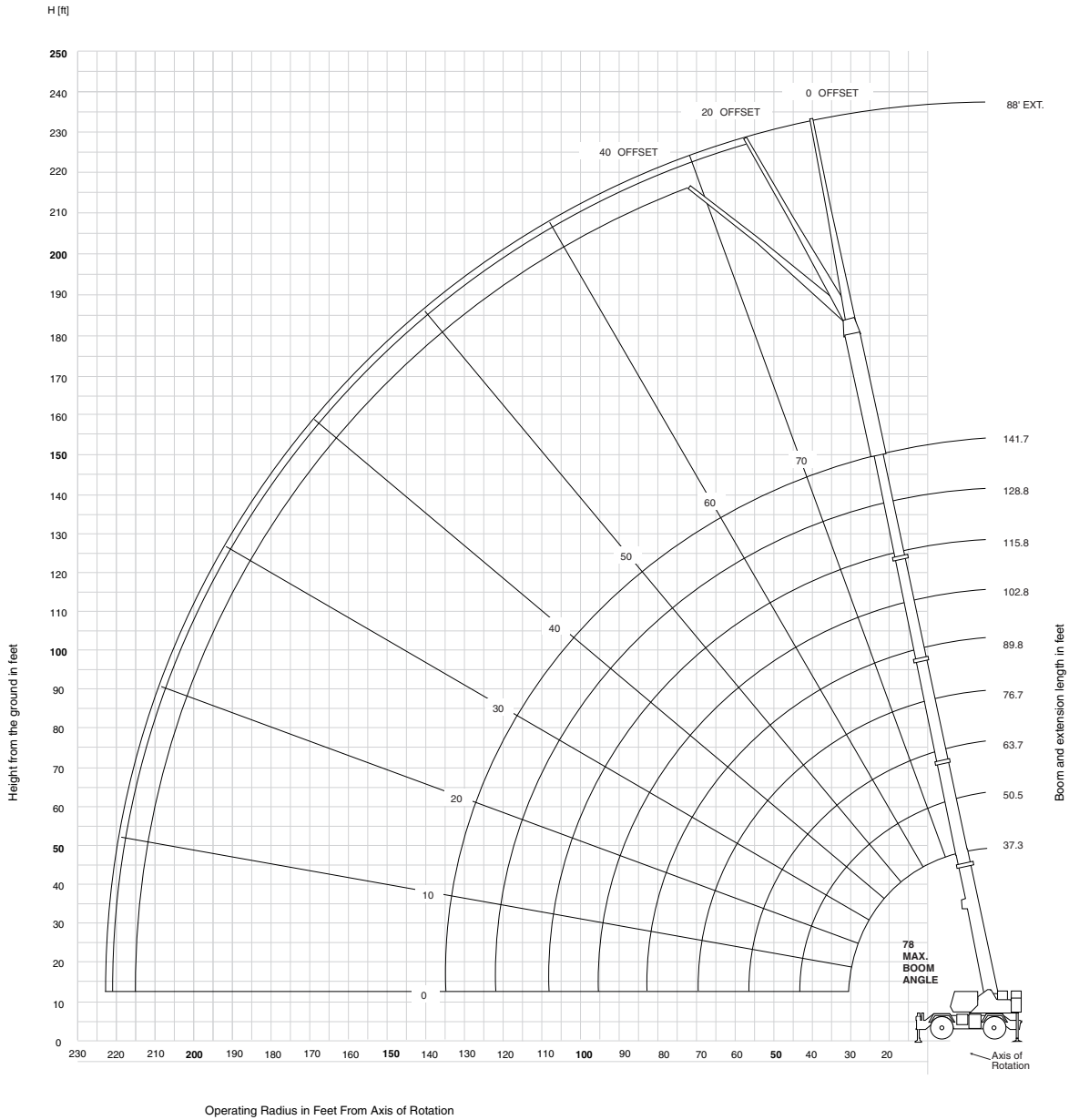

Dimensions are for Largest Grove furnished Hook Block and Headache Ball, with Anti-Two Block Activated.

THIS CHART IS ONLY A GUIDE AND SHOULD NOT BE USED TO OPERATE THE CRANE. The individual crane's load chart, operating instructions and other instructional plates must be read and understood prior to operating the crane.

RT890E

GROVE

Courtesy of Crane.Market

load charts fixed offset swingaway w/inserts

 37.3-141.7 ft.
  33 - 56 ft.
  1 or 2 16 ft Inserts
  22,000 lbs
  100%
  360...

12

Feet	Pounds					
	72 ft. (56 ft. LENGTH + 1 INSERT)			88 ft. (56 ft. LENGTH + 2 INSERTS)		
	0 _i OFFSET #0064	20 _i OFFSET #0065	40 _i OFFSET #0066	0 _i OFFSET #0084	20 _i OFFSET #0085	40 _i OFFSET #0086
50	6,300 (78)					
55	6,300 (77.5)					
60	6,300 (76.5)			5,000 (78)		
65	6,300 (75)			5,000 (77.5)		
70	6,300 (73.5)	*6,100 (78)		5,000 (76)		
75	6,300 (72)	5,860 (77.5)		5,000 (74.5)	*4,900 (78)	
80	6,300 (70.5)	5,750 (76)	*5,000 (78)	5,000 (73.5)	4,900 (77.5)	
85	6,300 (69)	5,650 (74.5)	4,890 (77.5)	5,000 (72)	4,900 (76)	
90	6,300 (67.5)	5,550 (73)	4,820 (76)	4,900 (70.5)	4,900 (74.5)	*4,800 (78)
95	6,300 (66)	5,450 (71.5)	4,760 (74.5)	4,850 (69.5)	4,900 (73.5)	4,640 (76.5)
100	6,300 (64.5)	5,360 (70)	4,690 (73)	4,800 (68)	4,710 (72)	4,370 (75)
105	5,810 (63)	5,120 (68)	4,580 (71.5)	4,670 (66.5)	4,420 (70.5)	4,120 (73.5)
110	5,030 (61.5)	4,880 (66.5)	4,480 (69.5)	4,550 (65)	4,130 (69)	3,870 (72)
115	4,320 (59.5)	4,620 (65)	4,270 (68)	4,240 (63.5)	3,880 (67.5)	3,650 (70.5)
120	3,680 (58)	4,370 (63.5)	4,060 (66)	3,850 (62)	3,630 (66)	3,440 (69)
125	3,100 (56.5)	4,110 (61.5)	3,870 (64.5)	3,260 (60.5)	3,410 (64.5)	3,240 (67.5)
130	2,560 (54.5)	3,500 (60)	3,680 (62.5)	2,720 (59)	3,190 (63)	3,050 (65.5)
135	2,070 (53)	2,940 (58)	3,510 (60.5)	2,220 (57.5)	3,000 (61.5)	2,880 (64)
140	1,610 (51)	2,420 (56)	2,980 (58.5)	1,760 (56)	2,630 (60)	2,710 (62.5)
145	1,190 (49)	1,950 (54.5)	2,440 (56.5)	1,340 (54.5)	2,150 (58)	2,560 (60.5)
150		1,500 (52.5)	1,930 (54.5)		1,700 (56.5)	2,210 (58.5)
155		1,090 (50.5)	1,470 (52)		1,290 (54.5)	1,750 (57)
160			1,030 (50)			1,310 (55)
Minimum boom angle (i) for indicated length (no load)	48	49	49	52		53
Maximum boom length (ft.) at 0 _i boom angle (no load)		76.7			76.7	

NOTE: () Boom angles are in degrees. A6-829-103478

#LMI operating code. Refer to LMI manual for operating instructions.

*This capacity is based upon maximum boom angle.

NOTES:

1. All capacities above the bold line are based on structural strength of boom extension and do not exceed 85% of tipping loads, in accordance with SAE J-765.
2. The 56 ft. extension length may be used for single line lifting service only.
3. For main boom lengths less than 141.7 ft. with the boom extension erected, the rated loads are determined by boom angle. Use only the column which corresponds to the boom extension length and offset for which the machine is set up. For boom angles not shown, use rating of the next lower boom angle.
4. **WARNING:** Operation of this machine with heavier loads than the capacities listed is strictly prohibited. Machine tipping with boom extension occurs rapidly and without advance warning.
5. Boom angle is the angle above or below horizontal of the longitudinal axis of the boom base section after lifting rated load.
6. When lifting over the main boom nose with 56 ft. extension erected and inserts, the outriggers must be fully extended and vertical jacks set.

RT890E

THIS CHART IS ONLY A GUIDE AND SHOULD NOT BE USED TO OPERATE THE CRANE. The individual crane's load chart, operating instructions and other instructional plates must be read and understood prior to operating the crane.

GROVE

Courtesy of Crane.Market

load chart (Mode A)

 37.3 - 141.7 ft.
  22,000 lbs
  100% 24 ft. spread
  360...

Feet	37.3	50.4	63.4	76.4	89.4	102.4	115.4	141.7
10	180,000 (68.5)	134,000 (75)	*80,800 (78)					
12	156,000 (65)	134,000 (72.5)	80,800 (76.5)	*38,700 (78)				
15	128,500 (59.5)	129,000 (68.5)	80,800 (73.5)	38,700 (77)	*38,500 (78)			
20	98,650 (49.5)	98,950 (62)	70,950 (68.5)	38,700 (73)	38,500 (76.5)	*38,400 (78)		
25	78,800 (36.5)	79,150 (55)	62,300 (63.5)	38,700 (69)	38,500 (73)	38,400 (76)	24,400 (78)	
30	51,550 (12.5)	60,500 (47)	55,250 (58)	38,700 (65)	38,500 (69.5)	37,500 (73)	24,400 (76)	*24,400 (78)
35		45,150 (38)	44,900 (52.5)	38,700 (60.5)	36,750 (66)	33,150 (70)	24,400 (73.5)	24,400 (77)
40		35,250 (25.5)	34,700 (46)	36,750 (56)	32,750 (62)	29,550 (67)	24,400 (70.5)	24,250 (75)
45			27,600 (39)	29,450 (51)	29,400 (58.5)	26,500 (63.5)	24,400 (68)	21,900 (73)
50			22,400 (30)	24,000 (45.5)	25,650 (54.5)	23,950 (60.5)	22,050 (65)	19,800 (70.5)
55			18,250 (15.5)	19,850 (39.5)	21,350 (50)	21,750 (57)	20,000 (62)	17,900 (68.5)
60				16,600 (32.5)	17,950 (45.5)	18,900 (53.5)	18,250 (59)	16,150 (66)
65				13,850 (23)	15,200 (40)	16,150 (49.5)	16,700 (56)	14,650 (64)
70					12,950 (34.5)	13,850 (45.5)	14,800 (53)	12,850 (61.5)
75					11,000 (27.5)	11,950 (41)	12,900 (49.5)	10,950 (59)
80					9,340 (17)	10,300 (36)	11,250 (45.5)	9,380 (56.5)
85						8,900 (30)	9,830 (42)	7,980 (54)
90						7,640 (22.5)	8,590 (37.5)	6,770 (51)
95						6,520 (8)	7,510 (32.5)	5,700 (48.5)
100							6,520 (26.5)	4,750 (45.5)
105							5,640 (18.5)	3,910 (42)
110								3,150 (38.5)
115								2,460 (35)
120								1,840 (30.5)
125								1,250 (25.5)

13

Minimum boom angle (deg.) for indicated length (no load) 24
 Maximum boom length (ft.) at 0 deg. boom angle (no load) 115.4
 #LMI operating code. Refer to LMI manual for instructions.
 *This capacity is based upon maximum obtainable boom angle.
 Note: () Boom angles are in degrees.

Lifting Capacities at Zero Degree Boom Angle							
Boom Angle	Main Boom Length in Feet						
	37.3	50.4	63.4	76.4	89.4	102.4	115.4
0 _i	27,500 (30.1)	17,300 (43.2)	11,050 (56.2)	8,580 (69.2)	6,700 (82.2)	5,380 (95.2)	4,280 (108.2)

Note: () Reference radii in feet.

6-829-103320A

RT890E

THIS CHART IS ONLY A GUIDE AND SHOULD NOT BE USED TO OPERATE THE CRANE. The individual crane's load chart, operating instructions and other instructional plates must be read and understood prior to operating the crane.

GROVE.

Courtesy of Crane.Market

load charts (Mode A)

14

37.3-76.4 ft. 22,000 lbs Stationary 360...

Pounds				
Main Boom				
Feet	Main Boom Length in Feet			
	37.3	50.4	63.4	76.4
12	39,500 (65)	41,650 (72.5)	18,900 (73.5)	15,650 (77)
15	37,750 (59.5)	38,950 (68.5)	18,900 (73.5)	15,650 (73)
20	24,850 (49.5)	24,850 (62)	18,900 (68.5)	15,650 (69)
25	16,300 (36.5)	16,650 (55)	17,450 (63.5)	15,650 (65)
30	10,200 (12.5)	11,350 (47)	11,450 (58)	13,200 (65)
35		7,650 (38)	7,630 (52.5)	9,280 (60.5)
40		4,920 (25.5)	5,020 (46)	6,510 (56)
45				4,490 (51)
Minimum boom angle (i) for indicated length (no load)			39	46
Maximum boom length (ft.) at 0 _i boom angle (no load)			50.4	
Lifting Capacities at Zero Degree Boom Angle				
Boom Angle	Main Boom Length in Feet			
	37.3	50.4		
0 _i	10,050 (30.1)	3,150 (43.2)		

Note: () Reference radii in feet. A6-829-103452A
#LMI operating code. Refer to LMI manual for instructions.

37.3-76.4 ft. 22,000 lbs Pick & Carry Up to 2.5 mph Boom Centered Over Front

Pounds				
Main Boom				
Feet	Main Boom Length in Feet			
	37.3	50.4	63.4	76.4
12	41,600 (65)	41,700 (72.5)		
15	41,600 (59.5)	41,700 (68.5)	22,400 (73.5)	15,650 (77)
20	36,250 (49.5)	36,450 (62)	22,400 (68.5)	15,650 (73)
25	27,600 (36.5)	28,250 (55)	22,400 (63.5)	15,650 (69)
30	21,300 (12.5)	22,200 (47)	22,400 (58)	15,650 (65)
35		17,500 (38)	17,950 (52.5)	15,650 (60.5)
40		13,800 (25.5)	14,350 (46)	15,650 (56)
45			11,000 (39)	12,500 (51)
50			8,360 (30)	9,820 (45.5)
55			6,240 (15.5)	7,690 (39.5)
Minimum boom angle (i) for indicated length (no load)			36	
Maximum boom length (ft.) at 0 _i boom angle (no load)			63.4	
Lifting Capacities at Zero Degree Boom Angle				
Boom Angle	Main Boom Length in Feet			
	37.3	50.4	63.4	
0 _i	21,150 (30.1)	11,600 (43.2)	5,790 (56.2)	

#LMI operating code. Refer to LMI manual for instructions.

NOTES:

1. Capacities are in pounds and do not exceed 75% of tipping loads as determined by test in accordance with SAE J765.
2. Capacities are applicable to machines equipped with 29.5x25 (34 ply) General tires at 76 psi cold inflation pressure.
3. Capacities appearing above the bold line are based on structural strength and tipping should not be relied upon as a capacity limitation.
4. Capacities are applicable only with machine on firm level surface.
5. On rubber lifting with boom extensions not permitted.
6. For pick and carry operation, boom must be centered over front of machine, mechanical swing lock engaged and load restrained from swinging. When handling loads in the structural range with capacities close to maximum ratings, travel should be reduced to creep speeds.
7. Axle lockouts must be functioning when lifting on rubber.
8. All lifting depends on proper tire inflation, capacity and condition. Capacities must be reduced for lower tire inflation pressures. See lifting capacity chart for tire used. Damaged tires are hazardous to safe operation of crane.
9. Creep – not over 200 ft. of movement in any 30 minute period and not exceeding 1 mph.

RT890E

THIS CHART IS ONLY A GUIDE AND SHOULD NOT BE USED TO OPERATE THE CRANE. The individual crane's load chart, operating instructions and other instructional plates must be read and understood prior to operating the crane.

33-56 ft. luffing folding boom extension (mode B) (fixed offset angles)



Pounds						
Feet	33 ft. LENGTH			56 ft. LENGTH		
	5° OFFSET #0091	20° OFFSET #0091	40° OFFSET #0091	5° OFFSET #0092	20° OFFSET #0092	40° OFFSET #0092
40	*13,700 (78)					
45	13,700 (77)					
50	13,700 (75)	13,700 (77.5)		*8,200 (78)		
55	13,700 (73.5)	13,700 (75.5)	*11,000 (78)	8,200 (77.5)		
60	13,700 (71.5)	13,700 (74)	11,000 (76)	8,200 (76)		
65	13,700 (70)	12,850 (72)	10,950 (74.5)	8,200 (74.5)	8,200 (77.5)	
70	12,500 (68)	12,000 (70)	10,350 (72.5)	8,200 (73)	8,200 (76)	
75	11,350 (66)	11,200 (68)	9,830 (70.5)	8,200 (71.5)	8,100 (74)	6,400 (77.5)
80	9,730 (64.5)	10,450 (66.5)	9,330 (68.5)	8,200 (69.5)	7,600 (72.5)	6,400 (76)
85	8,300 (62.5)	8,980 (64.5)	8,860 (66.5)	8,200 (68)	7,150 (71)	6,230 (74)
90	7,060 (60.5)	7,660 (62.5)	8,210 (64.5)	7,740 (66.5)	6,730 (69)	5,920 (72.5)
95	5,960 (58.5)	6,500 (60.5)	6,980 (62)	7,130 (64.5)	6,350 (67.5)	5,640 (70.5)
100	4,990 (56.5)	5,470 (58)	5,880 (60)	6,130 (63)	6,000 (65.5)	5,380 (68.5)
105	4,120 (54)	4,560 (56)	4,900 (58)	5,230 (61)	5,690 (64)	5,140 (67)
110	3,340 (52)	3,730 (54)	4,020 (55.5)	4,430 (59.5)	5,290 (62)	4,900 (65)
115	2,640 (49.5)	2,990 (51.5)	3,230 (53)	3,700 (57.5)	4,490 (60)	4,690 (63)
120	2,000 (47.5)	2,320 (49)	2,510 (50.5)	3,040 (55.5)	3,760 (58.5)	4,470 (61)
125	1,420 (45)	1,700 (46.5)	1,850 (47.5)	2,440 (53.5)	3,100 (56.5)	3,710 (58.5)
130		1,140 (44)	1,250 (45)	1,900 (51.5)	2,500 (54.5)	3,030 (56.5)
135				1,390 (49.5)	1,940 (52)	2,390 (54)
140					1,420 (50)	1,810 (52)
145						1,270 (49)
Minimum boom angle (°) for indicated length (no load)	42	43	43	48	48	47
Maximum boom length (ft.) at 0° boom angle (no load)		89.8			76.7	

NOTE: () Boom angles are in degrees. A6-829-103522
 #LMI operating code. Refer to LMI manual for operating instructions.
 *This capacity is based upon maximum boom angle.

NOTES:

- All capacities above the bold line are based on structural strength of boom extension and do not exceed 85% of tipping loads, in accordance with SAE J-765.
- The 33 ft. luffing folding boom extension may be used for single or double line lifting service. The 56 ft. luffing folding boom extension may be used for single line lifting service only.
 WARNING: Lifting with the 33 ft. extension base, with the 23 ft. extension fly either erected or folded along side of extension base, is strictly prohibited.
- WARNING: Operation of this machine with heavier loads than the capacities listed is strictly prohibited. Machine tipping with boom extension occurs rapidly and without advance warning.
- Boom angle is the angle above or below horizontal of the longitudinal axis of the boom base section after lifting rated load.
- Capacities listed are with outriggers properly extended and vertical jacks set only.
- For main boom lengths less than 141.7 ft. with the boom extension erected, the rated loads are determined by boom angle. Use only the column which corresponds to the boom extension length and offset for which the machine is set up. For boom angles not shown, use rating of the next lower boom angle.
- When lifting over the main boom nose with 33 ft. or 56 ft. extension erected, the outriggers must be fully extended or 50% extended (17.3 ft. spread).

33-56 ft. luffing folding boom extension (mode B) (intermediate offset angles)



16

Feet	Pounds			
	33 ft. LENGTH		56 ft. LENGTH	
	5° - 20° OFFSET #0091	20° - 40° OFFSET	5° - 20° OFFSET	20° - 40° OFFSET #0092
50	11,850			
55	11,550	10,750		
60	11,200	10,600		
65	10,900	10,450	6,150	
70	10,650	10,350	5,960	
75	10,350	9,830	5,780	5,370
80	9,730	9,330	5,610	5,280
85	8,300	8,860	5,450	5,200
90	7,060	7,660	5,310	5,130
95	5,960	6,500	5,170	5,070
100	4,990	5,470	5,040	5,010
105	4,120	4,560	4,920	4,910
110	3,340	3,730	4,430	4,810
115	2,640	2,990	3,700	4,490
120	2,000	2,320	3,040	3,760
125	1,420	1,700	2,440	3,100
130		1,140	1,900	2,500
135			1,390	1,940
140				1,420
Min. boom angle for indicated length (no load)	43°	43°	48°	48°
Max. boom length at 5° boom angle (no load)	89.8 ft.		76.7 ft.	

#LMI operating code. Refer to LMI manual for operating instructions.

A6-829-103525A

NOTES:

1. All capacities above the bold line are based on structural strength of boom extension and do not exceed 85% of tipping loads, in accordance with SAE J-765.
2. The 33 ft. luffing folding boom extension may be used for single or double line lifting service. The 56 ft. luffing folding boom extension may be used for single line lifting service only.
WARNING: Lifting with the 33 ft. extension base, with the 23 ft. extension fly either erected or folded along side of extension base, is strictly prohibited.
3. WARNING: Operation of this machine with heavier loads than the capacities listed is strictly prohibited. Machine tipping with boom extension occurs rapidly and without advance warning.
4. The loads for luffing depend on the angle of the main boom, angle of the boom extension and dynamic working pressure of the luffing cylinder for the boom extension.
5. Capacities listed are with outriggers properly extended and vertical jacks set only.
6. When lifting over the main boom nose with 33 ft. or 56 ft. extension erected, the outriggers must be fully extended or 50% extended (17.3 ft. spread).

RT890E

33-56 ft. luffing folding boom extension w/inserts (mode B) (fixed offset angles)



Pounds						
Feet	72 ft. (56 ft. LENGTH + 1 INSERT)			88 ft. (56 ft. LENGTH + 2 INSERTS)		
	5° OFFSET #0095	20° OFFSET #0095	40° OFFSET #0095	5° OFFSET #1095	20° OFFSET #1095	40° OFFSET #1095
55	*6,400 (78)					
60	6,400 (77.5)					
65	6,400 (76)			*5,000 (78)		
70	6,400 (74.5)	*6,400 (78)		5,000 (77)		
75	6,400 (73.5)	6,400 (76.5)		5,000 (75.5)	*5,000 (78)	
80	6,400 (72)	6,400 (75)	*5,500 (78)	5,000 (74.5)	5,000 (76)	
85	6,400 (70.5)	6,040 (73.5)	5,420 (76)	5,000 (73)	5,000 (74.5)	*4,460 (78)
90	6,250 (69)	5,630 (72)	5,100 (74.5)	5,000 (71.5)	4,790 (73)	4,460 (76.5)
95	5,800 (67.5)	5,260 (70.5)	4,800 (73)	4,740 (70)	4,420 (71.5)	4,150 (75)
100	5,380 (66)	4,910 (69)	4,520 (71.5)	4,350 (69)	4,090 (70.5)	3,860 (73.5)
105	5,010 (64)	4,610 (67.5)	4,270 (69.5)	4,010 (67.5)	3,790 (69)	3,600 (72)
110	4,570 (62.5)	4,310 (65.5)	4,020 (68)	3,680 (66)	3,490 (67.5)	3,340 (70.5)
115	3,840 (61)	4,040 (64)	3,790 (66)	3,390 (64.5)	3,230 (66)	3,110 (69)
120	3,180 (59.5)	3,780 (62.5)	3,570 (64.5)	3,110 (63)	2,980 (64.5)	2,890 (67.5)
125	2,570 (57.5)	3,290 (60.5)	3,370 (62.5)	2,720 (61.5)	2,760 (63)	2,680 (66)
130	2,020 (56)	2,680 (59)	3,180 (60.5)	2,160 (60)	2,540 (61.5)	2,480 (64.5)
135	1,510 (54)	2,120 (57)	2,680 (59)	1,640 (58.5)	2,300 (59.5)	2,300 (62.5)
140	1,040 (52.5)	1,600 (55)	2,100 (57)	1,170 (57)	1,780 (58)	2,120 (61)
145		1,130 (53)	1,560 (54.5)		1,300 (56.5)	1,820 (59)
150			1,060 (52.5)			1,320 (57)
Minimum boom angle (°) for indicated length (no load)	51	52	51	56	55	56
Maximum boom length (ft.) at 0° boom angle (no load)		76.7			63.7	

NOTE: () Boom angles are in degrees. A6-829-103523
 #LMI operating code. Refer to LMI manual for operating instructions.
 *This capacity is based upon maximum boom angle.

NOTES:

1. All capacities above the bold line are based on structural strength of boom extension and do not exceed 85% of tipping loads, in accordance with SAE J-765.
2. The 56 ft. luffing folding boom extension may be used for single line lifting service only.
3. **WARNING:** Operation of this machine with heavier loads than the capacities listed is strictly prohibited. Machine tipping with boom extension occurs rapidly and without advance warning.
4. **WARNING:** Lifting with the 33 ft. extension base, with the 23 ft. extension fly either erected or folded along side of extension base, or with either one or two 16 ft. insert sections installed, is strictly prohibited.
5. For main boom lengths less than 141.7 ft. with the boom extension erected, the rated loads are determined by boom angle. Use only the column which corresponds to the boom extension length and offset for which the machine is set up. For boom angles not shown, use rating of the next lower boom angle.
6. When lifting over the main boom nose with the 56 ft. extension erected and inserts, the outriggers must be fully extended and vertical jacks set.

33-56 ft. luffing folding boom extension w/inserts (mode B) (intermediate offset angles)

 37.3-141.7 ft.
  33 - 56 ft.
  1 or 2 16 ft Inserts
  22,000 lbs
  100%
  360°
 34'-6" Spread

18

Feet	Pounds			
	72 ft. LENGTH (56 ft. + 1 INSERT)		88 ft. LENGTH (56 ft. + 2 INSERTS)	
	5° - 20° OFFSET	20° - 40° OFFSET	5° - 20° OFFSET	20° - 40° OFFSET
	#0095		#1095	
70	6,090			
75	5,920		5,000	
80	5,750	5,340	5,000	
85	5,600	5,260	5,000	4,460
90	5,460	5,100	4,790	4,460
95	5,260	4,800	4,420	4,150
100	4,910	4,520	4,090	3,860
105	4,610	4,270	3,790	3,600
110	4,310	4,020	3,490	3,340
115	3,840	3,790	3,230	3,110
120	3,180	3,570	2,980	2,890
125	2,570	3,290	2,720	2,680
130	2,020	2,680	2,160	2,480
135	1,510	2,120	1,640	2,300
140	1,040	1,600	1,170	1,780
145		1,130		1,300
Min. boom angle for indicated length (no load)	52°	52°	56°	56°
Max. boom length at 5° boom angle (no load)	76.7 ft.		63.7 ft.	

NOTES:

1. All capacities above the bold line are based on structural strength of boom extension and do not exceed 85% of tipping loads, in accordance with SAE J-765.
2. The 56 ft. luffing folding boom extension may be used for single line lifting service only
WARNING: Lifting with the 33 ft. extension base, with the 23 ft. extension fly either erected or folded along side of extension base, or with either one or two 16 ft. insert sections installed, is strictly prohibited.
3. **WARNING:** Operation of this machine with heavier loads than the capacities listed is strictly prohibited. Machine tipping with boom extension occurs rapidly and without advance warning.
4. The loads for luffing depend on the angle of the main boom, angle of the boom extension and dynamic working pressure of the luffing cylinder for the boom extension.
5. When lifting over the main boom nose with 56 ft. extension erected and inserts, the outriggers must be fully extended and vertical jacks set only.

#LMI operating code. Refer to LMI manual for operating instructions. A6-829-103526

RT890E

GROVE.

load handling

19

Weight Reductions for Load Handling Devices

33 ft.-56 ft. Folding Boom Extension	
*33 ft. Extension (Erected)	3,750 lb.
*56 ft. Extension (Erected)	8,000 lb.
*72 ft. (1 insert Erected)	10,450 lb.
*88 ft. (2 inserts Erected)	13,000 lb.

*Reduction of main boom capacities
(no deduct required for stowed boom extension)

Auxiliary Boom Nose	133 lb.
Hookblocks and Headache Balls:	
80 Ton, 5 Sheave	1,600 lb. +
90 Ton, 5 Sheave	1,300 lb. +
10 Ton Overhaul Ball	568 lb. +
+ Refer to rating plate for actual weight.	

When lifting over swingaway and/or jib combinations, deduct total weight of all load handling devices reeved over main boom nose directly from swingaway or jib capacity.

NOTE: All load handling devices and boom attachments are considered part of the load and suitable allowances **MUST BE MADE** for their combined weights. Weights are for Grove furnished equipment.

Line Pulls and Reeving Information

Hoists	Cable Specs	Permissible Line Pulls	Nominal Cable Length
Main	3/4" (19 mm) 6x37 Class, EIPS, IWRC Special Flexible Min. Breaking Str. 58,800 lb.	16,800 lb.	600 ft.
Main & Aux.	3/4" (19 mm) Flex-X 35 Rotation Resistant (non-rotating) Min. Breaking Strength 85,800 lb.	16,800 lb.	600 ft.

The approximate weight of 3/4" wire rope is 1.5 lb./ft.

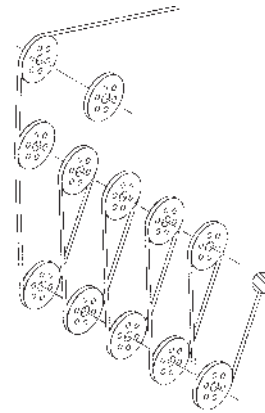

Installation and Removal of Counterweight and Auxiliary Hoist

Rated lifting capacities in pounds on outriggers fully extended –

Radius In Feet	LMI Code #0801 Main Boom Length
	37.3 ft*
10	24,000
12	24,000
15	24,000
20	24,000
25	24,000
30	24,000

*The boom must be fully retracted.

A6-829-103450

Hoist Performance

Wire Rope Layer	Hoist Line Pulls Two Speed Hoist		Drum Rope Capacity (ft.) 15 in. Drum	
	Low Available lb.*	High Available lb.*	Layer	Total
1	20,250	9,610	101	101
2	18,490	8,770	110	211
3	17,010	8,070	120	331
4	15,750	7,470	129	460
5	14,660	6,960	139	599

*Max. lifting capacity: 6x37 or 35x7 class = 16,800 lb.

Working Area Diagram

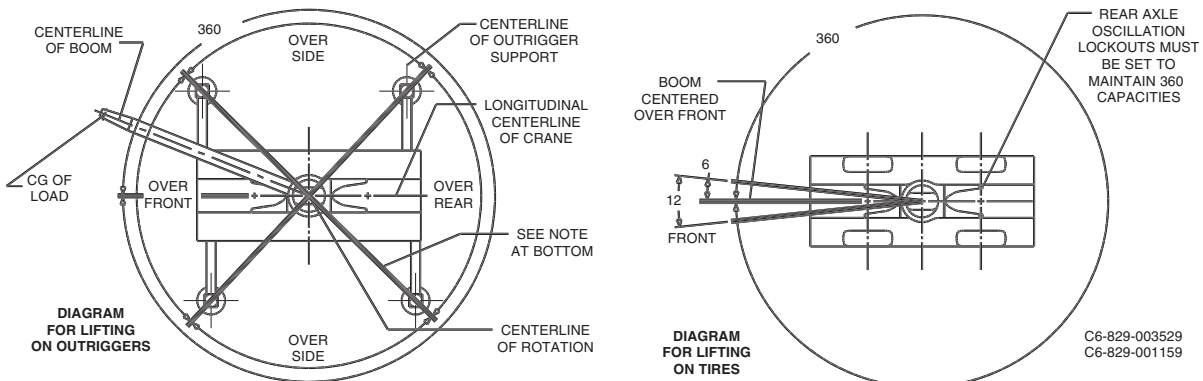

Bold lines determine the limiting position of any load for operation within working areas indicated.

THIS CHART IS ONLY A GUIDE AND SHOULD NOT BE USED TO OPERATE THE CRANE. The individual crane's load chart, operating instructions and other instructional plates must be read and understood prior to operating the crane.

GROVE.

Courtesy of Crane.Market

RT890E