



**Access like never before:**

- Hydraulic outriggers and automatic leveling allow operation in under 30 seconds
- High performance 4-wheel drive and this machine's light weight provide access to places larger and heavier self-propelled machines can not go
- Easily transported on a trailer with no commercial driver's license required
- Dual power source (DC / Gas) allows for use indoors / outdoors

**Features for optimum performance:**

- 4,500 watt generator
- Air and water lines and 110 V GFI protected outlets to platform

45 XA - 500 lb / 2x 55 XA - 500 lb / 2x

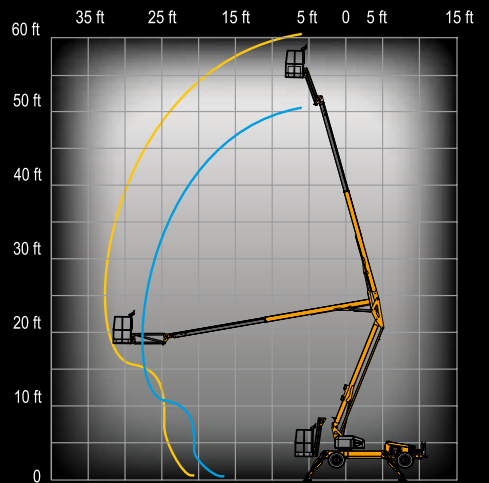

[www.haulotte-usa.com](http://www.haulotte-usa.com)

**Haulotte** **GROUP**  
More Than Lifting

# 45 XA / 55 XA

Lightweight self-propelled booms

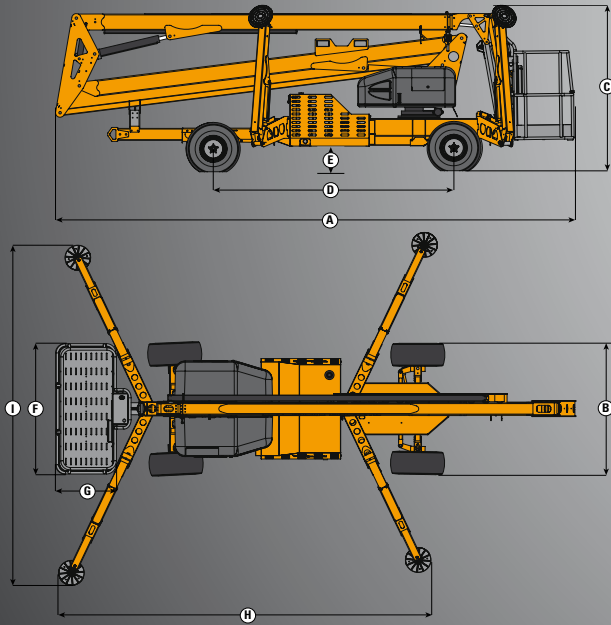

## TECHNICAL DATA

**45 XA**

**55 XA**

Working height	51 ft	61 ft 3 in
Platform height	45 ft	55 ft 3 in
Horizontal outreach (from centerline)	27 ft	33 ft 5 in
Horizontal outreach (from edge of footpad)	21 ft	27 ft 4 in
Up and over height	20 ft 9 in	23 ft 1 in
Lift capacity	500 lb	
A - Length - stowed	18 ft 3 in	21 ft 2 in
B - Width stowed	5 ft 6 in	5 ft 8 in
C - Height stowed	6 ft 6 in	
D - Wheelbase	8 ft 9 in	10 ft 1 in
E - Ground clearance	9 in	
F x G - Platform size	5 ft x 2 ft 6 in	
H x I - Outrigger footprint	12 ft 2 in x 11 ft 4 in	12 ft 11 in x 12 ft 9 in
Turntable rotation	700 ° non-continuous	
Jib - length	4 ft 3 in	4 ft 3 in
Jib - Vertical motion	150 ° (+70 / -80)	
Drive speed	3.5 mph (max)	4.5 mph (max)
Gradeability	48%	45%
Turning radius - inside	10 ft	7 ft
Turning radius - outside	17 ft 6 in	12 ft 7 in
Tire size	26 x 12 Bar lug	
Batteries	4 x 6V 245 Amp-hr	
Engine	21 hp gas Kawasaki OR 15 hp diesel Hatz	31 hp gas Kubota OR 21 hp diesel Kubota
Weight	4,715 lb	6,000 lb

## STANDARD EQUIPMENT

- Hydraulic outriggers
- Automatic leveling system
- Self-leveling platform
- Air line to platform
- Water line to platform
- 110 V GFI protected outlet to platform and base
- 4,500 watt generator
- Hour meter
- Battery condition indicator
- Dual power system
- Easy to use controls with logically positioned buttons
- Tilt alarm/sensor
- Spring applied hydraulic released breaks
- Inboard 40 amp charger
- Bar-lug tires
- 4-wheel steering (55 XA only)

## OPTIONS & ACCESSORIES

- Material lifting hook
- Platform rotator (manual)
- Operational warning light (flashing beacon)
- Fluorescent tube caddy
- Tool tray
- Tire options (turf, non-marking, foam filled)
- Dual fuel - 31 hp gas / liquid propane Kubota (55 XA only)



**Haulotte**   
GROUP