



HA46 RTJ 0

Performance & ease of use

- Industry leading working envelope with an outreach of 27 ft 3 in
- Best lifting speed of 40 seconds
- Fully proportional and simultaneous movements
- Ease of transport

Excellent Robustness

- Rugged hoods with ergonomic handle
- Long lasting structural design

Easy Maintenance

- Fully modular basket with upper control box cover
- Easy access to all components
- ACTIV'Screen diagnostic display for fault and service alerts

Best Comfort and Safety Feeling

- Safe driving



Haulotte 



HA46 RTJ 0

ROUGH TERRAIN ARTICULATING BOOMS

TECHNICAL DATA

HA46 RTJ 0

4WD / 2WS

Front oscillating axle

Working height	51 ft 11 in
Platform height	45 ft 11 in
Horizontal outreach	27 ft 3 in
Up and over height	25 ft 1 in
Lift capacity	500 lbs
F x G Platform size	95 in x 34.5 in
A Length	22 ft 2 in
H Transport length (jib tucked under)	16 ft 7 in
B Width	7 ft 7 in
C Height - stowed	7 ft 7 in
I Transport height	7 ft 10 in
Vertical jib rotation	140° (-80°/+60°)
Platform rotation	165° (-75°/+90°)
Turntable rotation	355° non continuous
D Wheelbase	6 ft 11 in
E Ground clearance	15 in
Tilt alarm	5°
Drive speed	3.2 mph
Gradeability	40 %
Turning radius - outside	14 ft 9 in
Tires Cured on solid rough terrain	14x17.5
Engine	Kubota 26kW - 35 hp
Hydraulic tank capacity	20.1 gal
Fuel tank capacity	16.4 gal
Weight	14,222 lbs

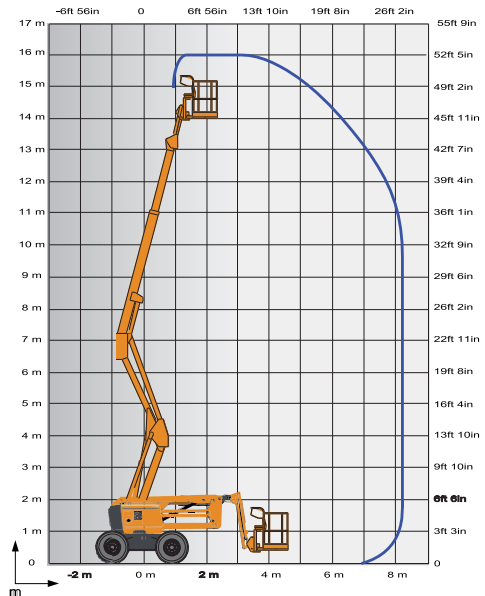

STANDARD EQUIPMENT

- 4 wheel drive
- 2 wheel steer
- Front oscillating axle increases stability on uneven ground
- Permanent limited slip differential
- 500 lbs (2 persons) load capacity
- 4 simultaneous movements
- Safe to use in winds up to 37 mph
- Rotating beacon
- Modular standard basket 95 in x 34.5 quick & easy to repair
- Drop bar entry gate
- Upper control box cover
- Tool tray
- AC power to platform (110/230V)
- Embedded diagnostic system Haulotte Activ'Screen on lower control box
- Rotating engine tray for easy maintenance
- Hourmeter
- Low fuel level indicator (upper & lower control boxes)
- Engine pre-heater with light indicator
- Tilt / load alarm and light
- 12 V battery / electrical control system
- Electric pump system and emergency descent
- Travel alarm

OPTIONS AND ACCESSORIES

- Modular large basket 95 in x 34.5 in quick and easy to repair
- Lateral swing door entry gate
- Hydraulic generator Dynaset 3.5Kw
- Air-line to platform 0.2 inch inner diameter
- Power to platform (Female plug in the basket with or without circuit-breaker 30mA)
- Working light
- Cold weather kit : 14°F / -13°F
- Hot weather kit : hydraulic oil cooler + hydraulic oil
- Biodegradable hydraulic oil
- Large cured on solid rough terrain tires 385/65
- Non-marking tires 14x17.5
- Haulotte Activ'Shield© Bar : Exclusive secondary guarding device
- Catalytic exhaust for diesel engine
- Spark arrester and electric one-way valve
- Battery cut-off

