



## Performance & ease of use

- Best lifting speed of 48 seconds
- Industry leading working envelope and outreach
- Fully proportional and simultaneous movements
- Easy transport

## Excellent durability

- Rugged hoods with ergonomic handle
- Long lasting structural design

## Easy maintenance

- Modular basket with upper control box cover and tool tray
- Easy access to all components
- Self-diagnosis tool integrated on the lower control box

## Reliable and safe

- Optional Haulotte Activ'Shield™ Bar

**Haulotte**



# HA61 RTJ PRO

ROUGH TERRAIN ARTICULATING BOOMS



## TECHNICAL DATA

## HA61 RTJ PRO

Working height	67 ft 7 in
Platform height	61 ft
Horizontal outreach	40 ft
Up and over height	27 ft 7 in
Lift capacity	500 lbs
<b>F x G</b> Platform size	6 ft x 2 ft 7 in
<b>A</b> Length	28 ft 10 in
<b>B</b> Width	7 ft 11 in
Height - stowed	8 ft 3 in
<b>H</b> Transport length	21 ft 4 in
<b>C</b> Transport height	9 ft 7 in
Vertical jib rotation	140° (+60°/-80°)
Platform rotation	180° (+90°/-90°)
Turntable rotation	360° continuous
Tailswing	5.6 in
<b>D</b> Wheelbase	8 ft
<b>E</b> Ground clearance	16 in
Tilt alarm	5 °
Drive speed	0.3 - 3.1 mph
Gradeability	45 %
Tires - solid rough terrain	385/65-22.5
Turning radius - outside	9 ft 10 in
Engine	Kubota 37.4 kW – 50.1 hp Tier 4
Weight	21,165 lbs

## STANDARD EQUIPMENT

- 4 wheel drive, 4 wheel steer
- Front oscillating axle increases stability on uneven ground
- Lateral swing door entry gate
- 4 simultaneous movements
- 500 lb (2 person) load capacity
- Permanent limited slip differential
- Flashing beacon
- Fully modular large basket
- Upper control box protection cover and tool tray in ultra-solid plastic
- AC power to platform
- Self-diagnosis tool on lower control box
- Swing out engine tray for easy maintenance
- Hourmeter
- Low fuel level indicator (upper & lower control boxes)
- Tilt / load alarm and light
- 12 V battery
- Electric pump system and emergency descent
- Travel alarm
- Haulotte Activ'Shield™ Bar (Optional in North America)

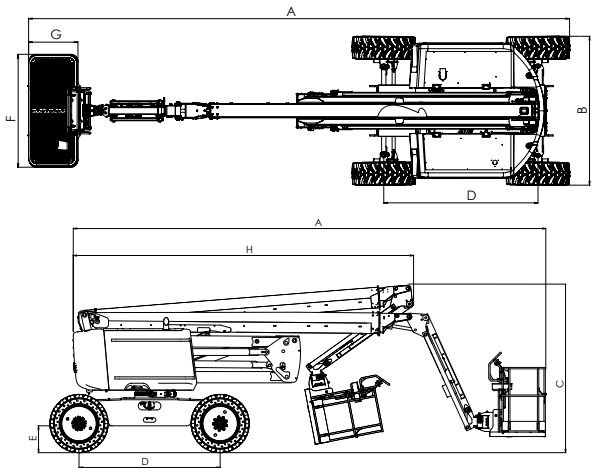
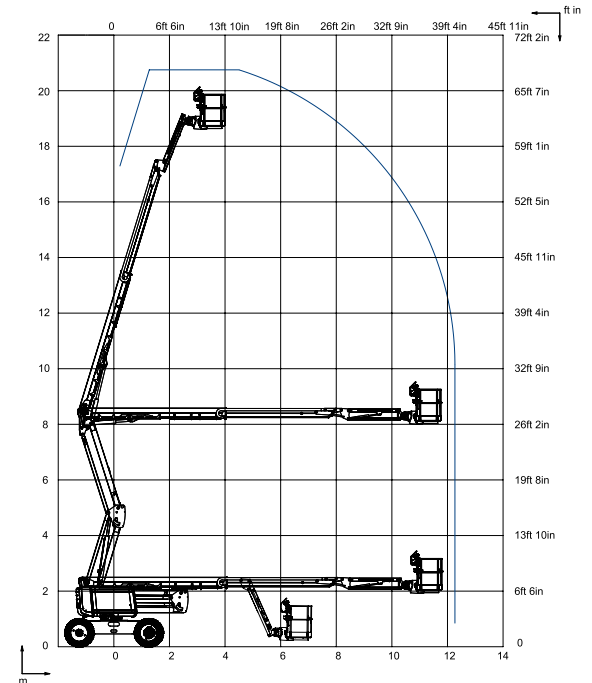

## OPTIONS AND ACCESSORIES

- Narrow platform
- Lateral swing door entry gate (Standard on US machines)
- Hydraulic generator Dynaset 3.5 kW or 12 kW
- Air line to platform
- 55 W working light
- Power to platform (standard on US machines)
- Flashing beacon
- Cold weather kit
- Warm environment kit
- Biodegradable hydraulic oil
- Non-marking tires
- Spark arrestor and electric one-way valve
- Welder and welder support
- Haulotte Activ'Shield™ Bar

4000417720 - Non-contractual document - We reserve the right to modify the technical characteristics of this document without notice - 09/2016