



### Safety first

- Double "lambo" doors, dedicated anti-slip steps and walkable plinths
- Picking tray with foldable side panels & front guard rail
- High-precision driving & smoothness with maximal driving visibility
- Quick machine with mobile pothole protections

### Go everywhere, anytime

- Maximum load of electric picking tray: 80 kg
- Intuitive upper control box with battery level indicator
- Smart transportability & lifting

### With the best value for money

- 3-stage-cylinder mast: no chain and no cable
- Direct electric drive (free maintenance) AC motors
- Easy access to components (2 swing out trays)
- Haulotte Activ'Screen (onboard diagnostic)

**Haulotte**



# STAR 6 PICKING



## VERTICAL MASTS

### TECHNICAL DATA

### STAR 6 PICKING

Working height	5.8 m
Platform height	3.8 m
Lift capacity	210 kg
Platform size	0.76 x 0,92 m
Picking tray size	0.74 x 0.50 m
Picking tray lift capacity	80 kg
<b>A</b> Length	1.65 m
<b>B</b> Width	0.79 m
<b>C</b> Height - stowed	1.75 m
<b>D</b> Wheelbase	1.07 m
<b>E</b> Ground clearance	6 cm
Drive speed proportional	0.8 - 4.5 km/h
Turning radius - outside	1.7 m
Tilt alarm	1.5 ° / 3 °
Gradeability	25 %
Driveable at full height up to	3.8 m
Hydraulic system capacity	8 l
Tires - non marking	318 x 108 mm
Power source	6V - 180 Ah (C5)
Weight	890 kg

### STANDARD EQUIPMENT

- Electric picking tray with foldable side panels & front guard rail
- 24 V electric drive brushless AC motors (free maintenance)
- 4 x 6V - 180 Ah batteries
- 30 A battery charger
- Battery level indicator
- Haulotte ACTIV'Screen
- Fork lifting pockets
- Hoisting and lifting points
- Electric brake release
- 2 "lambo" doors
- Walkable protection plinths
- Mobile potholes
- 2 front steering wheels
- 2 rear driving wheels
- Non marking tires
- Hourmeter
- Horn
- Travel alarm
- Flashing light
- Emergency stop
- Lowering system
- 2 upper control boxes (one is mobile)
- Control boxes at cage and ground level
- Towing hook

### OPTIONS AND ACCESSORIES

- Double flashing light
- Pedestrian warning light
- Order/stock picker equipment
- Biodegradable oil
- Hydraulic oil for cold conditions

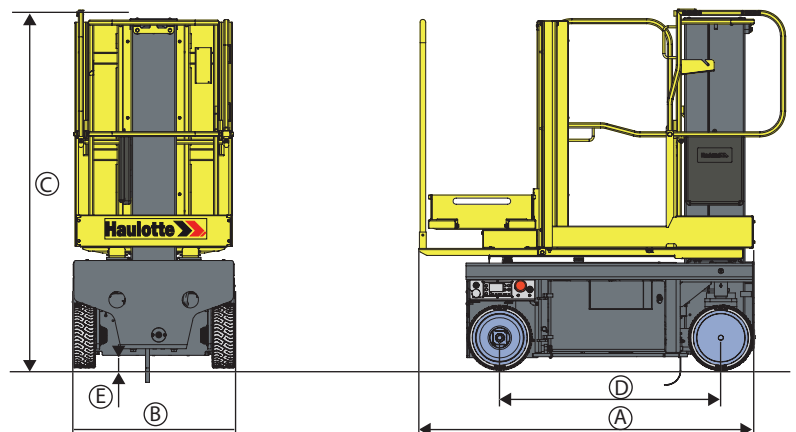
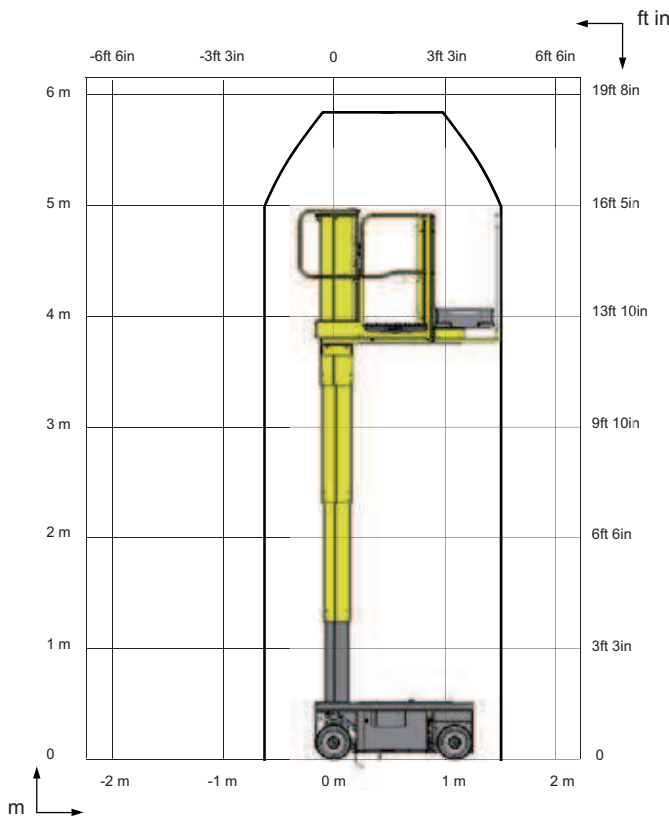

2420342590 - Non contractual document - We reserve the right to modify the technical characteristics of this document without notice - 03/2016

