

HIAB 055 Range 4-6 tm

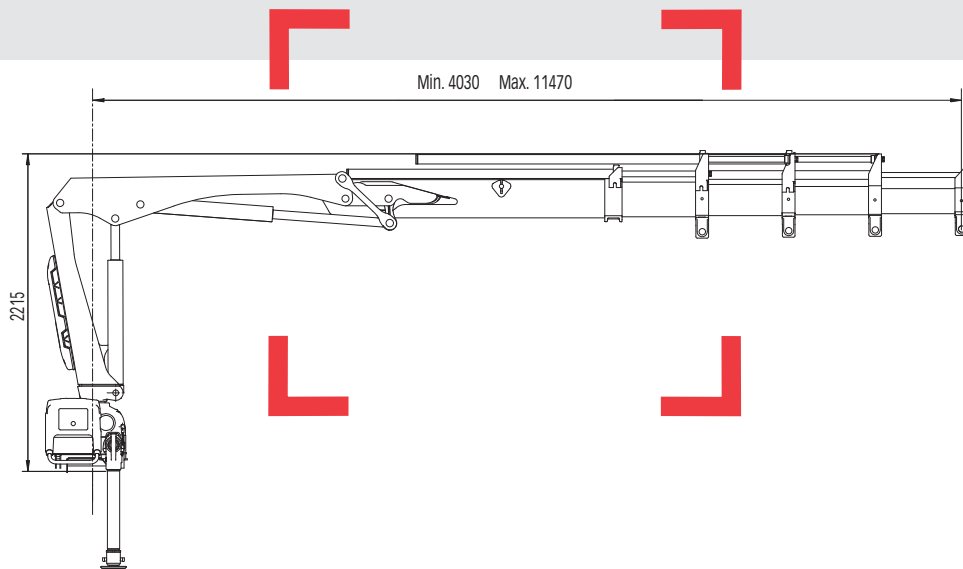

Technical data

Contents

Introduction	3
Safety Regulations	4
Disclaimer	4
Explanation of Symbols	4
Explanation of Diagrams	4
Specific Technical Data	7
HIAB XS 055 B CL	8-11
HIAB XS 055 B-1 CL.....	8
HIAB XS 055 B-2 CL.....	10
HIAB XS 055 BS CL	12-15
HIAB XS 055 BS-1 CL.....	12
HIAB XS 055 BS-2 CL.....	14
HIAB XS 055 B Duo	16-19
HIAB XS 055 B-1 Duo	16
HIAB XS 055 B-2 Duo	18
HIAB XS 055 BS Duo	20-23
HIAB XS 055 BS-1 Duo	20
HIAB XS 055 BS-2 Duo	22
HIAB XS 055 B HiDuo	24-27
HIAB XS 055 B-1 HiDuo.....	24
HIAB XS 055 B-2 HiDuo.....	26
HIAB XS 055 BS HiDuo	28-31
HIAB XS 055 BS-1 HiDuo.....	28
HIAB XS 055 BS-2 HiDuo.....	30
HIAB XS 055 D CL	32-39
HIAB XS 055 D-1 CL	32
HIAB XS 055 D-2 CL	34
HIAB XS 055 D-3 CL	36
HIAB XS 055 D-4 CL	38
HIAB XS 055 DS CL	40-47
HIAB XS 055 DS-1 CL	40
HIAB XS 055 DS-2 CL	42
HIAB XS 055 DS-3 CL	44
HIAB XS 055 DS-4 CL	46
HIAB XS 055 D Duo	48-55
HIAB XS 055 D-1 Duo.....	48
HIAB XS 055 D-2 Duo.....	50
HIAB XS 055 D-3 Duo.....	52
HIAB XS 055 D-4 Duo.....	54
HIAB XS 055 DS Duo	56-63
HIAB XS 055 DS-1 Duo.....	56
HIAB XS 055 DS-2 Duo.....	58
HIAB XS 055 DS-3 Duo.....	60
HIAB XS 055 DS-4 Duo.....	62

HIAB XS 055 D HiDuo	64-71
HIAB XS 055 D-1 HiDuo	64
HIAB XS 055 D-2 HiDuo	66
HIAB XS 055 D-3 HiDuo	68
HIAB XS 055 D-4 HiDuo	70
HIAB XS 055 DS HiDuo	72-79
HIAB XS 055 DS-1 HiDuo	72
HIAB XS 055 DS-2 HiDuo	74
HIAB XS 055 DS-3 HiDuo	76
HIAB XS 055 DS-4 HiDuo	78
General Technical Data	81
Table of Measurements	85

Introduction

Safety Regulations

All Technical Data are valid if the User Manual Instructions are followed.

Disclaimer

Hiab cranes have been built to meet the highest standards of safety and service life and have been thoroughly tested. Strength calculations for this model have been carried out in accordance with EN13001. Hiab's certified Quality Assurance System complies with the ISO 9001. Some of the items in our literature may be extra equipment. Certain applications may require an official permit. We reserve the right to change technical specifications without prior notice. Hiab cranes produced for EU-countries are CE-marked and comply with the European Standard EN12999.

Explanation of Symbols



Explanation of Diagrams

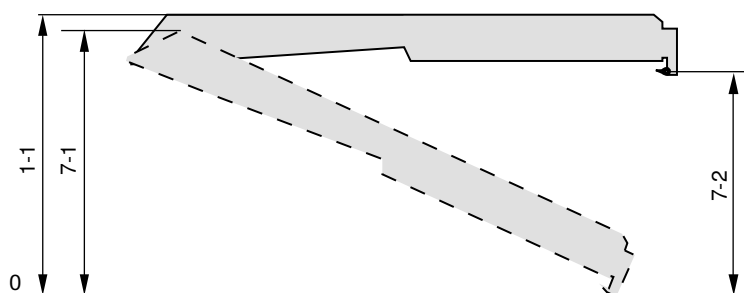

Note: Crane models with X-angle on outer boom show more cases.

Height Stretched Diagram

This diagram indicates the height of the crane in two cases:
 I Outer boom maximum upward and horizontal
 II Outer boom maximum upward and hook attachment in line with theoretical "zero", the crane base's bottom side.

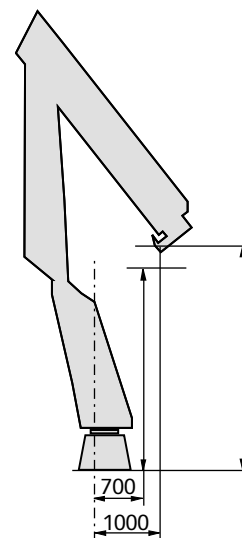

Side View Unfolded Close in Area

This drawing indicates the lifting height at 700 mm and 1000 mm from the heart of the crane column.

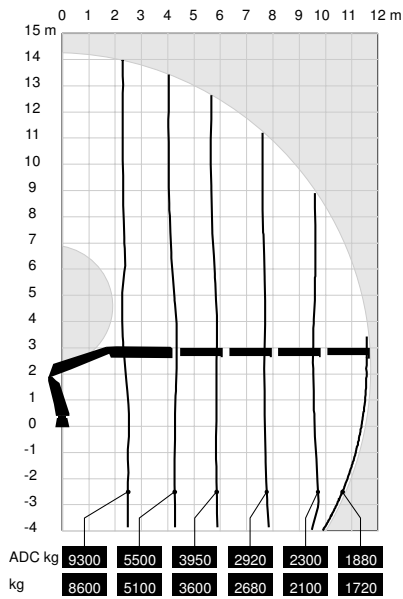

Load Diagram

To the left of the curve the indicated loads can be handled with any loader function provided that the positions of the booms are optimized from a force point of view.

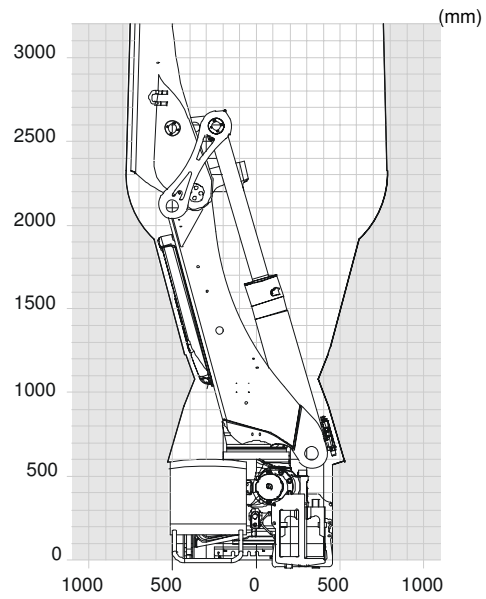

Rotation Diagram

The white silhouette indicates the required space when rotating the crane body. Please note that hydraulic hoses are excluded from the diagram.

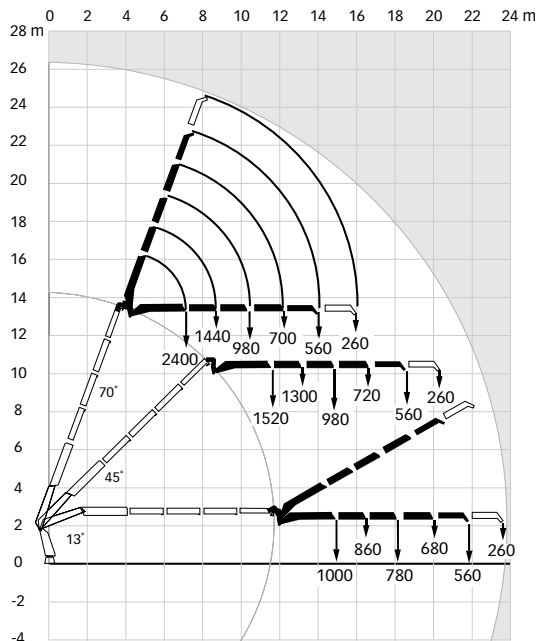

Load Diagram with Jib

This diagram shows the lifting capacity of the Jib in different boom positions.

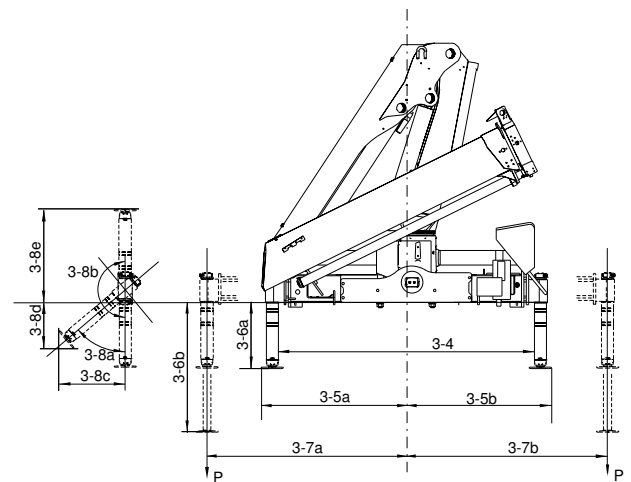

Specific values for stabilizer legs

This drawing shows the dimensions and measurements for the stabilizer legs. To find a configuration of stabilizer legs that match your application first choose a configuration of your choice in **Stabilizer Configuration**. Second, find the measurements in **Dimensions & Measurements**.

Specific Technical Data

Side View Unfolded Stretched

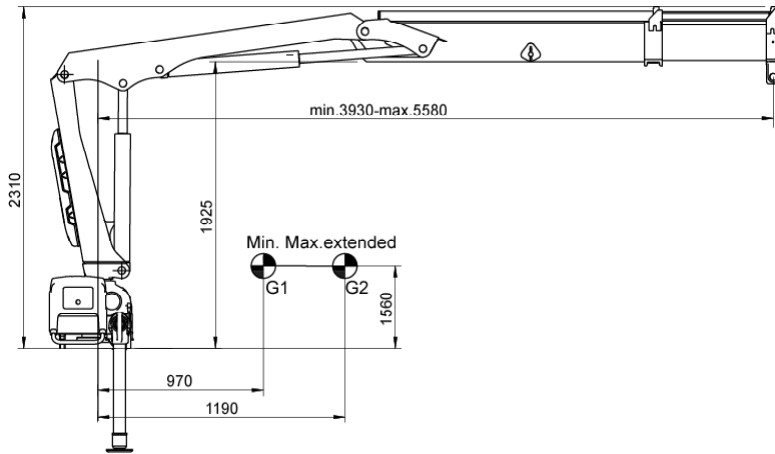

Side View Folded

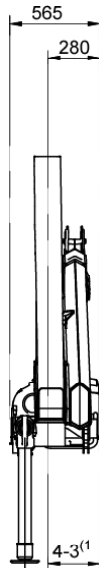

Front View Folded

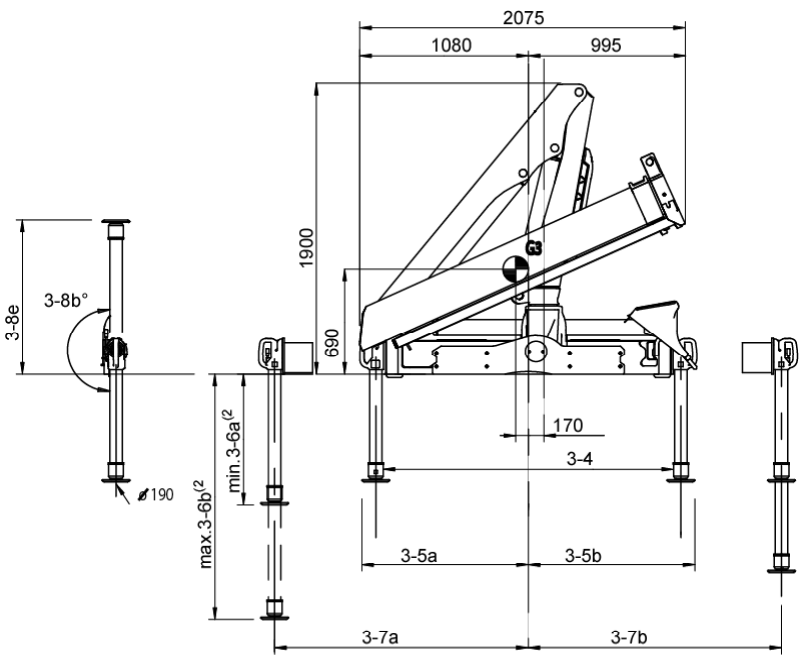

NOTE For specific values, see Table of Measurements

Top View Crane Base

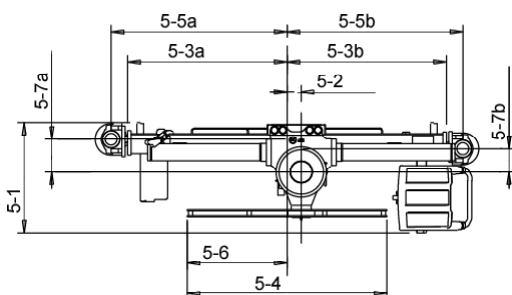

NOTE For specific values, see Table of Measurements

Chassis Installation

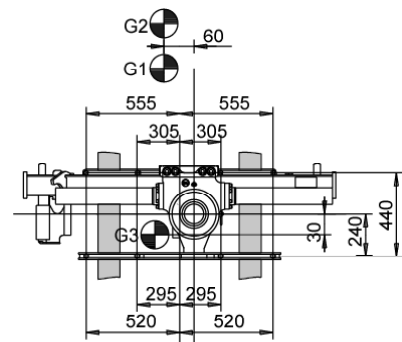

(1) Variable value depending on option
 (2) Variations may occur depending on mounting position.

Load Diagram

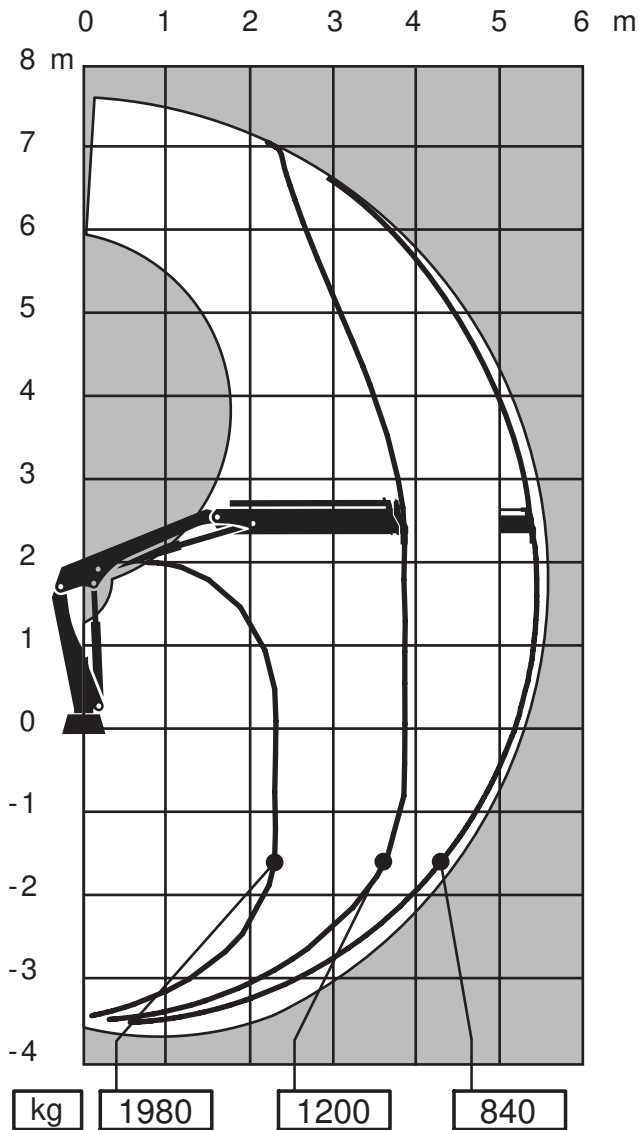

Capacity and performance

Lifting capacity	45 (kNm)
Standard lifting capacity at standard outreach	2.3 (m) - 1980 (kg)
	3.8 (m) - 1200 (kg)
	5.4 (m) - 840 (kg)
Manual lifting capacity at extension	7.2 (m) - 580 (kg)
	9.1 (m) - 420 (kg)
Hydraulic boom extension	1.7 (m)
Lifting height above installation level hydraulic	7.7 (m)
Slewing torque	7.7 (kNm)
V80 Slewing speed	15 (°/s)
Slewing angle	410 (°)
Lifting speed	1.0 (m/s)

Functional demands

Recommended oilflow low	25 (l/min)
Recommended oilflow high	30 (l/min)
Working pressure	22 (MPa)
Max slope viable at full capacity	5 (°)
Oil in tank	35 (l)
Tank capacity	40 (l)

Weights and measurements

Height in folded position	1900 (mm)
Width in folded position	2075 (mm)
Installation space needed	565 (mm)
Weight of crane	730 (kg)
Weight control stations (platform & top seat)	30 (kg)
Weight hose- and pipe kit	30 (kg)

Side View Unfolded Close in Area

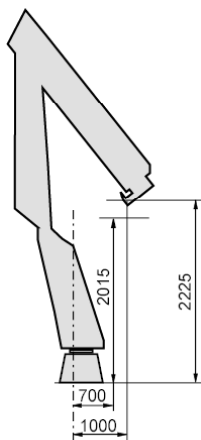

Side View Unfolded Stretched

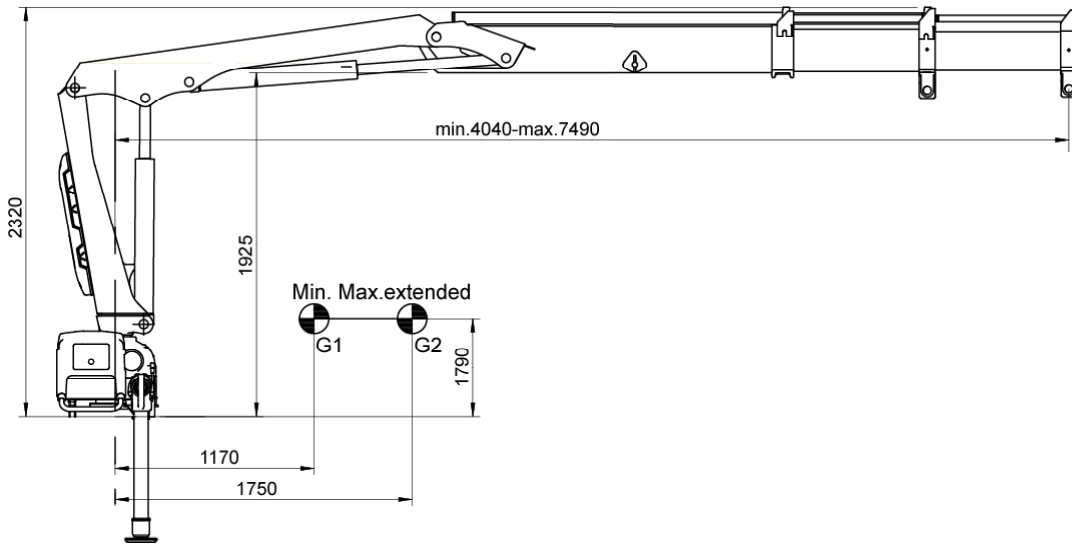

Side View Folded

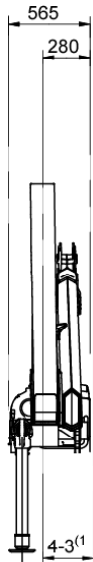

Front View Folded

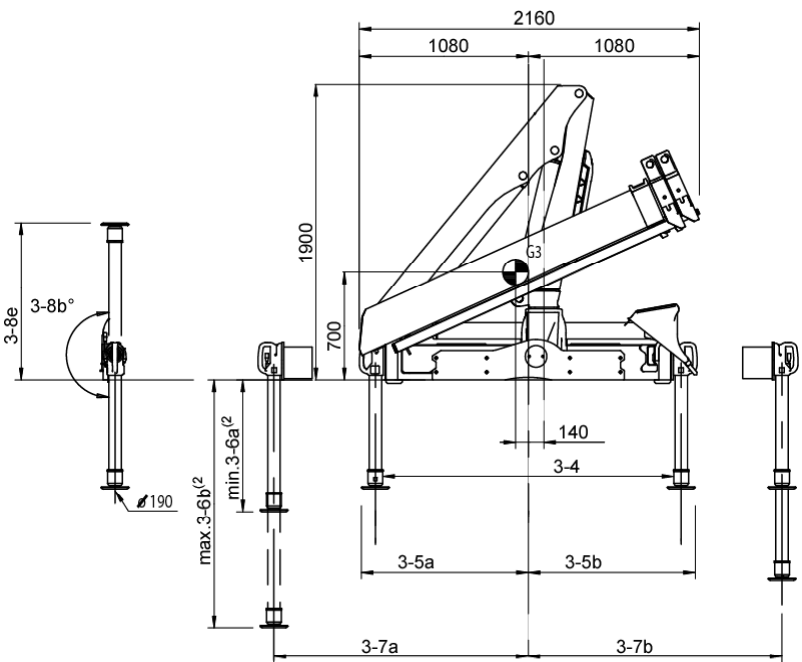

NOTE For specific values, see Table of Measurements

Top View Crane Base

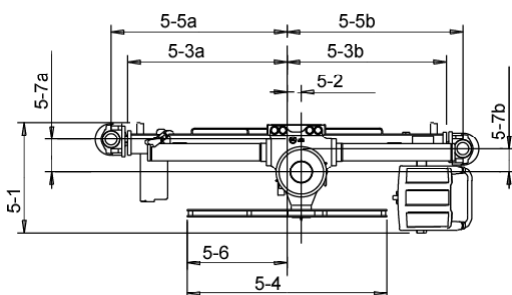

NOTE For specific values, see Table of Measurements

Chassis Installation

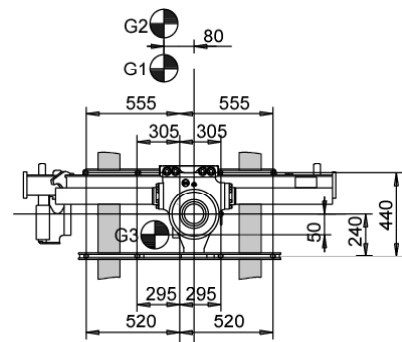

(1) Variable value depending on option.
 (2) Variations may occur depending on mounting position.

Load Diagram

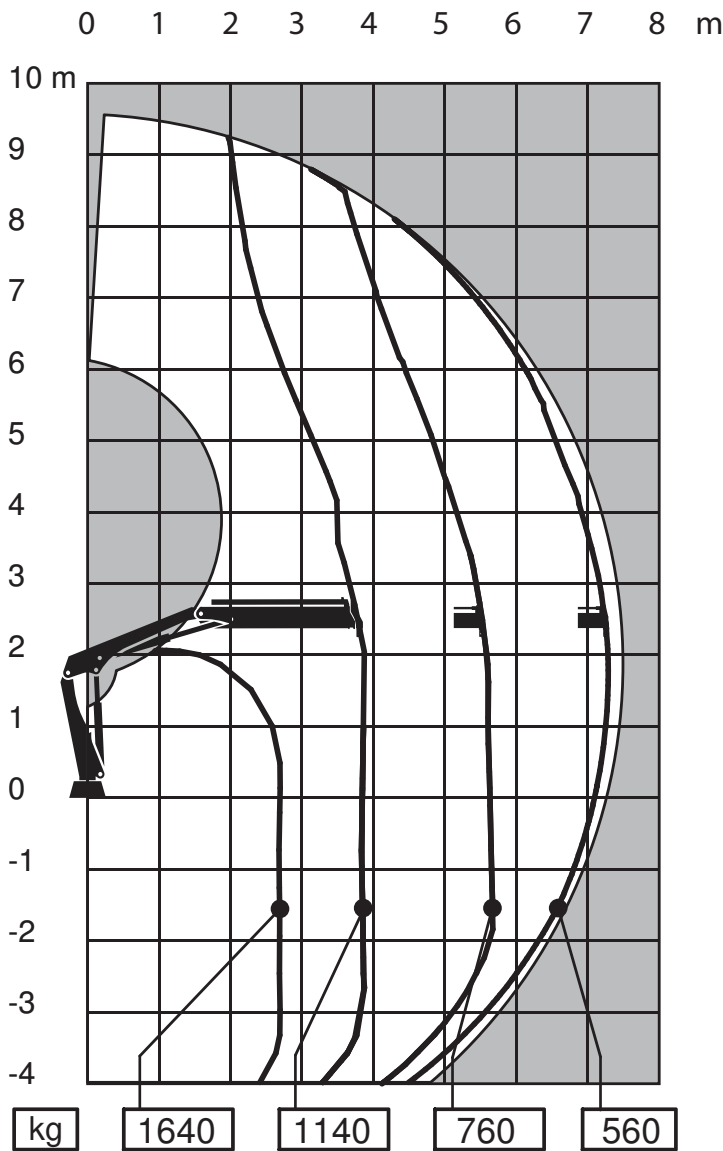

Side View Unfolded Close in Area

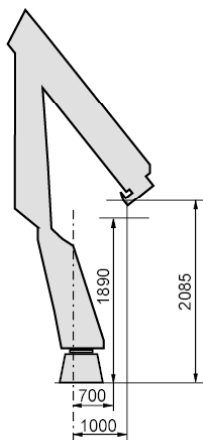

Capacity and performance

Lifting capacity	42 (kNm)
Standard lifting capacity at standard outreach	2.7 (m) - 1640 (kg)
	3.8 (m) - 1140 (kg)
	5.4 (m) - 760 (kg)
	7.2 (m) - 560 (kg)
Manual lifting capacity at extension	9.1 (m) - 400 (kg)
Hydraulic boom extension	3.5 (m)
Lifting height above installation level hydraulic	9.6 (m)
Slewing torque	7.7 (kNm)
V80 Slewing speed	15 (°/s)
Slewing angle	410 (°)
Lifting speed	1.4 (m/s)

Functional demands

Recommended oilflow low	25 (l/min)
Recommended oilflow high	30 (l/min)
Working pressure	22 (MPa)
Max slope viable at full capacity	5 (°)
Oil in tank	35 (l)
Tank capacity	40 (l)

Weights and measurements

Height in folded position	1900 (mm)
Width in folded position	2160 (mm)
Installation space needed	565 (mm)
Weight of crane	810 (kg)
Weight control stations (platform & top seat)	30 (kg)
Weight hose- and pipe kit	35 (kg)

Side View Unfolded Stretched

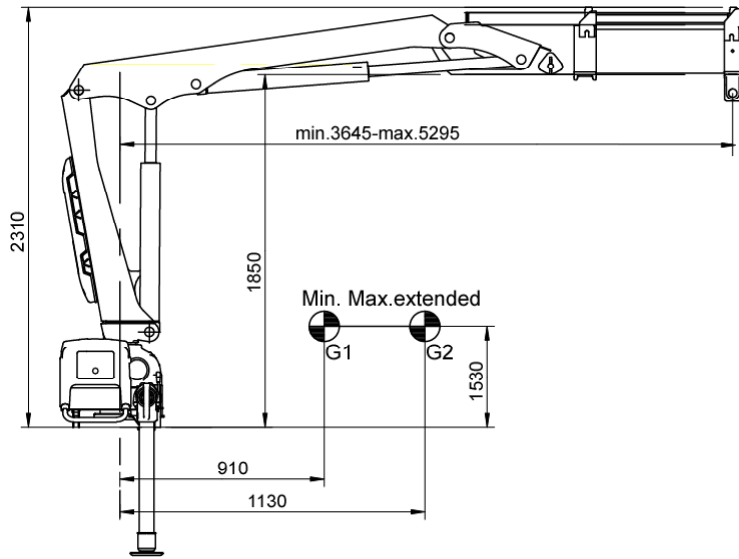

Side View Folded

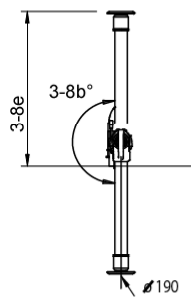
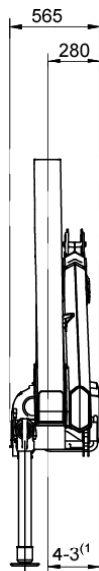

Front View Folded

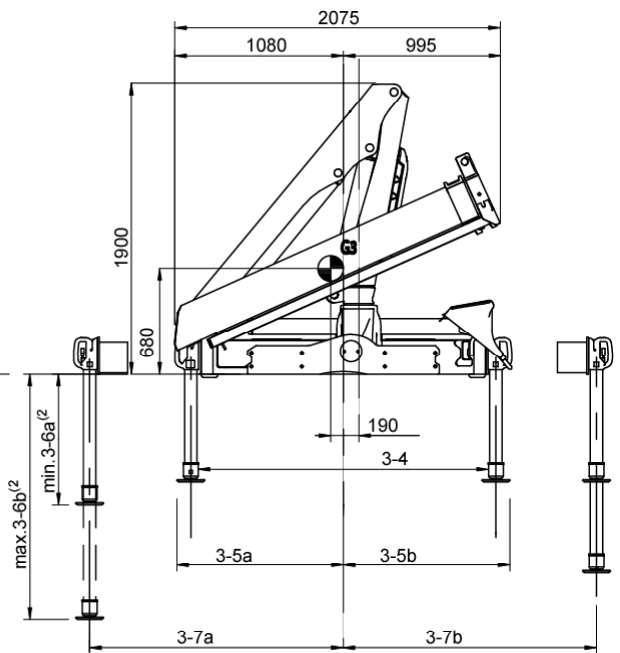

NOTE For specific values, see Table of Measurements

Top View Crane Base

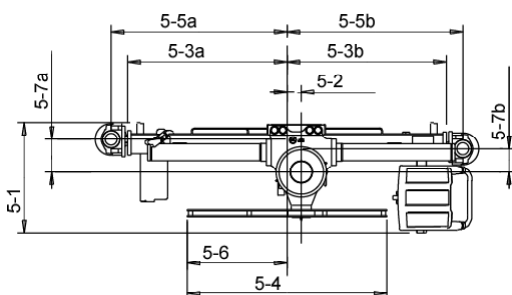

NOTE For specific values, see Table of Measurements

Chassis Installation

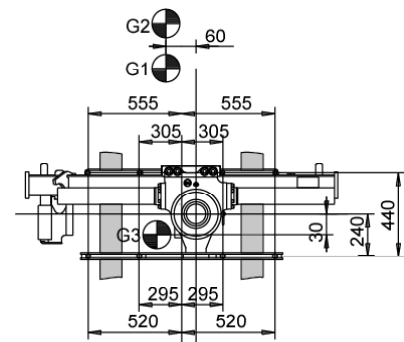

(1) Variable value depending on option.
 (2) Variations may occur depending on mounting position.

Load Diagram

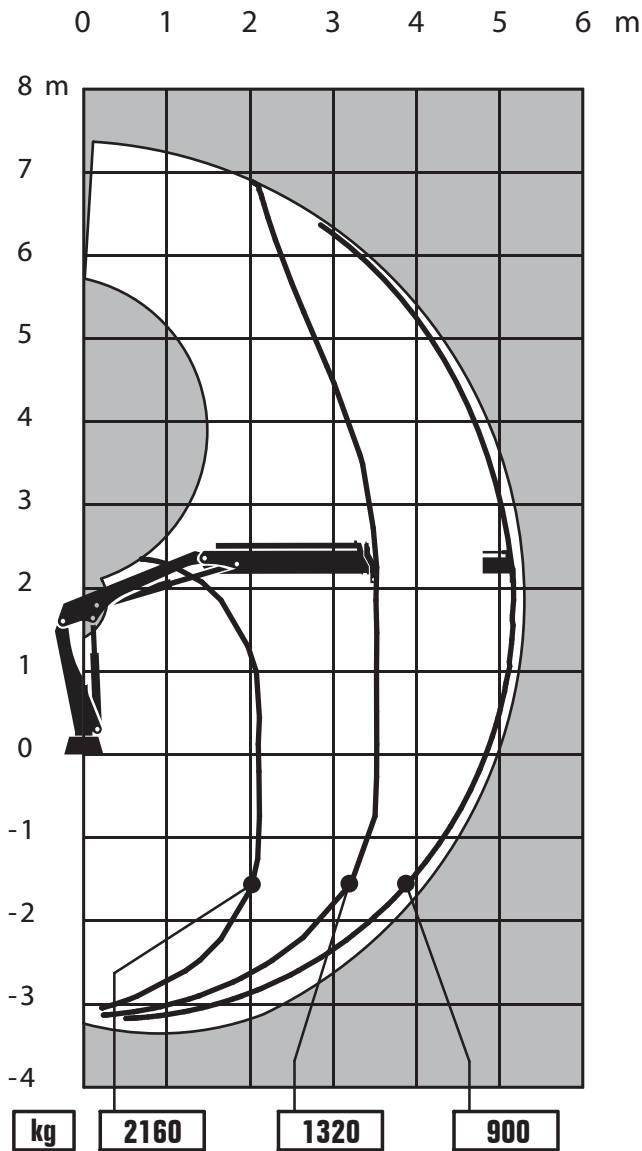

Side View Unfolded Close in Area

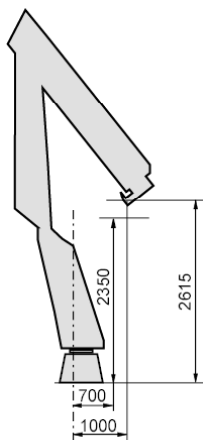

Capacity and performance

Lifting capacity	45 (kNm)
Standard lifting capacity at standard outreach	2.1 (m) - 2160 (kg)
	3.5 (m) - 1320 (kg)
	5.1 (m) - 900 (kg)
Manual lifting capacity at extension	6.9 (m) - 620 (kg)
	8.9 (m) - 440 (kg)

Hydraulic boom extension	1.7 (m)
Lifting height above installation level hydraulic	7.4 (m)
Slewing torque	7.7 (kNm)
V80 Slewing speed	15 (°/s)
Slewing angle	410 (°)
Lifting speed	1.0 (m/s)

Functional demands

Recommended oilflow low	25 (l/min)
Recommended oilflow high	30 (l/min)
Working pressure	22 (MPa)
Max slope viable at full capacity	5 (°)
Oil in tank	35 (l)
Tank capacity	40 (l)

Weights and measurements

Height in folded position	1900 (mm)
Width in folded position	2075 (mm)
Installation space needed	565 (mm)
Weight of crane	730 (kg)
Weight control stations (platform & top seat)	30 (kg)
Weight hose- and pipe kit	30 (kg)

Side View Unfolded Stretched

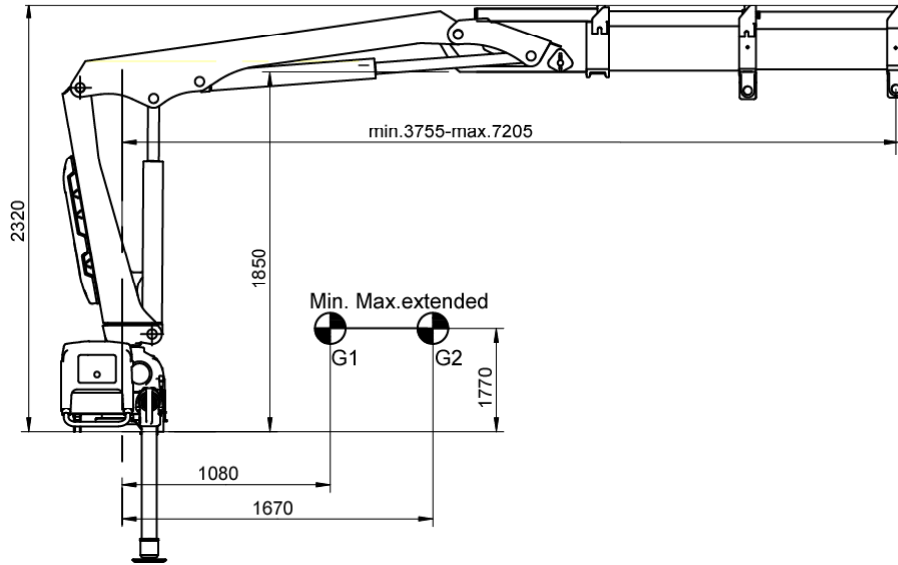

Side View Folded

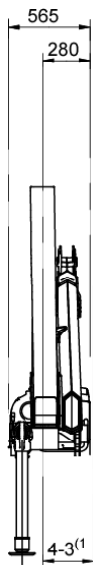

Front View Folded

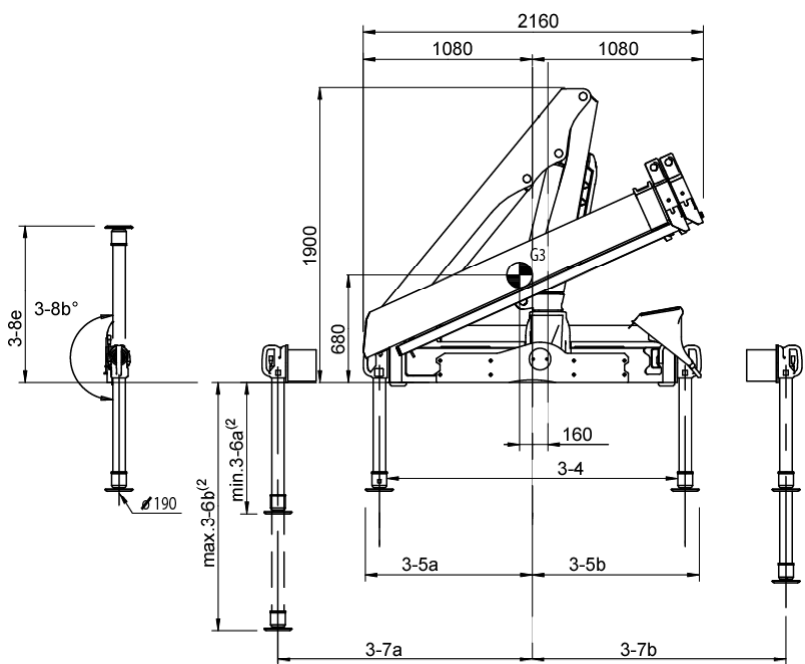

NOTE For specific values, see Table of Measurements

Top View Crane Base

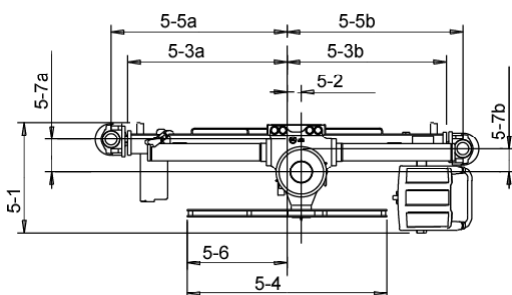

NOTE For specific values, see Table of Measurements

Chassis Installation

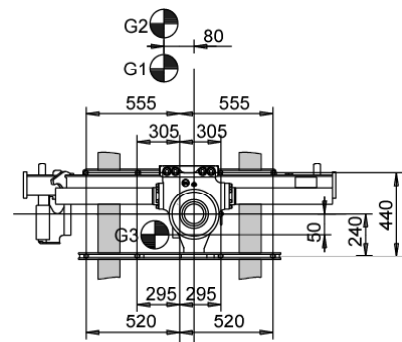

(1) Variable value depending on option.
 (2) Variations may occur depending on mounting position.

Load Diagram

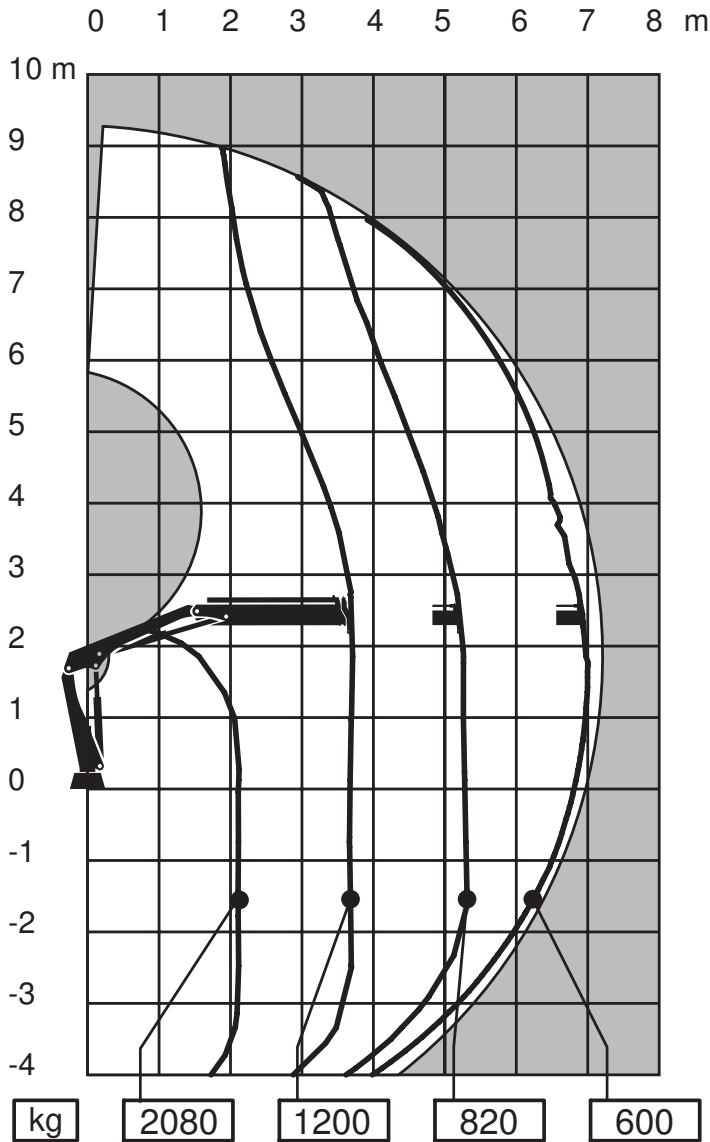

Side View Unfolded Close in Area

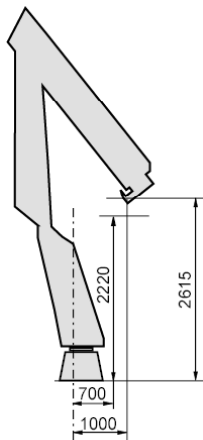

Capacity and performance

Lifting capacity	42 (kNm)
Standard lifting capacity at standard outreach	2.1 (m) - 2080 (kg)
	3.6 (m) - 1200 (kg)
	5.1 (m) - 820 (kg)
	6.9 (m) - 600 (kg)
Manual lifting capacity at extension	8.9 (m) - 420 (kg)
Hydraulic boom extension	3.5 (m)
Lifting height above installation level hydraulic	9.3 (m)
Slewing torque	7.7 (kNm)
V80 Slewing speed	15 (°/s)
Slewing angle	410 (°)
Lifting speed	1.3 (m/s)

Functional demands

Recommended oilflow low	25 (l/min)
Recommended oilflow high	30 (l/min)
Working pressure	22 (MPa)
Max slope viable at full capacity	5 (°)
Oil in tank	35 (l)
Tank capacity	40 (l)

Weights and measurements

Height in folded position	1900 (mm)
Width in folded position	2160 (mm)
Installation space needed	565 (mm)
Weight of crane	810 (kg)
Weight control stations (platform & top seat)	30 (kg)
Weight hose- and pipe kit	35 (kg)

Side View Unfolded Stretched

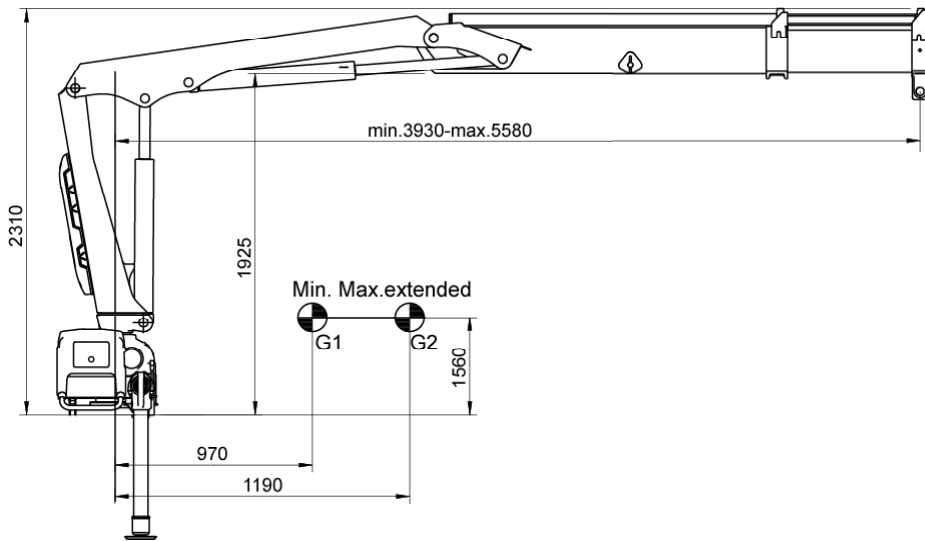

Side View Folded

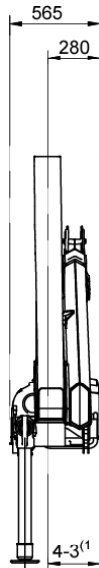

Front View Folded

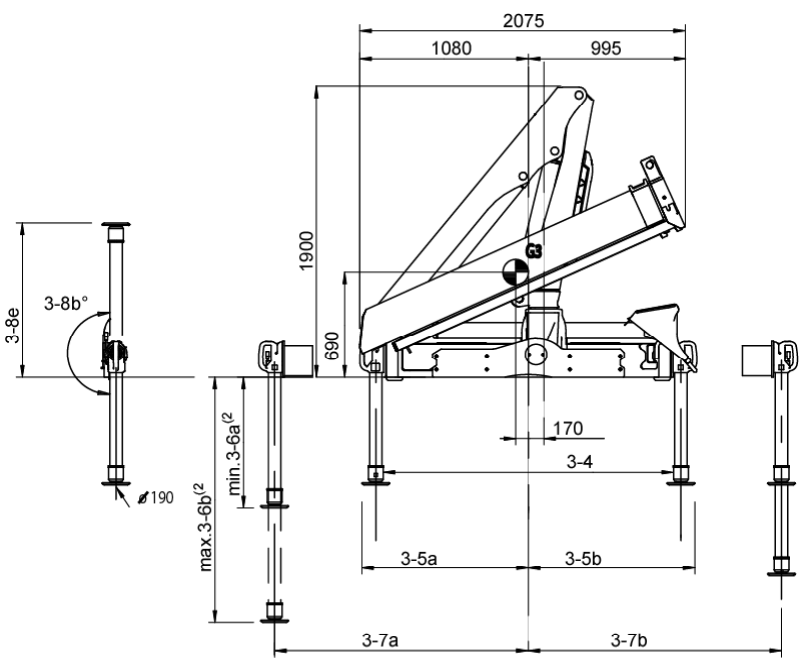

NOTE For specific values, see Table of Measurements

Top View Crane Base

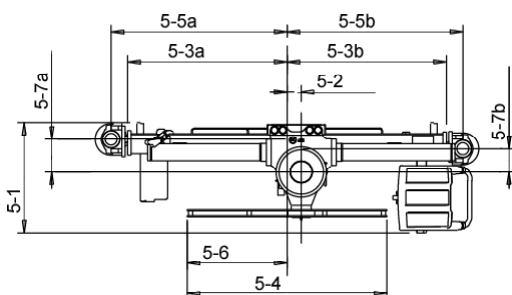

NOTE For specific values, see Table of Measurements

Chassis Installation

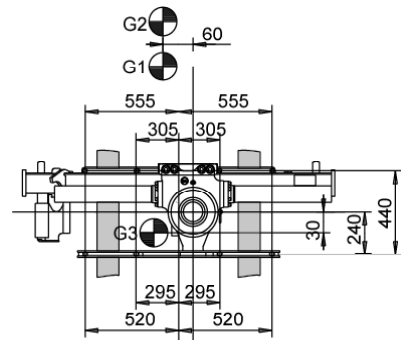

(1) Variable value depending on option.
 (2) Variations may occur depending on mounting position.

Load Diagram

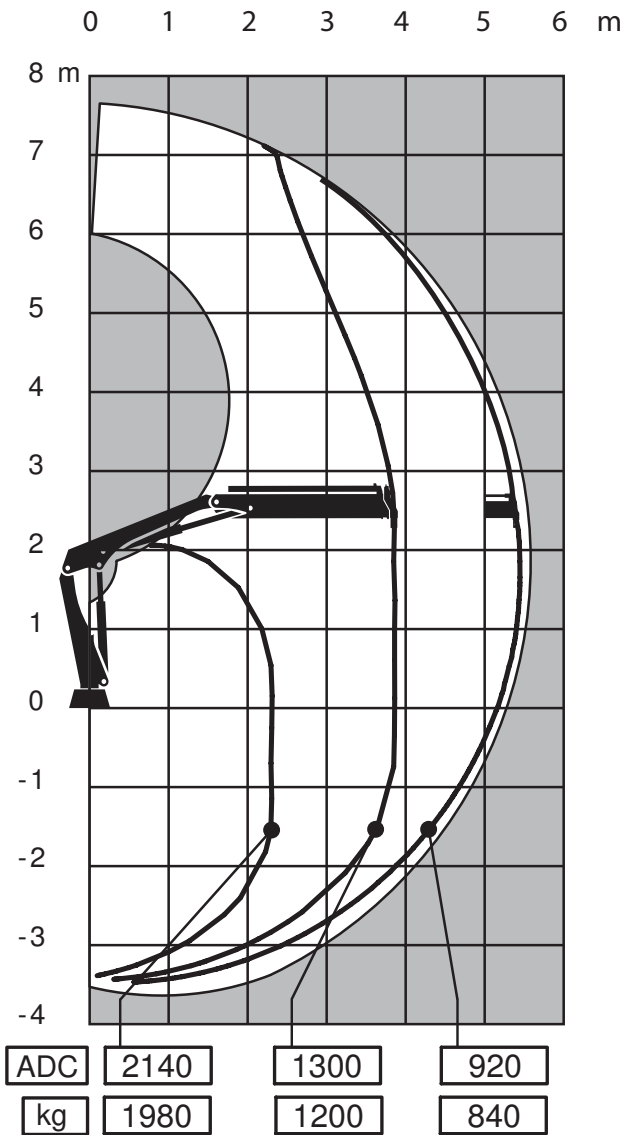

Capacity and performance

Lifting capacity with ADC	48	(kNm)
Lifting capacity	45	(kNm)
Standard lifting capacity at standard outreach with ADC	2.3 (m) - 2140 (kg)	
	3.8 (m) - 1300 (kg)	
	5.4 (m) - 920 (kg)	
Standard lifting capacity at standard outreach	2.3 (m) - 1980 (kg)	
	3.8 (m) - 1200 (kg)	
	5.4 (m) - 840 (kg)	
Manual lifting capacity at extension	7.2 (m) - 640 (kg)	
	9.1 (m) - 460 (kg)	
Hydraulic boom extension	1.7	(m)
Lifting height above installation level hydraulic	7.7	(m)
Slewing torque	7.7	(kNm)
V80 Slewing speed	15	(°/s)
Slewing angle	410	(°)
Lifting speed	1.0	(m/s)

Functional demands

Recommended oilflow low	25	(l/min)
Recommended oilflow high	30	(l/min)
Working pressure	24	(MPa)
Max slope viable at full capacity	5	(°)
Oil in tank	35	(l)
Tank capacity	40	(l)

Weights and measurements

Height in folded position	1900	(mm)
Width in folded position	2075	(mm)
Installation space needed	565	(mm)
Weight of crane	730	(kg)
Weight control stations (platform & top seat)	30	(kg)
Weight hose- and pipe kit	30	(kg)

Side View Unfolded Close in Area

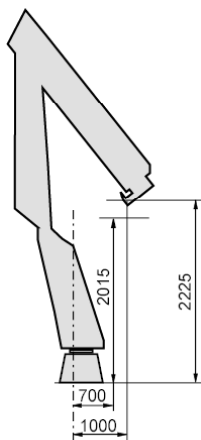

Side View Unfolded Stretched

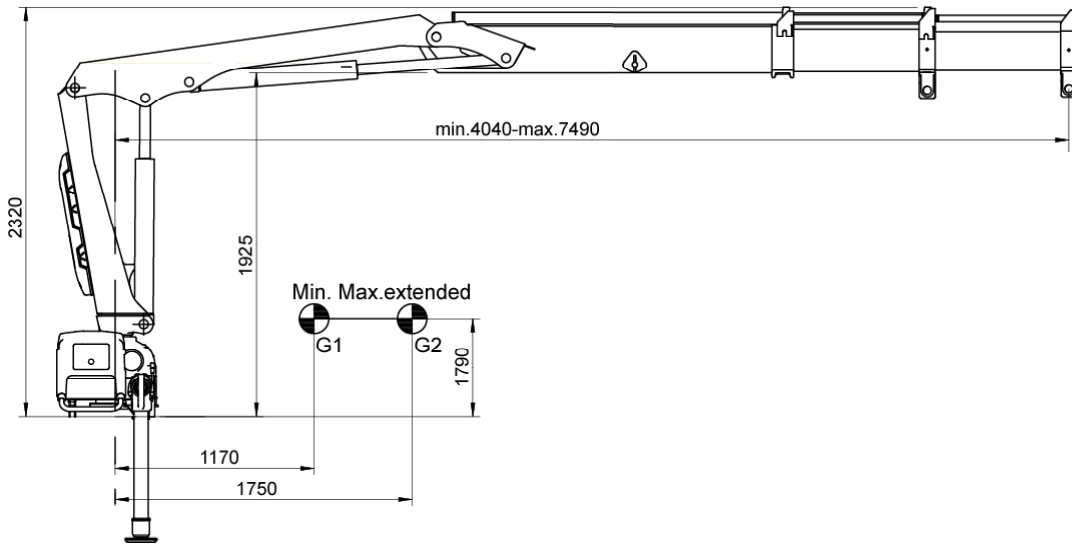

Side View Folded

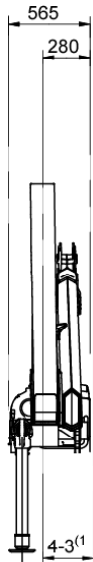

Front View Folded

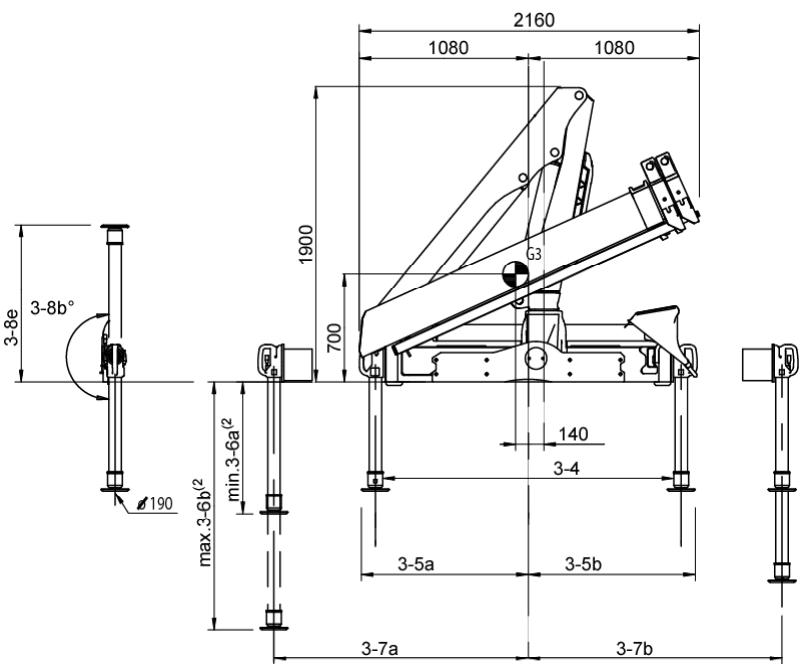

NOTE For specific values, see Table of Measurements

Top View Crane Base

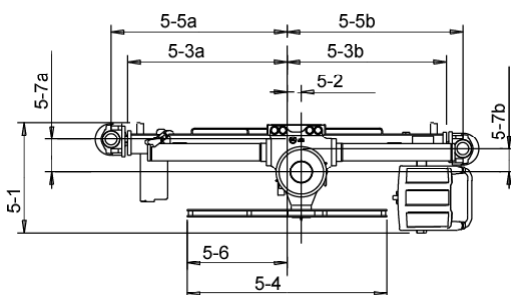

NOTE For specific values, see Table of Measurements

Chassis Installation

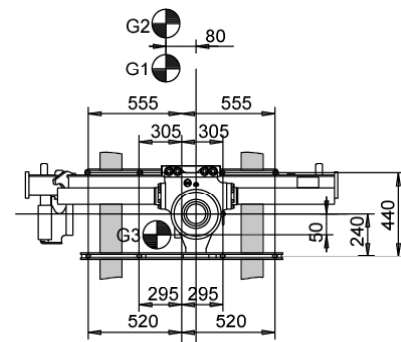

(1) Variable value depending on option.
 (2) Variations may occur depending on mounting position.

Load Diagram

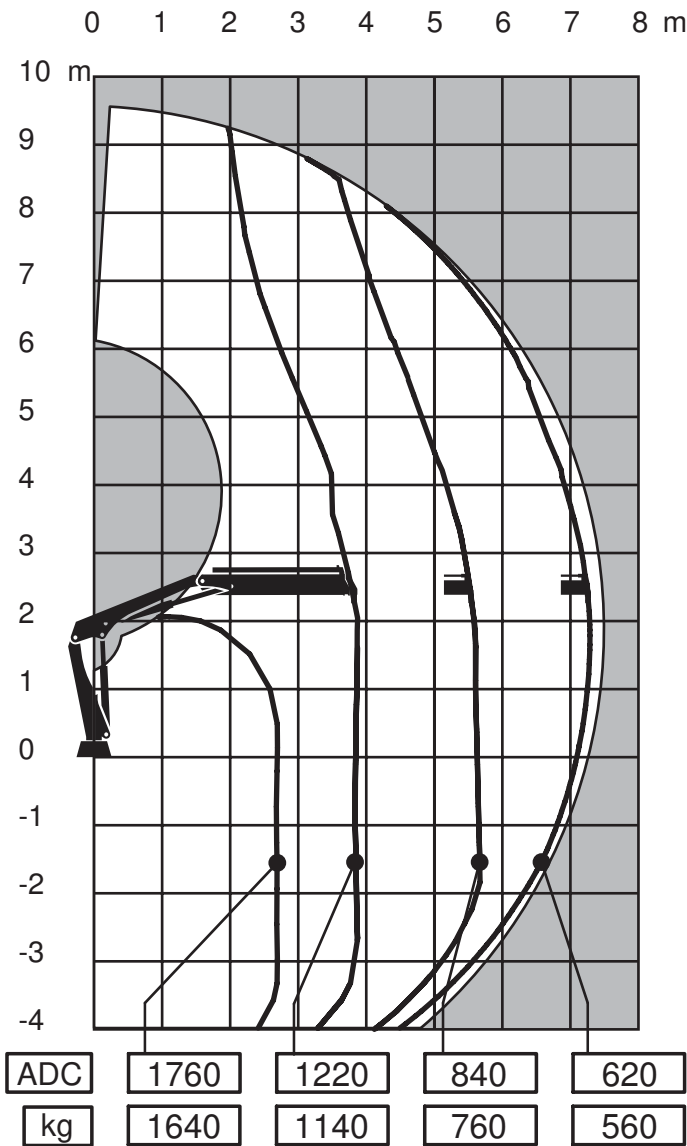

Side View Unfolded Close in Area

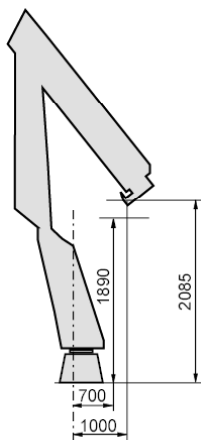

Capacity and performance

Lifting capacity with ADC	45	(kNm)
Lifting capacity	42	(kNm)
Standard lifting capacity at standard outreach with ADC	2.7 (m) - 1760 (kg)	
	3.8 (m) - 1220 (kg)	
	5.4 (m) - 840 (kg)	
	7.2 (m) - 620 (kg)	
Standard lifting capacity at standard outreach	2.7 (m) - 1640 (kg)	
	3.8 (m) - 1140 (kg)	
	5.4 (m) - 760 (kg)	
	7.2 (m) - 560 (kg)	
Manual lifting capacity at extension	9.1 (m) - 440 (kg)	
Hydraulic boom extension	3.5	(m)
Lifting height above installation level hydraulic	9.6	(m)
Slewing torque	7.7	(kNm)
V80 Slewing speed	15	(°/s)
Slewing angle	410	(°)
Lifting speed	1.4	(m/s)

Functional demands

Recommended oilflow low	25	(l/min)
Recommended oilflow high	30	(l/min)
Working pressure	24	(MPa)
Max slope viable at full capacity	5	(°)
Oil in tank	35	(l)
Tank capacity	40	(l)

Weights and measurements

Height in folded position	1900	(mm)
Width in folded position	2160	(mm)
Installation space needed	565	(mm)
Weight of crane	810	(kg)
Weight control stations (platform & top seat)	30	(kg)
Weight hose- and pipe kit	35	(kg)

Side View Unfolded Stretched

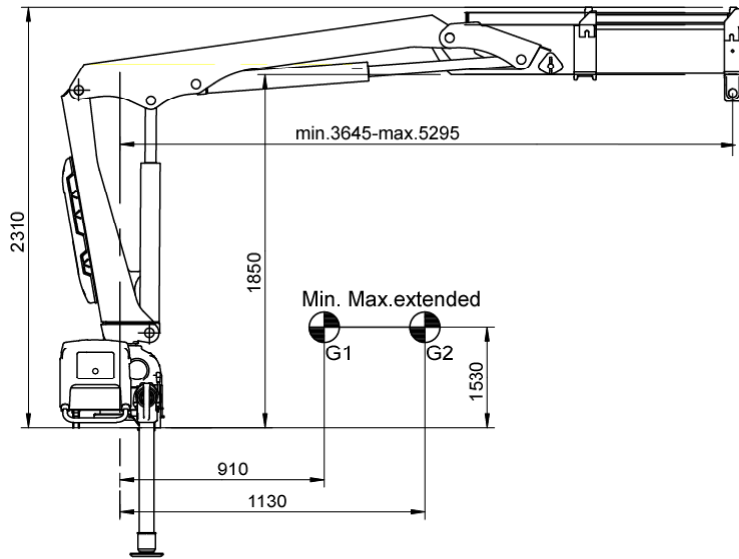

Side View Folded

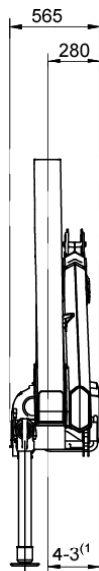

Front View Folded

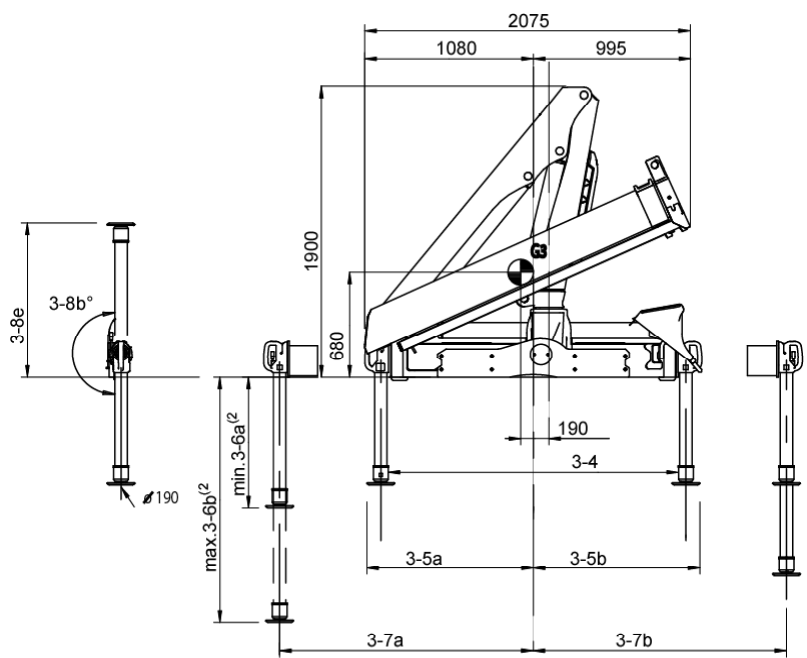

NOTE For specific values, see Table of Measurements

Top View Crane Base

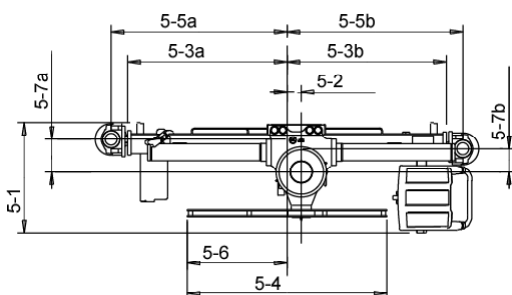

NOTE For specific values, see Table of Measurements

Chassis Installation

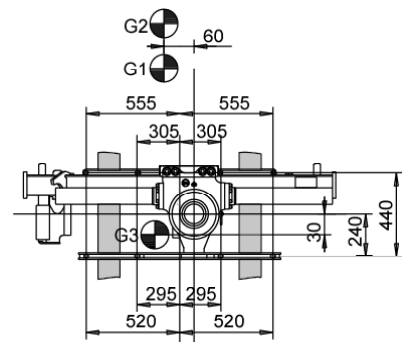

(1) Variable value depending on option.
 (2) Variations may occur depending on mounting position.

Load Diagram

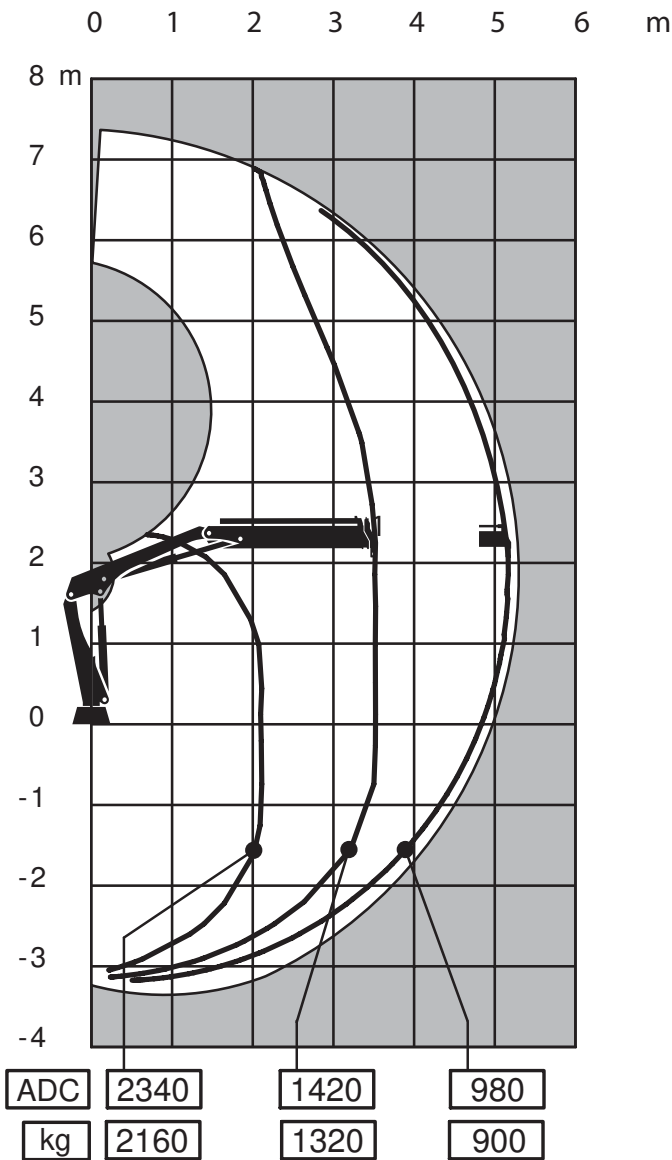

Side View Unfolded Close in Area

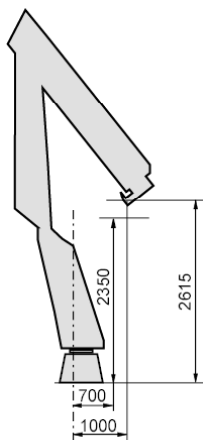

Capacity and performance

Lifting capacity with ADC	49 (kNm)
Lifting capacity	45 (kNm)
Standard lifting capacity at standard outreach with ADC	2.1 (m) - 2340 (kg)
	3.5 (m) - 1420 (kg)
	5.1 (m) - 980 (kg)
Standard lifting capacity at standard outreach	2.1 (m) - 2160 (kg)
	3.5 (m) - 1320 (kg)
	5.1 (m) - 900 (kg)
Manual lifting capacity at extension	6.9 (m) - 680 (kg)
	8.9 (m) - 480 (kg)
Hydraulic boom extension	1.7 (m)
Lifting height above installation level hydraulic	7.4 (m)
Sewing torque	7.7 (kNm)
V80 Sewing speed	15 (°/s)
Sewing angle	410 (°)
Lifting speed	1.0 (m/s)

Functional demands

Recommended oil low	25 (l/min)
Recommended oil high	30 (l/min)
Working pressure	24 (MPa)
Max slope viable at full capacity	5 (°)
Oil in tank	35 (l)
Tank capacity	40 (l)

Weights and measurements

Height in folded position	1900 (mm)
Width in folded position	2075 (mm)
Installation space needed	565 (mm)
Weight of crane	730 (kg)
Weight control stations (platform & top seat)	30 (kg)
Weight hose- and pipe kit	30 (kg)

Side View Unfolded Stretched

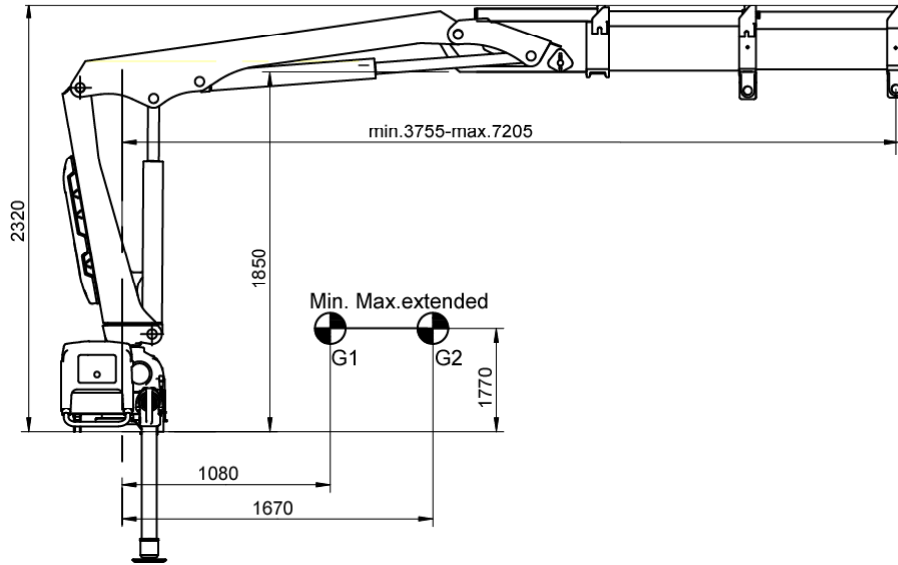

Side View Folded

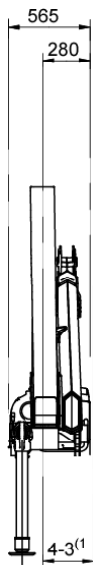

Front View Folded

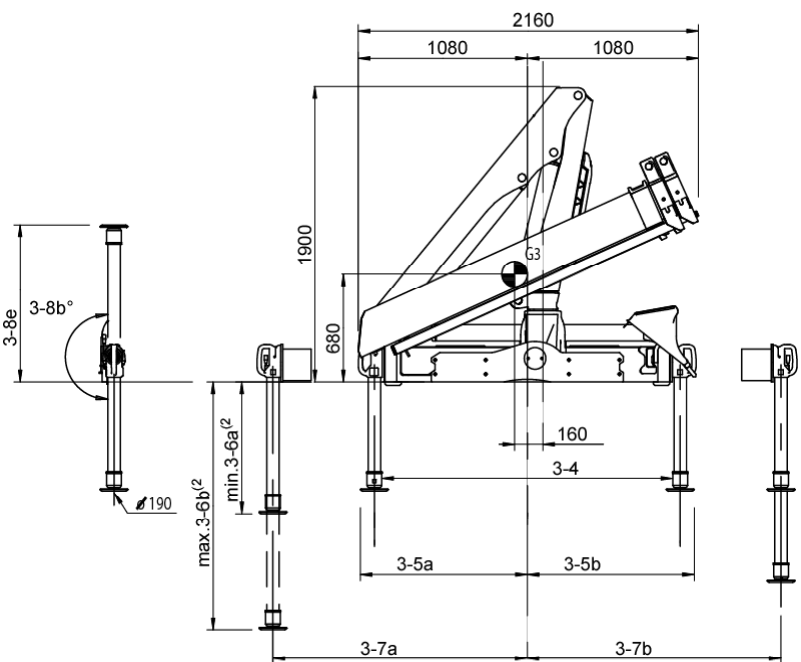

NOTE For specific values, see Table of Measurements

Top View Crane Base

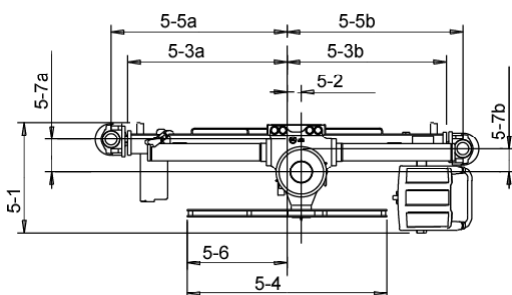

NOTE For specific values, see Table of Measurements

Chassis Installation

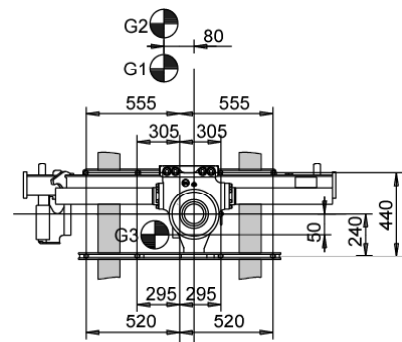

(1) Variable value depending on option.
 (2) Variations may occur depending on mounting position.

Load Diagram

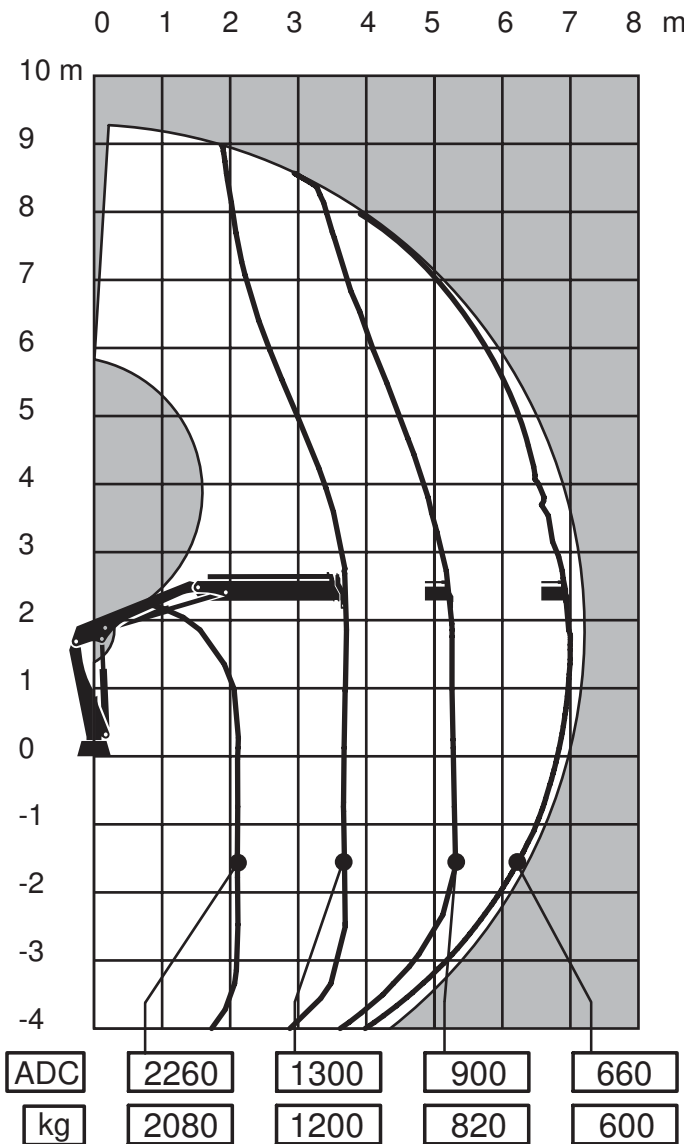

Side View Unfolded Close in Area

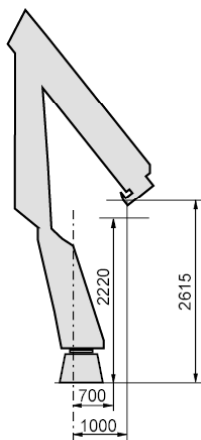

Capacity and performance

Lifting capacity with ADC	46	(kNm)
Lifting capacity	42	(kNm)
Standard lifting capacity at standard outreach with ADC	2.1 (m) - 2260 (kg)	
	3.6 (m) - 1300 (kg)	
	5.1 (m) - 900 (kg)	
	6.9 (m) - 660 (kg)	
Standard lifting capacity at standard outreach	2.1 (m) - 2080 (kg)	
	3.6 (m) - 1200 (kg)	
	5.1 (m) - 820 (kg)	
	6.9 (m) - 600 (kg)	
Manual lifting capacity at extension	8.9 (m) - 460 (kg)	
Hydraulic boom extension	3.5	(m)
Lifting height above installation level hydraulic	9.3	(m)
Slewing torque	7.7	(kNm)
V80 Slewing speed	15	(°/s)
Slewing angle	410	(°)
Lifting speed	1.3	(m/s)

Functional demands

Recommended oilflow low	25	(l/min)
Recommended oilflow high	30	(l/min)
Working pressure	24	(MPa)
Max slope viable at full capacity	5	(°)
Oil in tank	35	(l)
Tank capacity	40	(l)

Weights and measurements

Height in folded position	1900	(mm)
Width in folded position	2160	(mm)
Installation space needed	565	(mm)
Weight of crane	810	(kg)
Weight control stations (platform & top seat)	30	(kg)
Weight hose- and pipe kit	35	(kg)

Side View Unfolded Stretched

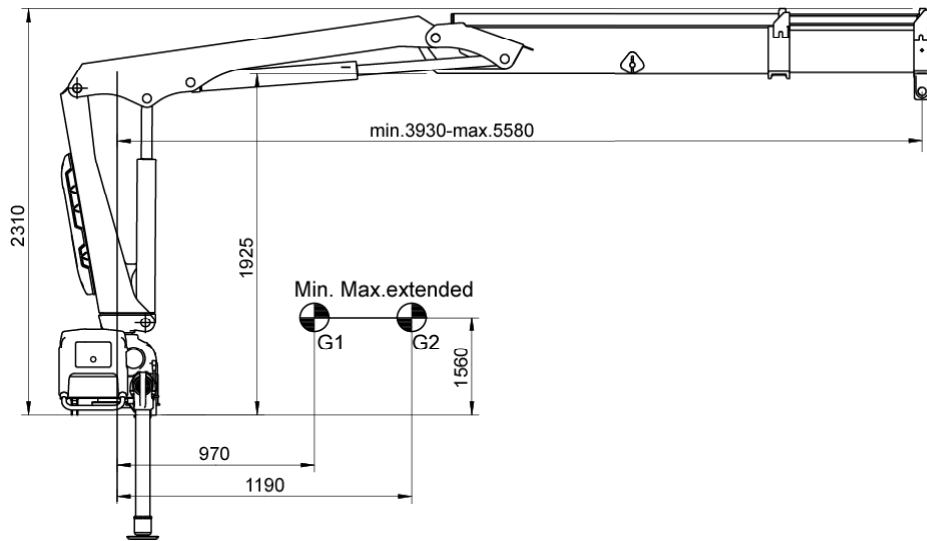

Side View Folded

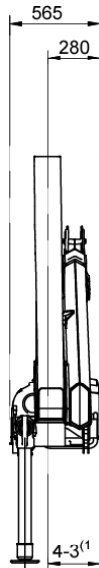

Front View Folded

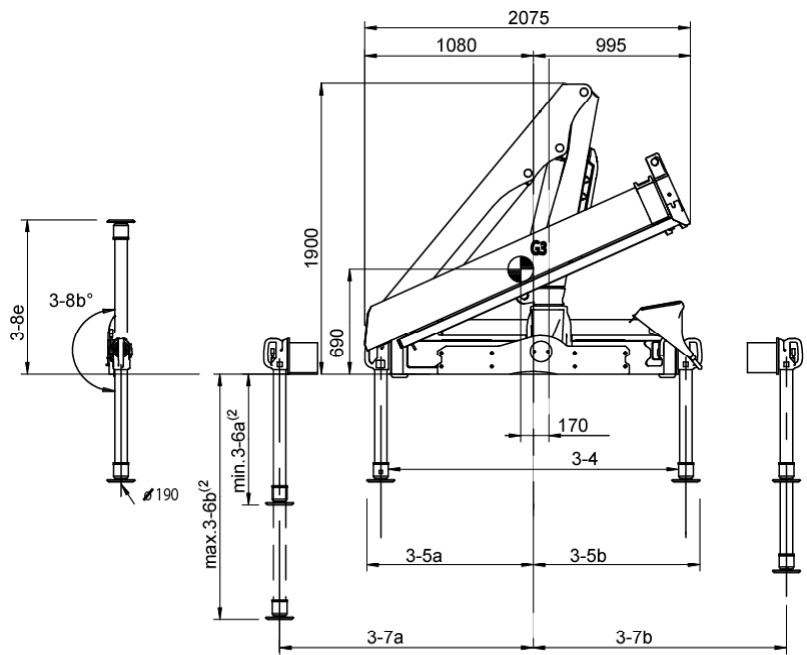

NOTE For specific values, see Table of Measurements

Top View Crane Base

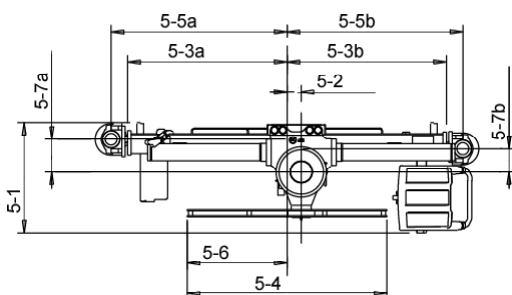

NOTE For specific values, see Table of Measurements

Chassis Installation

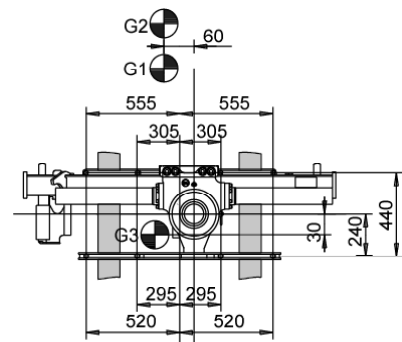

(1) Variable value depending on option.
 (2) Variations may occur depending on mounting position.

Load Diagram

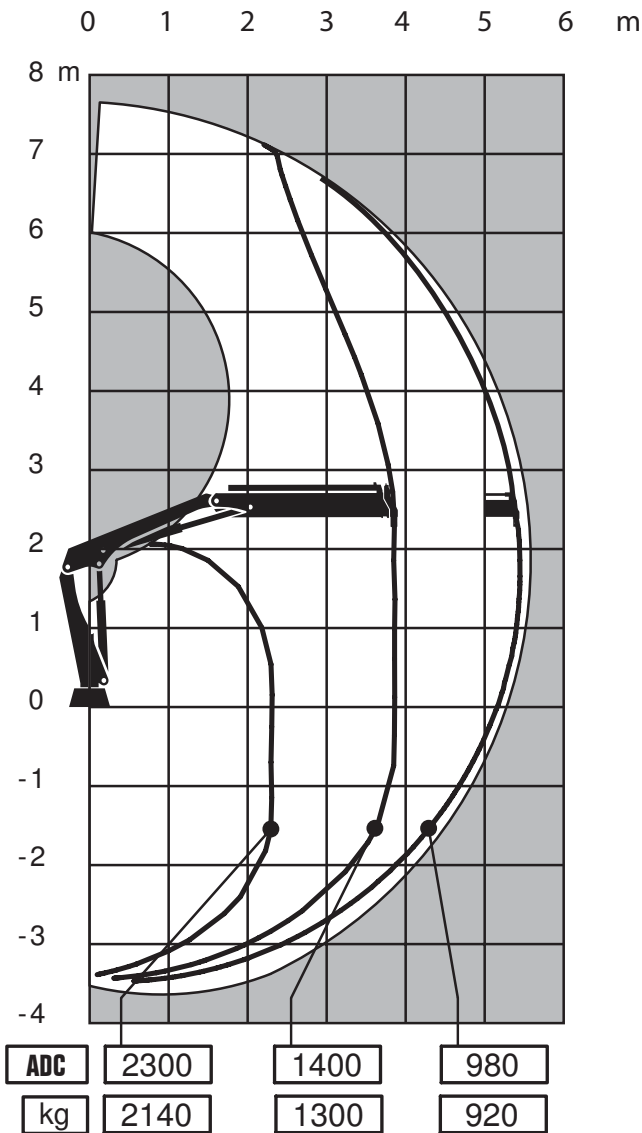

Capacity and performance

Lifting capacity with ADC	52 (kNm)
Lifting capacity	48 (kNm)
Standard lifting capacity at standard outreach with ADC	2.3 (m) - 2300 (kg)
	3.8 (m) - 1400 (kg)
	5.4 (m) - 980 (kg)
Standard lifting capacity at standard outreach	2.3 (m) - 2140 (kg)
	3.8 (m) - 1300 (kg)
	5.4 (m) - 920 (kg)
Manual lifting capacity at extension	7.2 (m) - 680 (kg)
	9.1 (m) - 500 (kg)
Hydraulic boom extension	1.7 (m)
Lifting height above installation level hydraulic	7.7 (m)
Slewing torque	7.7 (kNm)
V80 Slewing speed	15 (°/s)
Slewing angle	410 (°)
Lifting speed	1.0 (m/s)

Functional demands

Recommended oilflow low	30 (l/min)
Recommended oilflow high	40 (l/min)
Working pressure	26 (MPa)
Max slope viable at full capacity	5 (°)
Oil in tank	65 (l)
Tank capacity	75 (l)

Weights and measurements

Height in folded position	1900 (mm)
Width in folded position	2075 (mm)
Installation space needed	565 (mm)
Weight of crane	730 (kg)
Weight control stations (platform & top seat)	30 (kg)
Weight hose- and pipe kit	30 (kg)

Side View Unfolded Close in Area

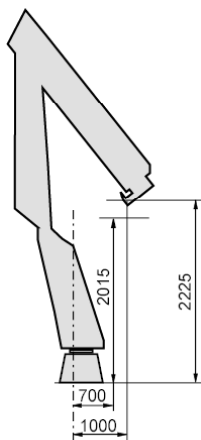

Side View Unfolded Stretched

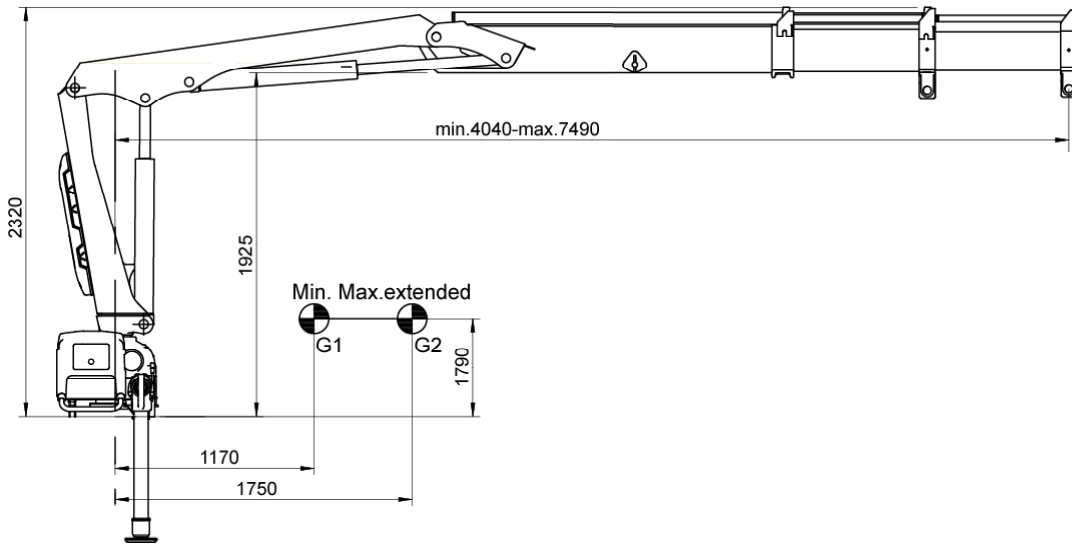

Side View Folded

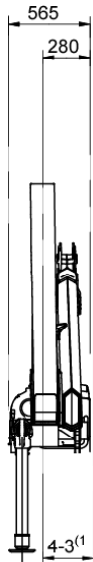

Front View Folded

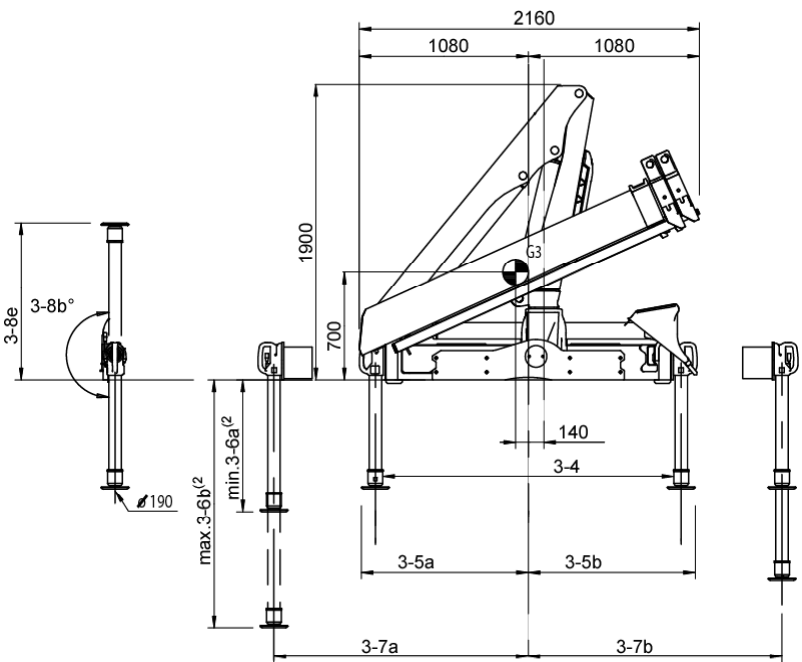

NOTE For specific values, see Table of Measurements

Top View Crane Base

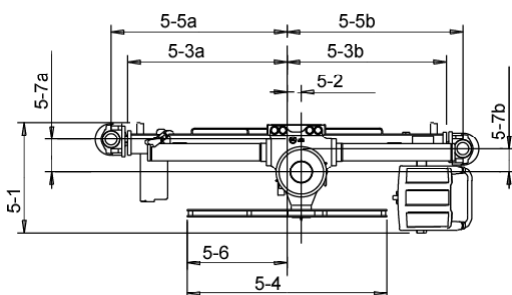

NOTE For specific values, see Table of Measurements

Chassis Installation

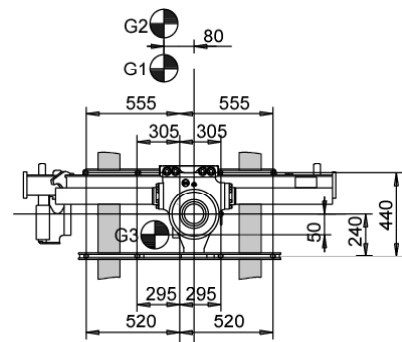

(1) Variable value depending on option.
 (2) Variations may occur depending on mounting position.

Load Diagram

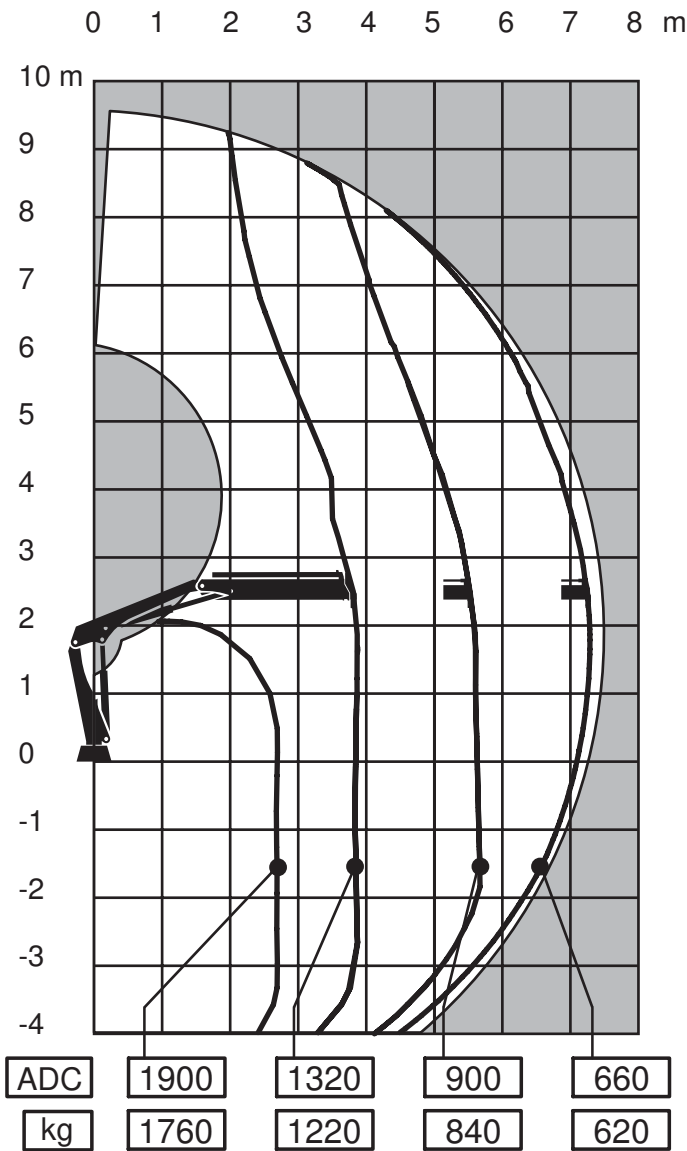

Side View Unfolded Close in Area

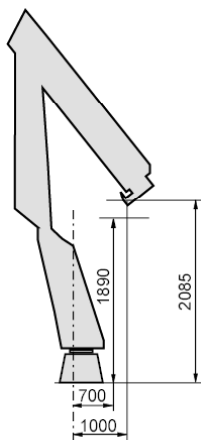

Capacity and performance

Lifting capacity with ADC	49	(kNm)
Lifting capacity	45	(kNm)
Standard lifting capacity at standard outreach with ADC	2.7	(m) - 1900 (kg)
	3.8	(m) - 1320 (kg)
	5.4	(m) - 900 (kg)
	7.2	(m) - 660 (kg)
Standard lifting capacity at standard outreach	2.7	(m) - 1760 (kg)
	3.8	(m) - 1220 (kg)
	5.4	(m) - 840 (kg)
	7.2	(m) - 620 (kg)
Manual lifting capacity at extension	9.1	(m) - 490 (kg)
Hydraulic boom extension	3.5	(m)
Lifting height above installation level hydraulic	9.6	(m)
Slewing torque	7.7	(kNm)
V80 Slewing speed	15	(°/s)
Slewing angle	410	(°)
Lifting speed	1.4	(m/s)

Functional demands

Recommended oilflow low	30	(l/min)
Recommended oilflow high	40	(l/min)
Working pressure	26	(MPa)
Max slope viable at full capacity	5	(°)

Oil in tank	65	(l)
Tank capacity	75	(l)

Weights and measurements

Height in folded position	1900	(mm)
Width in folded position	2160	(mm)
Installation space needed	565	(mm)
Weight of crane	810	(kg)
Weight control stations (platform & top seat)	30	(kg)
Weight hose- and pipe kit	35	(kg)

Side View Unfolded Stretched

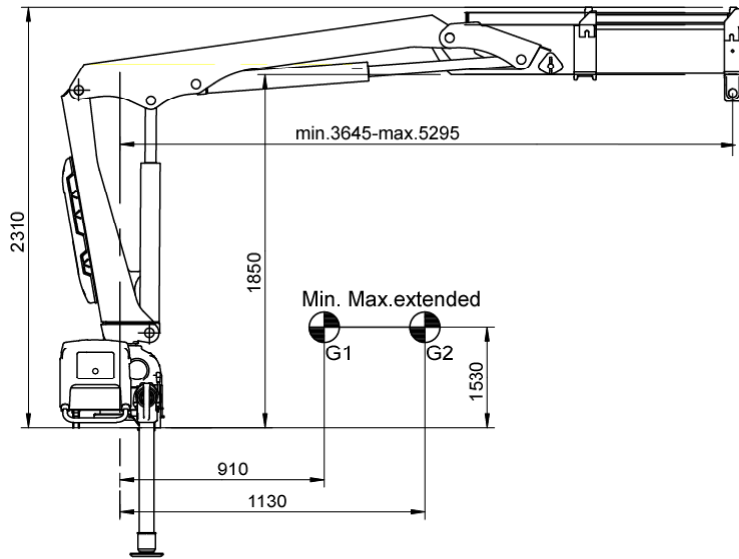

Side View Folded

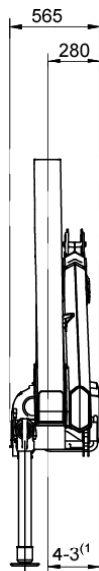

Front View Folded

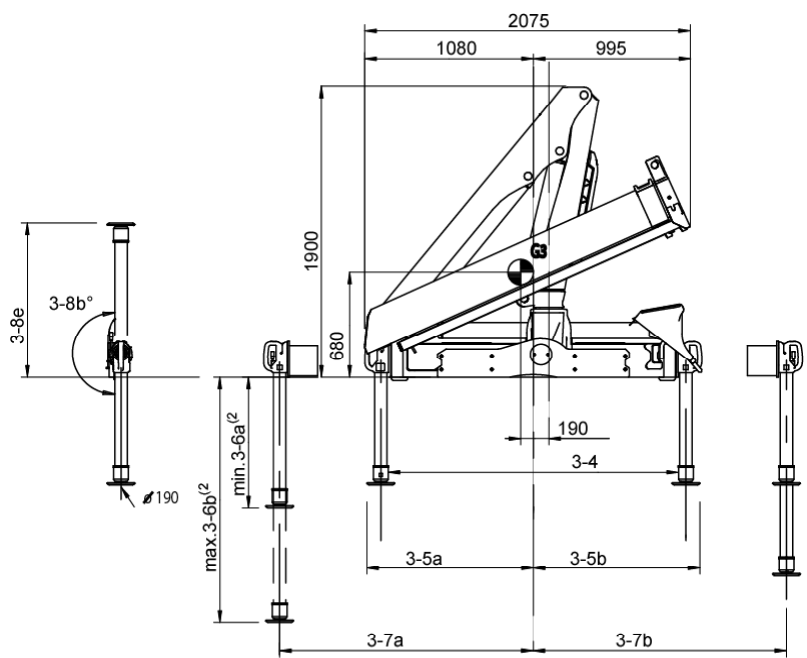

NOTE For specific values, see Table of Measurements

Top View Crane Base

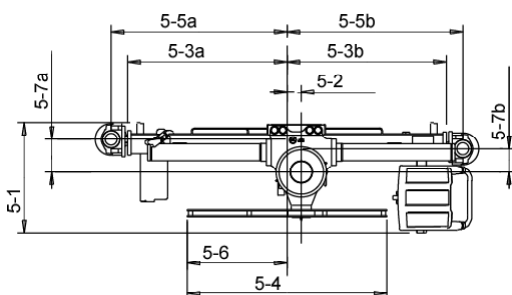

NOTE For specific values, see Table of Measurements

Chassis Installation

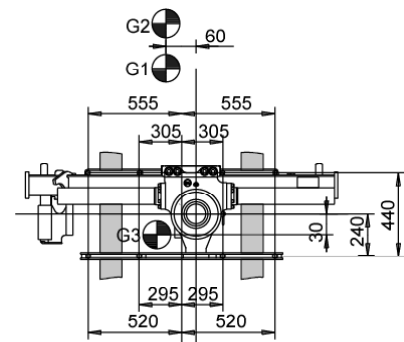

(1) Variable value depending on option.
 (2) Variations may occur depending on mounting position.

Load Diagram

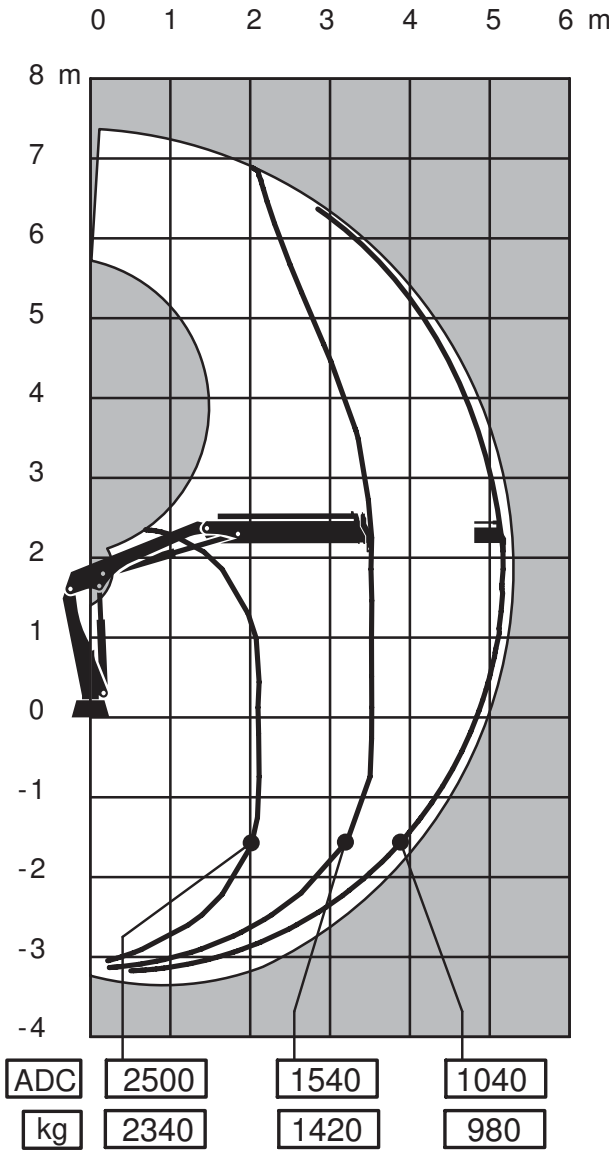

Side View Unfolded Close in Area

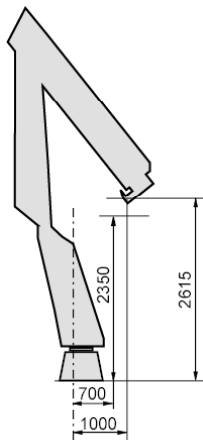

Capacity and performance

Lifting capacity with ADC	53	(kNm)
Lifting capacity	49	(kNm)
Standard lifting capacity at standard outreach with ADC	2.1 (m) - 2500 (kg)	
	3.5 (m) - 1540 (kg)	
	5.1 (m) - 1040 (kg)	
Standard lifting capacity at standard outreach	2.1 (m) - 2340 (kg)	
	3.5 (m) - 1420 (kg)	
	5.1 (m) - 980 (kg)	
Manual lifting capacity at extension	6.9 (m) - 720 (kg)	
	8.9 (m) - 520 (kg)	
Hydraulic boom extension	1.7	(m)
Lifting height above installation level hydraulic	7.4	(m)
Slewing torque	7.7	(kNm)
V80 Slewing speed	15	(°/s)
Slewing angle	410	(°)
Lifting speed	1.0	(m/s)

Functional demands

Recommended oilflow low	30	(l/min)
Recommended oilflow high	40	(l/min)
Working pressure	26	(MPa)
Max slope viable at full capacity	5	(°)

Oil in tank	65	(l)
Tank capacity	75	(l)

Weights and measurements

Height in folded position	1900	(mm)
Width in folded position	2075	(mm)
Installation space needed	565	(mm)
Weight of crane	730	(kg)
Weight control stations (platform & top seat)	30	(kg)
Weight hose- and pipe kit	30	(kg)

Side View Unfolded Stretched

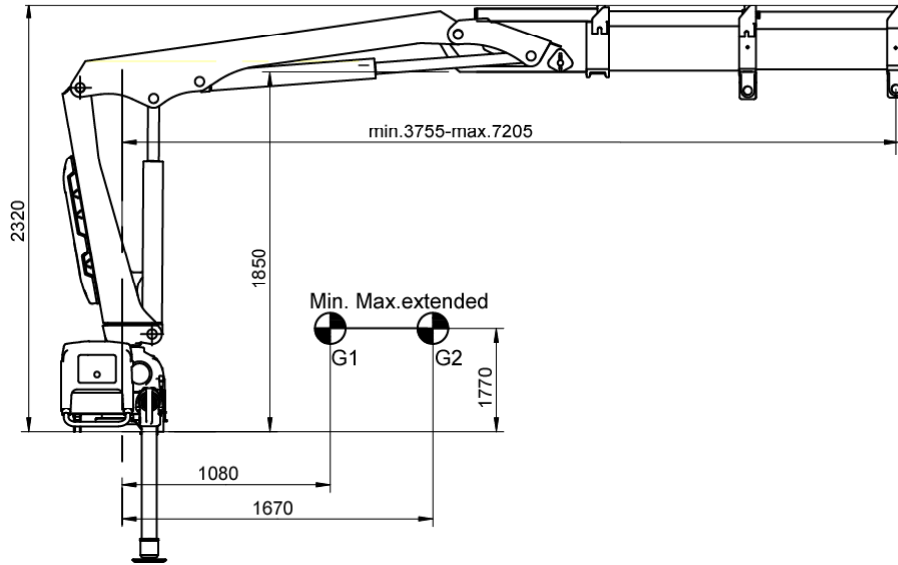

Side View Folded

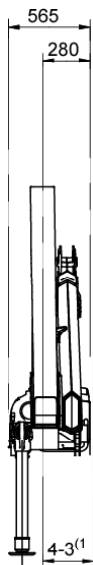

Front View Folded

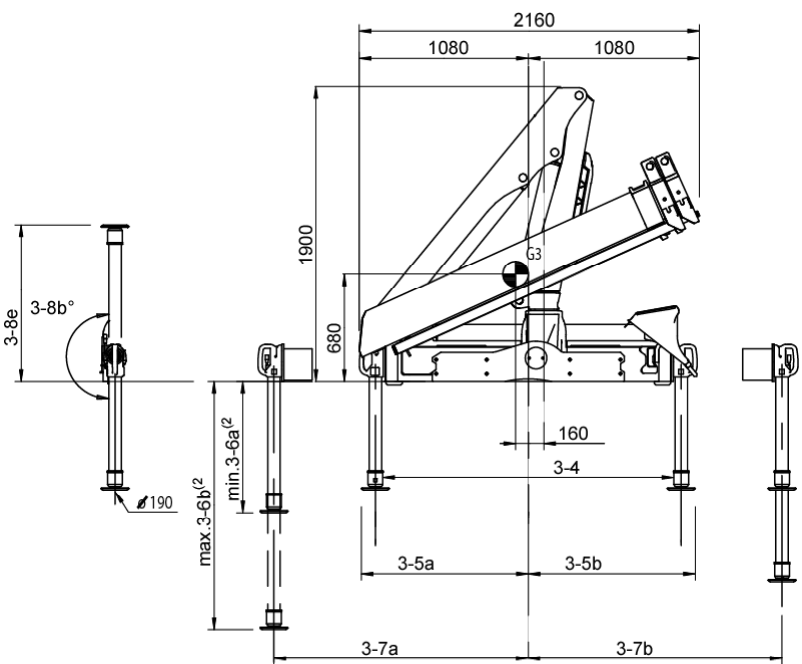

NOTE For specific values, see Table of Measurements

Top View Crane Base

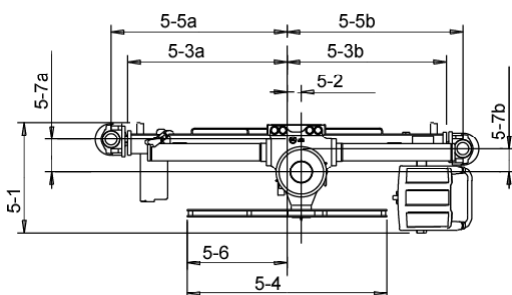

NOTE For specific values, see Table of Measurements

Chassis Installation

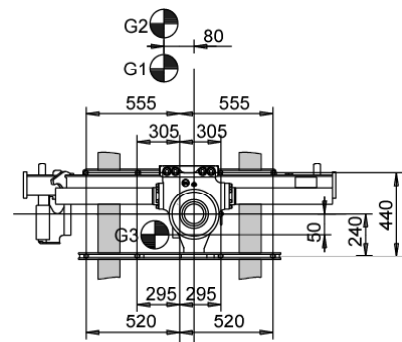

(1) Variable value depending on option.
 (2) Variations may occur depending on mounting position.

Load Diagram

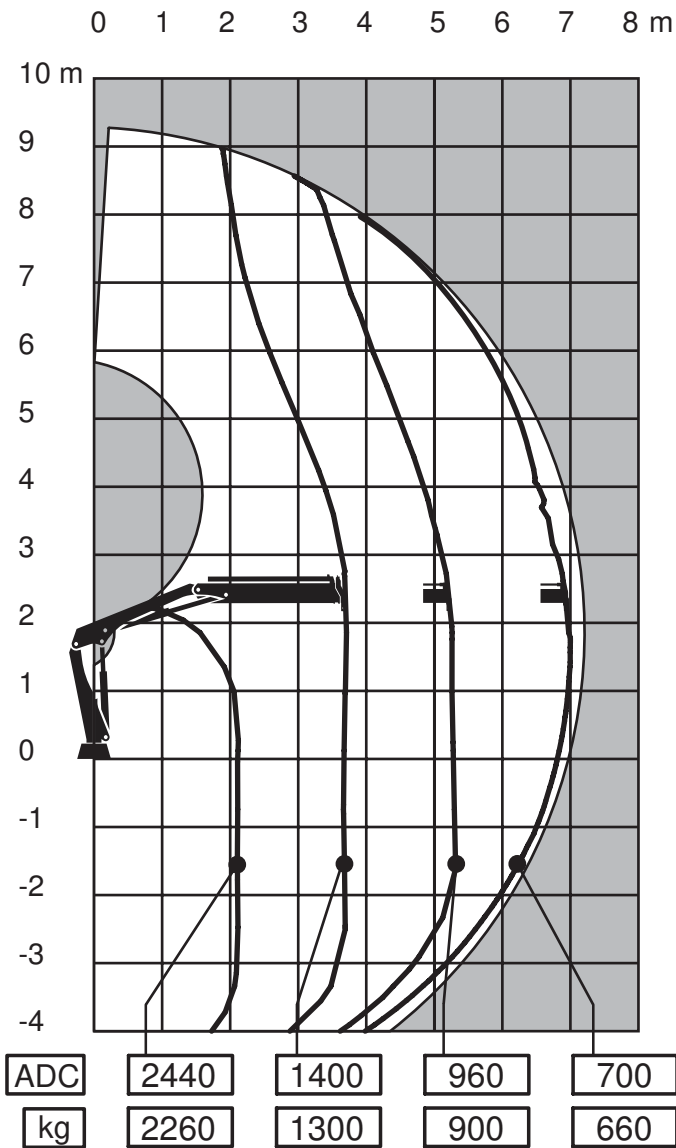

Side View Unfolded Close in Area

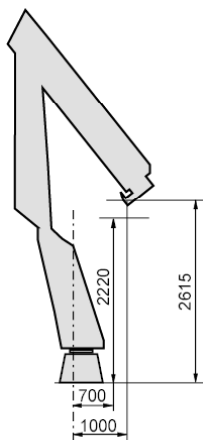

Capacity and performance

Lifting capacity with ADC	49	(kNm)
Lifting capacity	46	(kNm)
Standard lifting capacity at standard outreach with ADC	2.1 (m) - 2440 (kg)	
	3.6 (m) - 1400 (kg)	
	5.1 (m) - 960 (kg)	
	6.9 (m) - 700 (kg)	
Standard lifting capacity at standard outreach	2.1 (m) - 2260 (kg)	
	3.6 (m) - 1300 (kg)	
	5.1 (m) - 900 (kg)	
	6.9 (m) - 660 (kg)	
Manual lifting capacity at extension	8.9 (m) - 500 (kg)	
Hydraulic boom extension	3.5	(m)
Lifting height above installation level hydraulic	9.3	(m)
Slewing torque	7.7	(kNm)
V80 Slewing speed	15	(°/s)
Slewing angle	410	(°)
Lifting speed	1.3	(m/s)

Functional demands

Recommended oilflow low	30	(l/min)
Recommended oilflow high	40	(l/min)
Working pressure	26	(MPa)
Max slope viable at full capacity	5	(°)
Oil in tank	65	(l)
Tank capacity	75	(l)

Weights and measurements

Height in folded position	1900	(mm)
Width in folded position	2160	(mm)
Installation space needed	565	(mm)
Weight of crane	810	(kg)
Weight control stations (platform & top seat)	30	(kg)
Weight hose- and pipe kit	35	(kg)

Side View Unfolded Stretched

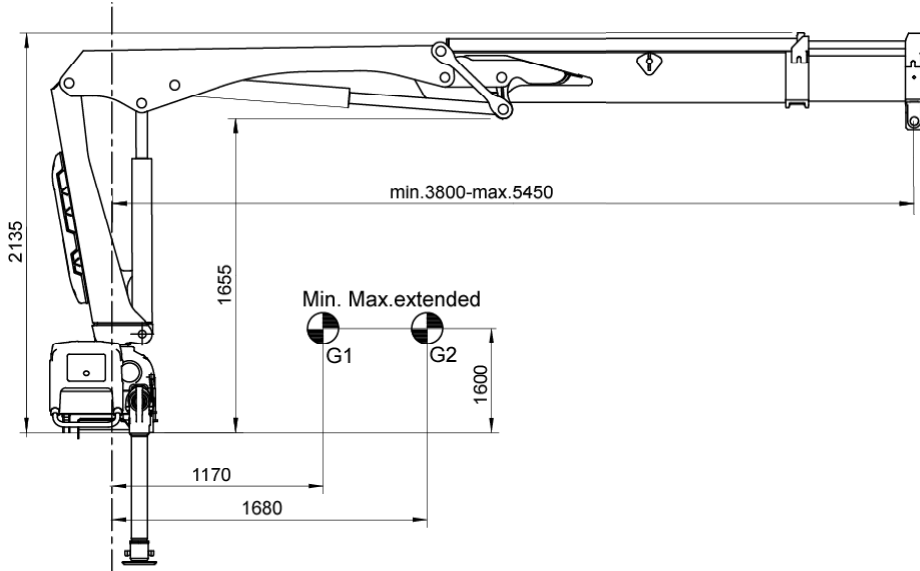

Side View Folded



Front View Folded

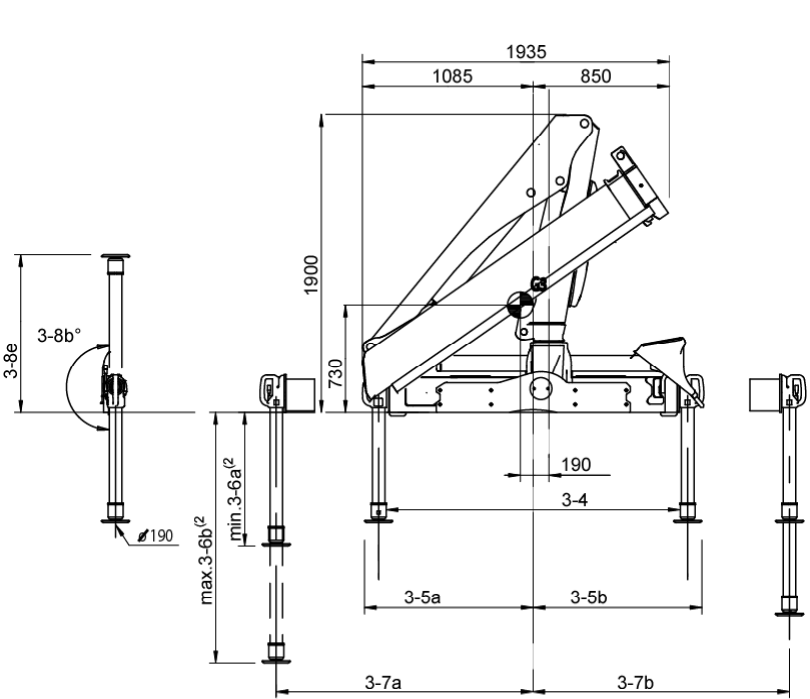

NOTE For specific values, see Table of Measurements

Top View Crane Base

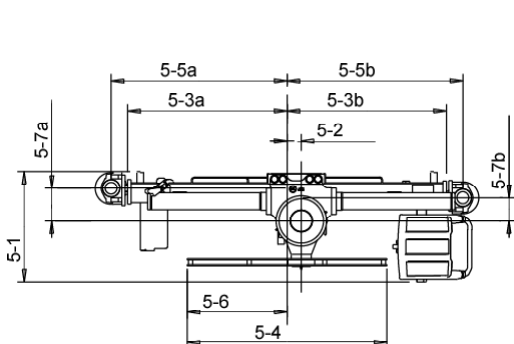

NOTE For specific values, see Table of Measurements

Chassis Installation

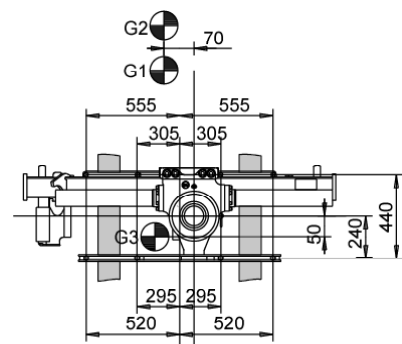

(1) Variable value depending on option.
 (2) Variations may occur depending on mounting position.

Load Diagram

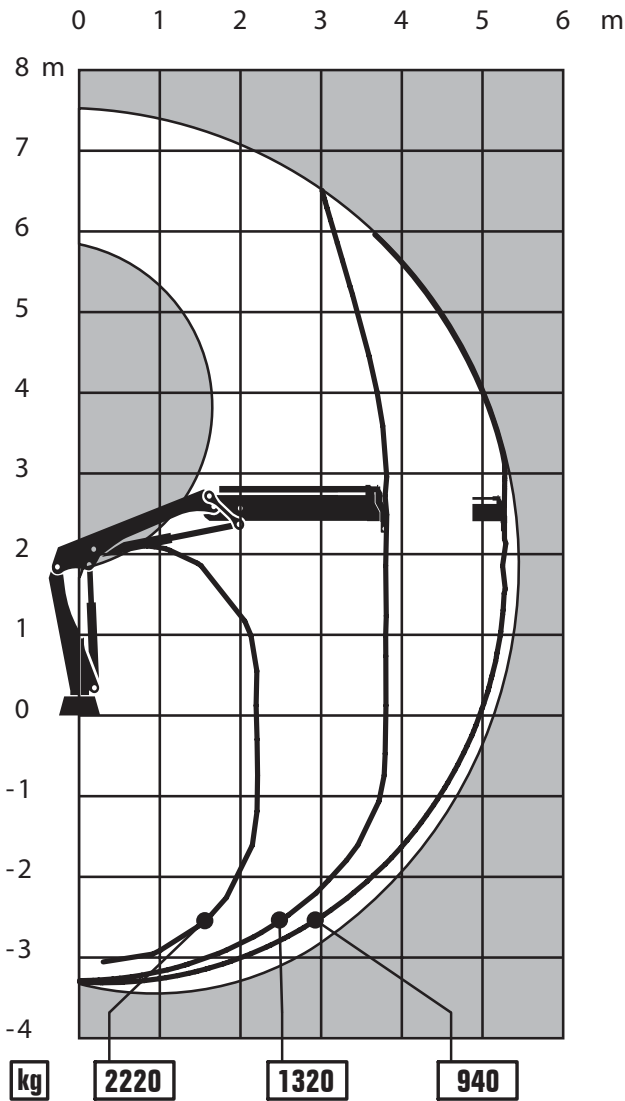

Capacity and performance

Lifting capacity	49 (kNm)
Standard lifting capacity at standard outreach	2.2 (m) - 2220 (kg)
	3.8 (m) - 1320 (kg)
	5.3 (m) - 940 (kg)
Manual lifting capacity at extension	7.2 (m) - 660 (kg)
	9.3 (m) - 480 (kg)
Hydraulic boom extension	1.7 (m)
Lifting height above installation level hydraulic	7.5 (m)
Slewing torque	7.7 (kNm)
V80 Slewing speed	15 (°/s)
Slewing angle	410 (°)
Lifting speed	1.0 (m/s)

Functional demands

Recommended oilflow low	25 (l/min)
Recommended oilflow high	30 (l/min)
Working pressure	24 (MPa)
Max slope viable at full capacity	5 (°)

Oil in tank	35 (l)
Tank capacity	40 (l)

Weights and measurements

Height in folded position	1900 (mm)
Width in folded position	1935 (mm)
Installation space needed	650 (mm)
Weight of crane	740 (kg)
Weight control stations (platform & top seat)	30 (kg)
Weight hose- and pipe kit	30 (kg)

Side View Unfolded Close in Area

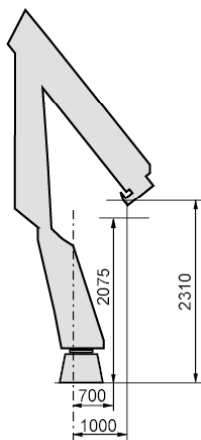

Side View Unfolded Stretched

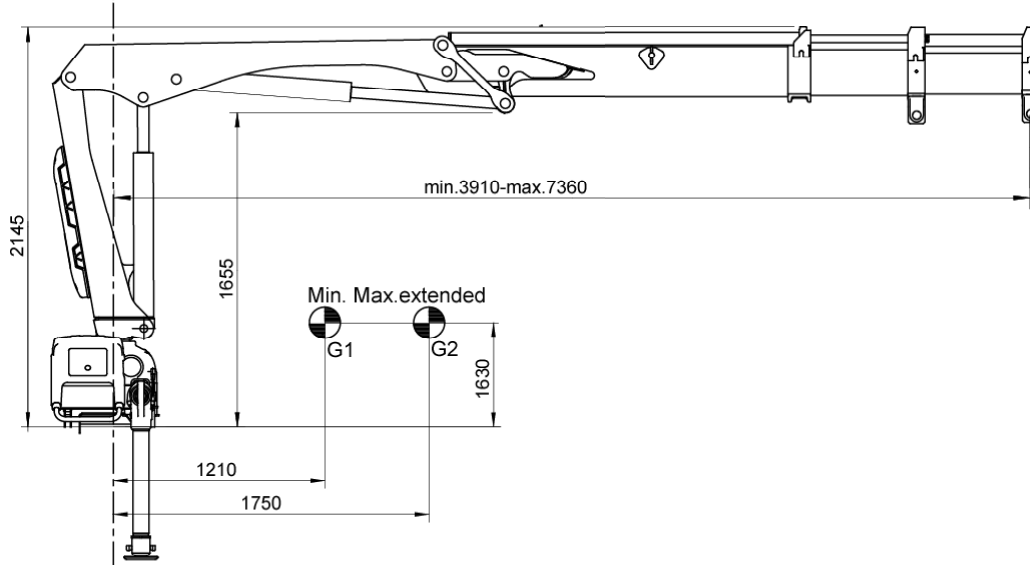

Side View Folded

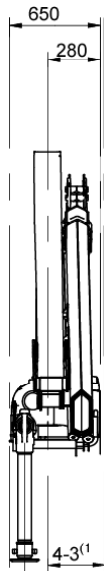

Front View Folded

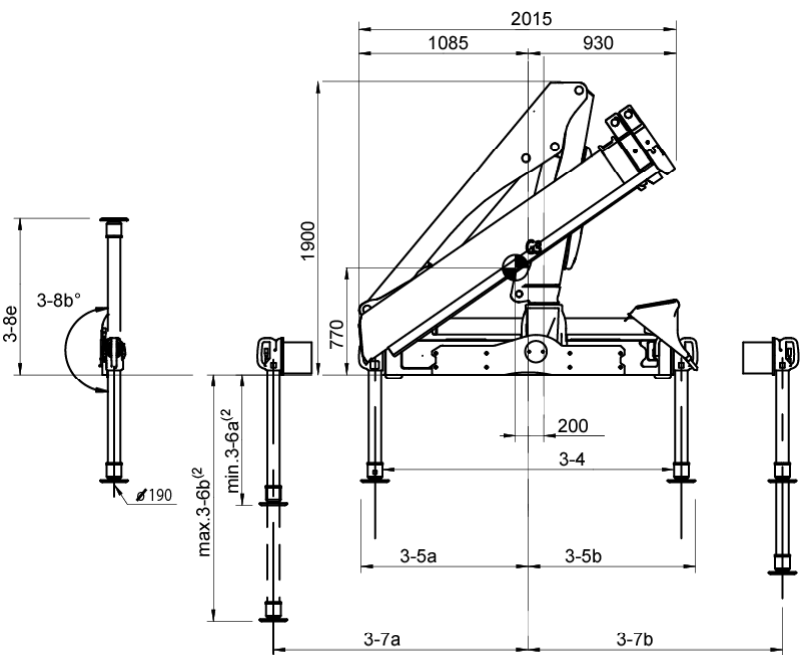

NOTE For specific values, see Table of Measurements

Top View Crane Base

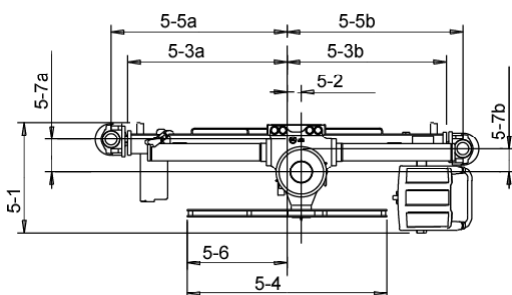

NOTE For specific values, see Table of Measurements

Chassis Installation

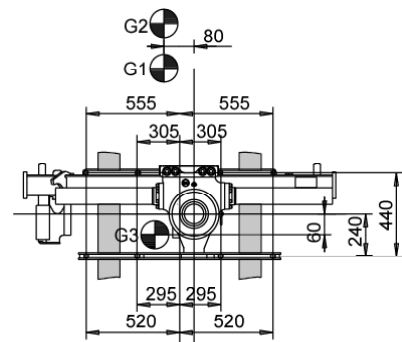

(1) Variable value depending on option.
 (2) Variations may occur depending on mounting position.

Load Diagram

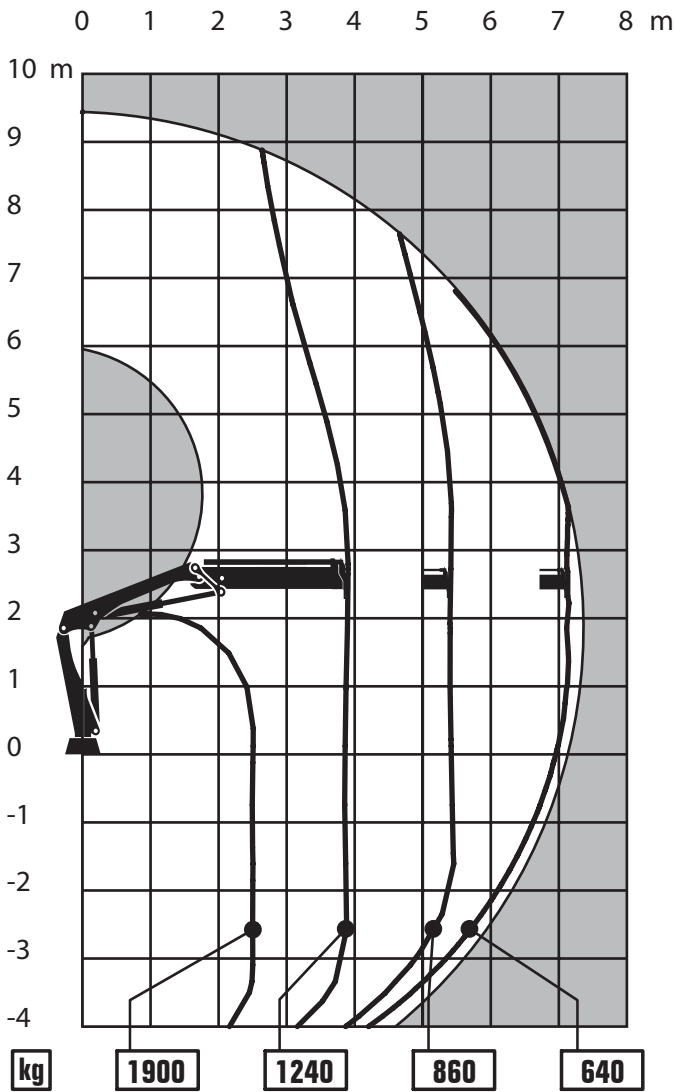

Capacity and performance

Lifting capacity	47 (kNm)
Standard lifting capacity at standard outreach	2.5 (m) - 1900 (kg)
	3.9 (m) - 1240 (kg)
	5.4 (m) - 860 (kg)
	7.2 (m) - 640 (kg)
Manual lifting capacity at extension	9.3 (m) - 460 (kg)
	11.2 (m) - 350 (kg)
Hydraulic boom extension	3.5 (m)
Lifting height above installation level hydraulic	9.4 (m)
Slewing torque	7.7 (kNm)
V80 Slewing speed	15 (°/s)
Slewing angle	410 (°)
Lifting speed	1.3 (m/s)

Functional demands

Recommended oilflow low	25 (l/min)
Recommended oilflow high	30 (l/min)
Working pressure	24 (MPa)
Max slope viable at full capacity	5 (°)
Oil in tank	35 (l)
Tank capacity	40 (l)

Weights and measurements

Height in folded position	1900 (mm)
Width in folded position	2015 (mm)
Installation space needed	650 (mm)
Weight of crane	820 (kg)
Weight control stations (platform & top seat)	30 (kg)
Weight hose- and pipe kit	35 (kg)

Side View Unfolded Close in Area

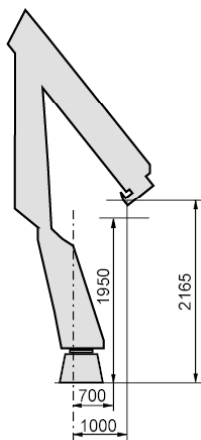

Side View Unfolded Stretched

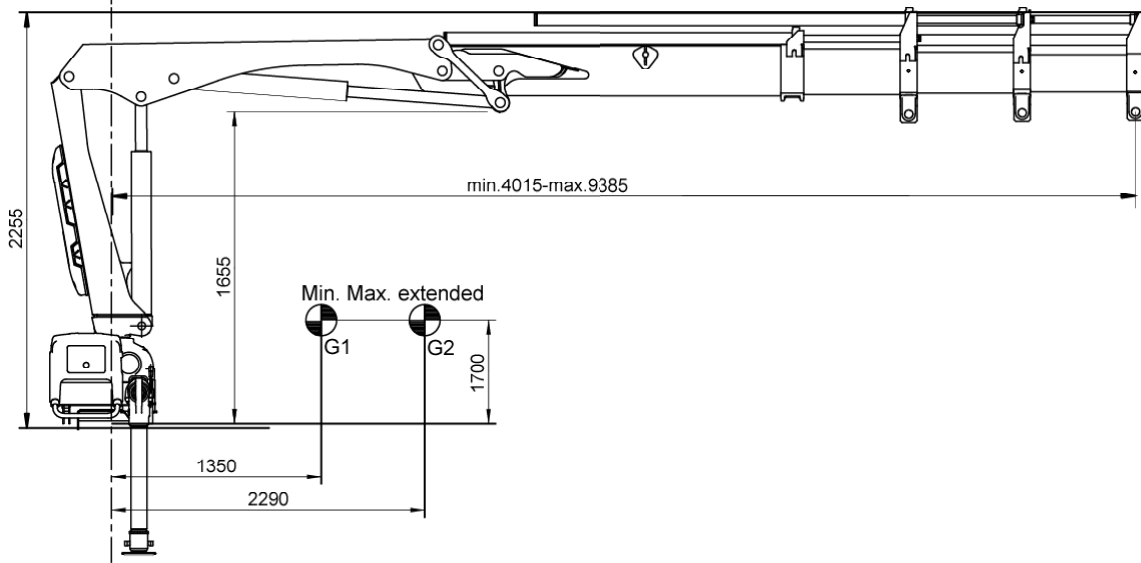

Side View Folded



Front View Folded

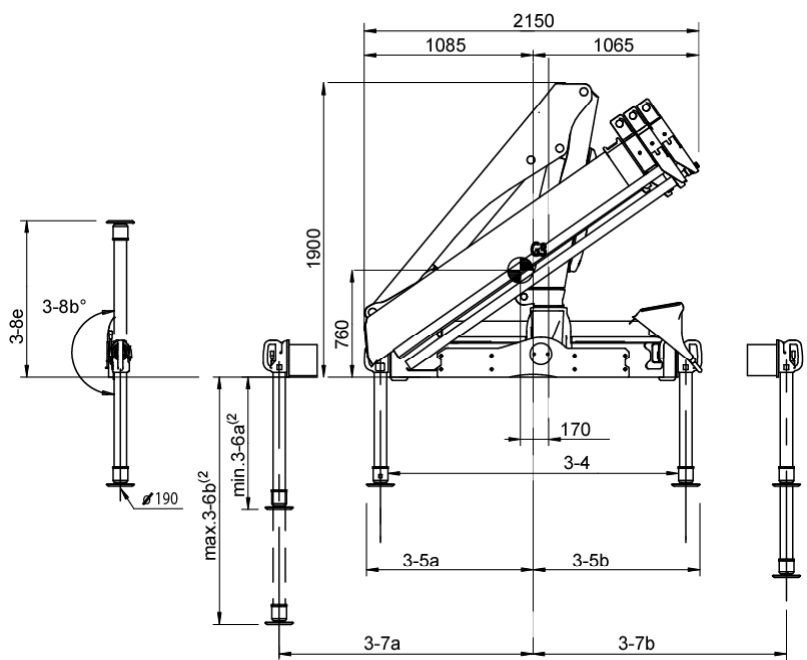

NOTE For specific values, see Table of Measurements

Top View Crane Base

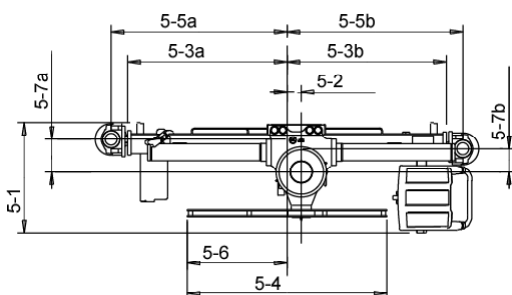

NOTE For specific values, see Table of Measurements

Chassis Installation

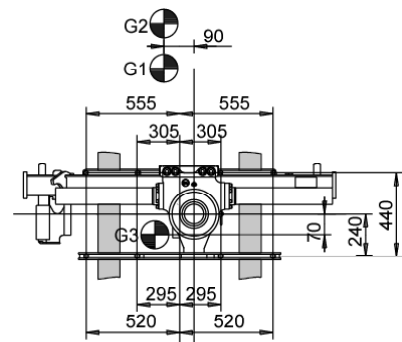

(1) Variable value depending on option.
 (2) Variations may occur depending on mounting position.

Load Diagram

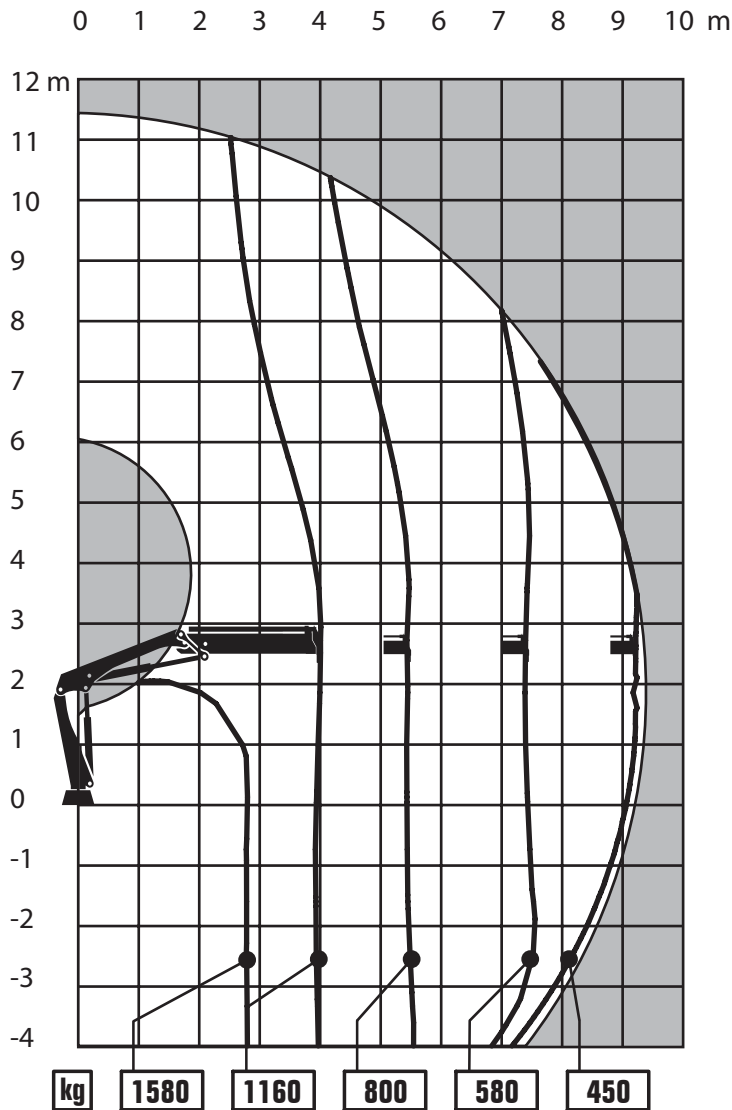

Capacity and performance

Lifting capacity	46 (kNm)
Standard lifting capacity at standard outreach	2.9 (m) - 1580 (kg)
	4.0 (m) - 1160 (kg)
	5.5 (m) - 800 (kg)
	7.3 (m) - 580 (kg)
	9.3 (m) - 450 (kg)
Manual lifting capacity at extension	11.2 (m) - 340 (kg)
Hydraulic boom extension	5.4 (m)
Lifting height above installation level hydraulic	11.5 (m)
Slewing torque	7.7 (kNm)
V80 Slewing speed	15 (°/s)
Slewing angle	410 (°)
Lifting speed	1.7 (m/s)

Functional demands

Recommended oilflow low	25 (l/min)
Recommended oilflow high	30 (l/min)
Working pressure	24 (MPa)
Max slope viable at full capacity	5 (°)
Oil in tank	65 (l)
Tank capacity	75 (l)

Weights and measurements

Height in folded position	1900 (mm)
Width in folded position	2150 (mm)
Installation space needed	650 (mm)
Weight of crane	880 (kg)
Weight control stations (platform & top seat)	30 (kg)

Side View Unfolded Close in Area

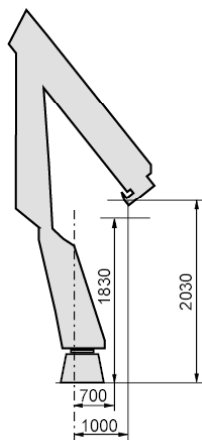

Side View Unfolded Stretched

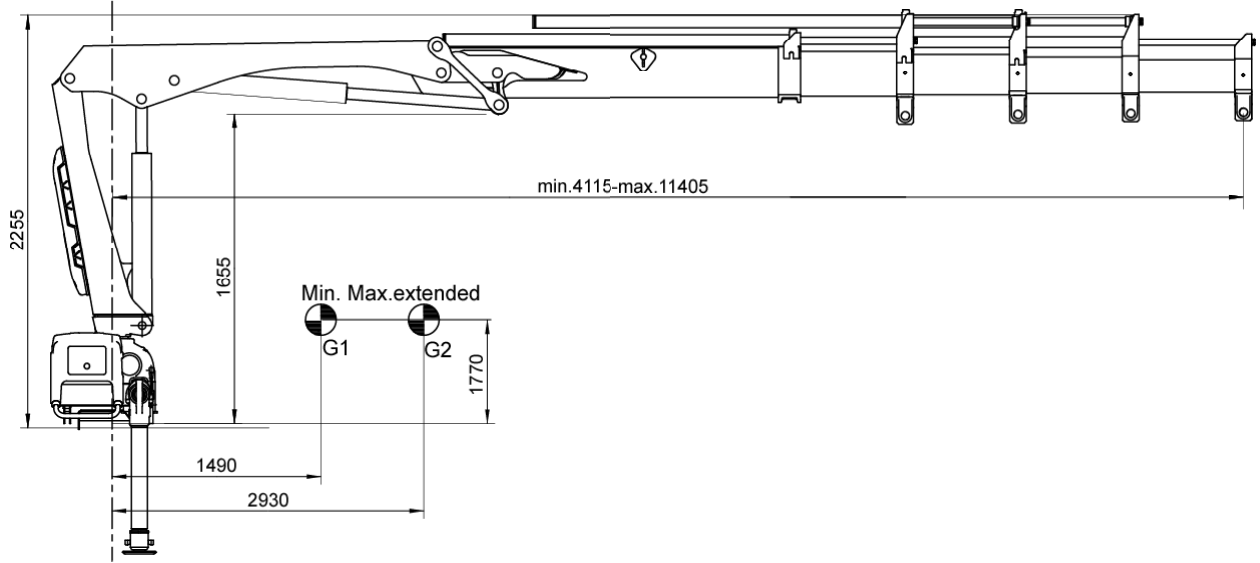

Side View Folded



Front View Folded

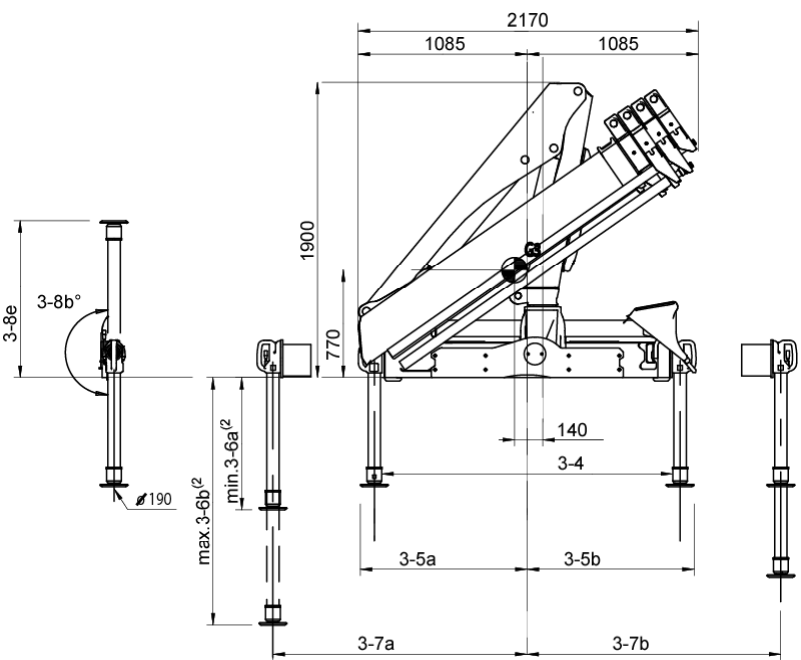

NOTE For specific values, see Table of Measurements

Top View Crane Base

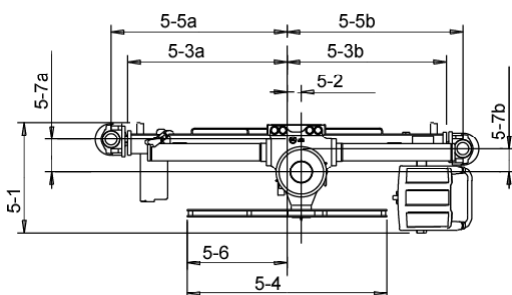

NOTE For specific values, see Table of Measurements

Chassis Installation

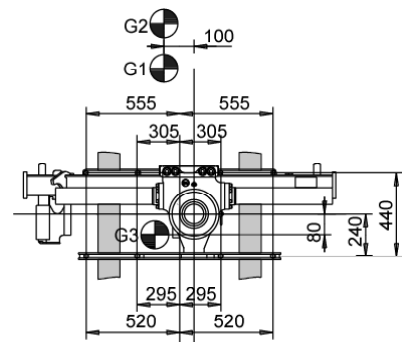

(1) Variable value depending on option.
 (2) Variations may occur depending on mounting position.

Load Diagram

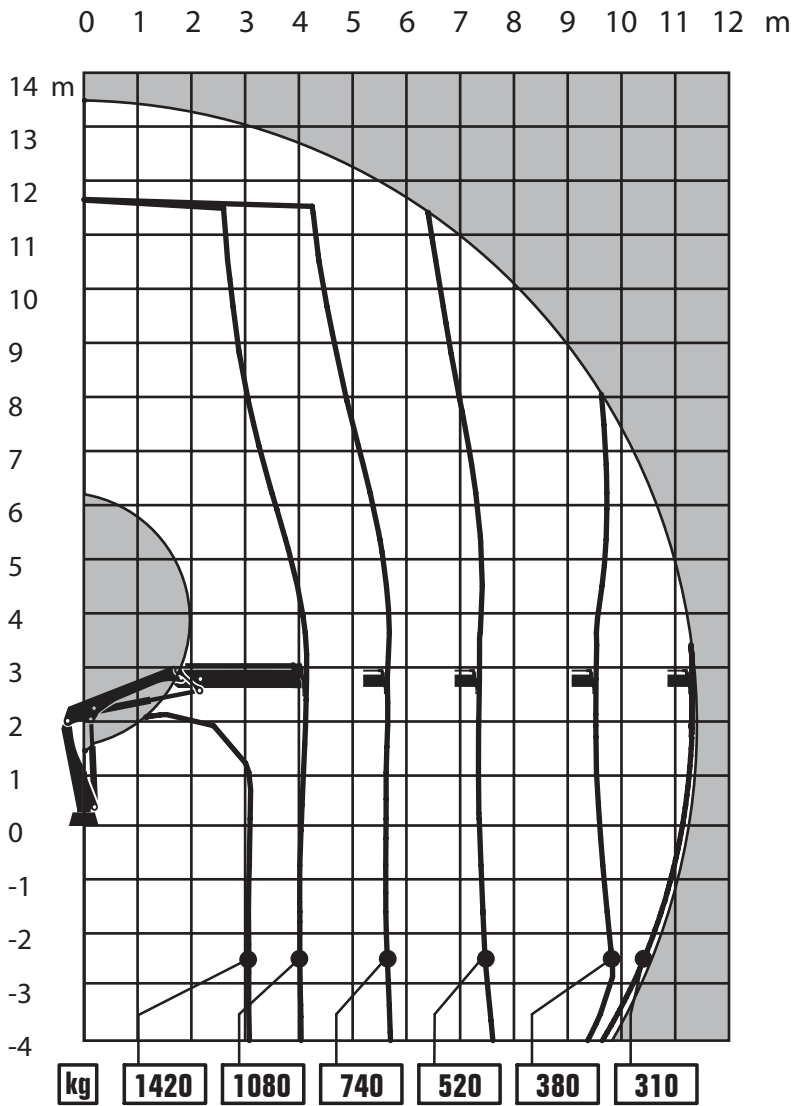

Capacity and performance

Lifting capacity	43 (kNm)
Standard lifting capacity at standard outreach	3.1 (m) - 1420 (kg)
	4.1 (m) - 1080 (kg)
	5.6 (m) - 740 (kg)
	7.4 (m) - 520 (kg)
	9.4 (m) - 380 (kg)
11.3 (m) - 310 (kg)	

Hydraulic boom extension	7.3 (m)
Lifting height above installation level hydraulic	13.5 (m)
Slewing torque	7.7 (kNm)
V80 Slewing speed	15 (°/s)
Slewing angle	410 (°)
Lifting speed	2.1 (m/s)

Functional demands

Recommended oilflow low	25 (l/min)
Recommended oilflow high	30 (l/min)
Working pressure	24 (MPa)
Max slope viable at full capacity	5 (°)
Oil in tank	65 (l)
Tank capacity	75 (l)

Weights and measurements

Height in folded position	1900 (mm)
Width in folded position	2170 (mm)
Installation space needed	650 (mm)
Weight of crane	950 (kg)
Weight control stations (platform & top seat)	30 (kg)

Side View Unfolded Close in Area

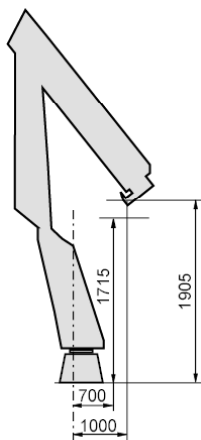

Side View Unfolded Stretched

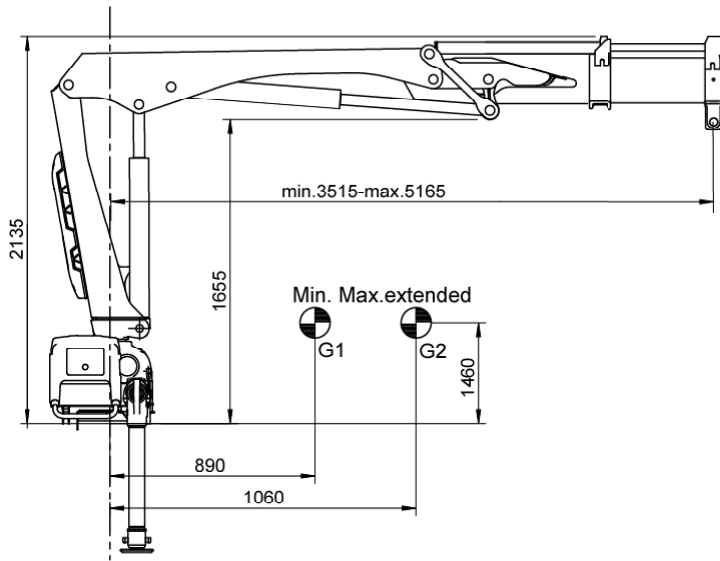

Side View Folded



Front View Folded

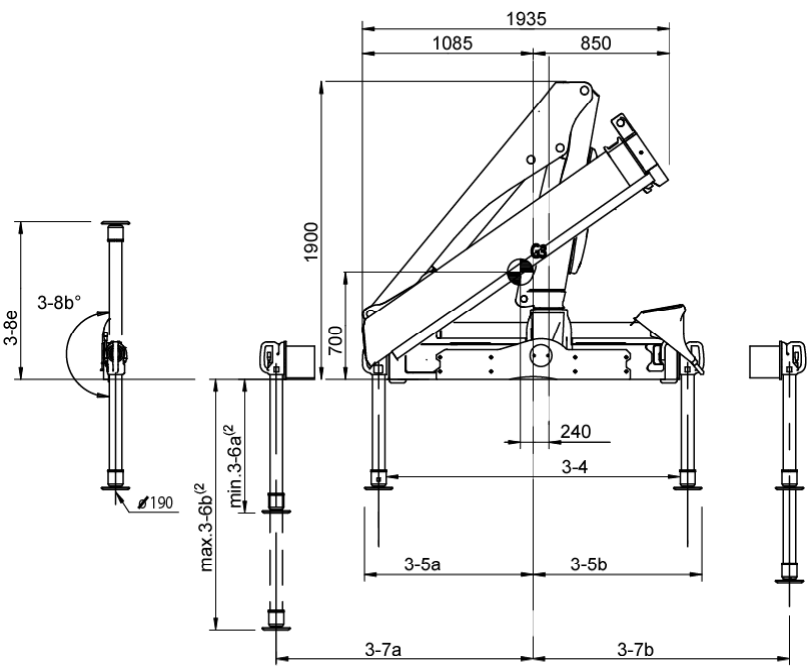

NOTE For specific values, see Table of Measurements

Top View Crane Base

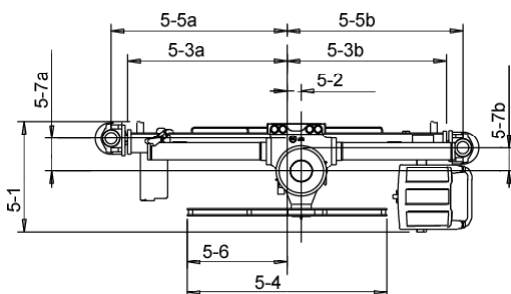

NOTE For specific values, see Table of Measurements

Chassis Installation

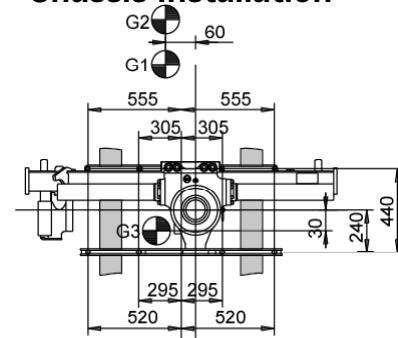

(1) Variable value depending on option.
 (2) Variations may occur depending on mounting position.

Load Diagram

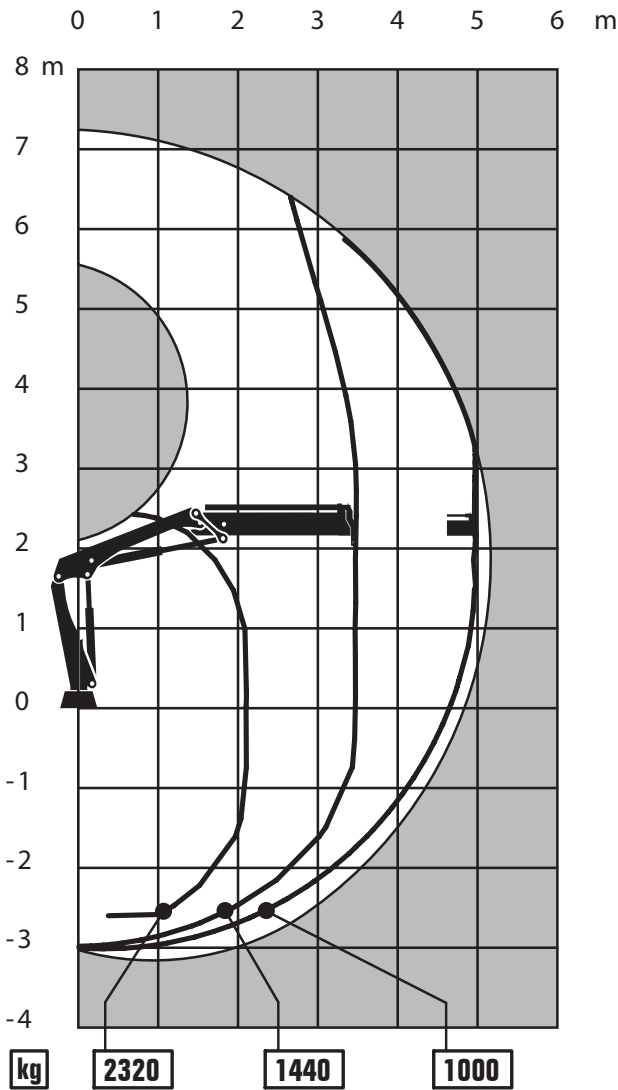

Capacity and performance

Lifting capacity	49 (kNm)
Standard lifting capacity at standard outreach	2.1 (m) - 2320 (kg)
	3.5 (m) - 1440 (kg)
	5.0 (m) - 1000 (kg)
Manual lifting capacity at extension	6.9 (m) - 700 (kg)
	9.0 (m) - 500 (kg)

Hydraulic boom extension	1.7 (m)
Lifting height above installation level hydraulic	7.2 (m)
Slewing torque	7.7 (kNm)
V80 Slewing speed	15 (°/s)
Slewing angle	410 (°)
Lifting speed	1.0 (m/s)

Functional demands

Recommended oilflow low	25 (l/min)
Recommended oilflow high	30 (l/min)
Working pressure	24 (MPa)
Max slope viable at full capacity	5 (°)
Oil in tank	65 (l)
Tank capacity	75 (l)

Weights and measurements

Height in folded position	1900 (mm)
Width in folded position	1935 (mm)
Installation space needed	650 (mm)
Weight of crane	740 (kg)
Weight control stations (platform & top seat)	30 (kg)
Weight hose- and pipe kit	30 (kg)

Side View Unfolded Close in Area

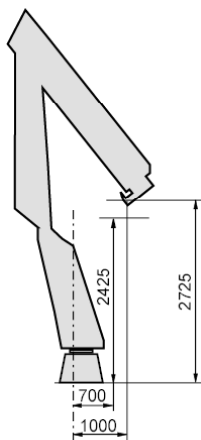

Side View Unfolded Stretched

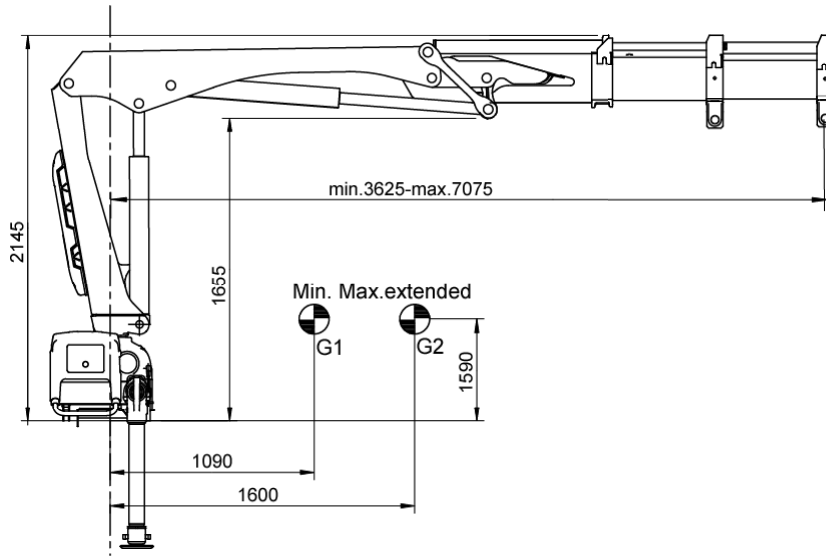

Side View Folded

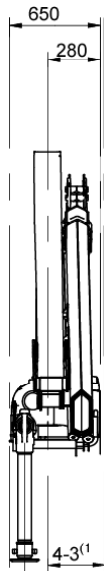

Front View Folded

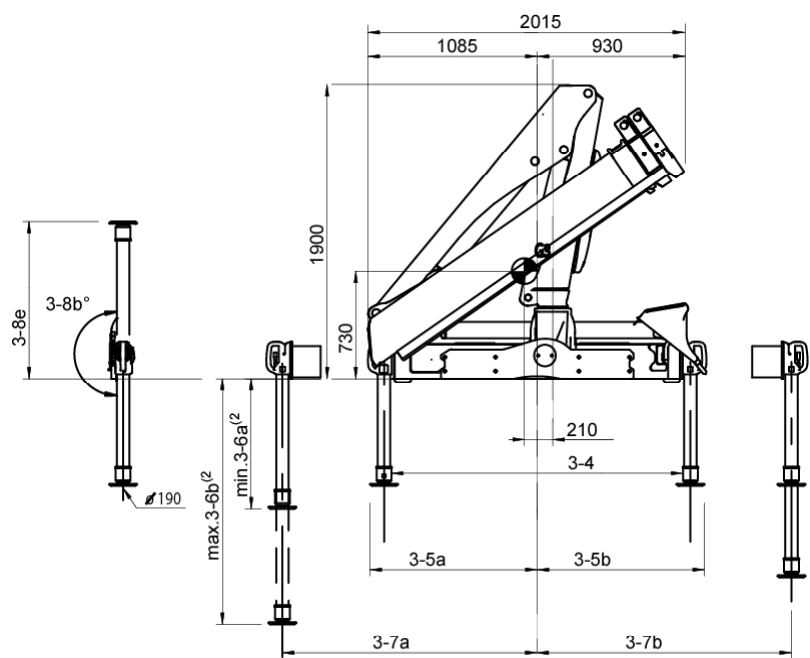

NOTE For specific values, see Table of Measurements

Top View Crane Base

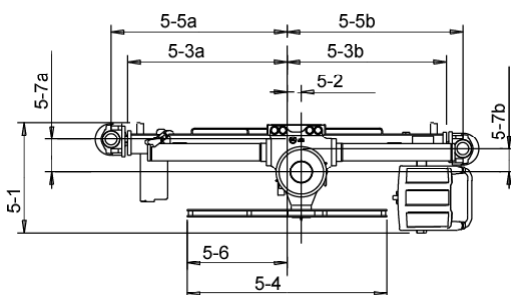

NOTE For specific values, see Table of Measurements

Chassis Installation

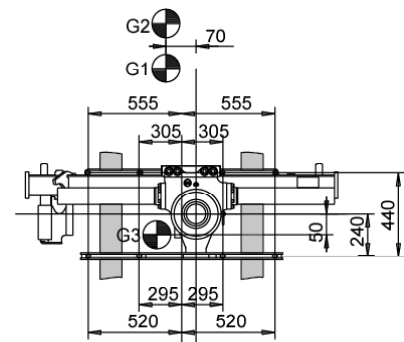

(1) Variable value depending on option.
 (2) Variations may occur depending on mounting position.

Load Diagram

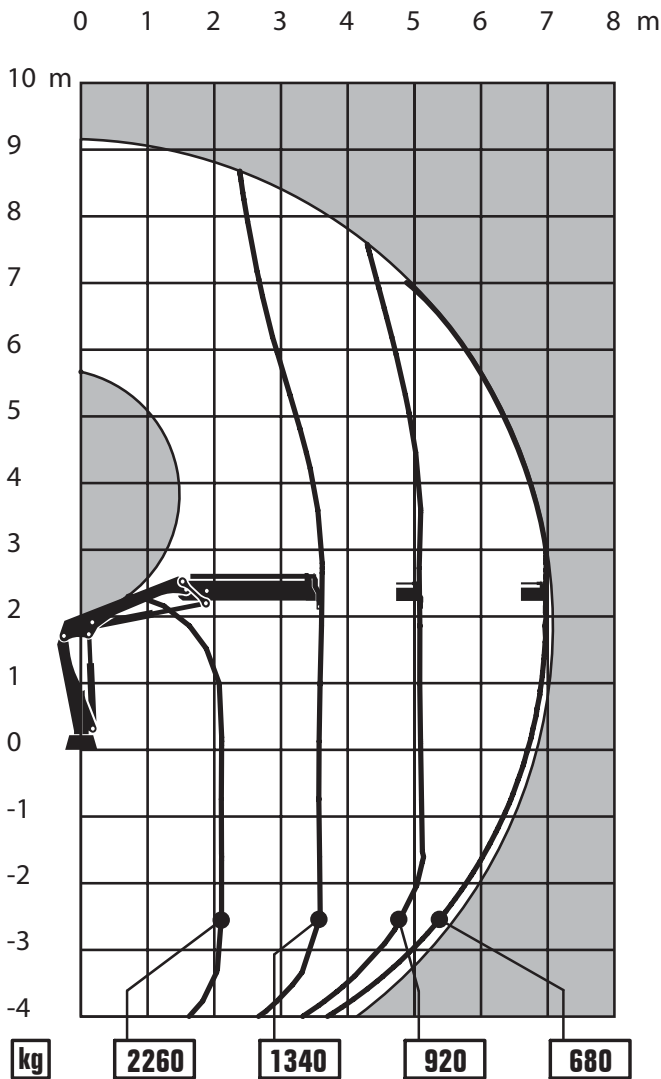

Capacity and performance

Lifting capacity	47 (kNm)
Standard lifting capacity at standard outreach	2.1 (m) - 2260 (kg)
	3.6 (m) - 1340 (kg)
	5.1 (m) - 920 (kg)
	6.9 (m) - 680 (kg)
Manual lifting capacity at extension	9.0 (m) - 480 (kg)
	11.0 (m) - 310 (kg)

Hydraulic boom extension	3.5 (m)
Lifting height above installation level hydraulic	9.2 (m)
Slewing torque	7.7 (kNm)
V80 Slewing speed	15 (°/s)
Slewing angle	410 (°)
Lifting speed	1.3 (m/s)

Functional demands

Recommended oilflow low	25 (l/min)
Recommended oilflow high	30 (l/min)
Working pressure	24 (MPa)
Max slope viable at full capacity	5 (°)
Oil in tank	65 (l)
Tank capacity	75 (l)

Weights and measurements

Height in folded position	1900 (mm)
Width in folded position	2015 (mm)
Installation space needed	650 (mm)
Weight of crane	810 (kg)
Weight control stations (platform & top seat)	30 (kg)
Weight hose- and pipe kit	35 (kg)

Side View Unfolded Close in Area

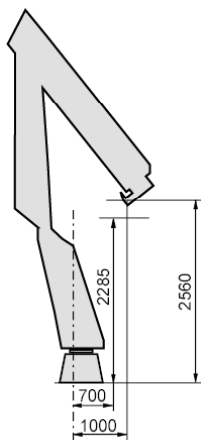

Side View Unfolded Stretched

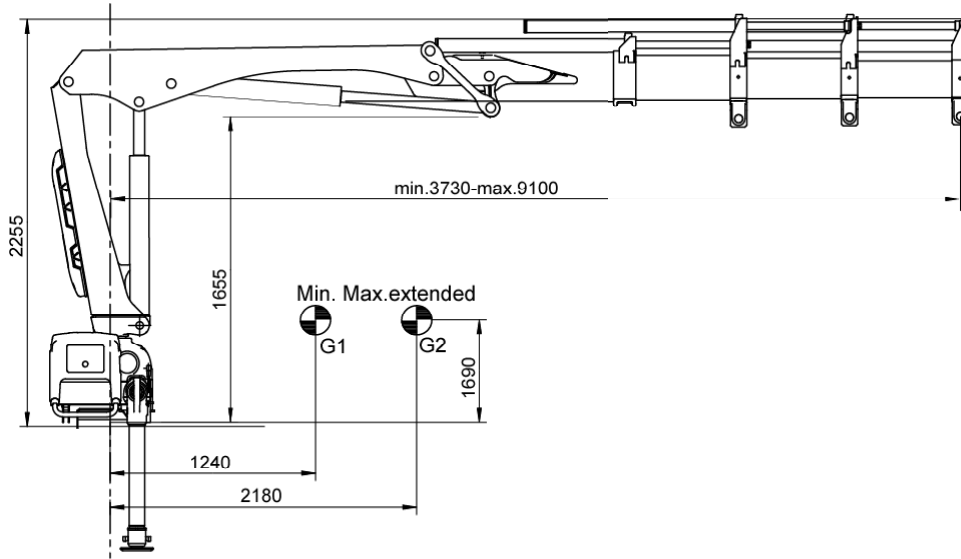

Side View Folded



Front View Folded

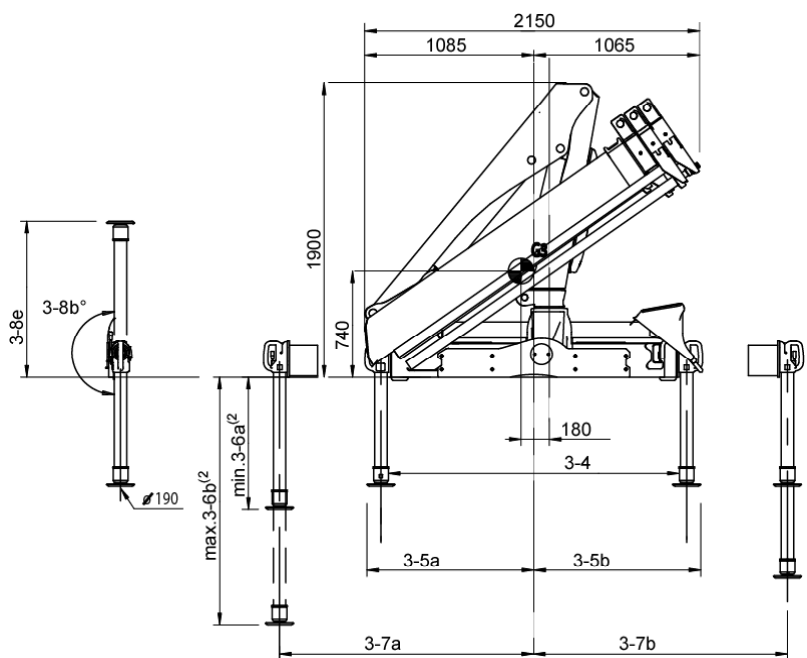

NOTE For specific values, see Table of Measurements

Top View Crane Base

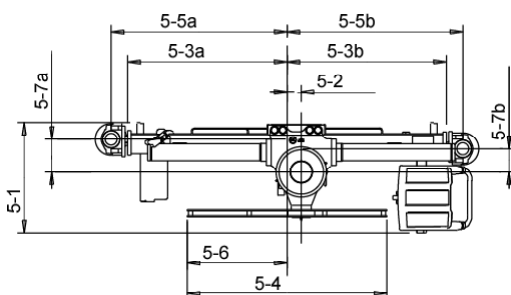

NOTE For specific values, see Table of Measurements

Chassis Installation

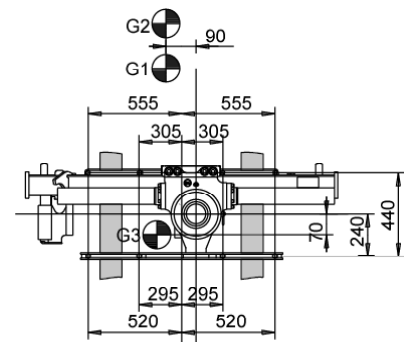

(1) Variable value depending on option.
 (2) Variations may occur depending on mounting position.

Load Diagram

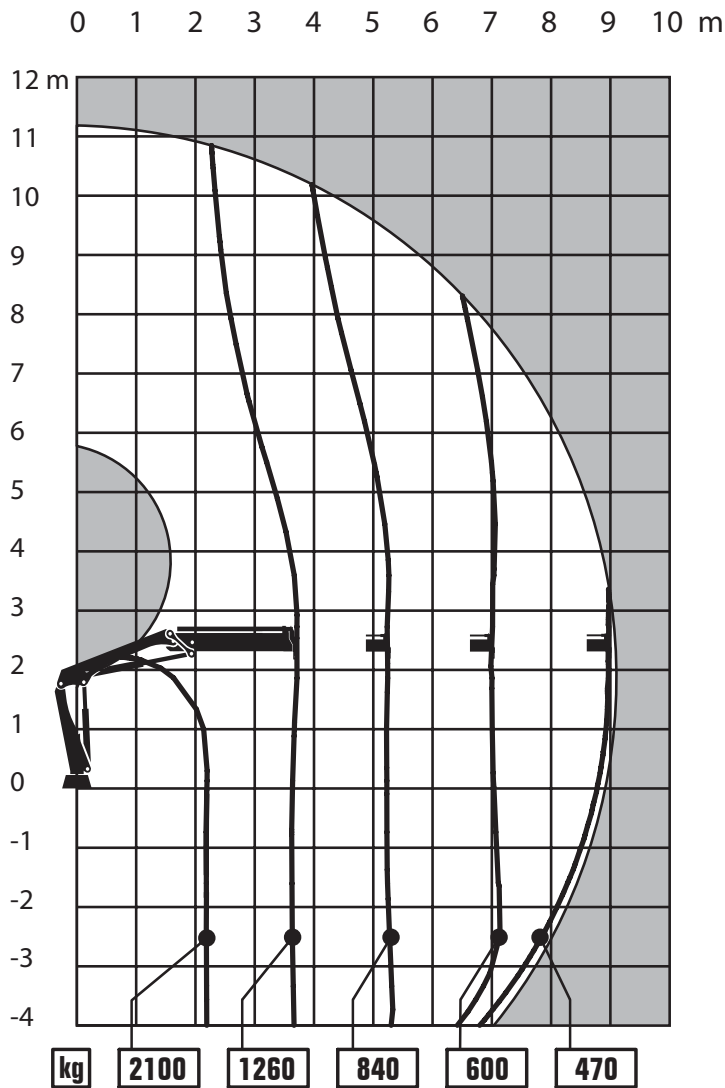

Capacity and performance

Lifting capacity	46 (kNm)
Standard lifting capacity at standard outreach	2.2 (m) - 2100 (kg)
	3.7 (m) - 1260 (kg)
	5.3 (m) - 840 (kg)
	7.1 (m) - 600 (kg)
	9.0 (m) - 470 (kg)
Manual lifting capacity at extension	11.0 (m) - 330 (kg)
Hydraulic boom extension	5.4 (m)
Lifting height above installation level hydraulic	11.2 (m)
Slewing torque	7.7 (kNm)
V80 Slewing speed	15 (°/s)
Slewing angle	410 (°)
Lifting speed	1.7 (m/s)

Functional demands

Recommended oilflow low	25 (l/min)
Recommended oilflow high	30 (l/min)
Working pressure	24 (MPa)
Max slope viable at full capacity	5 (°)
Oil in tank	65 (l)
Tank capacity	75 (l)

Weights and measurements

Height in folded position	1900 (mm)
Width in folded position	2150 (mm)
Installation space needed	650 (mm)
Weight of crane	880 (kg)
Weight control stations (platform & top seat)	30 (kg)

Side View Unfolded Close in Area

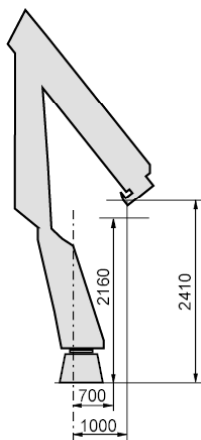

Side View Unfolded Stretched

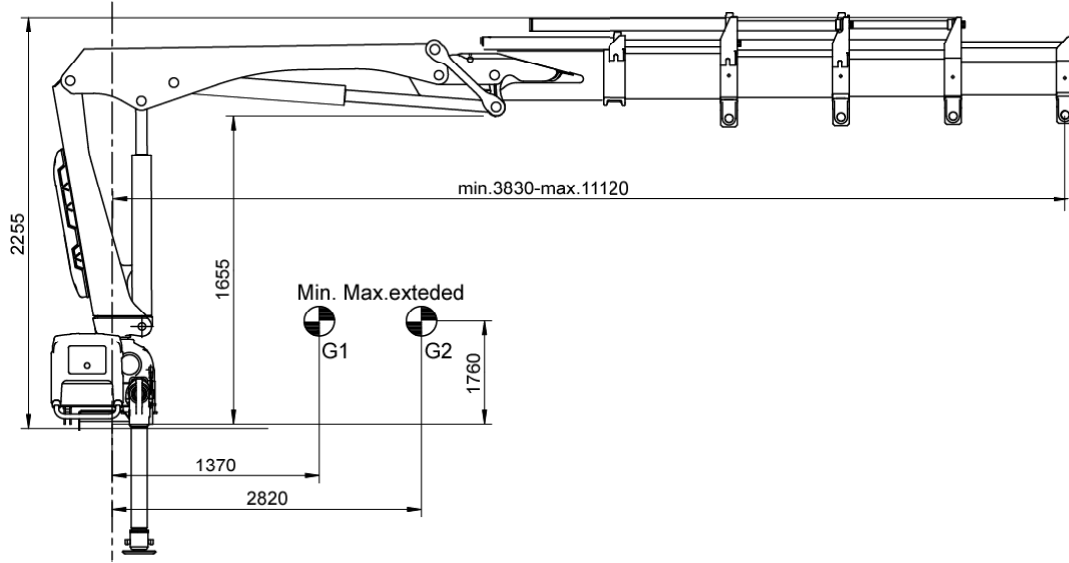

Side View Folded



Front View Folded

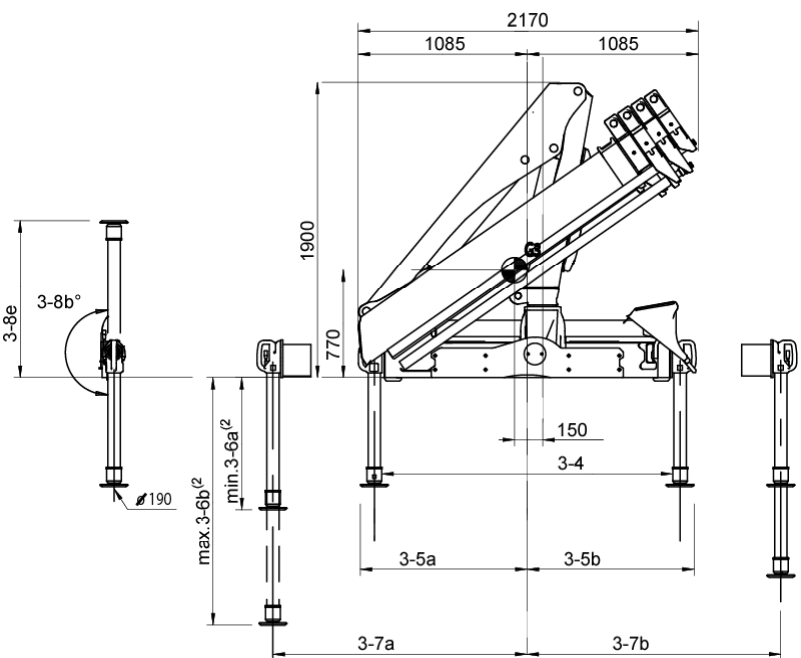

NOTE For specific values, see Table of Measurements

Top View Crane Base

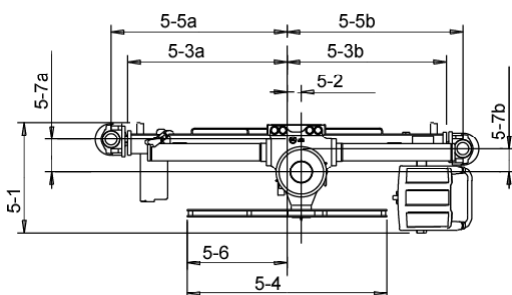

NOTE For specific values, see Table of Measurements

Chassis Installation

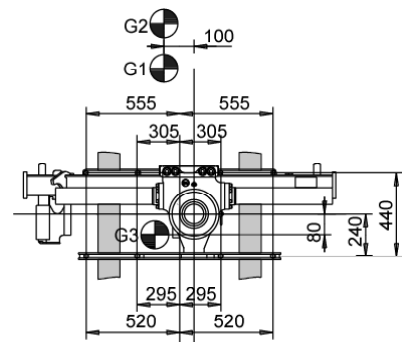

(1) Variable value depending on option.
 (2) Variations may occur depending on mounting position.

Load Diagram

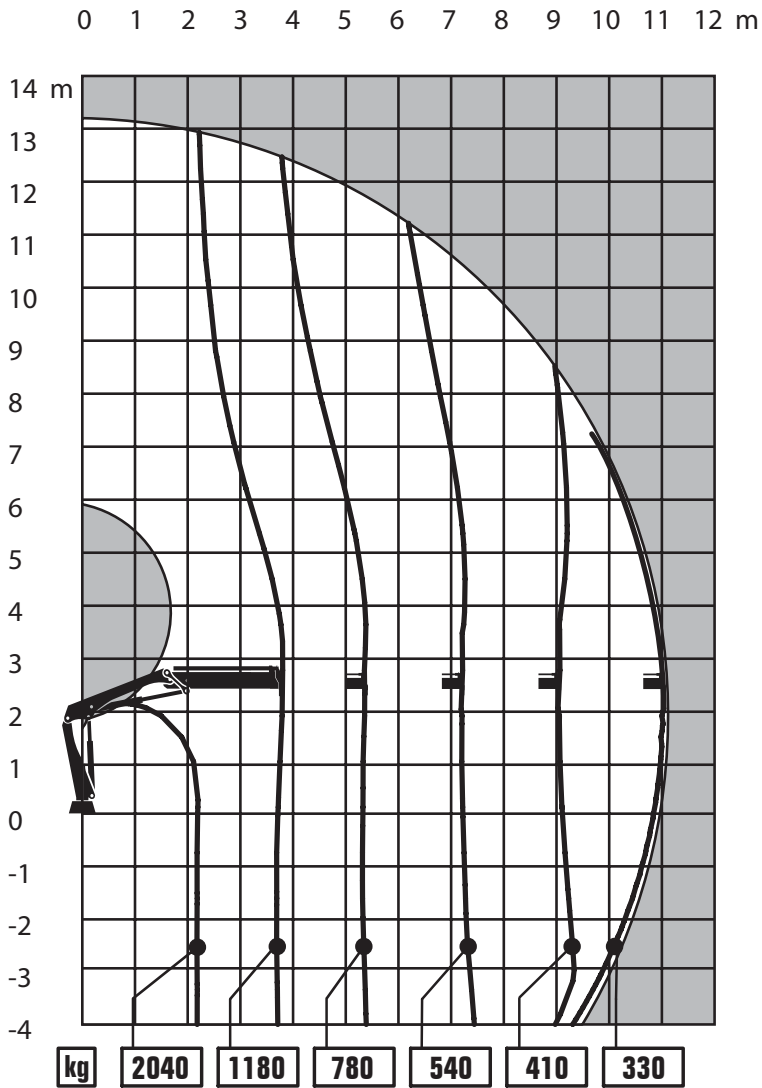

Capacity and performance

Lifting capacity	44 (kNm)
Standard lifting capacity at standard outreach	2.2 (m) - 2040 (kg)
	3.8 (m) - 1180 (kg)
	5.4 (m) - 780 (kg)
	7.2 (m) - 540 (kg)
	9.1 (m) - 410 (kg)
11.0 (m) - 330 (kg)	

Hydraulic boom extension 7.3 (m)

Lifting height above installation level hydraulic 13.2 (m)

Slewing torque 7.7 (kNm)

V80 Slewing speed 15 (°/s)

Slewing angle 410 (°)

Lifting speed 2.0 (m/s)

Functional demands

Recommended oilflow low 25 (l/min)

Recommended oilflow high 30 (l/min)

Working pressure 24 (MPa)

Max slope viable at full capacity 5 (°)

Oil in tank 65 (l)

Tank capacity 75 (l)

Weights and measurements

Height in folded position 1900 (mm)

Width in folded position 2170 (mm)

Installation space needed 650 (mm)

Weight of crane 940 (kg)

Weight control stations (platform & top seat) 30 (kg)

Side View Unfolded Close in Area

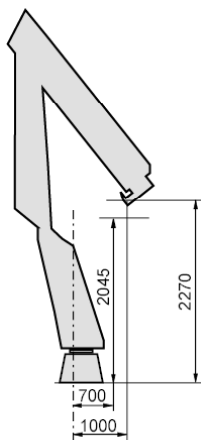

Side View Unfolded Stretched

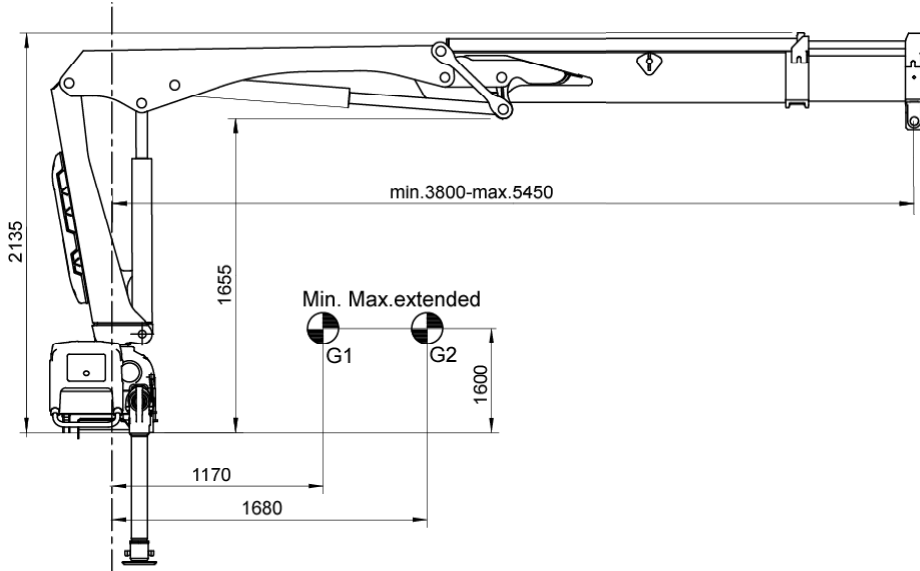

Side View Folded



Front View Folded

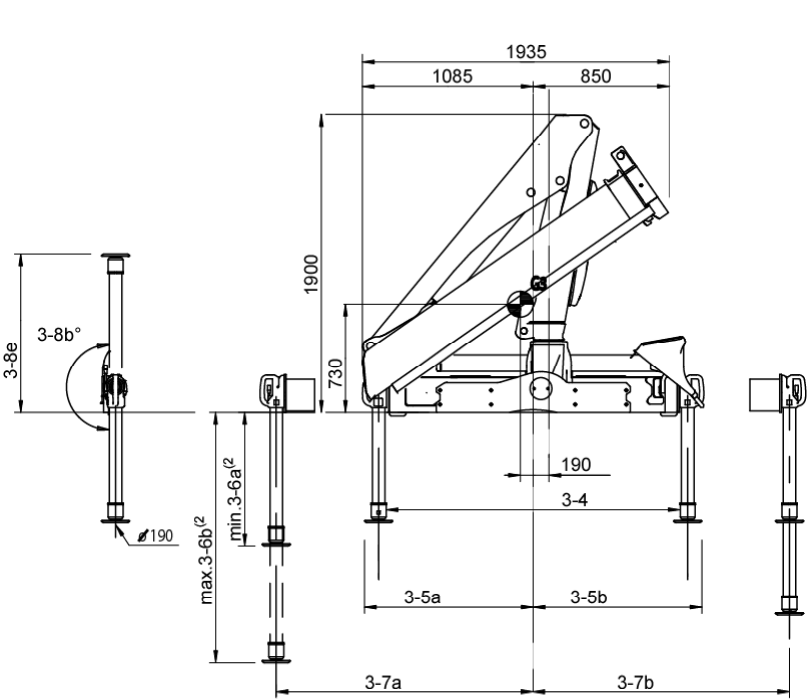

NOTE For specific values, see Table of Measurements

Top View Crane Base

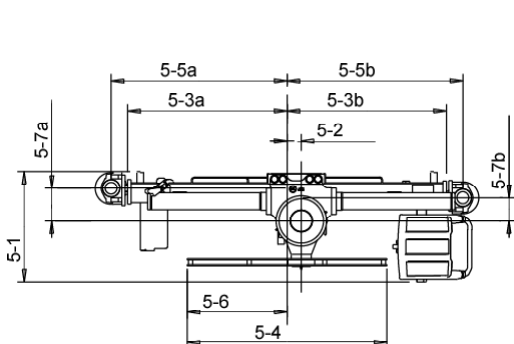

NOTE For specific values, see Table of Measurements

Chassis Installation

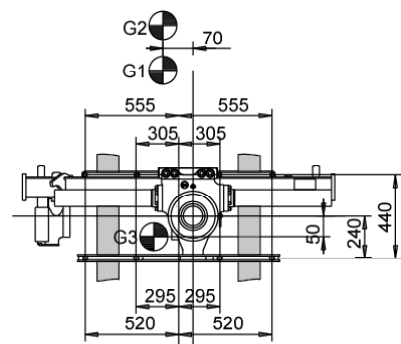

(1) Variable value depending on option.
 (2) Variations may occur depending on mounting position.

Load Diagram

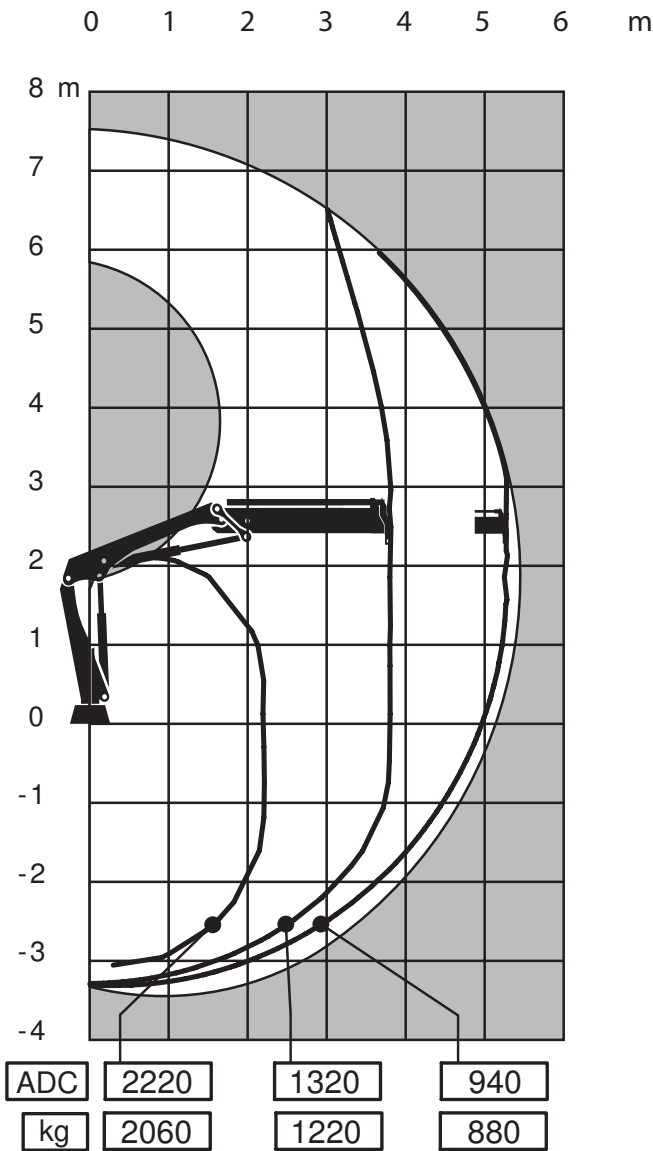

Side View Unfolded Close in Area

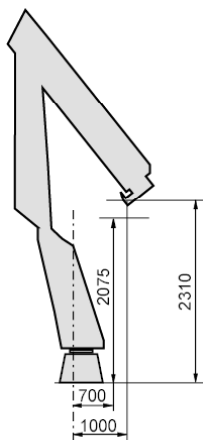

Capacity and performance

Lifting capacity with ADC	49	(kNm)
Lifting capacity	45	(kNm)
Standard lifting capacity at standard outreach with ADC	2.2 (m) - 2220 (kg)	
	3.8 (m) - 1320 (kg)	
	5.3 (m) - 940 (kg)	
Standard lifting capacity at standard outreach	2.2 (m) - 2060 (kg)	
	3.8 (m) - 1220 (kg)	
	5.3 (m) - 880 (kg)	
Manual lifting capacity at extension	7.2 (m) - 660 (kg)	
	9.3 (m) - 480 (kg)	
Hydraulic boom extension	1.7	(m)
Lifting height above installation level hydraulic	7.5	(m)
Slewing torque	7.7	(kNm)
V80 Slewing speed	15	(°/s)
Slewing angle	410	(°)
Lifting speed	1.0	(m/s)

Functional demands

Recommended oilflow low	25	(l/min)
Recommended oilflow high	30	(l/min)
Working pressure	24	(MPa)
Max slope viable at full capacity	5	(°)
Oil in tank	35	(l)
Tank capacity	40	(l)

Weights and measurements

Height in folded position	1900	(mm)
Width in folded position	1935	(mm)
Installation space needed	650	(mm)
Weight of crane	740	(kg)
Weight control stations (platform & top seat)	30	(kg)
Weight hose- and pipe kit	30	(kg)

Side View Unfolded Stretched

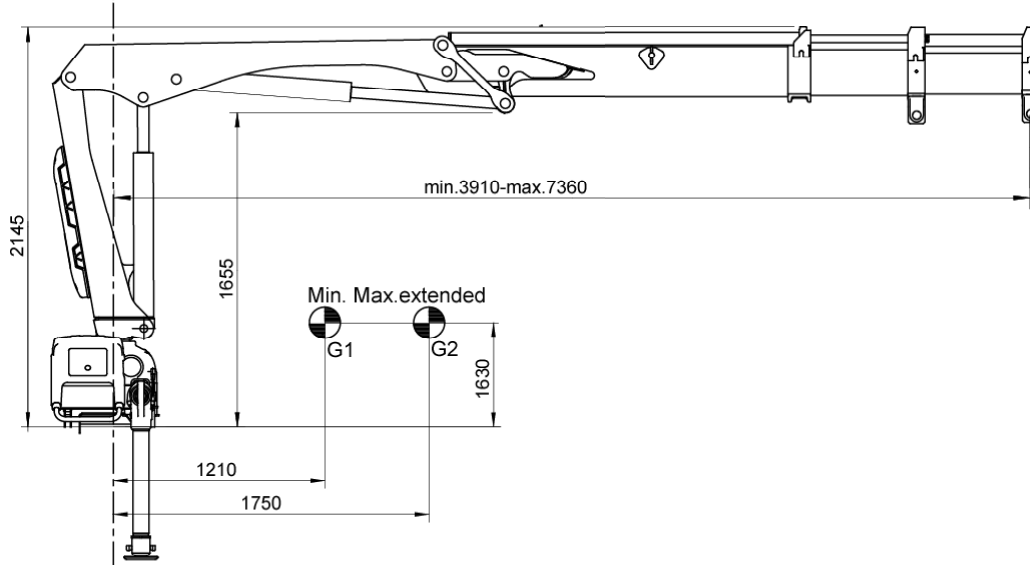

Side View Folded

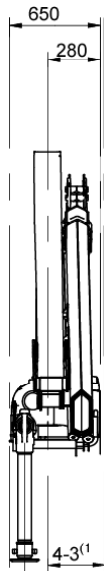

Front View Folded

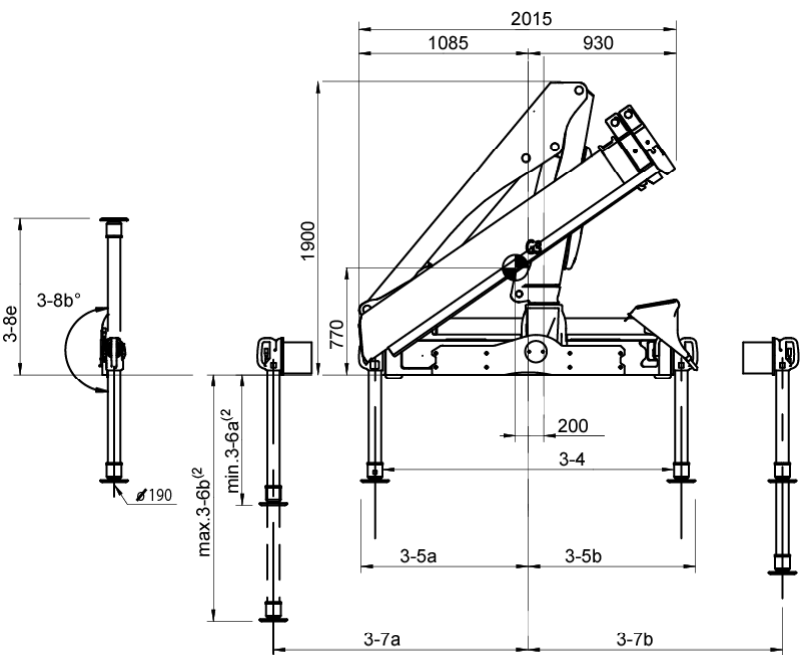

NOTE For specific values, see Table of Measurements

Top View Crane Base

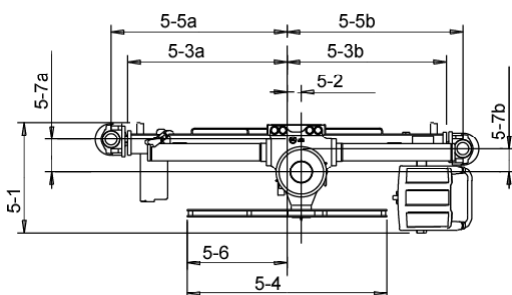

NOTE For specific values, see Table of Measurements

Chassis Installation

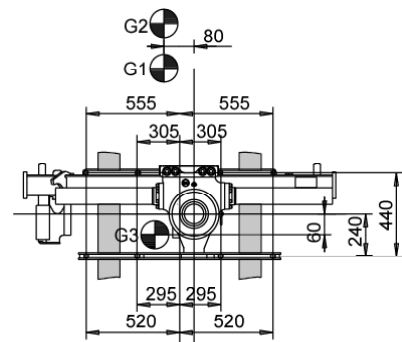

(1) Variable value depending on option.
 (2) Variations may occur depending on mounting position.

Load Diagram

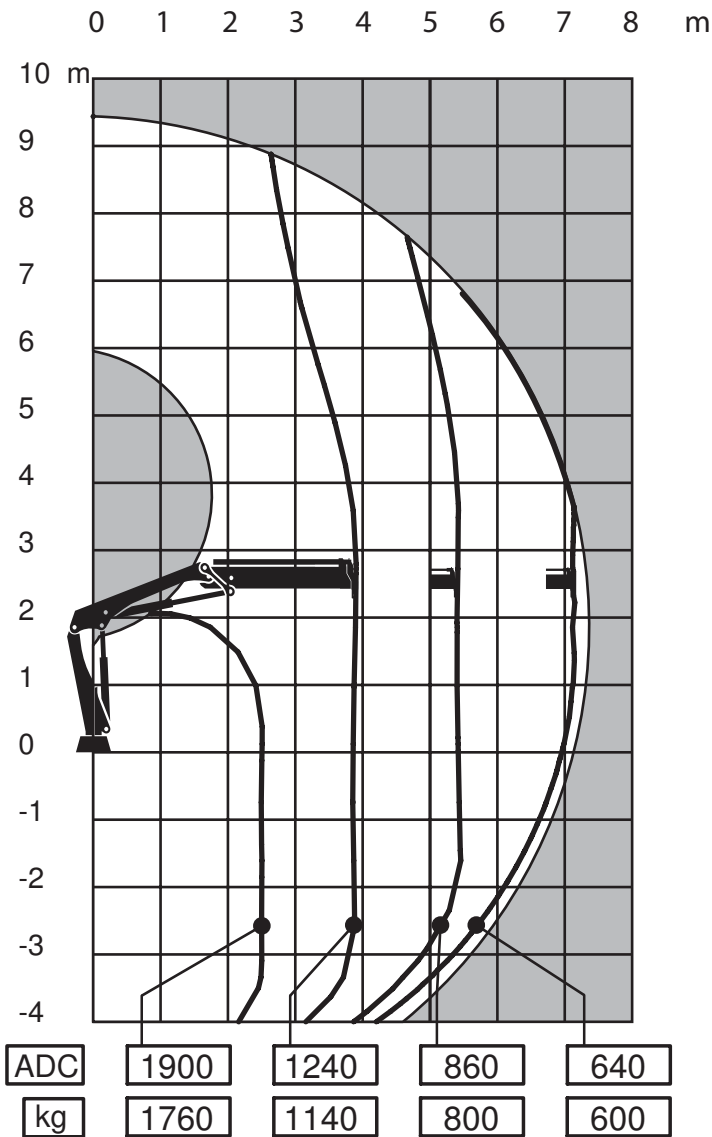

Capacity and performance

Lifting capacity with ADC	47	(kNm)
Lifting capacity	44	(kNm)
Standard lifting capacity at standard outreach with ADC	2.5 (m) - 1900 (kg)	
	3.9 (m) - 1240 (kg)	
	5.4 (m) - 860 (kg)	
	7.2 (m) - 640 (kg)	
Standard lifting capacity at standard outreach	2.5 (m) - 1760 (kg)	
	3.9 (m) - 1140 (kg)	
	5.4 (m) - 800 (kg)	
	7.2 (m) - 600 (kg)	
Manual lifting capacity at extension	9.3 (m) - 460 (kg)	
	11.2 (m) - 350 (kg)	
Hydraulic boom extension	3.5	(m)
Lifting height above installation level hydraulic	9.4	(m)
Slewing torque	7.7	(kNm)
V80 Slewing speed	15	(°/s)
Slewing angle	410	(°)
Lifting speed	1.3	(m/s)

Functional demands

Recommended oilflow low	25	(l/min)
Recommended oilflow high	30	(l/min)
Working pressure	24	(MPa)
Max slope viable at full capacity	5	(°)
Oil in tank	35	(l)
Tank capacity	40	(l)

Weights and measurements

Height in folded position	1900	(mm)
Width in folded position	2015	(mm)
Installation space needed	650	(mm)
Weight of crane	820	(kg)
Weight control stations (platform & top seat)	30	(kg)
Weight hose- and pipe kit	35	(kg)

Side View Unfolded Close in Area

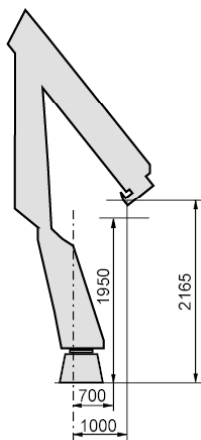

Side View Unfolded Stretched

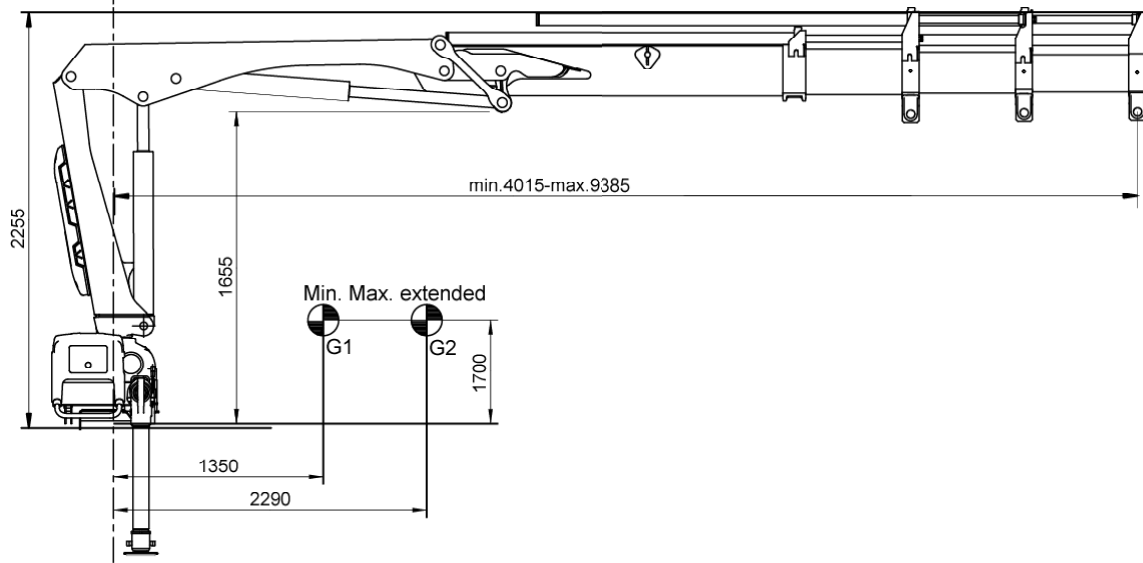

Side View Folded



Front View Folded

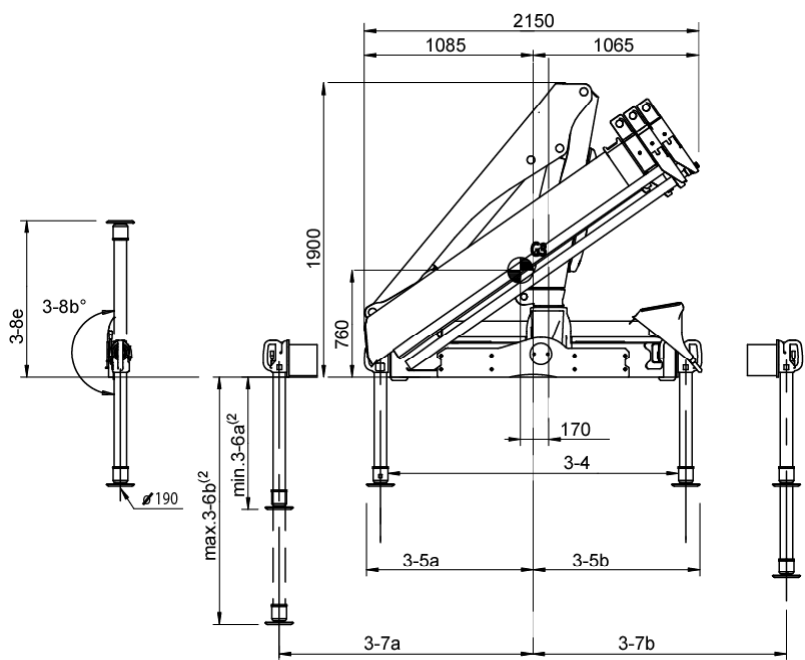

NOTE For specific values, see Table of Measurements

Top View Crane Base

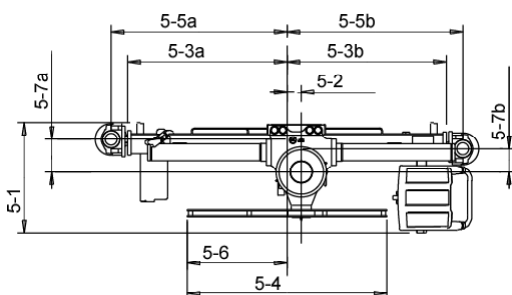

NOTE For specific values, see Table of Measurements

Chassis Installation

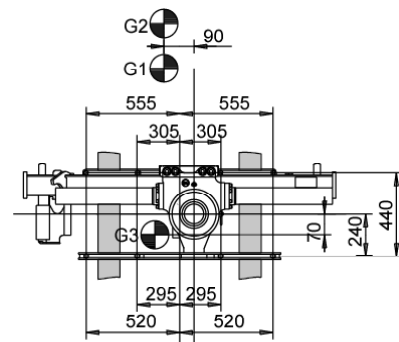

(1) Variable value depending on option.
 (2) Variations may occur depending on mounting position.

Load Diagram

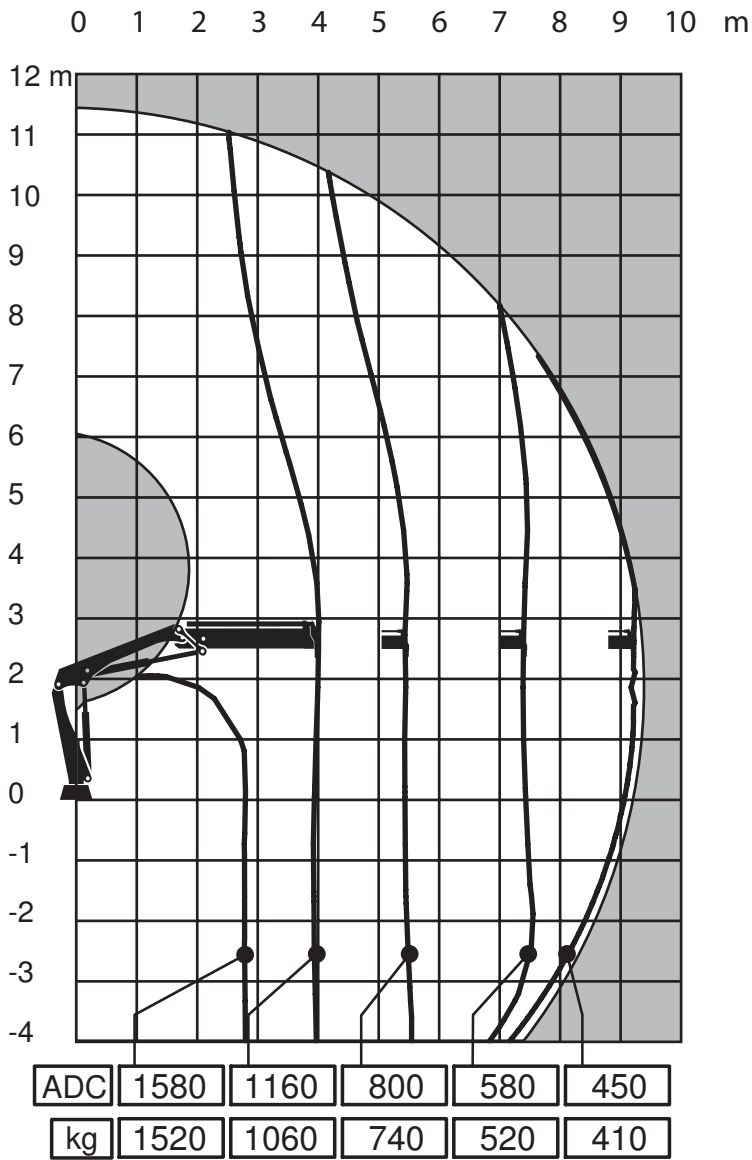

Side View Unfolded Close in Area

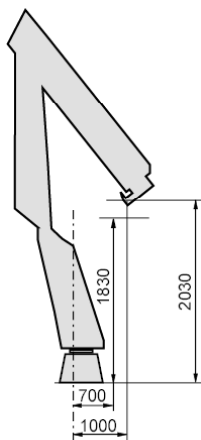

Capacity and performance

Lifting capacity with ADC	46	(kNm)
Lifting capacity	42	(kNm)
Standard lifting capacity at standard outreach with ADC	2.9 (m)	- 1580 (kg)
	4.0 (m)	- 1160 (kg)
	5.5 (m)	- 800 (kg)
	7.3 (m)	- 580 (kg)
	9.3 (m)	- 450 (kg)
Standard lifting capacity at standard outreach	2.9 (m)	- 1520 (kg)
	4.0 (m)	- 1060 (kg)
	5.5 (m)	- 740 (kg)
	7.3 (m)	- 520 (kg)
	9.3 (m)	- 410 (kg)
Manual lifting capacity at extension	11.2 (m)	- 340 (kg)
Hydraulic boom extension	5.4	(m)
Lifting height above installation level hydraulic	11.5	(m)
Slewing torque	7.7	(kNm)
V80 Slewing speed	15	(°/s)
Slewing angle	410	(°)
Lifting speed	1.7	(m/s)

Functional demands

Recommended oilflow low	25	(l/min)
Recommended oilflow high	30	(l/min)
Working pressure	24	(MPa)
Max slope viable at full capacity	5	(°)
Oil in tank	65	(l)
Tank capacity	75	(l)

Weights and measurements

Height in folded position	1900	(mm)
Width in folded position	2150	(mm)
Installation space needed	650	(mm)
Weight of crane	880	(kg)
Weight control stations (platform & top seat)	30	(kg)

Side View Unfolded Stretched

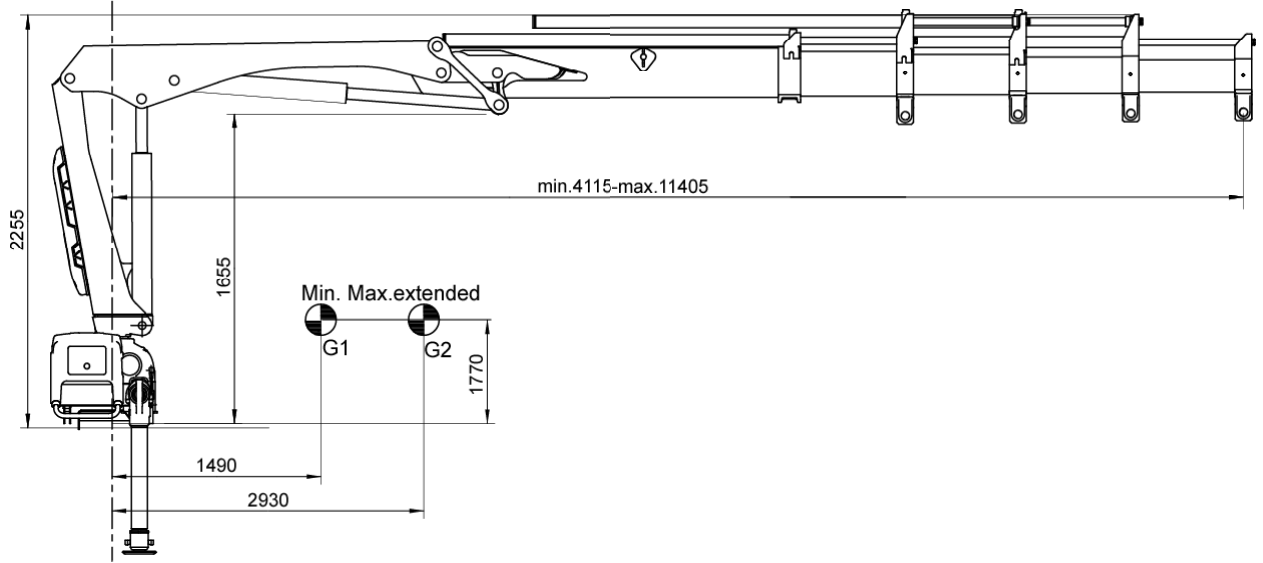

Side View Folded



Front View Folded

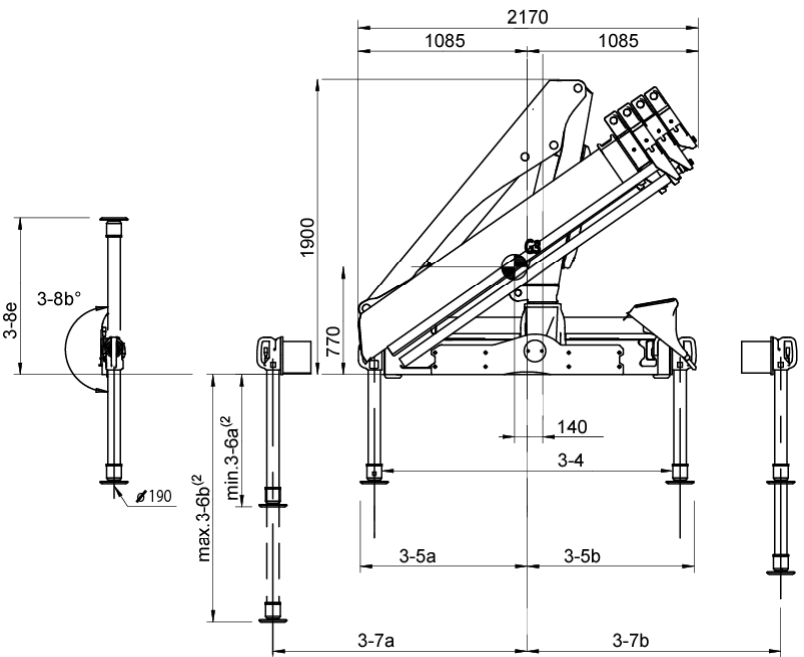

NOTE For specific values, see Table of Measurements

Top View Crane Base

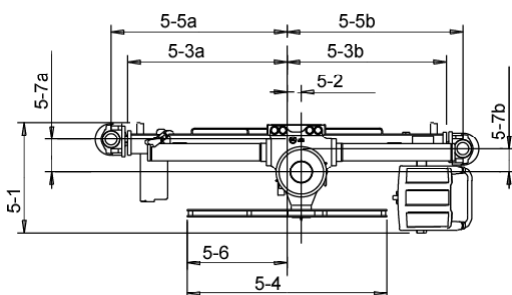

NOTE For specific values, see Table of Measurements

Chassis Installation

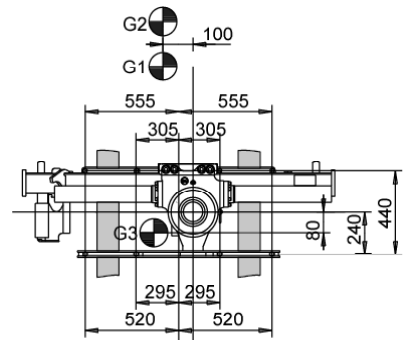

(1) Variable value depending on option.
 (2) Variations may occur depending on mounting position.

Load Diagram

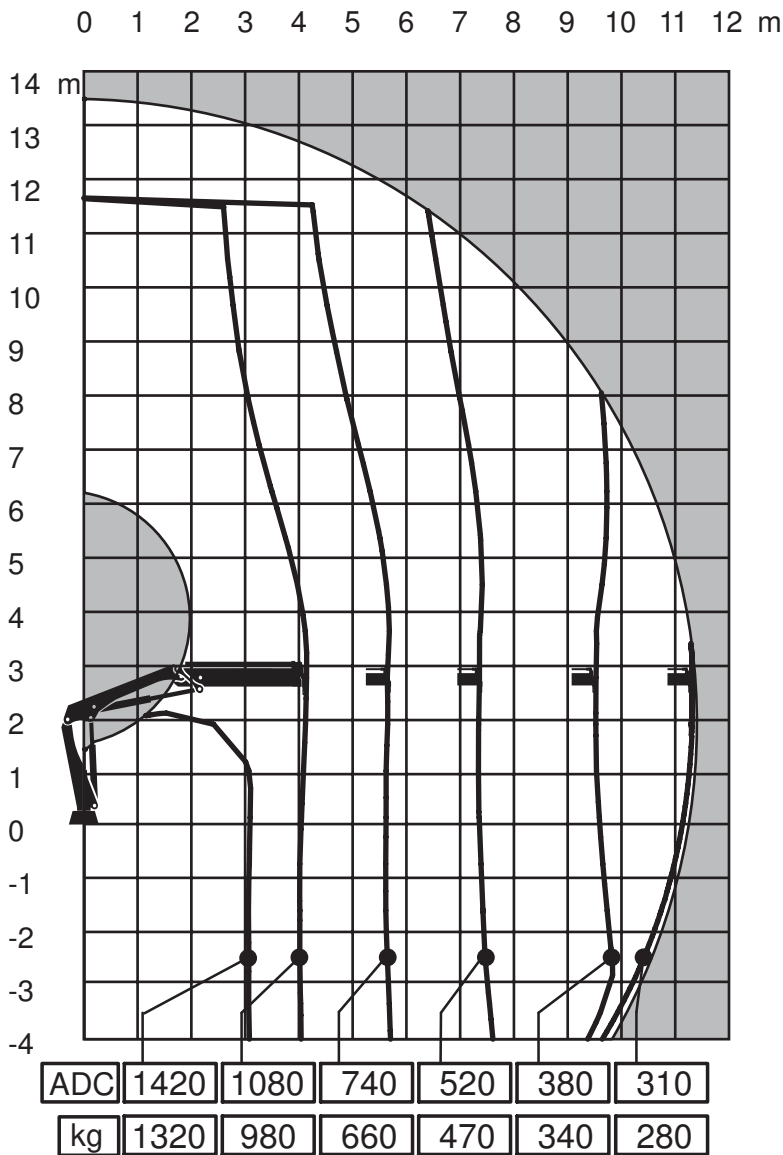

Side View Unfolded Close in Area

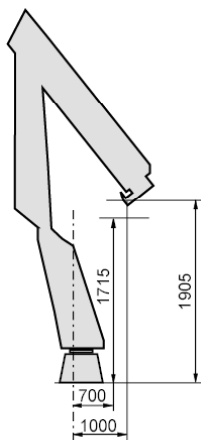

Capacity and performance

Lifting capacity with ADC	43	(kNm)
Lifting capacity	39	(kNm)
Standard lifting capacity at standard outreach with ADC	3.1	(m) - 1420 (kg)
	4.1	(m) - 1080 (kg)
	5.6	(m) - 740 (kg)
	7.4	(m) - 520 (kg)
	9.4	(m) - 380 (kg)
	11.3	(m) - 310 (kg)
Standard lifting capacity at standard outreach	3.1	(m) - 1320 (kg)
	4.1	(m) - 980 (kg)
	5.6	(m) - 660 (kg)
	7.4	(m) - 470 (kg)
	9.4	(m) - 340 (kg)
	11.3	(m) - 280 (kg)
Hydraulic boom extension	7.3	(m)
Lifting height above installation level hydraulic	13.5	(m)
Slewing torque	7.7	(kNm)
V80 Slewing speed	15	(°/s)
Slewing angle	410	(°)
Lifting speed	2.1	(m/s)

Functional demands

Recommended oilflow low	25	(l/min)
Recommended oilflow high	30	(l/min)
Working pressure	24	(MPa)
Max slope viable at full capacity	5	(°)
Oil in tank	65	(l)
Tank capacity	75	(l)

Weights and measurements

Height in folded position	1900	(mm)
Width in folded position	2170	(mm)
Installation space needed	650	(mm)
Weight of crane	950	(kg)
Weight control stations (platform & top seat)	30	(kg)

Side View Unfolded Stretched

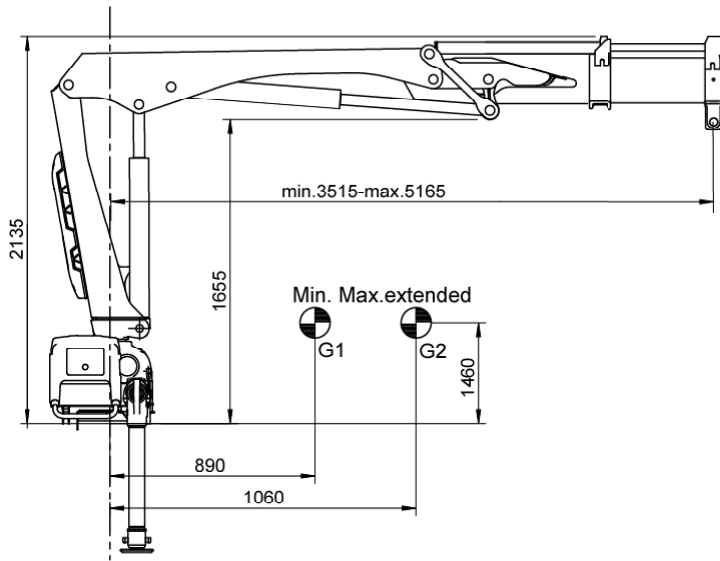

Side View Folded



Front View Folded

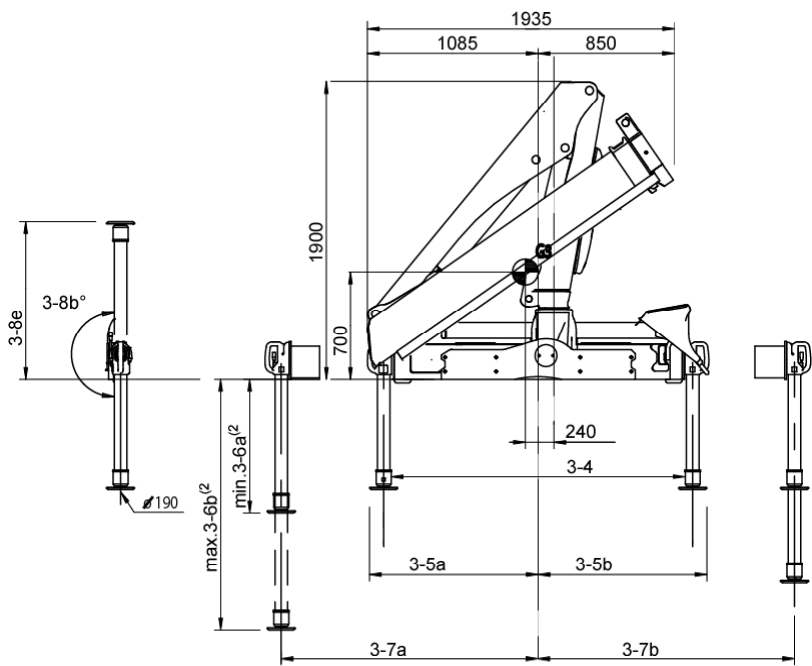

NOTE For specific values, see Table of Measurement

Top View Crane Base

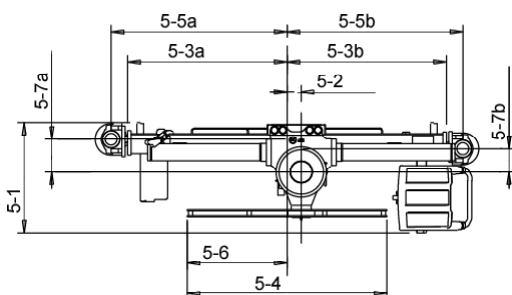

NOTE For specific values, see Table of Measurements

Chassis Installation

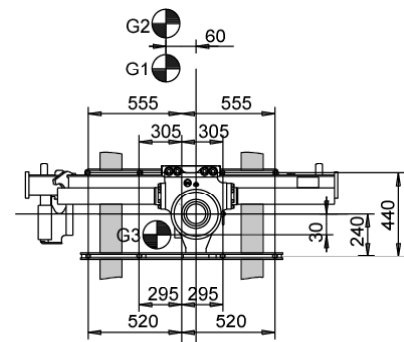

(1) Variable value depending on option.
 (2) Variations may occur depending on mounting position.

Load Diagram

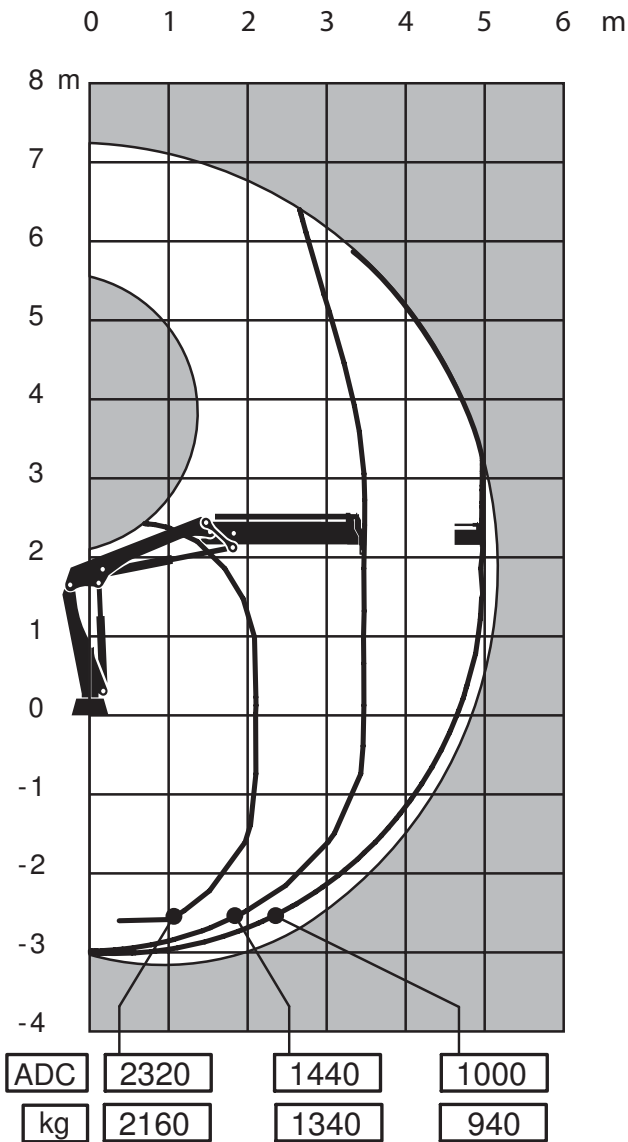

Side View Unfolded Close in Area

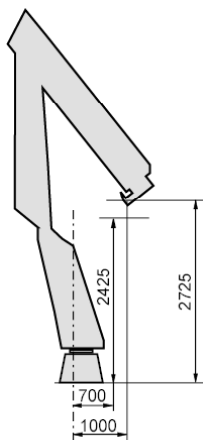

Capacity and performance

Lifting capacity with ADC	49	(kNm)
Lifting capacity	46	(kNm)
Standard lifting capacity at standard outreach with ADC	2.1 (m) - 2320 (kg)	
	3.5 (m) - 1440 (kg)	
	5.0 (m) - 1000 (kg)	
Standard lifting capacity at standard outreach	2.1 (m) - 2160 (kg)	
	3.5 (m) - 1340 (kg)	
	5.0 (m) - 940 (kg)	
Manual lifting capacity at extension	6.9 (m) - 700 (kg)	
	9.0 (m) - 500 (kg)	
Hydraulic boom extension	1.7	(m)
Lifting height above installation level hydraulic	7.2	(m)
Slewing torque	7.7	(kNm)
V80 Slewing speed	15	(°/s)
Slewing angle	410	(°)
Lifting speed	1.0	(m/s)

Functional demands

Recommended oilflow low	25	(l/min)
Recommended oilflow high	30	(l/min)
Working pressure	24	(MPa)
Max slope viable at full capacity	5	(°)
Oil in tank	35	(l)
Tank capacity	40	(l)

Weights and measurements

Height in folded position	1900	(mm)
Width in folded position	1935	(mm)
Installation space needed	650	(mm)
Weight of crane	740	(kg)
Weight control stations (platform & top seat)	30	(kg)
Weight hose- and pipe kit	30	(kg)

Side View Unfolded Stretched

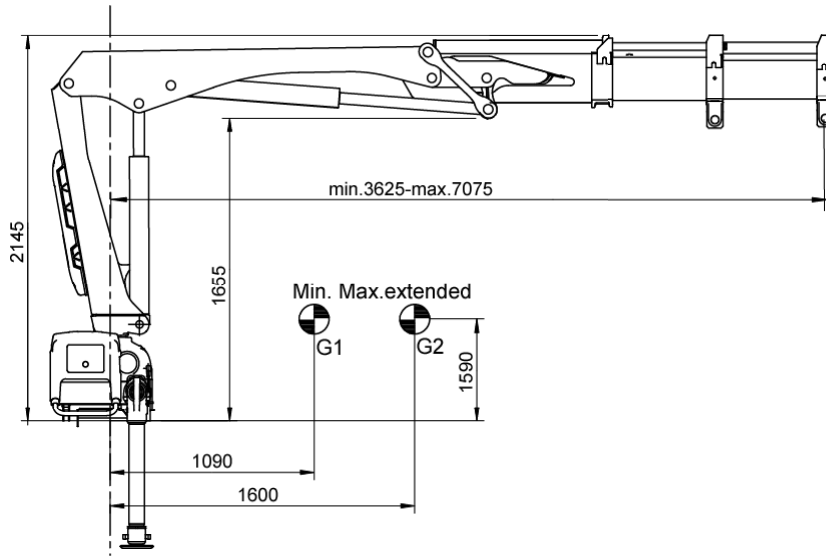

Side View Folded

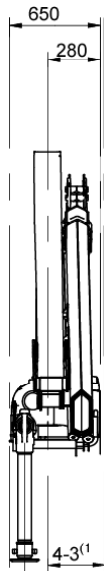

Front View Folded

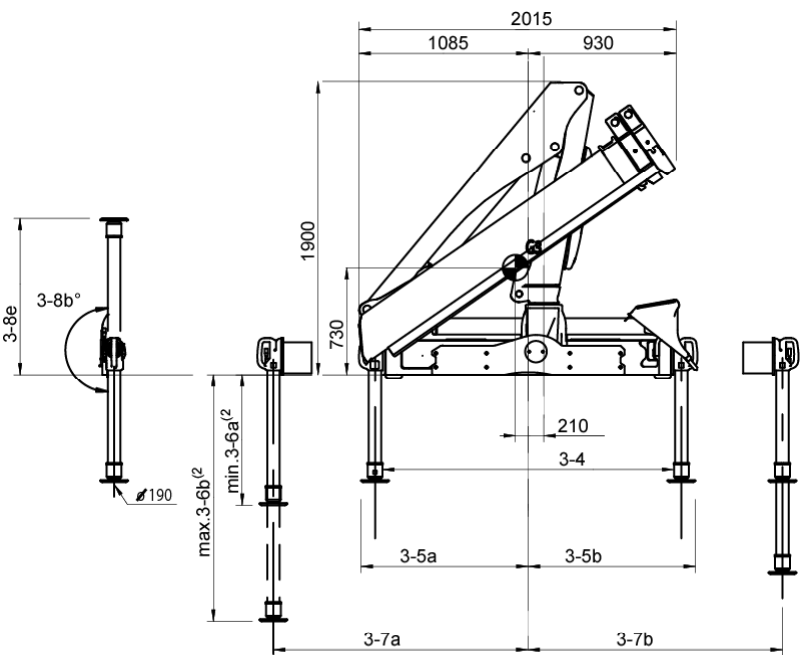

NOTE For specific values, see Table of Measurements

Top View Crane Base

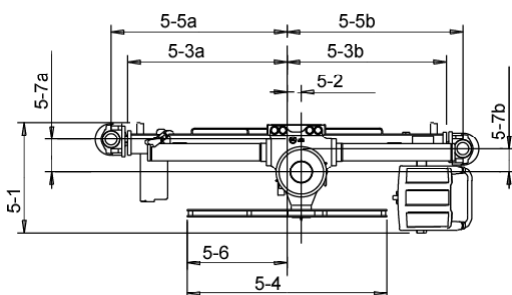

NOTE For specific values, see Table of Measurements

Chassis Installation

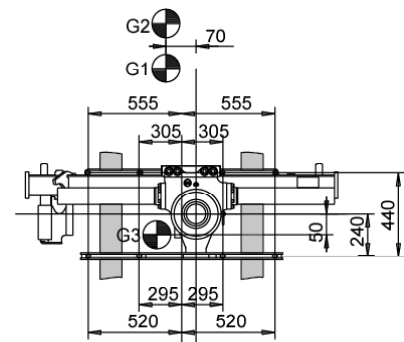

(1) Variable value depending on option.
 (2) Variations may occur depending on mounting position.

Load Diagram

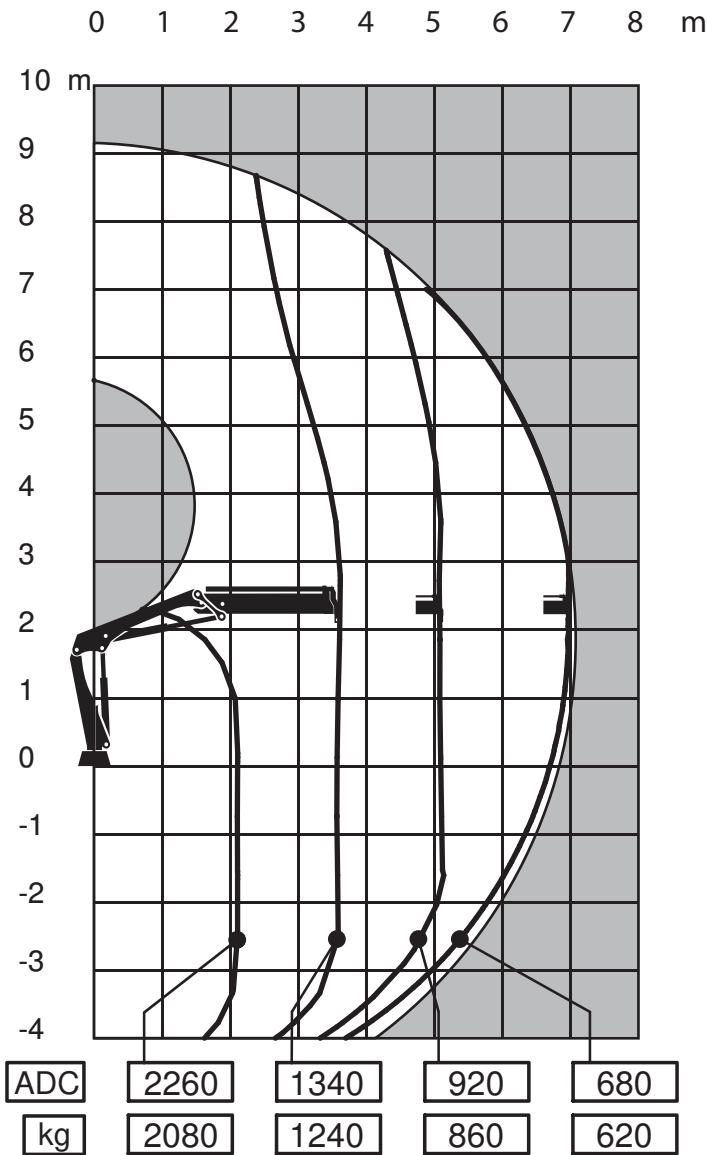

Side View Unfolded Close in Area

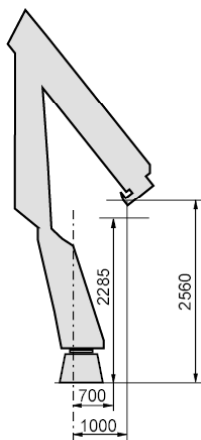

Capacity and performance

Lifting capacity with ADC	47	(kNm)
Lifting capacity	44	(kNm)
Standard lifting capacity at standard outreach with ADC	2.1 (m)	- 2260 (kg)
	3.6 (m)	- 1340 (kg)
	5.1 (m)	- 920 (kg)
	6.9 (m)	- 680 (kg)
Standard lifting capacity at standard outreach	2.1 (m)	- 2080 (kg)
	3.6 (m)	- 1240 (kg)
	5.1 (m)	- 860 (kg)
	6.9 (m)	- 620 (kg)
Manual lifting capacity at extension	9.0 (m)	- 480 (kg)
	11.0 (m)	- 310 (kg)
Hydraulic boom extension	3.5	(m)
Lifting height above installation level hydraulic	9.2	(m)
Slewing torque	7.7	(kNm)
V80 Slewing speed	15	(°/s)
Slewing angle	410	(°)
Lifting speed	1.3	(m/s)

Functional demands

Recommended oilflow low	25	(l/min)
Recommended oilflow high	30	(l/min)
Working pressure	24	(MPa)
Max slope viable at full capacity	5	(°)
Oil in tank	35	(l)
Tank capacity	40	(l)

Weights and measurements

Height in folded position	1900	(mm)
Width in folded position	2015	(mm)
Installation space needed	650	(mm)
Weight of crane	810	(kg)
Weight control stations (platform & top seat)	30	(kg)
Weight hose- and pipe kit	35	(kg)

Side View Unfolded Stretched

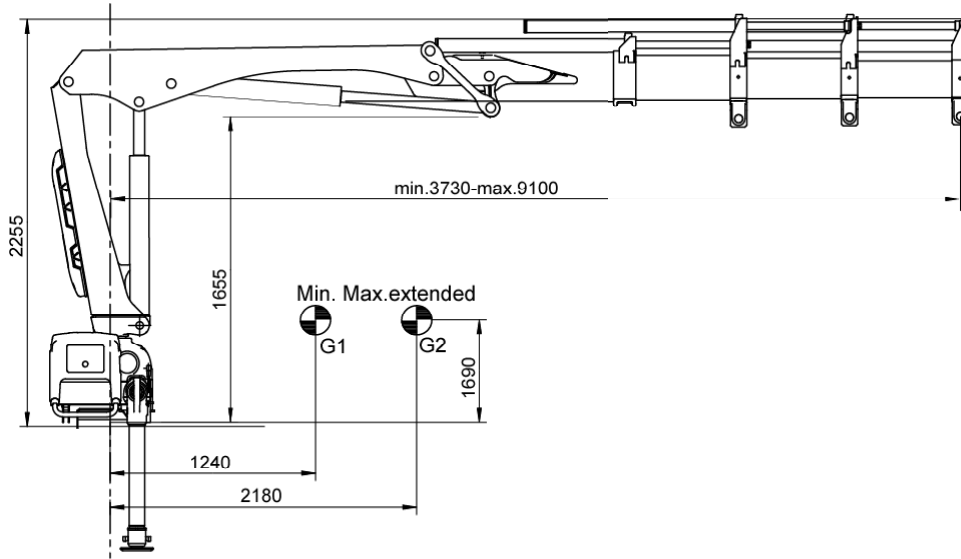

Side View Folded



Front View Folded

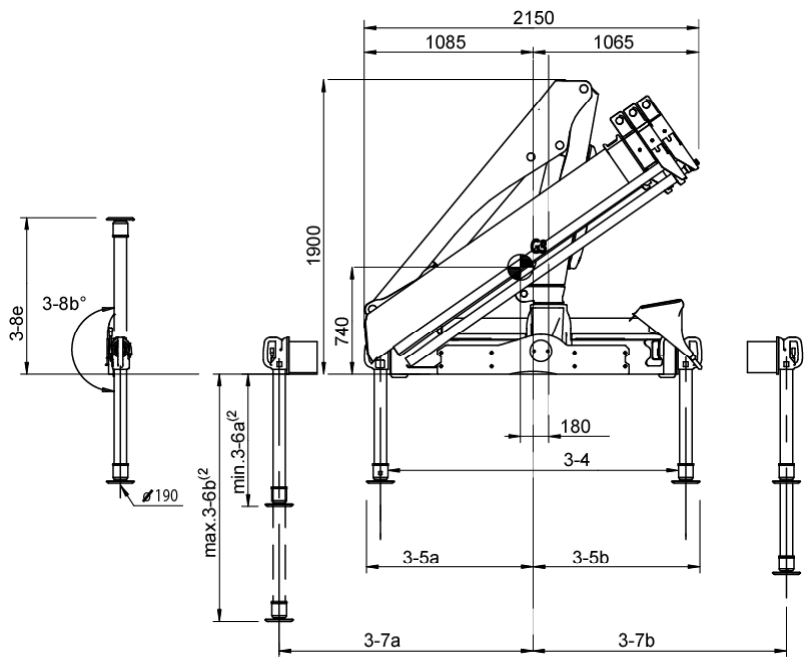

NOTE For specific values, see Table of Measurements

Top View Crane Base

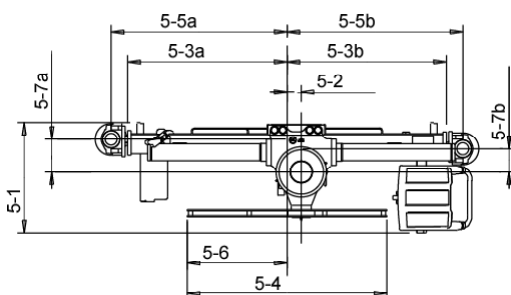

NOTE For specific values, see Table of Measurements

Chassis Installation

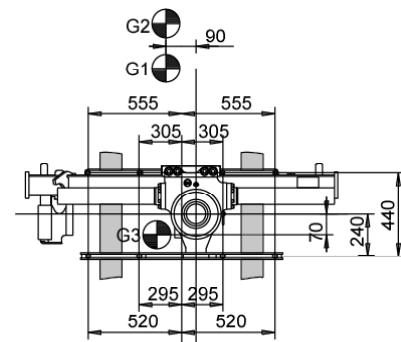

(1) Variable value depending on option.
 (2) Variations may occur depending on mounting position.

Load Diagram

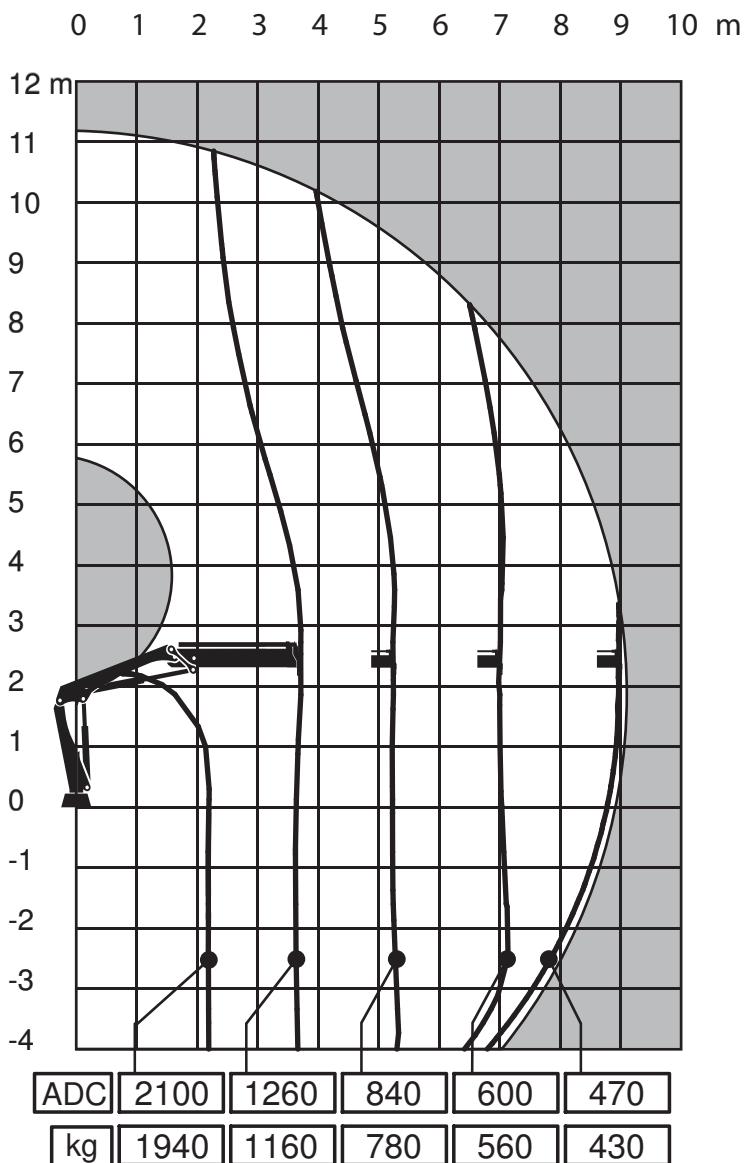

Side View Unfolded Close in Area

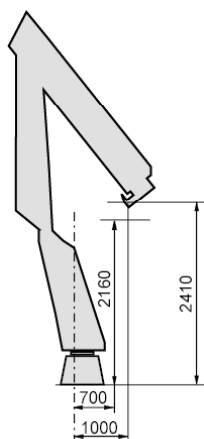

Capacity and performance

Lifting capacity with ADC	46	(kNm)
Lifting capacity	42	(kNm)
Standard lifting capacity at standard outreach with ADC	2.2 (m) - 2100 (kg)	
	3.7 (m) - 1260 (kg)	
	5.3 (m) - 840 (kg)	
	7.1 (m) - 600 (kg)	
	9.0 (m) - 470 (kg)	
Standard lifting capacity at standard outreach	2.2 (m) - 1940 (kg)	
	3.7 (m) - 1160 (kg)	
	5.3 (m) - 780 (kg)	
	7.1 (m) - 560 (kg)	
	9.0 (m) - 430 (kg)	
Manual lifting capacity at extension	11.0 (m) - 330 (kg)	
Hydraulic boom extension	5.4	(m)
Lifting height above installation level hydraulic	11.2	(m)
Slewing torque	7.7	(kNm)
V80 Slewing speed	15	(°/s)
Slewing angle	410	(°)
Lifting speed	1.7	(m/s)

Functional demands

Recommended oilflow low	25	(l/min)
Recommended oilflow high	30	(l/min)
Working pressure	24	(MPa)
Max slope viable at full capacity	5	(°)
Oil in tank	65	(l)
Tank capacity	75	(l)

Weights and measurements

Height in folded position	1900	(mm)
Width in folded position	2150	(mm)
Installation space needed	650	(mm)
Weight of crane	880	(kg)
Weight control stations (platform & top seat)	30	(kg)

Side View Unfolded Stretched

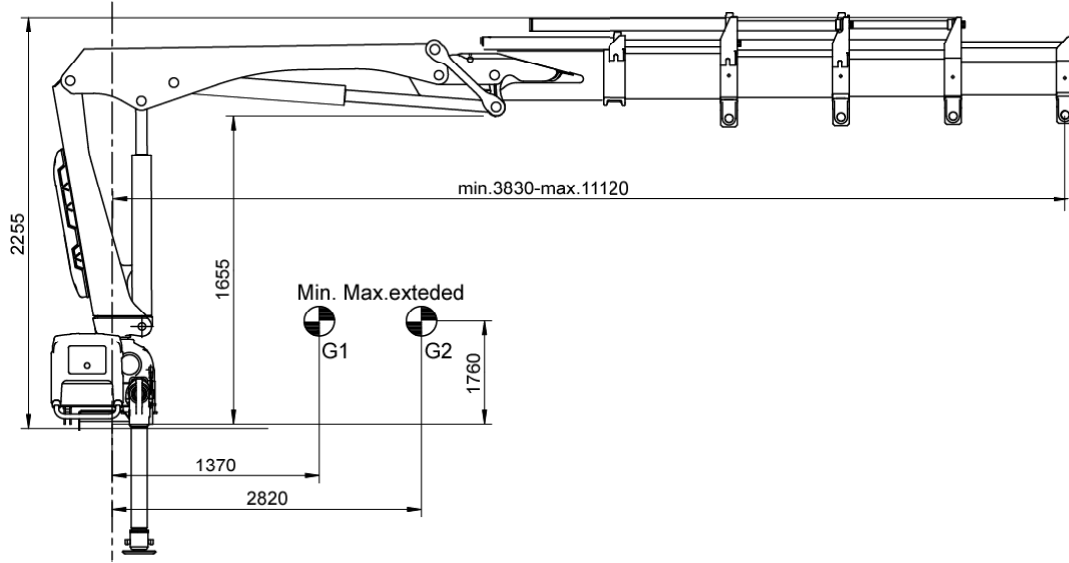

Side View Folded



Front View Folded

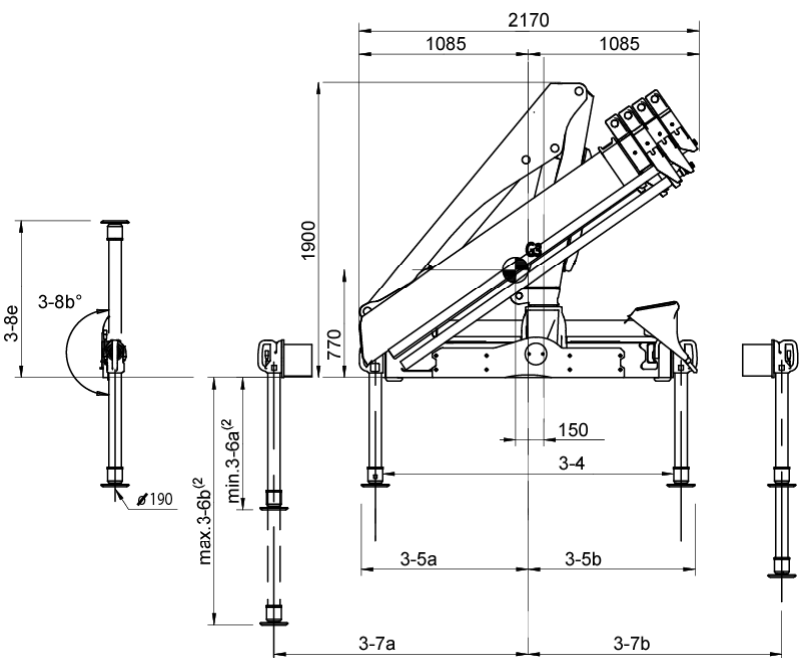

NOTE For specific values, see Table of Measurements

Top View Crane Base

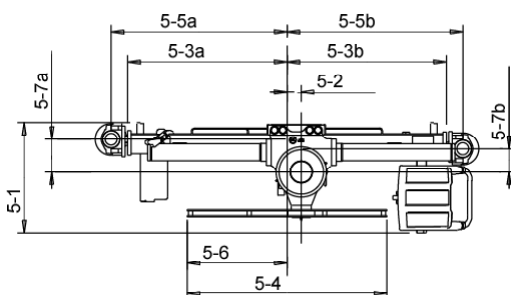

NOTE For specific values, see Table of Measurements

Chassis Installation

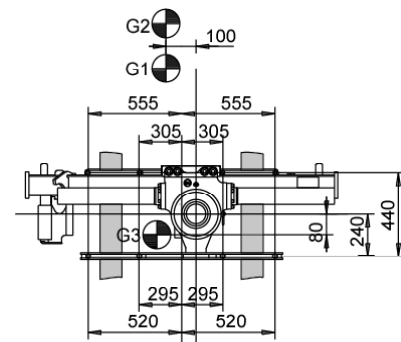

(1) Variable value depending on option.
 (2) Variations may occur depending on mounting position.

Load Diagram

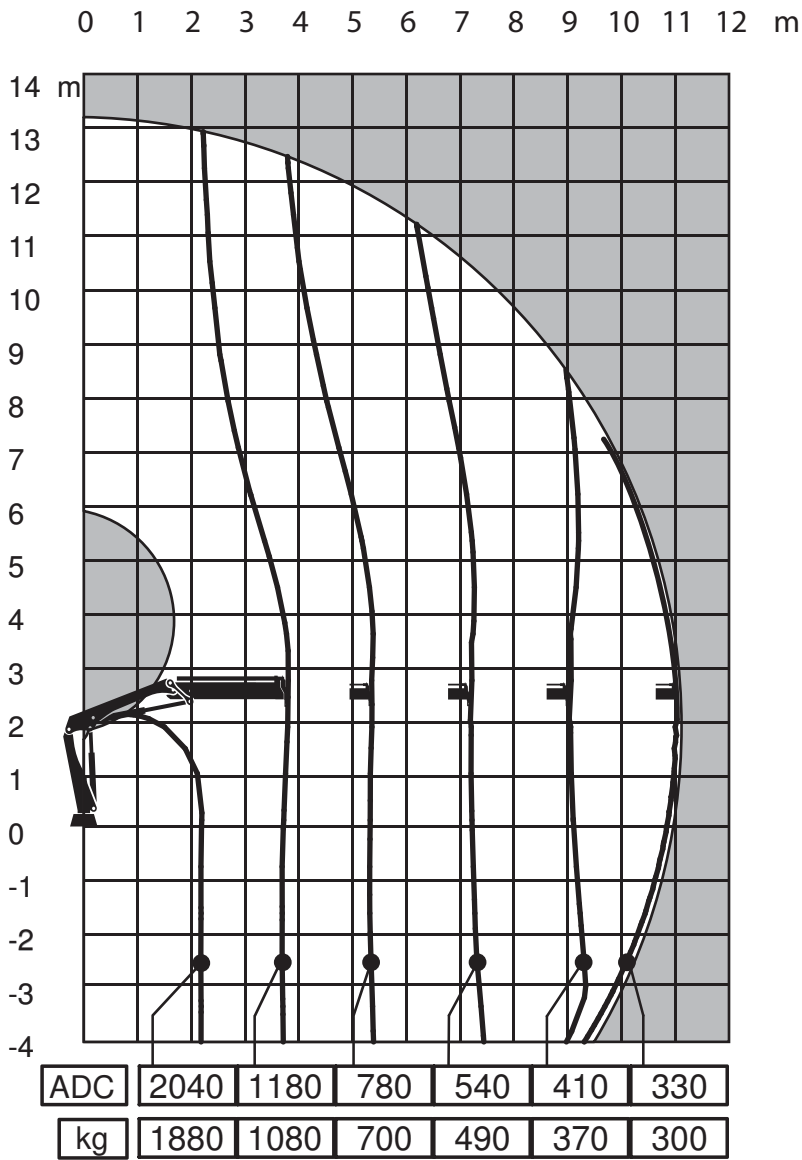

Side View Unfolded Close in Area

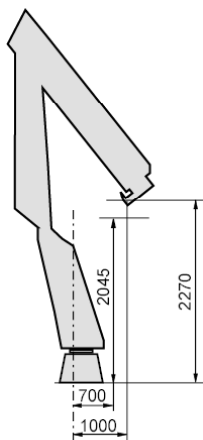

Capacity and performance

Lifting capacity with ADC	44	(kNm)
Lifting capacity	40	(kNm)
Standard lifting capacity at standard outreach with ADC	2.2 (m)	- 2040 (kg)
	3.8 (m)	- 1180 (kg)
	5.4 (m)	- 780 (kg)
	7.2 (m)	- 540 (kg)
	9.1 (m)	- 410 (kg)
Standard lifting capacity at standard outreach	11.0 (m)	- 330 (kg)
	2.2 (m)	- 1880 (kg)
	3.8 (m)	- 1080 (kg)
	5.4 (m)	- 700 (kg)
	7.2 (m)	- 490 (kg)
	9.1 (m)	- 370 (kg)
	11.0 (m)	- 300 (kg)
Hydraulic boom extension	7.3	(m)
Lifting height above installation level hydraulic	13.2	(m)
Slewing torque	7.7	(kNm)
V80 Slewing speed	15	(°/s)
Slewing angle	410	(°)
Lifting speed	2.0	(m/s)

Functional demands

Recommended oilflow low	25	(l/min)
Recommended oilflow high	30	(l/min)
Working pressure	24	(MPa)
Max slope viable at full capacity	5	(°)
Oil in tank	65	(l)
Tank capacity	75	(l)

Weights and measurements

Height in folded position	1900	(mm)
Width in folded position	2170	(mm)
Installation space needed	650	(mm)
Weight of crane	940	(kg)
Weight control stations (platform & top seat)	30	(kg)

Side View Unfolded Stretched

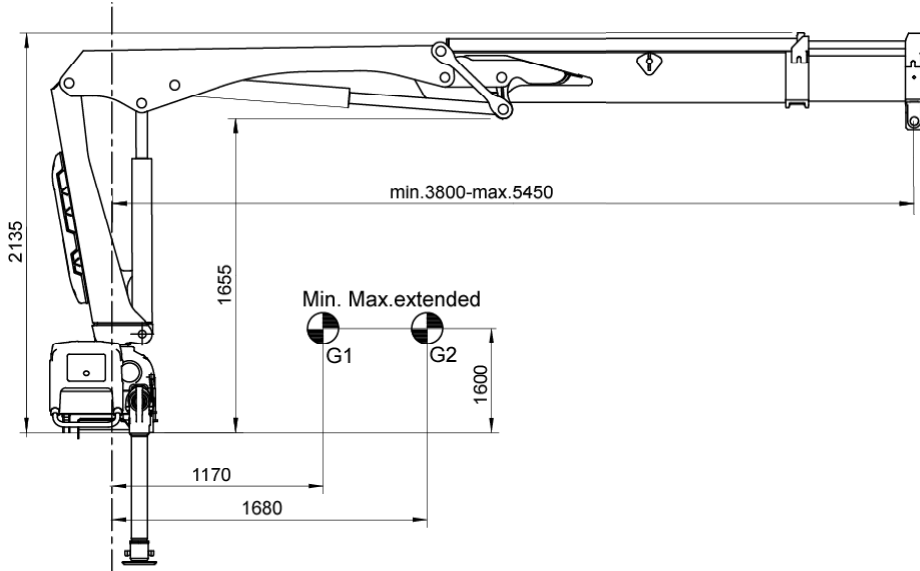

Side View Folded



Front View Folded

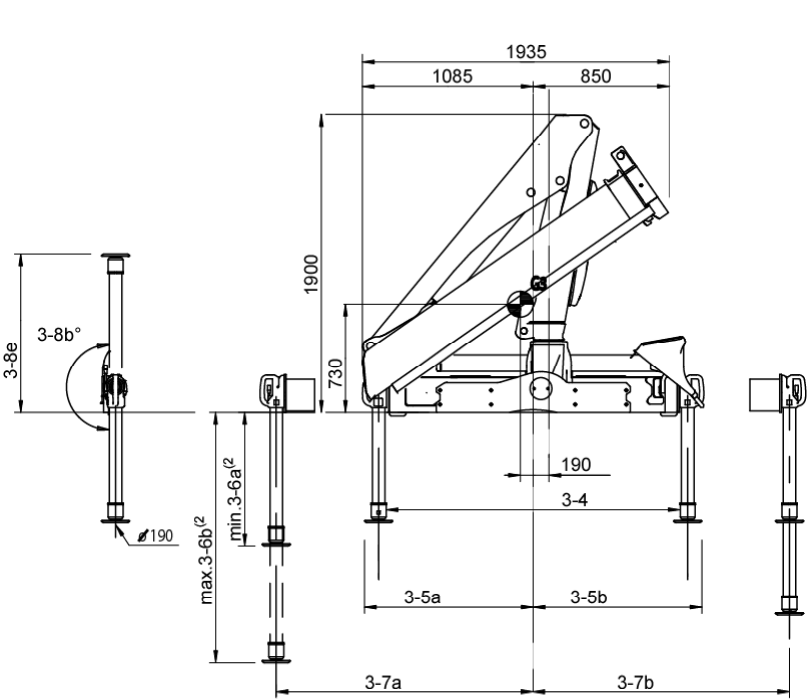

NOTE For specific values, see Table of Measurements

Top View Crane Base

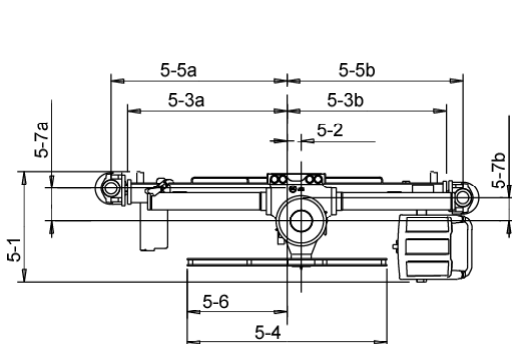

NOTE For specific values, see Table of Measurements

Chassis Installation

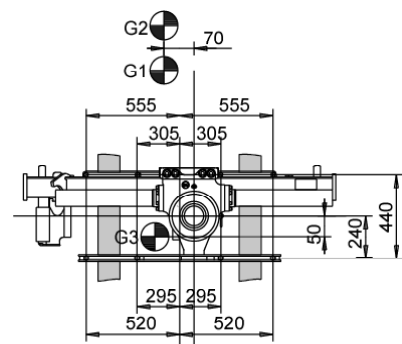

(1) Variable value depending on option.
 (2) Variations may occur depending on mounting position.

Load Diagram

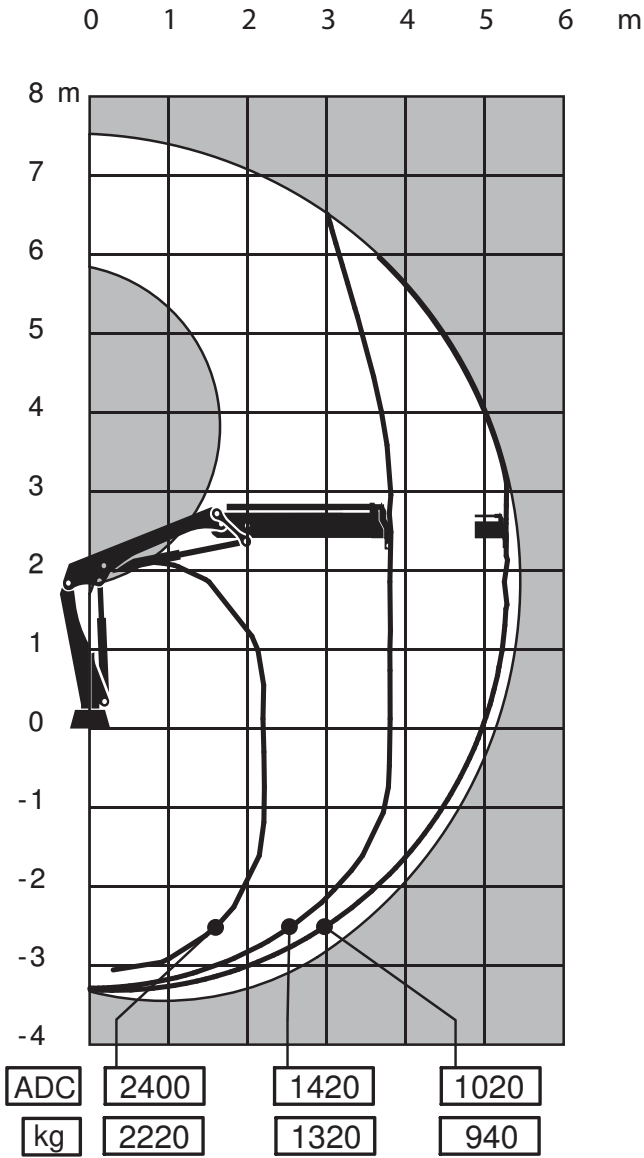

Side View Unfolded Close in Area

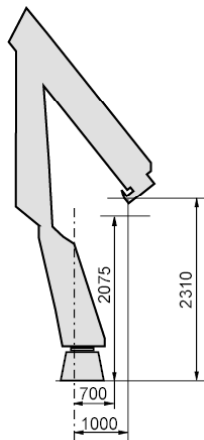

Capacity and performance

Lifting capacity with ADC	53	(kNm)
Lifting capacity	49	(kNm)
Standard lifting capacity at standard outreach with ADC	2.2 (m) - 2400 (kg)	
	3.8 (m) - 1420 (kg)	
	5.3 (m) - 1020 (kg)	
Standard lifting capacity at standard outreach	2.2 (m) - 2220 (kg)	
	3.8 (m) - 1320 (kg)	
	5.3 (m) - 940 (kg)	
Manual lifting capacity at extension	7.2 (m) - 720 (kg)	
	9.3 (m) - 520 (kg)	
Hydraulic boom extension	1.7	(m)
Lifting height above installation level hydraulic	7.5	(m)
Slewing torque	7.7	(kNm)
V80 Slewing speed	15	(°/s)
Slewing angle	410	(°)
Lifting speed	1.0	(m/s)

Functional demands

Recommended oilflow low	30	(l/min)
Recommended oilflow high	40	(l/min)
Working pressure	26	(MPa)
Max slope viable at full capacity	5	(°)
Oil in tank	65	(l)
Tank capacity	75	(l)

Weights and measurements

Height in folded position	1900	(mm)
Width in folded position	1935	(mm)
Installation space needed	650	(mm)
Weight of crane	740	(kg)
Weight control stations (platform & top seat)	30	(kg)
Weight hose- and pipe kit	30	(kg)

Side View Unfolded Stretched

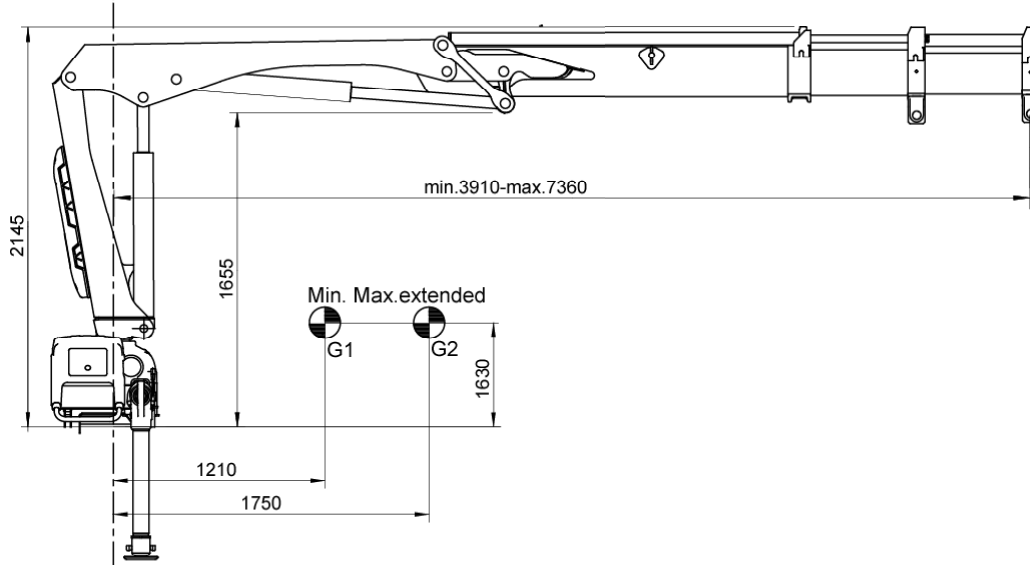

Side View Folded



Front View Folded

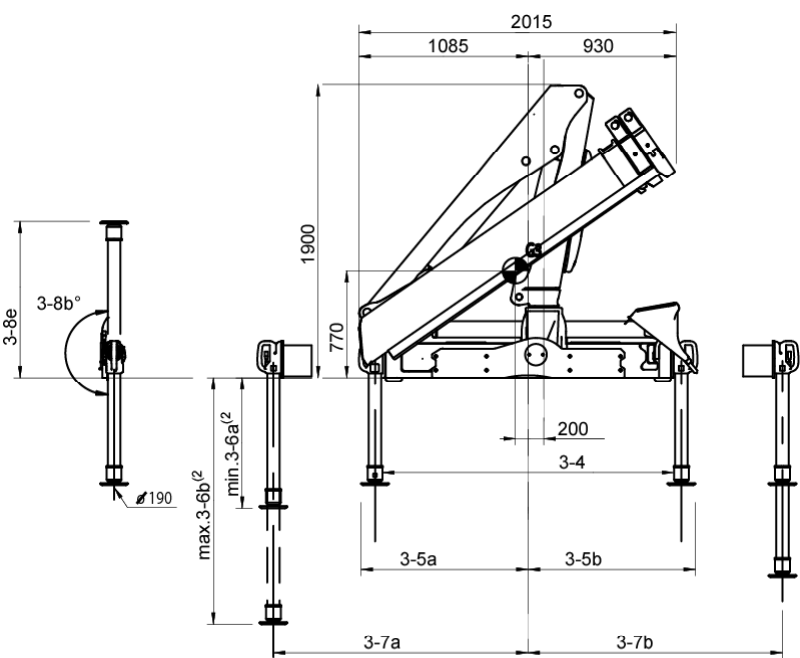

NOTE For specific values, see Table of Measurements

Top View Crane Base

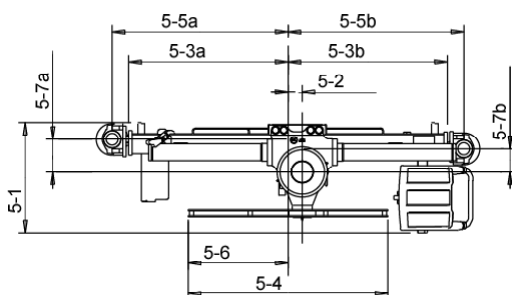

NOTE For specific values, see Table of Measurements

Chassis Installation

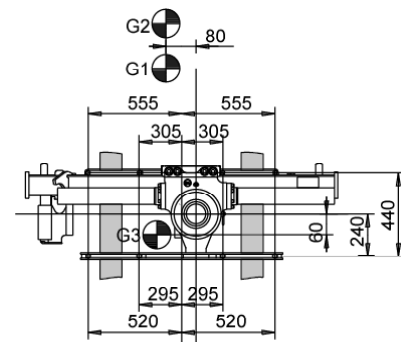

(1) Variable value depending on option.
 (2) Variations may occur depending on mounting position.

Load Diagram

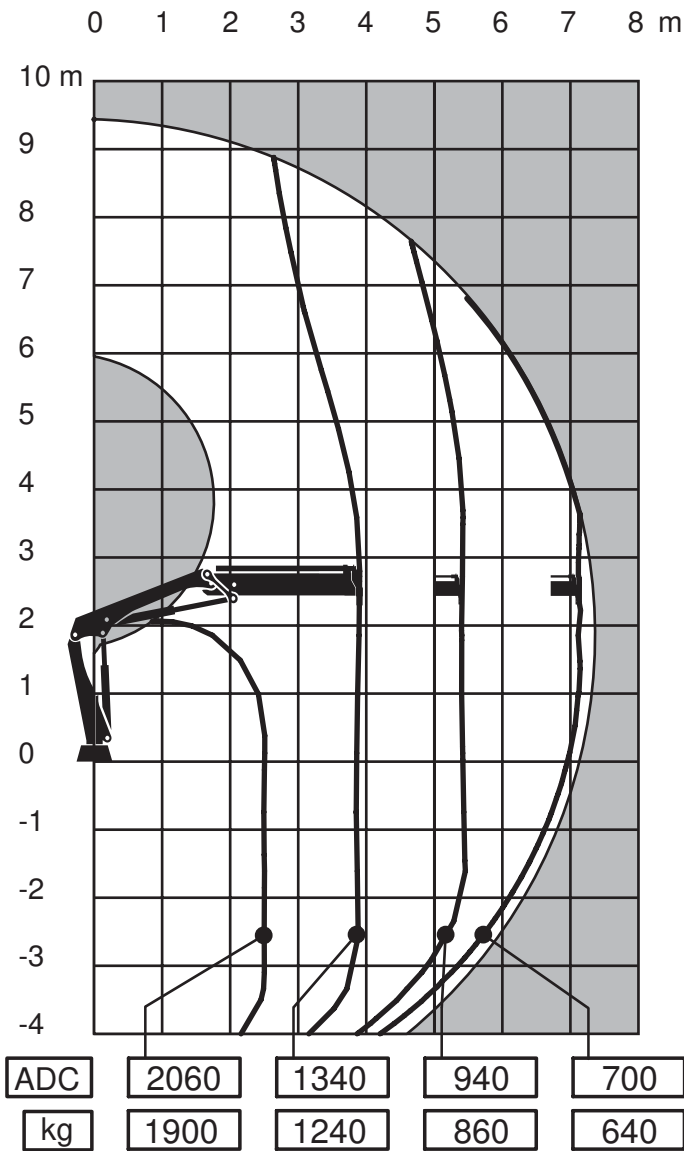

Side View Unfolded Close in Area

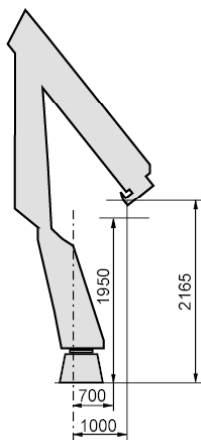

Capacity and performance

Lifting capacity with ADC	51	(kNm)
Lifting capacity	47	(kNm)
Standard lifting capacity at standard outreach with ADC	2.5	(m) - 2060 (kg)
	3.9	(m) - 1340 (kg)
	5.4	(m) - 940 (kg)
Standard lifting capacity at standard outreach	7.2	(m) - 700 (kg)
	2.5	(m) - 1900 (kg)
	3.9	(m) - 1240 (kg)
Manual lifting capacity at extension	5.4	(m) - 860 (kg)
	7.2	(m) - 640 (kg)
Hydraulic boom extension	9.3	(m) - 500 (kg)
Lifting height above installation level hydraulic	11.2	(m) - 390 (kg)
Slewing torque	3.5	(m)
V80 Slewing speed	9.4	(m)
Slewing angle	7.7	(kNm)
Lifting speed	15	(°/s)
Functional demands	410	(°)
Recommended oilflow low	1.3	(m/s)
Recommended oilflow high	30	(l/min)
Working pressure	40	(l/min)
Max slope viable at full capacity	26	(MPa)
Oil in tank	5	(°)
Tank capacity	65	(l)
Weights and measurements	75	(l)
Height in folded position	1900	(mm)
Width in folded position	2015	(mm)
Installation space needed	650	(mm)
Weight of crane	820	(kg)
Weight control stations (platform & top seat)	30	(kg)
Weight hose- and pipe kit	35	(kg)

Functional demands

Recommended oilflow low	30	(l/min)
Recommended oilflow high	40	(l/min)
Working pressure	26	(MPa)
Max slope viable at full capacity	5	(°)
Oil in tank	65	(l)
Tank capacity	75	(l)

Weights and measurements

Height in folded position	1900	(mm)
Width in folded position	2015	(mm)
Installation space needed	650	(mm)
Weight of crane	820	(kg)
Weight control stations (platform & top seat)	30	(kg)
Weight hose- and pipe kit	35	(kg)

Side View Unfolded Stretched

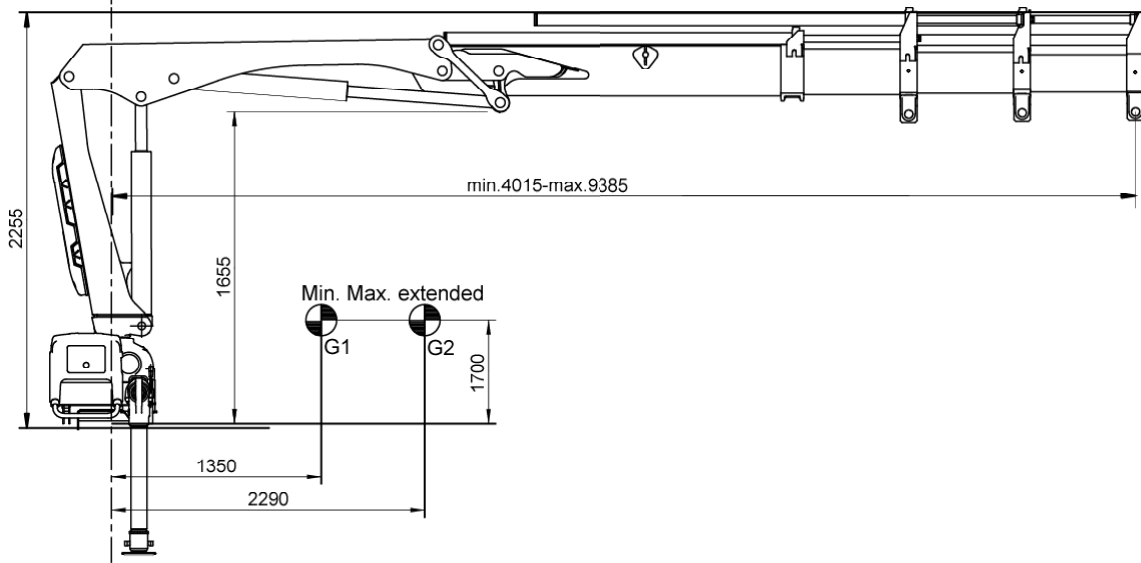

Side View Folded



Front View Folded

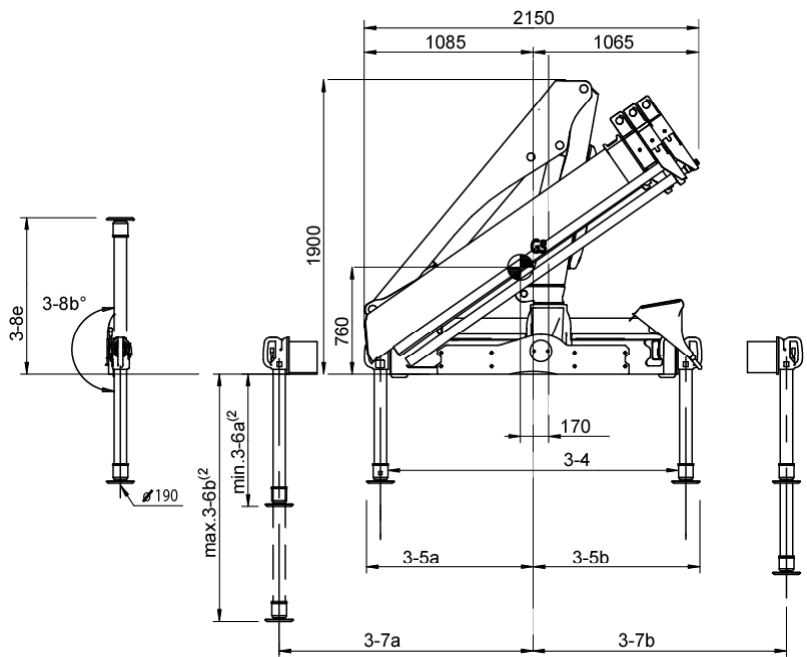

NOTE For specific values, see Table of Measurements

Top View Crane Base

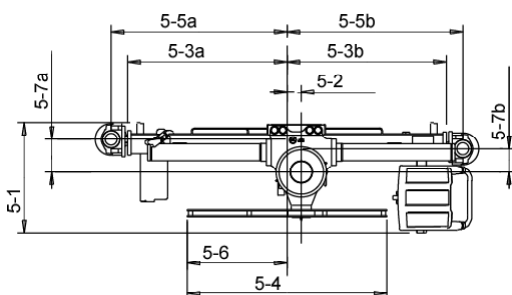

NOTE For specific values, see Table of Measurements

Chassis Installation

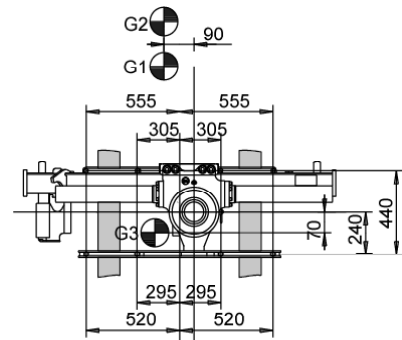

(1) Variable value depending on option.
 (2) Variations may occur depending on mounting position.

Load Diagram

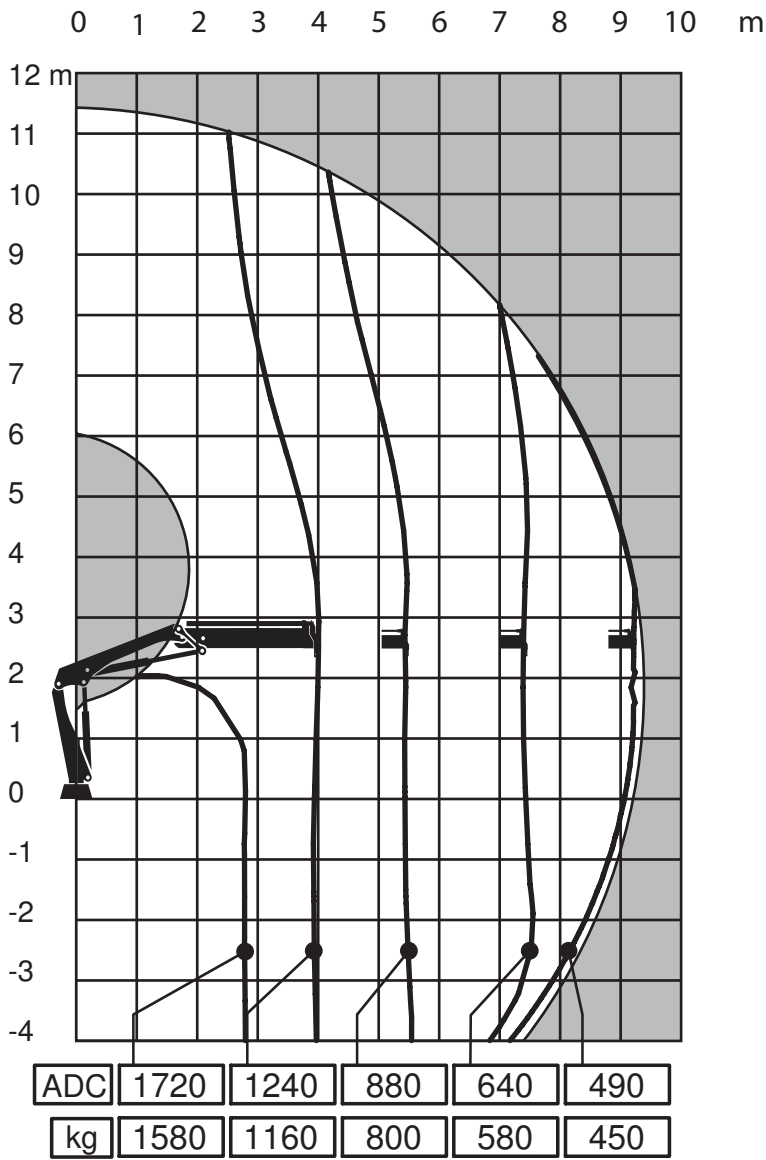

Side View Unfolded Close in Area

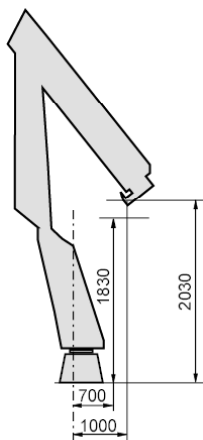

Capacity and performance

Lifting capacity with ADC	49	(kNm)
Lifting capacity	46	(kNm)
Standard lifting capacity at standard outreach with ADC	2.9	(m) - 1720 (kg)
	4.0	(m) - 1240 (kg)
	5.5	(m) - 880 (kg)
	7.3	(m) - 640 (kg)
	9.3	(m) - 490 (kg)
Standard lifting capacity at standard outreach	2.9	(m) - 1580 (kg)
	4.0	(m) - 1160 (kg)
	5.5	(m) - 800 (kg)
	7.3	(m) - 580 (kg)
	9.3	(m) - 450 (kg)
Manual lifting capacity at extension	11.2	(m) - 370 (kg)
Hydraulic boom extension	5.4	(m)
Lifting height above installation level hydraulic	11.5	(m)
Slewing torque	7.7	(kNm)
V80 Slewing speed	15	(°/s)
Slewing angle	410	(°)
Lifting speed	1.7	(m/s)

Functional demands

Recommended oilflow low	30	(l/min)
Recommended oilflow high	40	(l/min)
Working pressure	26	(MPa)
Max slope viable at full capacity	5	(°)
Oil in tank	65	(l)
Tank capacity	75	(l)

Weights and measurements

Height in folded position	1900	(mm)
Width in folded position	2150	(mm)
Installation space needed	650	(mm)
Weight of crane	880	(kg)
Weight control stations (platform & top seat)	30	(kg)

Side View Unfolded Stretched

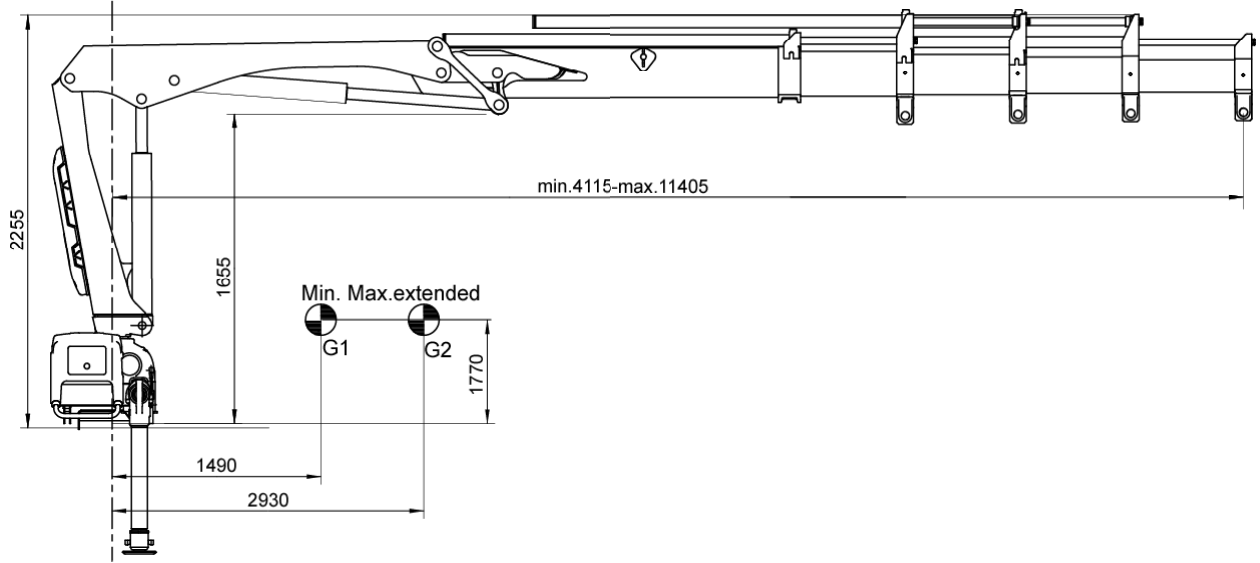

Side View Folded



Front View Folded

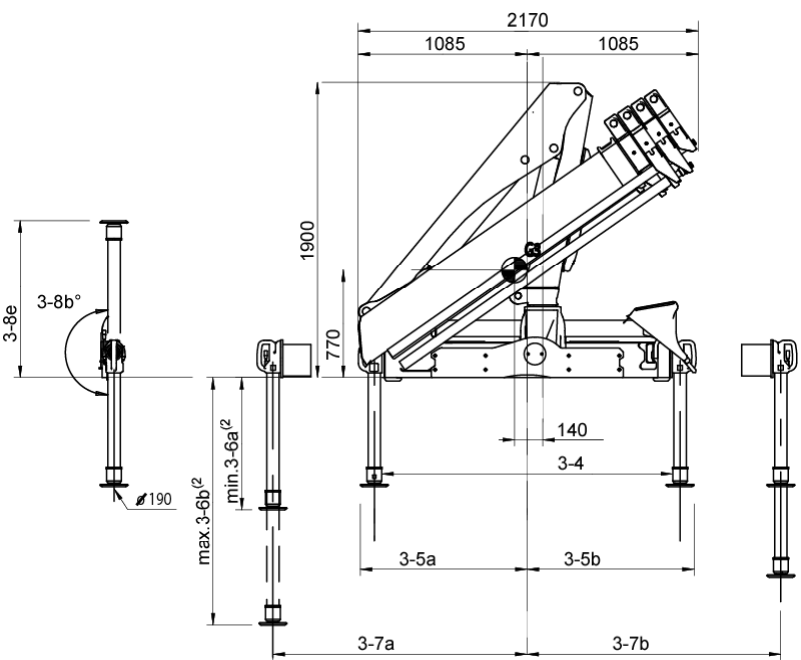

NOTE For specific values, see Table of Measurements

Top View Crane Base

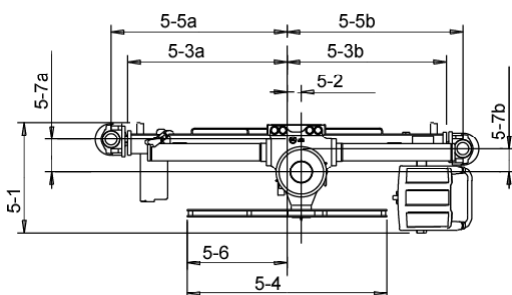

NOTE For specific values, see Table of Measurements

Chassis Installation

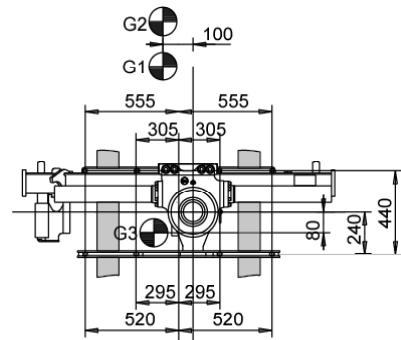

(1) Variable value depending on option.
 (2) Variations may occur depending on mounting position.

Load Diagram

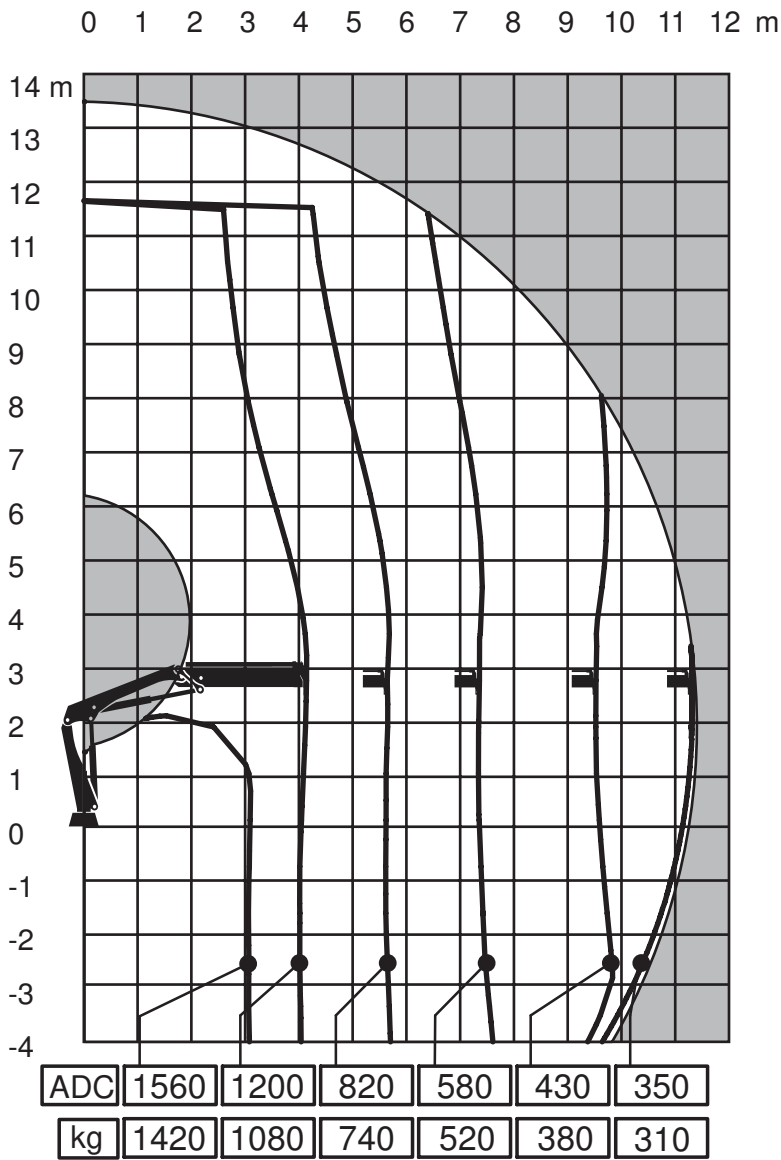

Side View Unfolded Close in Area

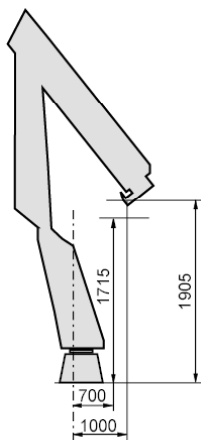

Capacity and performance

Lifting capacity with ADC	47	(kNm)
Lifting capacity	43	(kNm)
Standard lifting capacity at standard outreach with ADC	3.1 (m)	- 1560 (kg)
	4.1 (m)	- 1200 (kg)
	5.6 (m)	- 820 (kg)
	7.3 (m)	- 580 (kg)
	9.3 (m)	- 430 (kg)
	11.2 (m)	- 350 (kg)
Standard lifting capacity at standard outreach	3.1 (m)	- 1420 (kg)
	4.1 (m)	- 1080 (kg)
	5.6 (m)	- 740 (kg)
	7.3 (m)	- 520 (kg)
	9.3 (m)	- 380 (kg)
	11.2 (m)	- 310 (kg)
Hydraulic boom extension	7.3	(m)
Lifting height above installation level hydraulic	13.5	(m)
Slewing torque	7.7	(kNm)
V80 Slewing speed	15	(°/s)
Slewing angle	410	(°)
Lifting speed	2.1	(m/s)

Functional demands

Recommended oilflow low	30	(l/min)
Recommended oilflow high	40	(l/min)
Working pressure	26	(MPa)
Max slope viable at full capacity	5	(°)
Oil in tank	65	(l)
Tank capacity	75	(l)

Weights and measurements

Height in folded position	1900	(mm)
Width in folded position	2170	(mm)
Installation space needed	650	(mm)
Weight of crane	950	(kg)
Weight control stations (platform & top seat)	30	(kg)

Side View Unfolded Stretched

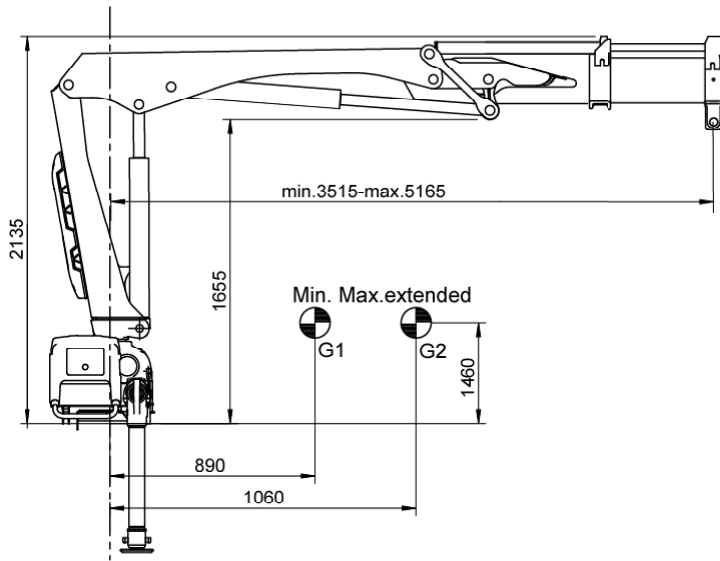

Side View Folded



Front View Folded

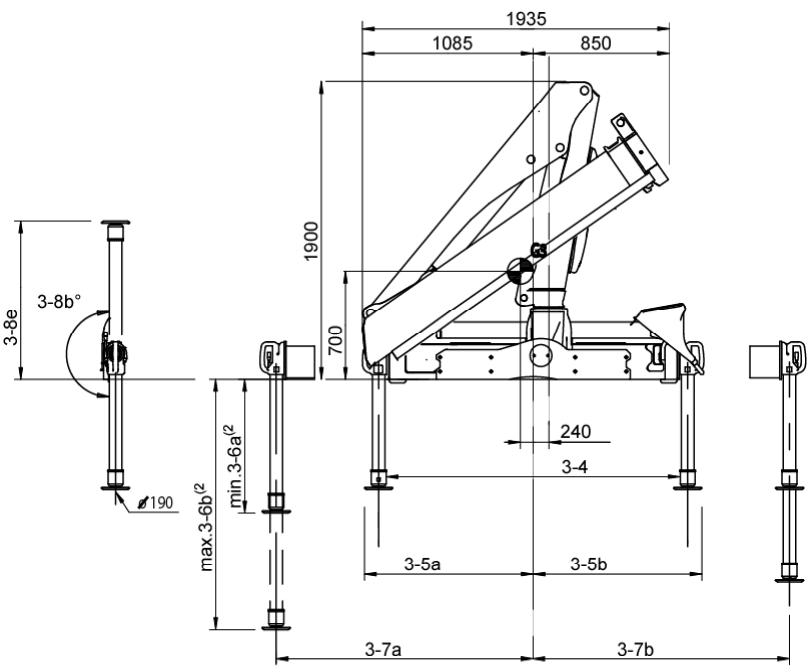

NOTE For specific values, see Table of Measurements

Top View Crane Base

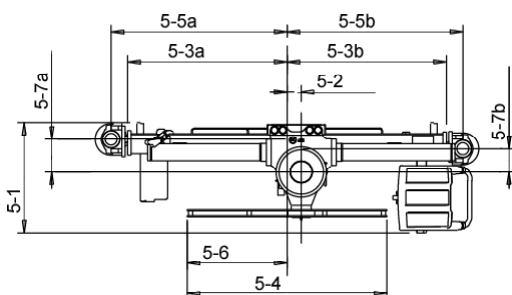

NOTE For specific values, see Table of Measurements

Chassis Installation

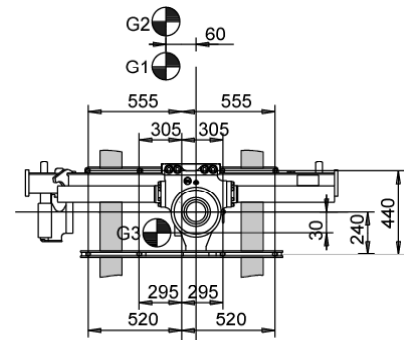

(1) Variable value depending on option.
 (2) Variations may occur depending on mounting position.

Load Diagram

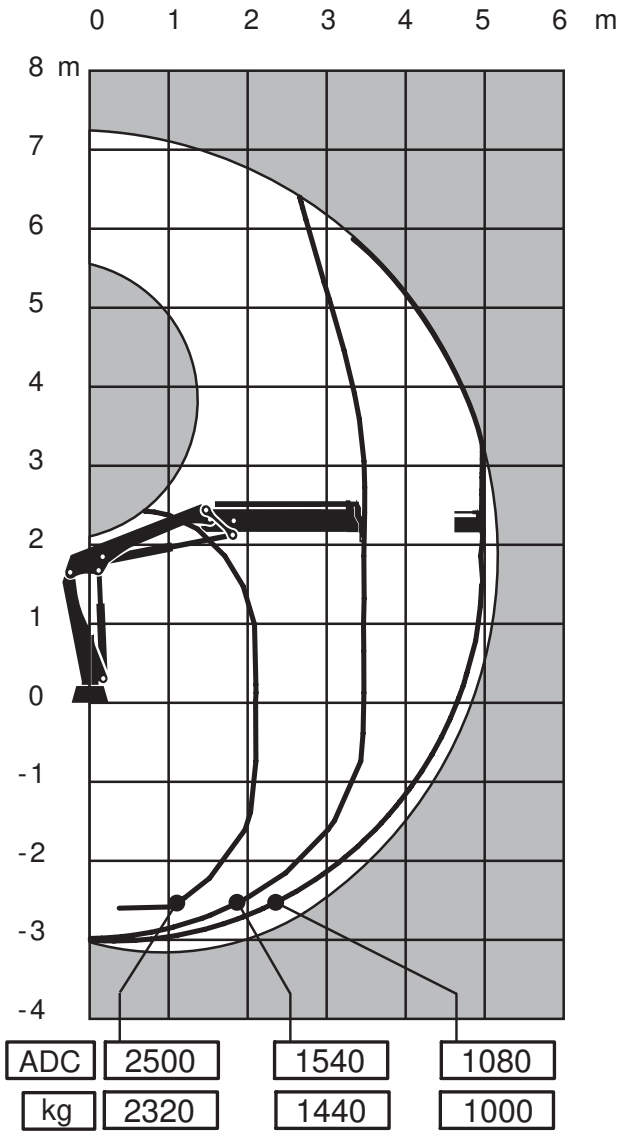

Capacity and performance

Lifting capacity with ADC	53	(kNm)
Lifting capacity	49	(kNm)
Standard lifting capacity at standard outreach with ADC	2.1 (m) - 2500 (kg)	
	3.5 (m) - 1540 (kg)	
	5.0 (m) - 1080 (kg)	
Standard lifting capacity at standard outreach	2.1 (m) - 2320 (kg)	
	3.5 (m) - 1440 (kg)	
	5.0 (m) - 1000 (kg)	
Manual lifting capacity at extension	6.9 (m) - 760 (kg)	
	9.0 (m) - 540 (kg)	
Hydraulic boom extension	1.7	(m)
Lifting height above installation level hydraulic	7.2	(m)
Slewing torque	7.7	(kNm)
V80 Slewing speed	15	(°/s)
Slewing angle	410	(°)
Lifting speed	1.0	(m/s)

Functional demands

Recommended oilflow low	30	(l/min)
Recommended oilflow high	40	(l/min)
Working pressure	26	(MPa)
Max slope viable at full capacity	5	(°)
Oil in tank	65	(l)
Tank capacity	75	(l)

Weights and measurements

Height in folded position	1900	(mm)
Width in folded position	1935	(mm)
Installation space needed	650	(mm)
Weight of crane	740	(kg)
Weight control stations (platform & top seat)	30	(kg)
Weight hose- and pipe kit	30	(kg)

Side View Unfolded Close in Area

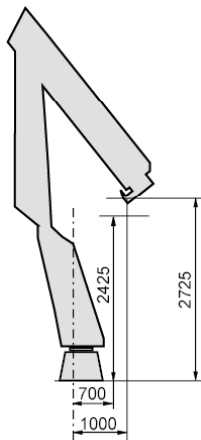

Side View Unfolded Stretched

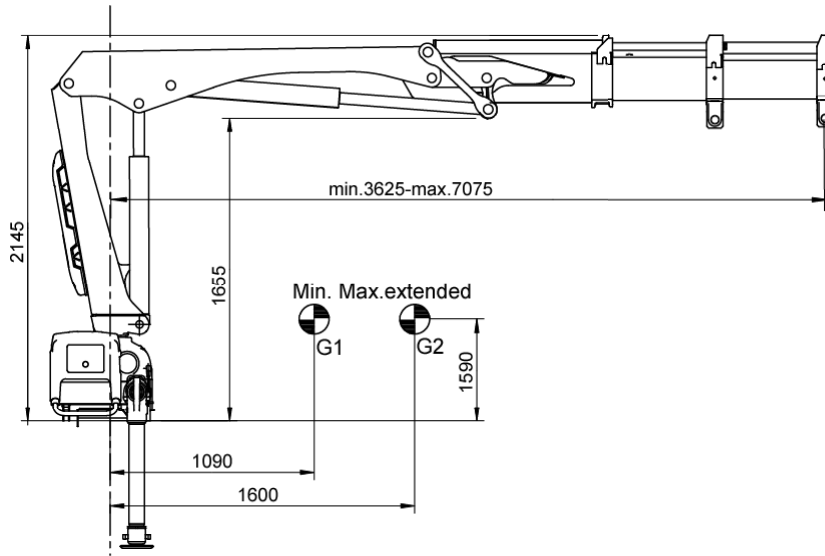

Side View Folded

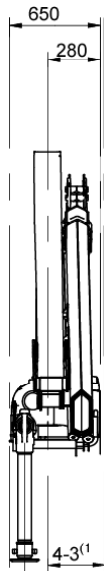

Front View Folded

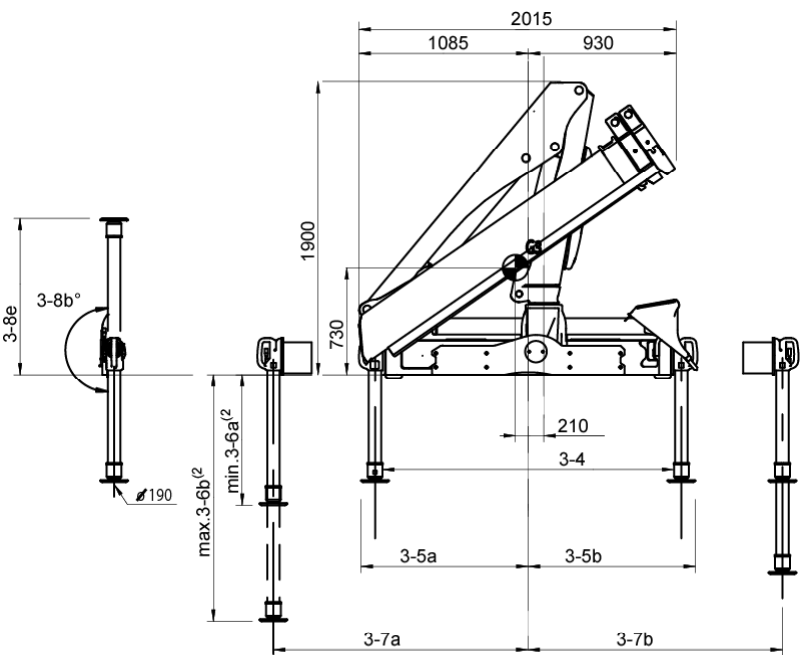

NOTE For specific values, see Table of Measurements

Top View Crane Base

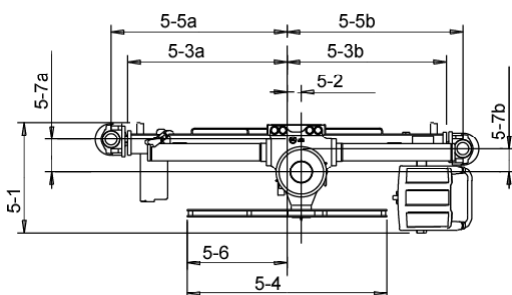

NOTE For specific values, see Table of Measurements

Chassis Installation

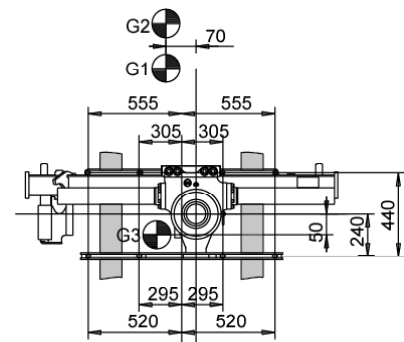

(1) Variable value depending on option.
 (2) Variations may occur depending on mounting position.

Load Diagram

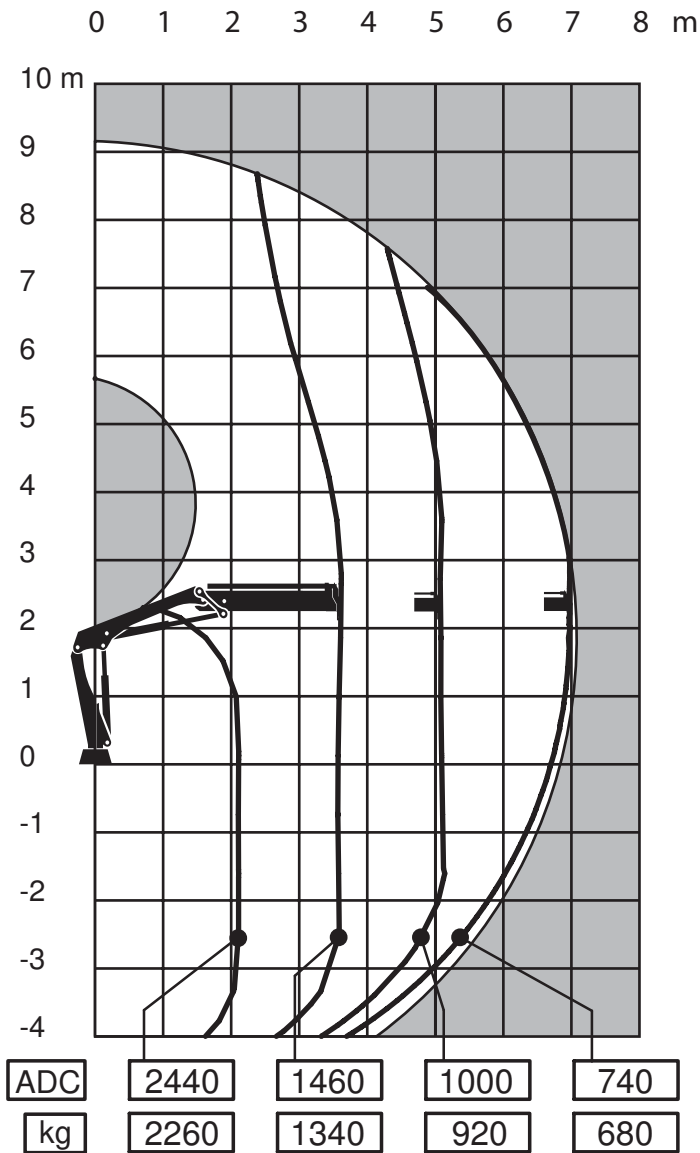

Side View Unfolded Close in Area

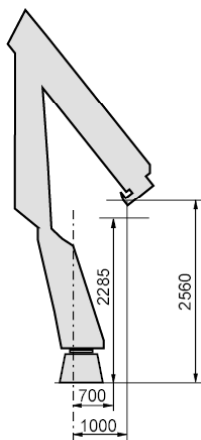

Capacity and performance

Lifting capacity with ADC	52	(kNm)
Lifting capacity	47	(kNm)
Standard lifting capacity at standard outreach with ADC	2.1	(m) - 2440 (kg)
	3.6	(m) - 1460 (kg)
	5.1	(m) - 1000 (kg)
	6.9	(m) - 740 (kg)
Standard lifting capacity at standard outreach	2.1	(m) - 2260 (kg)
	3.6	(m) - 1340 (kg)
	5.1	(m) - 920 (kg)
	6.9	(m) - 680 (kg)
Manual lifting capacity at extension	9.0	(m) - 520 (kg)
	11.0	(m) - 350 (kg)
Hydraulic boom extension	3.5	(m)
Lifting height above installation level hydraulic	9.2	(m)
Slewing torque	7.7	(kNm)
V80 Slewing speed	15	(°/s)
Slewing angle	410	(°)
Lifting speed	1.3	(m/s)

Functional demands

Recommended oilflow low	30	(l/min)
Recommended oilflow high	40	(l/min)
Working pressure	26	(MPa)
Max slope viable at full capacity	5	(°)
Oil in tank	65	(l)
Tank capacity	75	(l)

Weights and measurements

Height in folded position	1900	(mm)
Width in folded position	2015	(mm)
Installation space needed	650	(mm)
Weight of crane	810	(kg)
Weight control stations (platform & top seat)	30	(kg)
Weight hose- and pipe kit	35	(kg)

Side View Unfolded Stretched

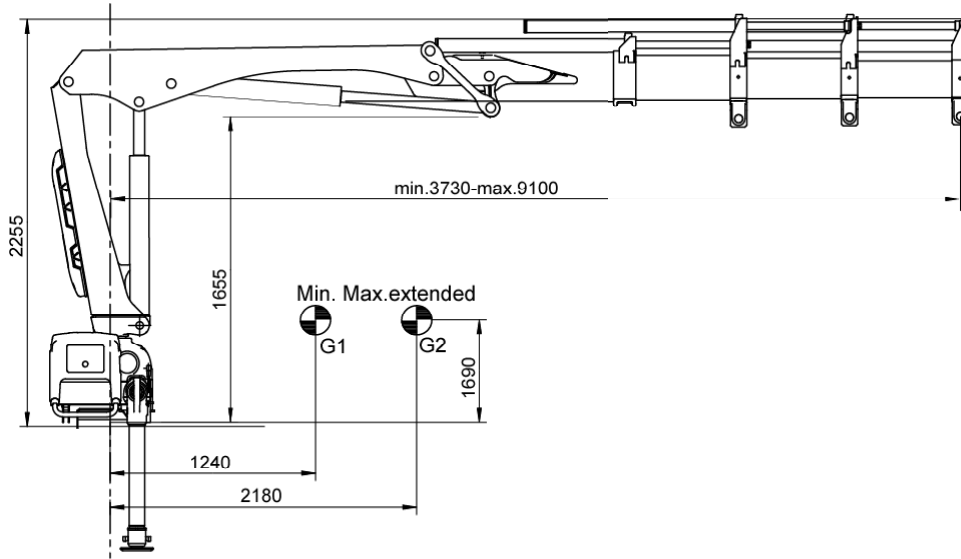

Side View Folded



Front View Folded

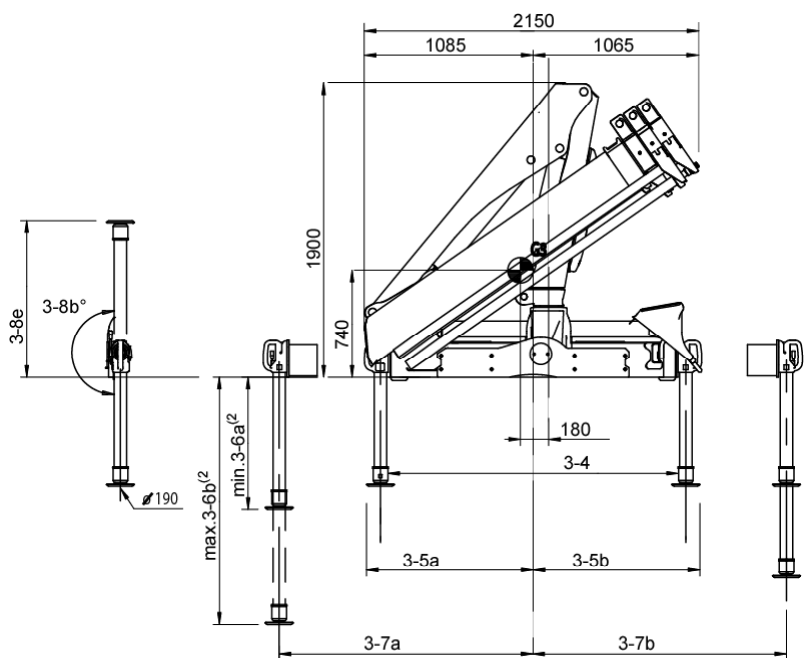

NOTE For specific values, see Table of Measurements

Top View Crane Base

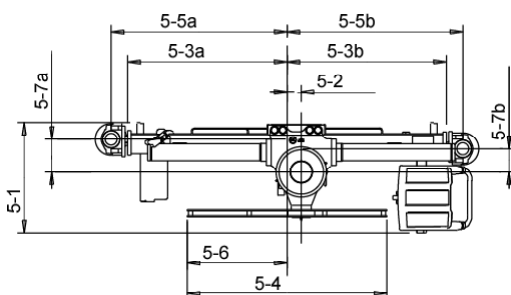

NOTE For specific values, see Table of Measurements

Chassis Installation

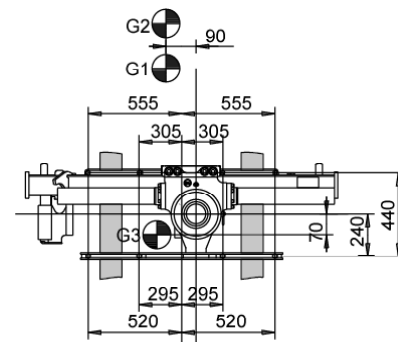

(1) Variable value depending on option.
 (2) Variations may occur depending on mounting position.

Load Diagram

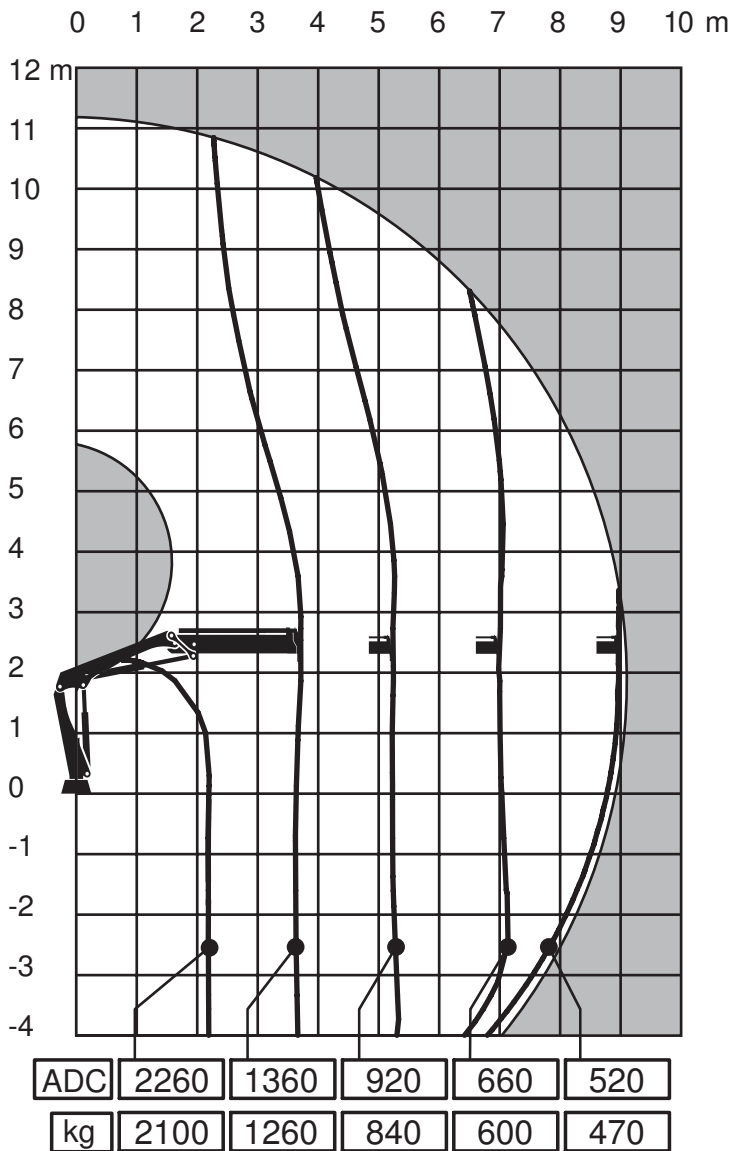

Side View Unfolded Close in Area

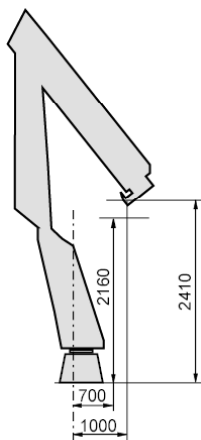

Capacity and performance

Lifting capacity with ADC	49	(kNm)
Lifting capacity	46	(kNm)
Standard lifting capacity at standard outreach with ADC	2.2 (m)	- 2260 (kg)
	3.7 (m)	- 1360 (kg)
	5.3 (m)	- 920 (kg)
	7.1 (m)	- 660 (kg)
	9.0 (m)	- 520 (kg)
Standard lifting capacity at standard outreach	2.2 (m)	- 2100 (kg)
	3.7 (m)	- 1260 (kg)
	5.3 (m)	- 840 (kg)
	7.1 (m)	- 600 (kg)
Manual lifting capacity at extension	7.1 (m)	- 470 (kg)
	9.0 (m)	- 360 (kg)
Hydraulic boom extension	5.4	(m)
Lifting height above installation level hydraulic	11.2	(m)
Slewing torque	7.7	(kNm)
V80 Slewing speed	15	(°/s)
Slewing angle	410	(°)
Lifting speed	1.7	(m/s)

Functional demands

Recommended oilflow low	30	(l/min)
Recommended oilflow high	40	(l/min)
Working pressure	26	(MPa)
Max slope viable at full capacity	5	(°)
Oil in tank	65	(l)
Tank capacity	75	(l)

Weights and measurements

Height in folded position	1900	(mm)
Width in folded position	2150	(mm)
Installation space needed	650	(mm)
Weight of crane	880	(kg)
Weight control stations (platform & top seat)	30	(kg)

Side View Unfolded Stretched

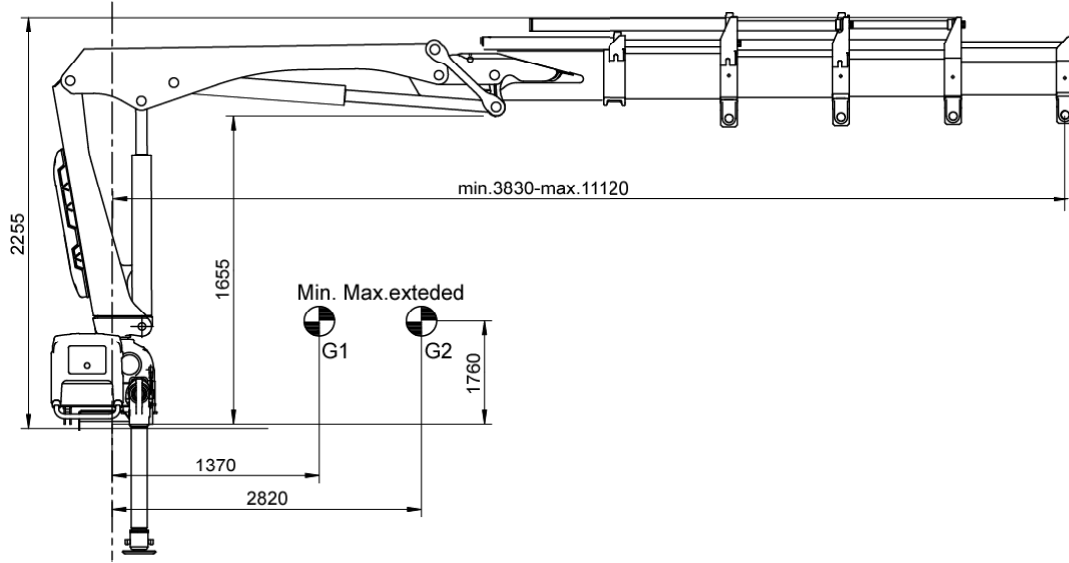

Side View Folded



Front View Folded

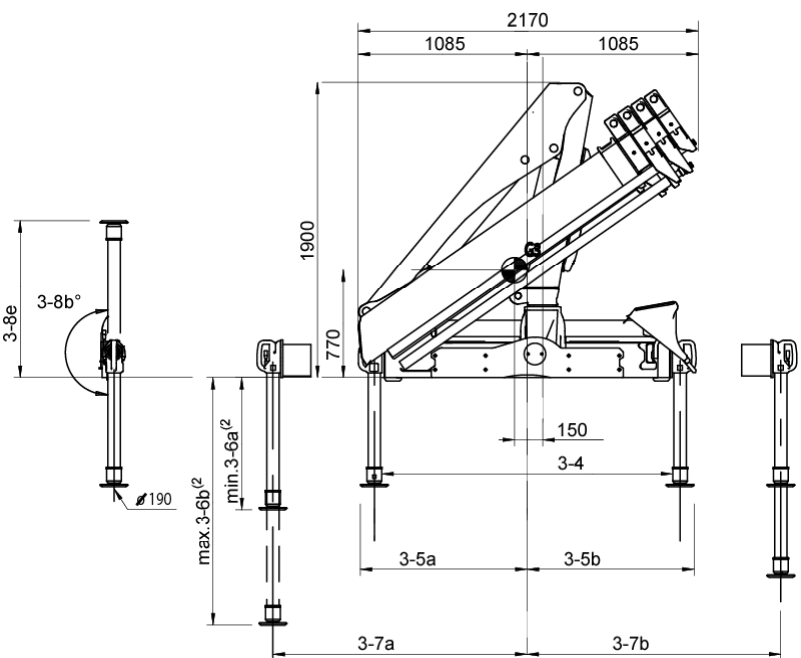

NOTE For specific values, see Table of Measurements

Top View Crane Base

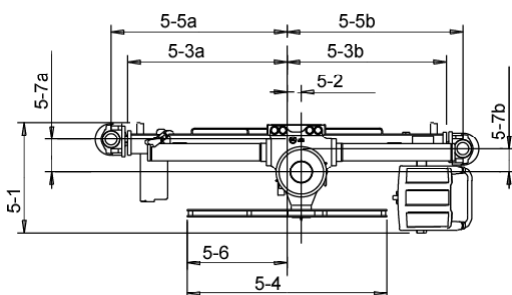

NOTE For specific values, see Table of Measurements

Chassis Installation

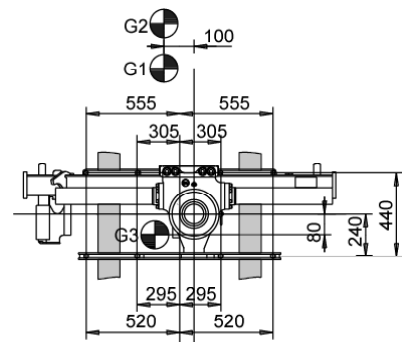

(1) Variable value depending on option.
 (2) Variations may occur depending on mounting position.

Load Diagram

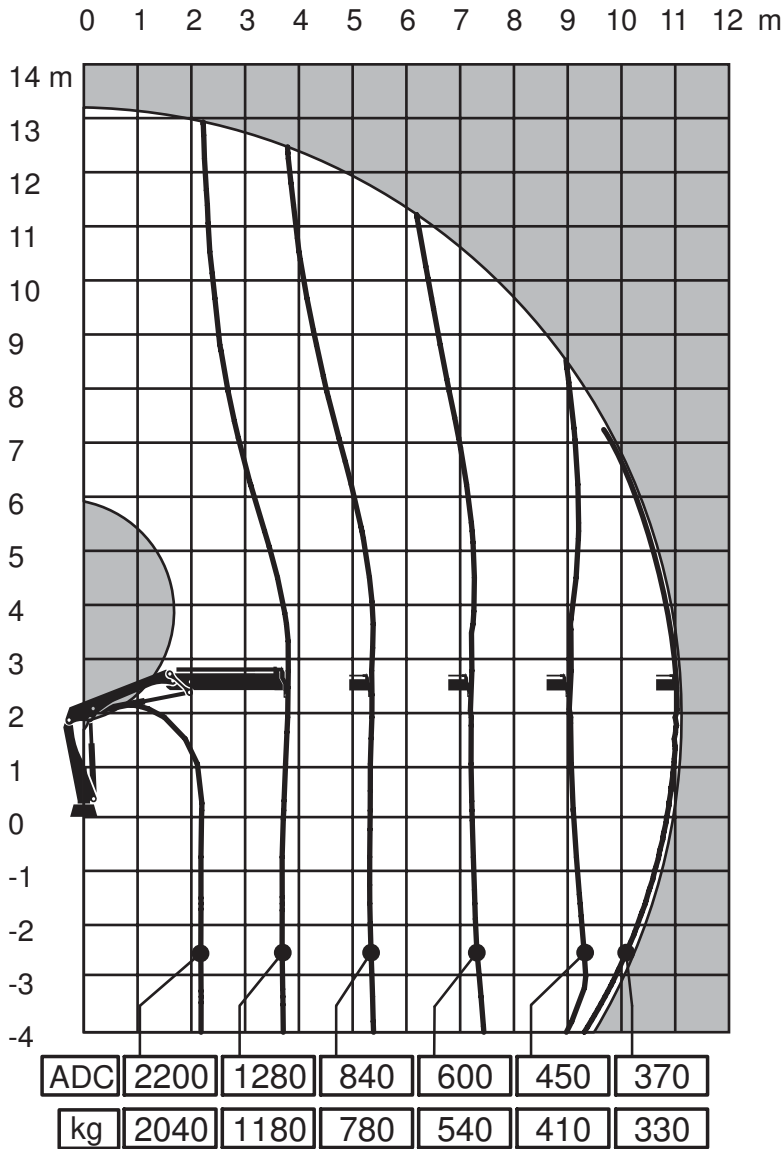

Side View Unfolded Close in Area

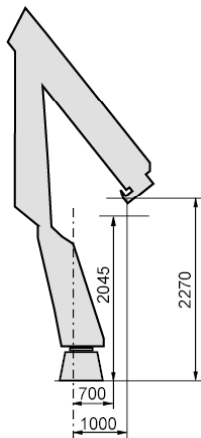

Capacity and performance

Lifting capacity with ADC	48	(kNm)
Lifting capacity	44	(kNm)
Standard lifting capacity at standard outreach with ADC	2.2 (m)	- 2200 (kg)
	3.8 (m)	- 1280 (kg)
	5.4 (m)	- 840 (kg)
	7.2 (m)	- 600 (kg)
	9.1 (m)	- 450 (kg)
Standard lifting capacity at standard outreach	11.0 (m)	- 370 (kg)
	2.2 (m)	- 2040 (kg)
	3.8 (m)	- 1180 (kg)
	5.4 (m)	- 780 (kg)
	7.2 (m)	- 540 (kg)
Hydraulic boom extension	9.1 (m)	- 410 (kg)
	11.0 (m)	- 330 (kg)
Hydraulic boom extension	7.3	(m)
Lifting height above installation level hydraulic	13.2	(m)
Slewing torque	7.7	(kNm)
V80 Slewing speed	15	(°/s)
Slewing angle	410	(°)
Lifting speed	2.0	(m/s)

Functional demands

Recommended oilflow low	30	(l/min)
Recommended oilflow high	40	(l/min)
Working pressure	26	(MPa)
Max slope viable at full capacity	5	(°)
Oil in tank	65	(l)
Tank capacity	75	(l)

Weights and measurements

Height in folded position	1900	(mm)
Width in folded position	2170	(mm)
Installation space needed	650	(mm)
Weight of crane	940	(kg)
Weight control stations (platform & top seat)	30	(kg)

General Technical Data

Height Stretched Diagram

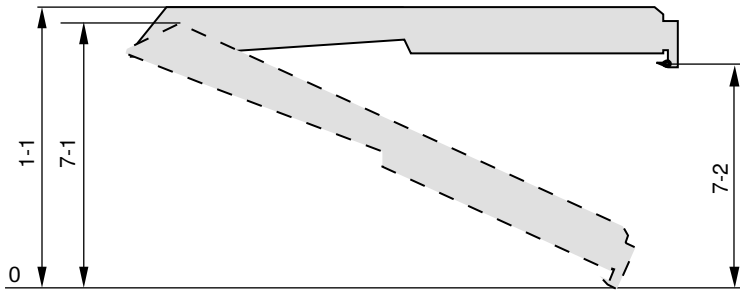

Crane	1-1 (mm)	7-1 (mm)	7-2 (mm)
HIAB XS 055 B-1	2310	1955	1835
HIAB XS 055 B-2	2320	1955	1850
HIAB XS 055 BS-1	2310	1955	1835
HIAB XS 055 BS-2	2320	1955	1850
HIAB XS 055 D-1	2135	1970	1660
HIAB XS 055 D-2	2145	1970	1675
HIAB XS 055 D-3	2255	1975	1790
HIAB XS 055 D-4	2255	1975	1770
HIAB XS 055 DS-1	2135	1965	1660
HIAB XS 055 DS-2	2145	1965	1675
HIAB XS 055 DS-3	2255	1970	1790
HIAB XS 055 DS-4	2255	1970	1770

Rotation Diagram

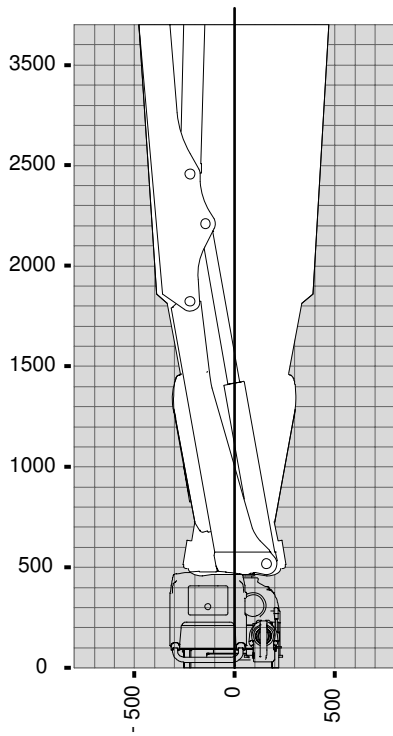

Crane with Link System B

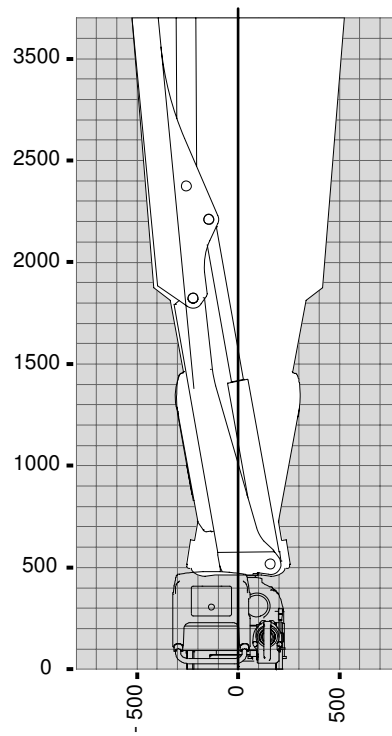

Crane with Link System D

Table of Measurements

To find a configuration of stabilizer legs that match your application first choose a configuration of your choice in **Stabilizer Configuration**. Second, find the measurements in **Dimensions & Measurements**.

Stabilizer Configuration

		Configuration					
		1	2	3	4	5	6
Stabilizer extension	Short	•	•	•			
	Medium				•	•	•
Stabilizer leg	Short	•			•		
	Medium		•			•	
	Long			•			•

Dimensions & Measurements

Front View Folded

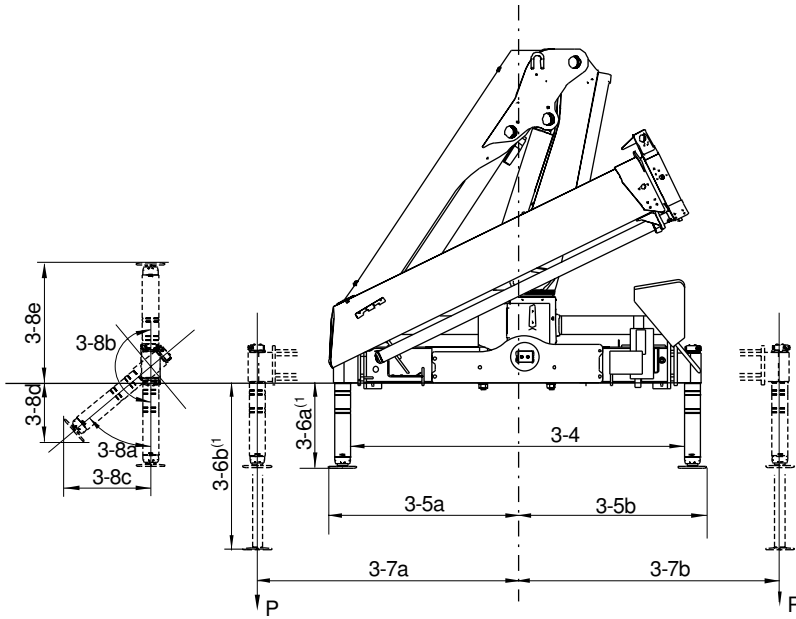

Top View Crane Base

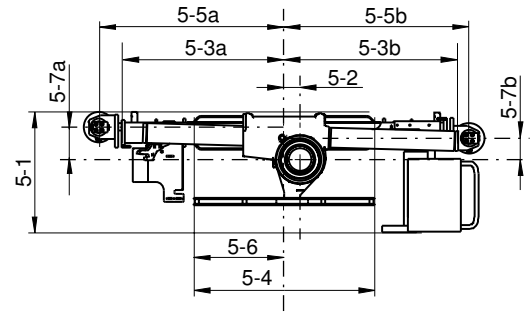

Configuration

Dimensions & Measurements

		1	2	3	4	5	6
3-4	mm	1880	1880	1880	1880	1880	1880
3-5a	mm	1085	1085	1085	1085	1085	1085
3-5b	mm	1085	1085	1085	1085	1085	1085
3-6a ⁽¹⁾	mm	545	695	850	545	695	850
3-6b ⁽¹⁾	mm	990	1290	1600	990	1290	1600
3-7a	mm	1630	1630	1630	2375	2375	2375
3-7b	mm	1630	1630	1630	2375	2375	2375
3-8a	deg						
3-8b	deg	180	180	180	180	180	180
3-8c	mm						
3-8d	mm						
3-8e	mm	870	1020	1175	870	1020	1175
5-1	mm	630	630	630	630	630	630
5-2	mm	100	100	100	100	100	100
5-3a	mm	915	915	915	915	915	915
5-3b	mm	915	915	915	915	915	915
5-4	mm	1140	1140	1140	1140	1140	1140
5-5a	mm	985	985	985	985	985	985
5-5b	mm	985	985	985	985	985	985
5-6	mm	570	570	570	570	570	570
5-7a	mm	145	145	145	145	145	145
5-7b	mm	145	145	145	145	145	145
P	kN						
Weight	kg	105	110	120	140	150	160

NOTES

A series of horizontal dotted lines for taking notes.

NOTES

A series of horizontal dotted lines for taking notes, spanning the width of the page.



Hiab is part of Cargotec Corporation

